

Proceedings of Knowledge Management International Conference (KMICe) 2016

Editors:

Assoc. Prof. Dr. Fauziah Baharom

Assoc. Prof. Dr. Yuhanis Yusof

Assoc. Prof. Dr. Haslina Mohd

Mr. Nurnasran Puteh

Copyright © 2016 UUM College of Arts and Sciences.

Published biannually by School of Computing, College of Arts and Sciences, Universiti Utara Malaysia.

ISBN 978-967-0910-19-2



eISBN 978-967-0910-20-8



All Rights reserved. No part of this publication may be reproduced in any form or by any means without prior permission from the copyright holder.

Printed in Malaysia.

This proceeding is also published in electronic format
KMICe website <http://www.kmice.cms.net.my>

KMICe2016 WORKING COMMITTEE

ADVISOR

Professor Dato' Seri Dr. Mohamed Mustafa Ishak (Vice-Chancellor of Universiti Utara Malaysia)
Dr. Arthit Ourairat (Rangsit University, Thailand)

CONFERENCE CHAIR

Prof. Dr. Norshuhada Shiratuddin

VICE CHAIRPERSON

Assoc. Prof. Dr. Haslina Mohd

TREASURER

Ms. Aniza Mohamad Din

PROMOTION & PUBLICITY

Dr. Mohd Shamrie Sainin

Dr. Azizi Ab Aziz

Dr. Rohaida Romli

Mrs. Musyrifah Mahmud

FINANCE & SPONSORSHIP

Prof. Dr. Norshuhada Shiratuddin

Assoc. Prof. Dr. Fauziah Baharom

Dr. Mohd Shamrie Sainin

Mr. Mohd Samsu Sajat

ACCOMMODATION

Mrs. Noraziah Che Pa

Dr. Nor Laily Hashim

LOCAL ARRANGEMENT

Prof. Dr. Rusli Bin Hj Abdullah (UPM)

Prof. Dr. Norita Md Norwawi (USIM)

Prof. Madya Dr. Azizah Bte Suliman (UNITEN)

Dr Dayang Nur Fatimah binti Awang Iskandar (UNIMAS)

Dr. Mohammad Nazir Ahmad (UTM)

Dr. Manmeet Mahinderjit Singh (USM)

Dr Shuzlina Abdul Rahman (UiTM - Shah Alam)

Dr Suraya Binti Hamid (UM)

Dr. Nik Zulkarnaen Bin Khidzir (UMK)

Mrs. Dayang Hanani binti Abang Ibrahim (UNIMAS)

Mrs. Rusnida Romli (UNIMAP)

Mrs. Siti Rafidah Muhamat Dawam (UiTM)

Mr. Mohd Helmy Bin Abd Wahab (UTHM)

Natalya Rudina Shamsuar (MMU)

Mohd Nizam B Osman (UiTM - Perlis)

Dr. Hibo Bosim Alwon Al-Duloimi (Al-Mansour University College, Iraq)

Assoc. Prof Dr. Ismail Rakip Karas (Karabuk University, Turkey)

SECRETARY

Dr. Rahayu Ahmad

SECRETARIAT

Dr. Sobihatun Nur Ab Salam

Dr. Siti Mahfuzah Sarif

Mrs. Rozita Saad

LOGISTICS & TRANSPORTATION

Mr. Mohd Samsu Sajat

Mr. Suwannit Chareen

Srisawad Yongyut (RU, Thailand)

Pinthong Kongka (RU, Thailand)

Thanadetch Thanaakaradetch (RU,
Thailand)

KMICe2016 TECHNICAL COMMITTEE

Publishing Chair: Assoc. Prof. Dr. Fauziah Baharom
Proceeding Committee: Assoc. Prof. Dr. Yuhanis Yusof
Mr. Nurnasran Puteh
Prof. Dr. Shahizan Hassan
Dr. Massudi Mahmuddin

Board of Reviewers:

INTERNATIONAL

Prof. Dr. Binod Kumar, <i>India</i>	Assist. Prof. Dr. Todsanai Chumwatana, <i>Thailand</i>
Prof. Dr. M. Aruna, <i>India</i>	Assist. Prof. Dr. M.L. Kulthon Kasemsan, <i>Thailand</i>
Prof. Dr. Ali Yazici, <i>Turkey</i>	Assist. Prof. Dr. Chetneti Srisa-An, <i>Thailand</i>
Prof. Dr. Kiran Sree Pokkuluri, <i>India</i>	Dr. Agung Sedyono, <i>Indonesia</i>
Prof. Alina Badulescu, <i>Romania</i>	Dr. Florin Molnar-Matei, <i>Romania</i>
Prof. Calin Ciufudean, <i>Romania</i>	Dr. Hiba Basim Alwan Hussain Al-Dulaimi, <i>Iraq</i>
Prof. Erwin B. Daculan, <i>Philippines</i>	Dr. Nordin Abu Bakar, <i>Japan</i>
Prof. Sanjit Setua, <i>India</i>	Dr. Somboon Anekritmongkol, <i>Thailand</i>
Prof. Witold Chmielarz, <i>Poland</i>	Assist. Prof. Mohd. Maroof Siddiqui, <i>India</i>
Assoc. Prof. Anna Iwona Adamik, <i>Poland</i>	Mr. Sitali Wamundila, <i>Zambia</i>
Assoc. Prof. Robert Ulewicz, <i>Poland</i>	Ms. Ichayaporn Chuaychoo, <i>Thailand</i>
Assoc. Prof. Andreea Zamfir, <i>Romania</i>	
Assoc. Prof. Petr Hajek, <i>Czech Republic</i>	

NATIONAL

Dato Prof. Dr. Mohd Idrus Hj Mohd Masirin	Dr. Maslinda Mohd Nadzir
Prof. Dr. Hishamuddin Md Som	Dr. Massudi Mahmuddin
Prof. Dr. Shahizan Hassan	Dr. Mazida Ahmad
Prof. Dr. Norshuhada Shiratuddin	Dr. Mazura Mat Din
Prof. Dr. Tong-Ming Lim	Dr. Mohammad Bin Hossin
Assoc. Prof. Dr. Abdelnaser Omran Ali	Dr. Mohamad Farhan Mohamad Mohsin
Assoc. Prof. Dr. Azman Yasin	Dr. Mohd Farhan Md Fudzee
Assoc. Prof. Dr. Ibtisam Abdul Wahab	Dr. Mohd. Hasbullah Omar
Assoc. Prof. Dr. Ruzaini Bin Abdullah Arshah	Dr. Mohd Heikal Husin
Assoc. Prof. Dr. Siti Norezam Othman	Dr. Mohd Razilan Abdul Kadir
Assoc. Prof. Dr. Yip Mum Wai	Dr. Mohd Zalisham Jali
Assist. Prof. Dr. Hen Kai Wah	Dr. Muhamad Mat Noo
Assoc. Prof. Dr. Shafiz Affendi Mohd Yusof	Dr. Mustafa Muwafak Alobaedy
Dr. Adam Mohd Saifudin	Dr. Nazeri Mohammad
Dr. Azizi Bin Ab Aziz	Dr. Ng Keng Hoong
Dr. Azman Taa	Dr. Noorihan Abdul Rahman
Dr. Azrul Hazri Jantan	Dr. Norashikin Ali
Dr. Christine Nya-Ling Tan	Dr. Nor Hazlyna Binti Harun
Dr. Faizuniah Pangil	Dr. Nor Intan Saniah Sulaiman
Dr. Hamirul `Aini Bt. Hambali	Dr. Nor Laily Hashim
Dr. Hazaruddin Bin Harun	Dr. Norizan Mohd Yasin
Dr. Iskandar bin Ishak	Dr. Nurul Azma Zakaria
Dr. Ishola Dada Muraina	Dr. Rahayu Ahmad
Dr. Ismi Rajiani	Dr. Rohaida Romli
Dr. Jashpal Kaur Bhatt	Dr. Sami Mohamed Saleh Al Haderi
Dr. Kasturi Dewi Varathan	Dr. Shahrinaz Ismail
	Dr. Shahrul Azmi Mohd Yusof
	Dr. Siti Mahfuzah Sarif

Dr. Siti Nurul Mahfuzah Mohamad
Dr. Sukumar Letchmunan
Dr. Sulfeeza Mohd Drus
Dr. Tan Fee Yean
Dr. Tan Tse Guan
Dr. Zarul Fitri Zaaba
Mr. Azlan Osman
Mr. Feras Zen Alden
Mr. Kuek Thiam Yong
Mr. Mohd Helmy Abd Wahab
Mr. Mohd Ibrahim Hai
Mr. Mohd Rushdi Idrus
Mr. Mohd Suffian Sulaiman
Mr. Sanath Sukumaran
Mr. Syahrul Nizam Junaini
Mr. Yousef Fazea
Mr. Zul Hasrizal Bin Bohari

Mrs. Ammuthavali a/p Ramasamy
Mrs. Juhaida Abu Bakar
Mrs. Lailatul Faizah Abu Hassan
Mrs. Maziani Sabudin
Mrs. Musyrifah Mahmud
Mrs. Norfadzilah Abd Razak
Mrs. Norkhairani Abdul Rawi
Mrs. Nurfaeza Jali
Mrs. Rafidah Abd Razak
Mrs. Yana Mazwin Mohmad Hassim
Ms. Aniza Mohamed Din
Ms. Ina Suryani
Ms. Noraziah Chepa
Ms. Sharmila Mat Yusof
Ms. Shatina Saad
Ms. Yau'mee Hayati Hj Mohamed Yusof

KEYNOTE SPEAKER

“From Big Data to Knowledge Discovery: A Difficult Journey”

Mr. Scott M. Leeb

Engagement Director, IKnow LLC, Virginia USA

**“Knowledge Management System as a Tool for
Managing Knowledge of Big Data in a Collaborative Environment”**

Prof. Dr. Rusli Abdullah

Universiti Putra Malaysia, Malaysia

Table of Content

ID	Title	Page
PID4	An Ontology Knowledge Management for a User Preference of E-Learning System Chetneti Srisa-an and Nida Denphaisarn, THAILAND	1
PID6	An Experiment on the Performance of Shortest Path Algorithm Simon Chan Yew Meng, Nur'ayuni Adnan, Syazwan Syafiqah Sukri and Wan Mohd Nazmee Wan Zainon, MALAYSIA	7
PID9	Improving Employees Retention Rate Through Knowledge Management and Business Intelligence Components Herison Surbakti and Azman Ta'a, INDONESIA	13
PID17	GPU-based Odd and Even Hybrid String Matching Algorithm Ghazal Rahbari, Nur'Aini Abdul Rashid and Wahidah Husain, MALAYSIA	18
PID18	Knowledge Sharing Factors Among EIS Students In a Private University Chuleekorn Nuansomsri and Suttisak Jantavongso, THAILAND	25
PID20	Decision Making in Local Government: The Myth of Success Model of Information System Mohd Zool Hilmie Mohamed Sawal and Kamarudin Ngah, MALAYSIA	31
PID22	Retaining Knowledge Worker through Motivation Hway-Boon Ong, Lee-Lee Chong and Kasuma Nurhazwani Mohd Hatta, MALAYSIA	35
PID25	A Study on Transforming the Knowledge in Design Learning Environment Nur Aziemah Mohamad, Khairul Anwar Mohamed Khaidzir, and Roliana Ibrahim, MALAYSIA	38
PID26	The Impact of Collection and Dissemination of Information towards Public Complaint on Municipal Services Zaherawati Zakaria, Kamarudin Ngah, Nazni Noordin and Mohd Zool Hilmie Mohamed Sawal, MALAYSIA	44
PID27	The Formulation of New Model of Decision-Making Process in Malaysian Local Government Kamarudin Ngah, Ravindra Nath Vyas, Mohd Fitri Abdul Rahman and Zaherawati Zakaria, MALAYSIA	49
PID29	Amateur Radio Communication Technology Evolution and Issues in Malaysia Azlee Johar, Wan Rozaini Sheik Osman and Azizi Ab. Aziz, MALAYSIA	54
PID30	A Framework for Correcting Human Motion Alignment for Traditional Dance Training Using Augmented Reality Javid Iqbal and Manjit Singh Sidhu, MALAYSIA	59
PID31	Using Hybrid Technique: the Integration of Data Analytics and Queuing Theory for Average Service Time Estimation at Immigration Service, Suvarnabhumi Airport Todsanai Chumwatana and Ichayaporn Chuaychoo, THAILAND	64
PID32	Blended Learning as a Conduit for Inquiry-based Instruction, Active Learning, Formative Assessment and its Impact on Students' Learning Outcomes in Higher Education Chan Yuen Fook, Suthagar Narasuman, Siti Fairuz Dalim, Gurnam Kaur Sidhu and Lee Lai Fong, MALAYSIA	69
PID36	Determination of Corporate Governance Disclosure Chrisna Suhendi and Maya Indriastuti, MALAYSIA	74

PID37	Financial Ratios: Prediction of Changes in Profit Future on Islamic Banks Maya Indriastuti and Luluk Muhimatul Ifada, INDONESIA	78
PID38	Cognitive Dissonance of Online Socialization among Tertiary Students Aiza Johari, Adib Sarkawi, Awang Rozaimie Awang Shuib, Azlina Bujang and Zainon Haji Bibi, MALAYSIA	81
PID39	Developing Knowledge Asset Valuation Model using Knowledge Experts Wong Man Wai, Ammuthavali Ramasamy and Marini bt Othman, MALAYSIA	87
PID43	The Factors Affecting Knowledge Sharing Behaviour within a Case Study Taiwanese Small Business Hsing H. Lee, TAIWAN	93
PID44	The Effect of Macro Economy and Characteristics of Company on Beta Syariah Shares Lisa Kartikasari, INDONESIA	99
PID45	iHOME: An Ambient Intelligence Mobile CrowdSensing Smart Home System Lim Poon Koon and Manmeet Mahinderjit Singh, MALAYSIA	104
PID46	A Secure Near Field Communication (NFC)-enabled Attendance on Android Mobile for University David Ong Da Wei and Manmeet Mahinderjit Singh, MALAYSIA	110
PID48	Determinants of Collaboration and Innovation in Creative Industries - The Case of the Czech Republic Jan Stejskal, and Petr Hajek, CZECH REPUBLIC	116
PID49	Knowledge Spillover Effects in German Knowledge-Intensive Industries Petr Hájek, and Jan Stejskal, CZECH REPUBLIC	122
PID50	The Optimal LSB Substitution Matrix Technique for Image Hiding Sunchai Suttipong and Somboon Anekritmongkol, THAILAND	128
PID55	Exploring Affective Mediation Digital Training Model for Training of Trainers (ToT) in Education: A Systematic Literature Review Siti Nurhazzalilla Omar, Sobihatun Nur bt Abdul Salam and Fauziah Abdul Rahim, MALAYSIA	134
PID60	Inter-organizational Knowledge Transfer Processes: An Integrative Perspective Sommai Khantong and Mohammad Nazir Ahmad, MALAYSIA	138
PID67	Social Information Retrieval for Online Community Question Answering Services Lee Jun Choi, Cheah Yu-N and Cheah Wai Shiang, MALAYSIA	145
PID68	Linking Community of practices and open innovation through absorptive capacity: A conceptual framework for university-industry collaboration Rabiah Eladwiah Abdul Rahim, Juraifa Jais and Nor'ashikin Ali, MALAYSIA	150
PID69	Opinion Spamming in Social Media: A brief systematic review Khairul Nizam Baharim and Suraya Hamid, MALAYSIA	156
PID71	Student's Perception to Learning of Innovative Skills through Multi-Dimensional Visualization System: Reliability and Validity Tests of some Measurements Ishola Dada Muraina and Huda Haji Ibrahim, MALAYSIA	162
PID72	Knowledge Management in Indonesia Small and Medium Enterprises (SMEs): A Conceptual Model Ardian Adhiatma and Olivia Fachrunnisa, INDONESIA	168

PID73	Knowledge Audit on the Implementation of Knowledge Management in Public Sector Research Institute in Malaysia: A Case Study Harlisa Zulkifli, Mohammad Fikry Abdullah dan Mardhiah Ibrahim, MALAYSIA	173
PID74	Strategy Mining on University Students' Feedback Angela Lee Siew Hoong and Tong-Ming Lim, MALAYSIA	179
PID75	Knowledge Management, Innovative intelligence and Sustainable Competitive Advantage in Small and Medium Entreprises Rohana Ngah, Zarina Salleh and Ismail Ab Wahab, MALAYSIA	186
PID77	Behavioral Intention to use Knowledge Sharing Tools : Positive and Negative Affect on Affective Technology Acceptance Model Angela Lee Siew Hoong and Tong-Ming Lim, MALAYSIA	191
PID79	A KM-driven Formative Assessment Framework to Problem-Solving for Law Academics Teaching First Year Non-Law Students Kanchana Chandran, Sanath Sukumaran and Kalpana Chandran, MALAYSIA	197
PID81	Comparative Study of Apriori-variant Algorithms Sofianita Mutalib, Ammar Azri Abdul Subar, Shuzlina Abdul-Rahman and Azlinah Mohamed, MALAYSIA	203
PID82	Benchmarking Process of Knowledge Management Best Practice Model for Higher Learning Institution Halijah Ismail, Rusli Abdullah and Yusmadi Yah Jusoh, MALAYSIA	209
PID83	Knowledge Sharing Behaviour in Libraries: A Case Study of Raja Tun Uda Library, Selangor, Malaysia Azman Mat Isa, Nurul Farhana Mohd Jemal and Nordiana Mohd Nordin, MALAYSIA	217
PID87	Domain of Application in Context-Aware Recommender Systems: A Review Maizatul Akmar Ismail, Khalid Haruna and Shuhaida Mohamed Shuhidan, MALAYSIA	223
PID88	System Requirement Specifications for A Semantic Knowledge Management System for Collaborative Learning Environment Zaihisma Che Cob, Rusli Abdullah, Sulfeeza Mohd. Drus and Nor'ashikin Ali, MALAYSIA	229
PID90	Assessing Academics' Knowledge Sharing Intention in Institutions of Higher Learning Christine Nya-Ling Tan, Muhammad Ashraf Fauzi and Ramayah Thurasamy, MALAYSIA	235
PID92	Stock Split Analysis on Price and Trading Volume in Indonesian Stock Exchange Ibnu Khajar, INDONESIA	241
PID97	An Improved Searching Method for Retrieving Local Knowledge Information Wong Poh Lee, Mohd Azam Osman, Tarmiji Masron and Abdullah Zawawi Talib, MALAYSIA	247
PID98	Knowledge Management Systems Success Model: A Partial Least Square Approach Norashikin Ali, Zaihisma Che Cob and Hidayah Sulaiman, MALAYSIA	252
PID99	Social Identity, Collective Engagement and Communal Patent for Successful Digital Collaboration Olivia Fachrunnisa, Ardian Adhiatma and Mustafa, INDONESIA	258
PID101	Observed Demographic Differentials in User Perceived Satisfaction on the Usability of Mobile Banking Applications Emmanuel O.C. Mkpojiogu, Nor Laily Hashim and Rabiu Adamu, MALAYSIA	263
PID104	Knowledge Utilization and Decision Making in Construction Projects in Malaysia Ali Mohammed Alashwal and Ng Wen Si, MALAYSIA	269

PID106	Critical Factors in Developing Knowledge Management Systems Sanath Sukumaran, S.M.F.D. Syed Mustapha and Kanchana Chandran, MALAYSIA	275
PID112	Malaycious: Usable Mobile Food Finding Application Lee Pui Yen and Zarul Fitri Zaaba, MALAYSIA	284
PID113	Empowering the Youth Through Online Social Enterprise Income Generation: A Study in Malaysia and USA Noormaizatul Akmar Ishak, Muhamad Zulkiflee Osman, Syed Zulkarnain Syed Idrus, Wan Nor Ashiqin Wan Ali, Azizan Bahari and Nur Azila Azahari, MALAYSIA	291
PID114	Skills and Competitiveness for Poverty Reduction in Northeast, Thailand by Enhancing Knowledge Management in Capacity Building Framework Thossaporn Thossansin, THAILAND	297
PID115	A Proposed Framework for Mobile Internet QoS Customer Satisfaction using Big Data Analytics Techniques Ayisat W. Yusuf-Asaju , Zulkhairi Md Dahalin and Azman Ta'a, MALAYSIA	303
PID117	Complaint Management in Public Services: A Case Study at Local District Municipal Authority in Malaysia Shatina Saad and Muhammad Halim Nizarwan, MALAYSIA	311
PID118	The Relationship and Influence of Leadership Style Towards Knowledge Management Activities Ahmad Sufi Alawi Idris, Adnan Jamaludin, Abd. Latif Abdul Rahman and Ayuffeirah Mislan. MALAYSIA	317
PID119	Identifying Game Design Factor for The Development of Educational Digital Games Sumet Pongphankae and Jittrapol Intarasirisawat, THAILAND	323
PID121	Knowledge Management Initiatives In Contact Centre: A Case Study In Tenaga Nasional Berhad Siti Rafidah Mukiar, Nor'ashikin Ali and Rabiah Eladwiah Abdul Rahim, MALAYSIA	327
PID122	A Study on the Effects of Window Size on Electrocardiogram Signal Quality Classification Tanatorn Tanantong, THAILAND	333
PID125	Antecedents Cloud ERP Adoption in Manufacturing Industry: Nigerian SMES Context Usman Musa Zakari Usman, Mohammad Nazir Ahmad and Nor Hidayati Zakaria, MALAYSIA	339
PID126	Moderating Effect of Personal Characteristics on Telecentre Adoption for Value Creation Zulkhairi Md Dahalin, Nor Iadah Yusop and Zahurin Mat Aji, MALAYSIA	345
PID130	Multi perspective Analysis the WiFi Performance and Evaluation : Case Study Songkhla Rajabhat University Sasalak Tongkaw and Aumnat Tongkaw, THAILAND	351
PID133	Social Media Literacy and Awareness of the Youth in Secondary school in Southern Thailand Korawan Suebsom and Nopparat Meeplat, THAILAND	356
PID134	Thai Word Segmentation on Social Networks with Time Sensitivity Chirawan Ronran, Sayan Unankard, Wanvimol Nadee, Nongkran Khomwichai and Rangsit Sirirangsi, THAILAND	362
PID135	Using Graph Algorithm and Classification Technique for Finding an Optimal Bus Route in Time-Dependent Travel Times Satjayod Deelertmongkolchai, Todsanai Chumwatana and Choonhapon Thaiupathump, THAILAND	368
PID136	Filtering Spam Mail in Non-Segmented Languages Using Hybrid Approach: the Integration of Stopword Removal, N-gram Extraction and Classification Techniques	373

Ployphailin Khumsong, Todsanai Chumwatana and Supanit Augsirikul, THAILAND

PID143	Goal-UML Approach for Modeling Data Warehouse Requirements of Malaysian Rural Healthcare	379
	Sajaratul Huda Shafie, Azizah Ahmad, and Azman Ta'a, MALAYSIA	
PID154	Does Difference in Secondary and Tertiary Literacy Influence Life Insurance Consumption in the selected ASEAN countries?	385
	Lee Hui Shan, Kevin Low Lock Teng, Chong Shyue Chuan, Sia Bik Kai, MALAYSIA	
PID155	Lexicon-Based and Immune System Based Learning Methods in Twitter Sentiment Analysis	392
	Hamidah Jantan, Fatimatul Zahrah Drahman, Nazirah Alhadi and Fatimah Mamat, MALAYSIA	
PID156	A Comparative Study of Service-Oriented Architecture Maturity Model	399
	Mohd Hamdi Irwan Hamzah, Fauziah Baharom and Haslina Mohd, MALAYSIA	
PID159	Goal Oriented Measurement for Software Sustainable Evaluation Metric Focused on Environmental Dimension	405
	Ruzita Ahmad, Azham Hussain and Fauziah Baharom, MALAYSIA	
PID161	Social Innovation and Strategic Knowledge Management Processes: A critical conceptual overview	411
	Muhamad Nizam Jali, Zakaria Abas, Ahmad Shabudin Ariffin and Nazim Baluch, MALAYSIA	
PID164	Relationship of Knowledge Management Cycle and the Performance from Human, Customer and Organizational Perspective	416
	Rayinda Pramuditya Soesanto, Luciana Andrawina, Indriani Rezki Pratiwi and Amelia Kurniawati, INDONESIA	
PID165	Importance Factors Influencing the Thai Doctors in Rural Area to Use Public Social Media for Work-Related Use: A Case Study of LINE Application	421
	Nattapong Somsakit, Suree Funilkul, and Umaporn Supasitthimethee, THAILAND	
PID166	Critical Analysis in Proposing Persuasive Multimedia Model of Truancy Awareness (PMTA)	427
	Mohamad Lutfi Dolhalit, Sobihatun Nur Abdul Salam, Ariffin Abdul Mutalib and Muhammad Saiful Bahri Yusoff, MALAYSIA	
PID167	A Requirement Model of an Adaptive Emergency Evacuation Center Management	433
	Nor Laily Hashim, Hanif, Azham Hussain, Noraziah Che Pa, Yuhanis Yusof, MALAYSIA	
PID168	The Design and Implementation of Malaysian Indigenous Herbs Knowledge Management System based on Ontology Model	439
	Zulazeze Sahri, Muhd Eizan Shafiq Abd Aziz, Nazirah Ramli and Roger Canda, MALAYSIA	
PID169	Estimating the Right Allocation of Doctors in Emergency Department	446
	Mohd Ridzwan Zulkifli, Muthukkaruppan Annamalai, Kassim Isahak and Rashidi Ahmad, MALAYSIA	
PID170	Design and Evaluation of a Multilanguage Instant Messaging Application	453
	Ahmed Nabeel Ahmed, Suwannit Chareen Chit and Mohd Hasbullah Omar, MALAYSIA	
PID173	iMoS: Intelligence Monitoring System of HIV Carriers in Thailand	459
	Rachasak Somyanonthanakul and Thanachai Ludkrood, THAILAND	
PID174	Pragmatic Design of Methodology in Process-Based Knowledge Integration	463
	Yew Kwang Hooi, Mohd Fadzil B Hassan, Anouar Abrik and Azmi M. Shariff, MALAYSIA	
PID179	Knowledge Integration Improves Flood Disaster Management: A Case Study of Kemaman	470
	Nor Hidayati Zakaria, Mohammad Nazir Ahmad, Mohd Saiful Anuar Mohd Noor and Mazida Ahmad, MALAYSIA	

PID187	Improving Vehicular Ad hoc Networks (VANET) Communication Performance by using Time Gap Folloing Distance (TGFD) Model Suzi Iryanti Fadilah, Mohd Helmy Abd Wahab, Azizul Rahman Mohd Shariff, Khuzairi Md. Zaini, Abdul Samad Sibghatullah, MALAYSIA	475
PID190	Updating Information in Colored QR Code for Knowledge Sharing Azizi Abas, Yuhanis Yusof, and Farzana Kabir, MALAYSIA	480
PID192	The Digital Divide and Behavioral Intention of ICT adoption for Health Information Among People in Rural Communities Nopparat Meeplat and Zulkhairi Md Dahalin, MALAYSIA	486
PID193	Analysis of Contents on Youth Media Participation in Marginalised Communities Norshuhada Shiratuddin and Zainatul Shuhaida Abd Rahman, MALAYSIA	491
PID194	Engaging Youth in Decision-Making Process via New Media: A Case of Rural and Urban Youth in Marginalized Communities in Malaysia Shahizan Hassan, Norshuhada Shiratuddin and Zainatul Shuhaida Abdull Rahman, MALAYSIA	497
PID196	A Review of Three Models for Knowledge Management in Healthcare Zaid A. Sabeeh, SMFD Syed Mustapha and Roshayu Mohamad, MALAYSIA	501
PID197	Fuzzy Distance-based Undersampling Technique for Imbalanced Flood Data Ku Ruhana Ku Mahamud, Maisarah Zorkeflee and Aniza Mohamed Din, MALAYSIA	509
PID198	eBusiness Adoption Studies in Thailand Suttisak Jantavongso, Chuleekorn Nuansomsri, Sumana Kasemsawasdi, Somboon Anekritmongkol, and Saritkan Sitthikraiwoong, THAILAND	514
PID199	A Development of Causal Relationship Model of the Google Sites Usage for Learning at Rangsit University Poungtong Udomsil and Sumaman Pankham, THAILAND	521
PID202	Exploring Competitive Competencies for ICT/Tech Startup Ecosystem Towards The Digital Economy in Thailand: An Empirical Competency Development Investigation Kriengkrai Bhuvanij, M.L.Kulthon Kasemsan and Prasong Praneetpolgrang, THAILAND	526

An Ontology based Knowledge Management for a User Preference of E-Learning System

Chetneti Srisa-an, and Nida Denphaisarn

Rangsit University, Thailand, {chetneti; nida.d}@rsu.ac.th

ABSTRACT

There are many kinds of online electronic courseware services including Google site, Apple's iTunes U, Moodle web-based courseware, and massive open online courses. Knowledge in electronic courseware is widely available but in an unstructured data. Ontology is a good way to manipulate those unstructured data. This paper is aims to understand a user preference in adopting courseware service in an ontology form. An association rule (Data Mining) is applied to find out factors and conditions that lead to decision to choose a service. Due to its benefit to search engine, OWL format is chosen as a file format for this paper. Our experimental results show high percentages of confidence and lift values above 80% and greater than 1 respectively. From the relationship, we construct an ontology for user preference using OWL format. The relationship between ontology knowledge management with user preferences is that knowledge representation represented in Ontology form and then knowledge is organized and acquired via our user preference web-based application.

Keywords: Ontology, user preference, an association rule, data mining, knowledge management.

I INTRODUCTION

In March 2005, the RSU president developed the road map to excellence vision as follows: Competitiveness, E-University, Internationalization, and Certification. All courses are delivered through any high technology device, such as, computer notebook, PDA, smart telephone, the iPhone, the Android-based tablet, and so on. There are many kinds of electronic courseware services in our campus including Google site, Apple's iTunes U, Moodle web-based courseware. Massive open courseware Online (MOOC) is a supplementary by the time this paper published. Table 1 is constructed to compare three services and their available features in 2015. Since MOOC is not in service in our campus yet, it is therefore not in a list of service in Table 1.

All students have rights to consume the knowledge in any kinds of forms. Students can choose any service as a supplementary or main basis on their preference. Each subject can be delivered on many services. One

or more services can be adopted simultaneously. A user preference ontology in this paper stand for a preference of choosing a services. Due to many similar kinds of courseware service, we aims to create a user preference for students to guide them a suitable courses service.

Since 2012, every freshmen student gain an iPad tablet for learning tool in university since 2012; therefore, flipped classroom concept can be easily introduced. According to Flipped classroom concept, Students can study at home and come to discuss in class (Abeysekera & Dawson, 2015). Each teacher has been encouraged by university to create e-learning in flipped classroom forms. Student can view some short video before coming to class to discuss. Thanks to the Center of Innovative Learning (CIL), each instructor who needs help on technology will get a consultancy and be guided. Since each teacher/lecture has a different IT literacy, each one chooses something that he/she eases at it. Beside, many massive open online courses (MOOC) are available for anyone around the world.

Knowledge management is concerned with the representation, organization, acquisition, creation, usage, and evolution of knowledge in its many forms. Each university has produced a huge amount of knowledge information in the form of forms. Most of them are either semi-structured data or unstructured data (Ramana, 2002). They are rarely fit into a relational database. Both students and teachers often only use these documents in their daily life. The objectives of this paper are to propose the methodology to capture, create and represent user preference in an ontology form.

In 2015, students at RSU can access many kinds of services. Statistics show that electronics courseware are widely available; therefore, they are not lack of contents. Moreover, there are a lot of features in each service. Some features do not use by most of users. It is hard for new students to learn all features in each service. They also have to learn many new application and tool for acquiring a same knowledge. Due to an overwhelm services, a user preference ontology will help. Factors and conditions that lead to a decision to choose a service would be identified. We aim to create a user preference for students to guide them suitable courses.

II LITERATURE REVIEW

Abeysekera and Dawson (2015) proposed a flipped classroom approaches that an instructor can assign students to study some electronic courseware to teach them key concepts of a particular topic as part of their homework. In the actual lecture the instructor acts as a facilitator to students who engage in a range of problem-solving activities which require them to apply the knowledge they had acquired through the completion of their homework.

Chandrasekaran et al. (1998) proposed that an ontology based knowledge system is modeled to assist engineers in sharing and maintaining knowledge. An ontology provides a mechanism to formally represent a body of knowledge (Chandrasekaran et al., 1998). Knowledge is in many kinds of forms in an unstructured data. Each university has produced a huge amount of knowledge information in the form of lecture notes, home works, e-mails, news, user groups, chats, web-pages, image-files, video-files, and etc. Most of them are either semi-structured data or unstructured data (Ramana, 2002).

Ontology is a good way to manipulate those unstructured data. In recent approaches, ontologies play an important role for knowledge modeling. Chau (2007) proposed that ontologies are one of the key technologies supporting the Semantic Web and the desire to add meaning to the information available on the World Wide Web. Ontology will improve efficiency in knowledge search. Moreover, ontology also supports knowledge sharing and reuse which is a key process in the knowledge management system (Chau, 2007).

III METHODOLOGY

There are three assumptions in this paper as follows. Firstly, students can choose any service as a supplementary or main basis on their preference. Secondly, modern services such as Google site, Apple's iTunes University, Moodle web-based courseware are in widely available services on student preference. Finally, each subject can be delivered on many kinds of services. One or more same kinds of courseware can be adopted simultaneously. To understand a user preference, the objectives of this paper are to propose a methodology to capture, create and represent ontology for user preference. How to develop ontology for a user preference is a goal of this section. Our methodology consists of five steps.

Step 1: Identify list of features

Table 1 shows a comparison of features. It shows that only a few difference between three services.

Table 1. A comparison of features (2015)

Features	Flipped Class Room service		
	Google Site	iTunes	Moodle LMS
1. Mobile support	✓	✓	✓
2. PERFORMANCE MANAGEMENT AND REPORTING (Dash Board)	N/A	N/A	Plug-in Enable
3. Custom Plugin development	N/A	N/A	✓
4. user friendly interface/ Good Theme and Design	✓	✓	
5. Free for users	✓	✓	✓
6. Email support	✓	✓	✓
7. User Profile	✓	✓	✓
8. User Message Notification	✓	✓	✓
9. Collaborative learning (wiki, blogs, forums, Facebook, youtube)	N/A	N/A	✓
10. Locking and Hiding of activity	✓	✓	✓
11. Platform dependence	No	Yes	No
12. Easy setup and maintenance	✓	✓	
13. Grading	✓	✓	✓
14. User attendance and tracking	✓	✓	✓
15. Announcement	✓	✓	✓
16. Assignment	✓	✓	✓
17. Unit Outline/ Learning Guide/ Course Syllabus	✓	✓	✓
18. Lecture Notes	✓	✓	✓
19. Multimedia used in lectures	✓	✓	✓
20. Multiple announcements throughout the semester	✓	✓	✓
21. Group discussion for collaboration	✓	✓	✓
22. Students encouraged to send a mail message to staff if an enquiry of a personal nature	✓	✓	✓
23. A variety of different types of assignment types	✓	N/A	✓
24. Quizzes for assessment purposes (does not include practice quizzes and those that do not have assessment marks)	✓	N/A	✓
25. Grades were released to students for multiple assessments in the majority of sites	✓	✓	✓
26. Tutorial questions and solutions Model assignments (some at a variety of grading levels) Marking criteria and standards Assessment task templates Practice quizzes Past exam papers and solutions	✓	✓	✓
27. Feedback from students	✓	N/A	✓
28. live discussions	Hangouts On Air	N/A	Plug-in Enable
29. Support local language (Thai)	✓	Partial	✓
30. Register/Class check in	✓	N/A	✓

Table 1 shows that a discrepancy features among three services. There are 10 features that are not available to all three service including feature 2, 3, 9, 11, 23, 24, 27, 28, 29, 30 listed in Table 1. Dashboard and custom plugin (feature #2 in table 1) do not benefit a normal users. Custom Plugin development feature (feature #3 in Table 1) and class attendance checking (feature #30 in Table 1) are not concerned by user. To simplify a model, we can eliminate all same features and show only a discrepancy features. Therefore, factors that influence a normal user can be reduced into only 7 features shown in Table 2.

Table 2. List of features influential to student (2015)

Features	Flipped Class Room service		
	Google Site	iTunes	Moddle LMS
1. Collaborative learning (wiki, blogs, forums, Facebook, Line)	N/A	N/A	✓
2. A variety of different types of assignment types	✓	N/A	✓
3. Feedback from students	✓	N/A	✓
4. Support Thai language	✓	Partial	✓
5. Platform dependence	No	Only ios device	No (HTML 5)
6. Chat or Live Discussion	Hangouts On Air	N/A	Plug-in Enable
7. user friendly interface/ Good Theme and Design	✓	✓	

Step 2: Applying an association rule to identify factors influencing a decision making in choosing service.

The association rule is to help finding association between feature and adoption. By applying the association rule, the questionnaire aims to find the relationship between 7 features (list in Table 2) and courseware enrollment. Since Feature 6 in Table 2 can benefit to instructor/developer, so we eliminate this feature as it depends on developer and instructor. The obtained relationships will be interpreted by the mined rules which are in the forms of antecedence (LHS) and the consequence (RHS) (Nahar et al., 2013).

$$LHS \rightarrow RHS [s,c]$$

$$\text{where } s=\text{support and } c=\text{confident} \quad (1)$$

$$\text{Support} = P(LHS \cap RHS) \quad (2)$$

$$\text{Confident}(LHS \rightarrow RHS) = \frac{P(LHS \cap RHS)}{P(LHS)} \quad (3)$$

$$\text{Lift}(LHS \rightarrow RHS) = \frac{P(LHS \cap RHS)}{P(LHS)P(RHS)} \quad (4)$$

Lift ($x \rightarrow y$) measures whether the occurrence of LHS and that of RHS are independent of each other or not. Lift > 1 implies that there are dependency between LHS and RHS. The higher lift, the more meaningful the interpretation of the relationship of LHS and RHS will be (Nahar, 2013).

Step 3. Analyze data

By applying as association rule, Table 3 and 4 reveal their relationship. We divide the confident values into 2 groups including high confident group (shown in Table 4) and medium/low confident group (shown in Table 3). Table 3 shows that these three features do not concerned by students much comparing to three features in Table 4.

Table 3. Medium/Low confident group

LHS			RHS	Conf	Lift	Sup
1. Collaborative learning (wiki, blogs, forums, Facebook, Line)	2. A variety of different types of assignment types	3. Feedback from students	Will student enroll the course?			
Y			Y	0.77	1.49	21%
	Y		Y	0.75	1.46	32%
		Y	Y	0.72	1.43	18%
Y	Y		Y	0.70	1.40	15%
Y		Y	Y	0.72	1.5	11%
	Y	Y	Y	0.75	1.51	19%
Y	Y	Y	Y	0.79	1.59	12%

From Table 4, Feature 4 (support Thai language) is the most influential to student, and followed by Feature 5 (Platform dependence) and then Feature 7 (user friendly interface). Since every freshly student possess iPad and Apple's ios device is majority OS in the urban area market; therefore, OS platform preference is influential to RSU students.

Table 4. Association rule result

LHS			RHS	Conf	Lift	Sup
4 (Support Thai language)	5 (Platform dependence)	7. user friendly interface/ Good Theme and Design	Enroll course			
Y			Y	0.88	1.75	11%
	Y		Y	0.81	1.61	18%
		Y	Y	0.82	1.64	22%
Y	Y		Y	0.81	1.62	12%
Y		Y	Y	0.80	1.61	22%
	Y	Y	Y	0.81	1.63	13%
Y	Y	Y	Y	0.81	1.62	11%

Factors influencing a decision making in choosing service by Thai students are as follows

1. Preference in supporting Thai language (Partial, Fully Compatible)
2. Preference in OS platform (Apple, Android, Window)
3. Preference in user friendly interface

Step 4: construct an ontology of user preference

Searching results from searched engines can be a long lists of possible answers. Some of them are not relevant to what we are looking for. User preference is added into our system in order to improve a quality of search results. Figure 2 show an overall structure of user preference ontology.

Step 5: Store an ontology into OWL form

A user preference can be varied in each different environment; therefore, it has no certain forms or answers. As shown in Figure 1 and 2, all details cannot store in a regular relational database because of their unstructured data. Ontology form is suitable for an unstructured data. Knowledge management is concerned with the representation, organization, acquisition, creation, usage. In this paper, the relationship between ontology knowledge management with user preferences is that 1. Knowledge representation represent in Ontology form and then 2. Knowledge is organized and acquired via our web application. This file can be used in the knowledge search collaborating with engine in database of information system. It further helps in searching of knowledge from multiple sources such as HTML, documents or databases on the Internet and supports knowledge sharing and knowledge reuse which is the important process in knowledge management. The user preference ontology is stored in the OWL document file as shown in Figure 3. This file can be used in the knowledge search collaborating with engine in database of information system. It further helps in searching of knowledge from multiple sources such as HTML, documents or databases on the Internet and supports knowledge sharing and knowledge reuse which is the important process in knowledge management. The immediate benefit of an ontology based user preference is to search more effectively.

```

<?xml version="1.0" encoding="UTF-8"?>
<rdf:RDF
  xmlns:rdfs="http://www.w3.org/1999/02/22-rdf-syntax-ns#"
  xmlns:xs="http://www.w3.org/2001/XMLSchema#"
  xmlns:owl="http://www.w3.org/2002/07/owl#"
  xmlns:rdfs="http://www.w3.org/2000/01/rdf-schema#"
  xmlns="http://www.hozo.jp/owl/Flipped_classroom.owl#"
  xml:base="http://www.hozo.jp/owl/Flipped_classroom.owl#"
>
  <owl:Ontology rdf:about="">
    <rdfs:comment>
      HOZO:OWL Export
    </rdfs:comment>
  </owl:Ontology>

  <owl:Class rdf:ID="RelationalConcept">
    <rdfs:label>RelationalConcept</rdfs:label>
  </owl:Class>
  <owl:ObjectProperty rdf:ID="hasPart">
    <rdfs:label>hasPart</rdfs:label>
  </owl:ObjectProperty>
  <owl:ObjectProperty rdf:ID="hasAttribute">
    <rdfs:label>hasAttribute</rdfs:label>
  </owl:ObjectProperty>
  <owl:Class rdf:ID="Any">
    <rdfs:label>Any</rdfs:label>
  </owl:Class>
  <owl:Class rdf:ID="CourseWare">
    <rdfs:label>CourseWare</rdfs:label>

    <rdfs:subPropertyOf rdf:resource="#hasPart" />
    <rdfs:domain rdf:resource="#Standard_Features" />
  </owl:ObjectProperty>
  <owl:ObjectProperty rdf:ID="has_Lecture_Notes">
    <rdfs:subPropertyOf rdf:resource="#hasPart" />
    <rdfs:domain rdf:resource="#Standard_Features" />
  </owl:ObjectProperty>
  <owl:ObjectProperty rdf:ID="has_User_attendance_and_tracking">
    <rdfs:subPropertyOf rdf:resource="#hasPart" />
    <rdfs:domain rdf:resource="#Standard_Features" />
  </owl:ObjectProperty>
  <owl:ObjectProperty rdf:ID="has_Locking_and_Hiding_of_activity">
    <rdfs:subPropertyOf rdf:resource="#hasPart" />
    <rdfs:domain rdf:resource="#Standard_Features" />
  </owl:ObjectProperty>
  <owl:ObjectProperty rdf:ID="has_Announcement">
    <rdfs:subPropertyOf rdf:resource="#hasPart" />
    <rdfs:domain rdf:resource="#Standard_Features" />
  </owl:ObjectProperty>
  <owl:ObjectProperty rdf:ID="has_Mobile_Support">
    <rdfs:subPropertyOf rdf:resource="#hasPart" />
    <rdfs:domain rdf:resource="#Standard_Features" />
  </owl:ObjectProperty>

  <owl:Class rdf:ID="UndefinedClass">
    <rdfs:label>UndefinedClass</rdfs:label>
  </owl:Class>
</rdf:RDF>

```

Figure 3. OWL document file

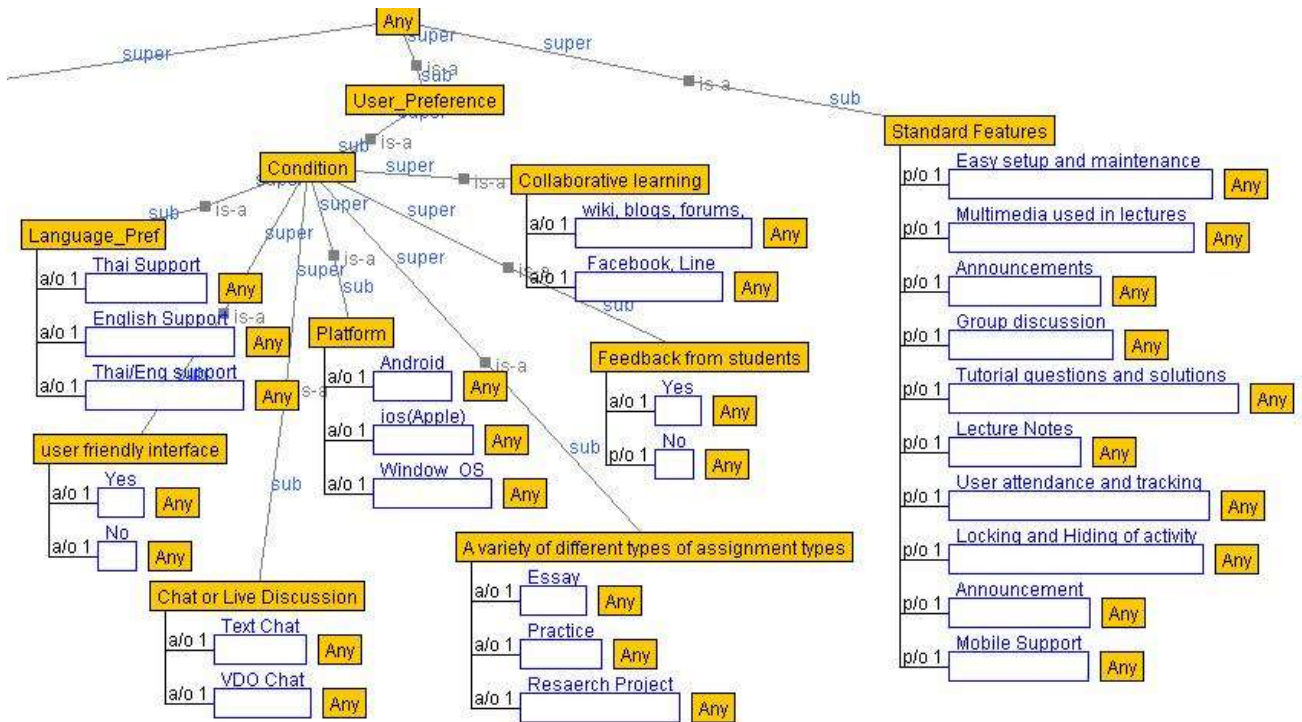

Figure 1. User Preference and Standard Features

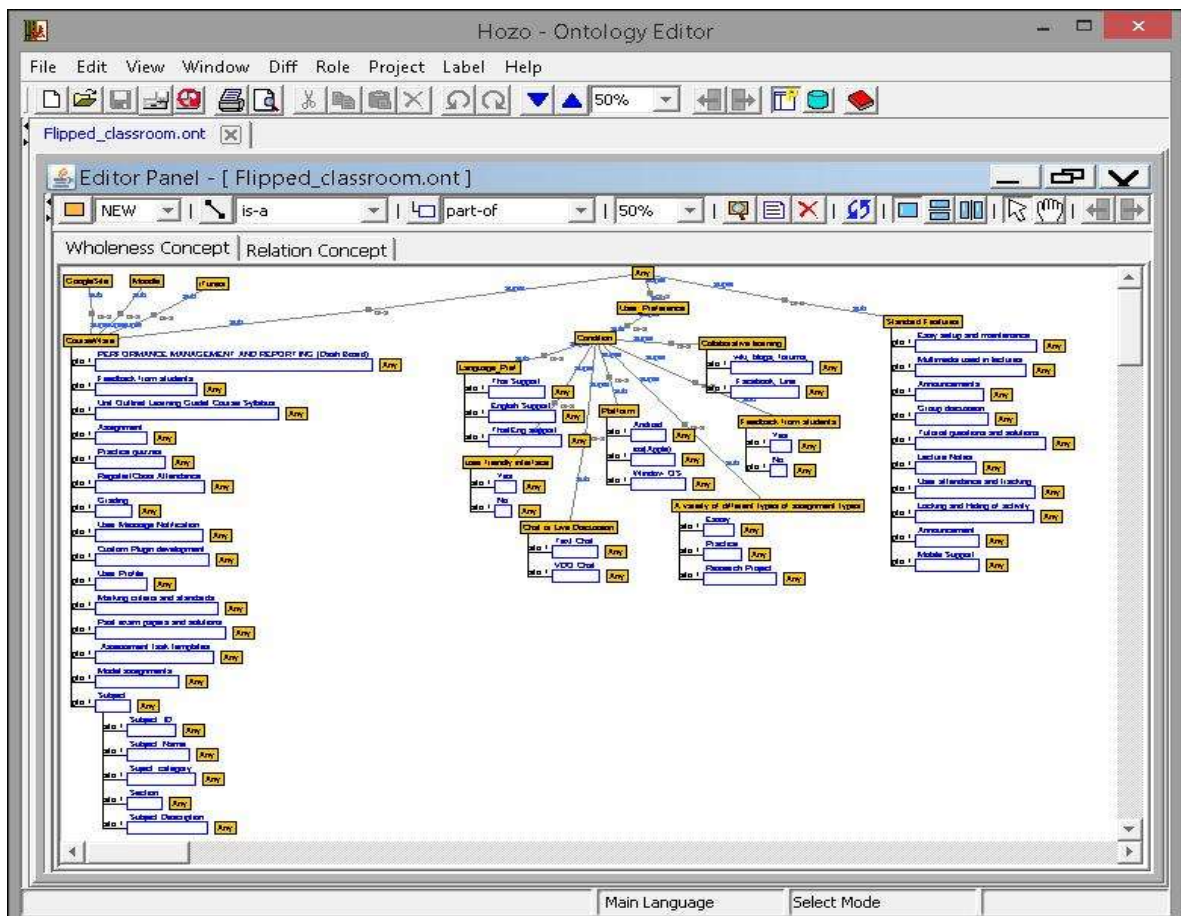

Figure 2. Overall Ontology

IV EXPERIMENT

Questionnaires were distributed to 2500 out of 8000 fleshy Thai students of bachelor, master or Ph.D. student in 2015. After having collected data for 4 months, we get 1,235 user complete questionnaires in total. There are 7 features that are in the questionnaire. All questions in the questionnaire are designed to answer those mined rules. The Apriori algorithm was applied by using WEKA tool with control parameter of Min_Sup=10%, Min_Conf=80% and lift>1.1 (University of Waikato 2015). The experimental result is follows:

Feature4="Available" → Courseware
Enrollment='Y' [11%, 0.88]
Feature5="Available" → Courseware
Enrollment='Y' [18%, 0.81]
Feature6="Available" → Courseware
Enrollment='Y' [22%, 0.82]
Feature4&5="Available" → Courseware
Enrollment='Y' [12%, 0.81]
Feature4&6="Available" → Courseware
Enrollment='Y' [22%, 0.80]
Feature5&6="Available" → Courseware
Enrollment='Y' [13%, 0.81]
Feature4&5&6="Available" → Courseware
Enrollment='Y' [11%, 0.81] (5)

Since we set min_conf > 0.8, all results will show all rules that have their confidence values above 0.8. According to an experimental result, it shows that students like to have contents in Thai and they concerns most. Since Lift are all greater than 1 therefore they are highly dependent each other. We can conclude that all three features are influential to students.

Hozo-Ontology Editor is a graphical ontology editor. It was developed by Osaka University, and Enegate Co, Ltd (Mizoguchi, 2007). It can support Resource Description Framework (RDF), Ontology Web Language (OWL), Extensive Markup Language (XML) and a standard of W3C (Mizoguchi, 2007). Ontology will be used for semantic search and knowledge representation with another information system. Moreover, human and the computer can understand. As XML based file, most of search engines are able to read and understand its meaning.

V CONCLUSIONS AND FUTURE WORK

Ontology technology can handle huge amount of unstructured contents like e-learning. It can represent and capture knowledge of user preference better than a relational database. In this paper, a user preference can be varied in each different environment; therefore, it

has no certain forms or answers. As shown in Figure 1 and 2, all details cannot store in a regular relational database because of their unstructured data. The immediate benefit of an ontology based user preference is to search more effectively (Inthiran, Alhashmi & Ahmed, 2010). Since there are more than 3000 courses offering each semester, an ontology based user preference is a new good ways to help all students can search for their data. If we can understand student's needs, we can serve better. An association rule (Data Mining) is applied to find out factors and conditions that lead to decision to choose a service. Due to its benefit to search engine, OWL format is chosen as a file format for this paper. Our experimental results show high percentages of confidence and lift values above 80% and greater than 1 respectively. From those relationships, we can construct an ontology for user preference as OWL format.

An advisor system is viable for students to adopt the courseware (so called services). It is a preliminary step to choose courseware service in universities. Before constructing an advisor system, we need to know user preference. An advisor system will be a future work for next research.

REFERENCES

- Abeysekera, L. and Dawson, P. (2015). Motivation and cognitive load in the flipped classroom: definition, rationale and a call for research. *Higher Education Research & Development* 34(1), 1-14.
- Maedche, A. and Staab, S. (2001). Ontology learning for the Semantic Web. *IEEE Intelligent Systems*, 16(2):72-79, 2001..
- Chandrasekaran, B., Josephson, J. R., Richard, B. V., (1998) Ontology of Tasks and Methods, In Workshop on Knowledge Acquisition, Modeling and Management (KAW'98), Canada.
- Deborah L. McGuinness and Frank van Harmelen (2004). OWL Web Ontology Language Overview, Editors, W3C Recommendation, 10 February 2004, Available: <http://www.w3.org/TR/owl-features/>.
- Nahar, J., Imam, T., Tickle, K. S., and Chen Y. P. P. (2013), Association rule mining to detect factors which contribute to heart disease in male and female, *Expert System with Application*, pp 1086-1093
- Chau, K. W., (2007), An ontology-based knowledge management system for flow and water quality modeling, *Advances in Engineering Software* 38 (3) pp. 172-181.
- Mizoguchi R., Sunagawa E., Kozaki K. and Kitamura Y. (2007). A Model of Roles within an Ontology Development Tool: Hozo. *Journal of Applied Ontology*, 2(2):159-179.
- Ramana, V. (2002). Taxonomies, Categorization and Organizational Agility, Best Practices in Enterprise Knowledge Management, Volume II, A Supplement to KMWorld, Vol 11, Issu9.
- Inthiran, A., Alhashmi, S., & Ahmed, P. (2010). A Reflection of Current Search Engine Techniques on Medical Search Environments. Sixth International Conference on Intelligent Environments (IE), 2010 (pp. 170-173). Kuala Lumpur: IEEE
- Zhao, Y., Wang, X., and Halang, W., (2006), Ontology Mapping based on Rough Formal Concept Analysis, Advanced Int'l Conference on Telecommunications and Int'l Conference on Internet and Web Applications and Services (AICT-ICIW'06), pp. 180-186
- Weka 3. Data Mining Software in Java, (2013) University of Waikato, Available: <http://www.cs.waikato.ac.nz/ml/weka/>

An Experiment on the Performance of Shortest Path Algorithm

Simon Chan Yew Meng, Nur'ayuni Adnan, Syazwan Syafiqah Sukri, and Wan Mohd Nazmee Wan Zainon

Universiti Sains Malaysia, Malaysia

{simon.ucom13; ayuni.ucom13; ssyafiqah.ucom13}@student.usm.my, nazmee@usm.my

ABSTRACT

Shortest path algorithms are one of the main algorithms used in most navigation system. By implementing these algorithm, the related overall costs such as time and work load can be minimized. The main objective of this paper is to study and experiment the different shortest path algorithm such as Dijkstra's algorithm, Symmetrical Dijkstra's algorithm, A* algorithm, Bellman-Ford algorithm, Floyd-Warshall algorithm and Genetic algorithm in solving the shortest path problem. In this paper, a brief review on each of the shortest path algorithm and its implementation method was discussed. Explanation on how the experiment was conducted and the sample data that involved in the experiment were also presented. The result of the experiment shows the overall performance of each algorithm in solving shortest path problem in term of running time and total distances. The analysis of result shows the performance of each algorithm in order to suggest the most efficient algorithm in solving the shortest path problem.

Keywords: Dijkstra's algorithm, Symmetrical Dijkstra's algorithm, Bellman-Ford algorithm, A* algorithm, Floyd-Warshall algorithm, Genetic algorithm

I INTRODUCTION

Shortest path problem is one of an interesting topic and widely researched until these days. The shortest path problem involve in finding shortest route from a starting point to a destination point (Magzhan & Jani, 2013). This problem is widely applied for GPS routing system, network routing system and logistic automation (Beker et.al., 2012). The aim of solving shortest path problem is to improve the productivity as well as save cost and time. Currently there are many shortest path algorithms that has been proposed by the researcher to solve the shortest path problem. Each of these proposed algorithms has its own method to solve the problem and each algorithm has its advantages and disadvantages over each other depends on the situation it is used. Thus, it is important to study about the characteristic of these algorithms and able to choose the right algorithm that suits each situation especially when users want to

implemented it to solve the shortest path problem since using unsuitable algorithm could lead to time wasting and inaccurate result. In this paper, there are several shortest path algorithm that will be discussed;

- 1) Dijkstra's Algorithm
- 2) Symmetrical Dijkstra's Algorithm
- 3) A* Algorithm
- 4) Bellman-Ford Algorithm
- 5) Floyd-Warshall Algorithm
- 6) Genetic Algorithm

The goal of this research is compare these six algorithms in term of their performance, accuracy and understand their characteristic. In the process, it will try to determine the most efficient algorithm to solve the shortest path problem. To achieve this, we have conducted an experiment to test the performance of the algorithm in different situation.

II LITERATURE REVIEW

As mention earlier, every shortest path algorithm has its own unique characteristic and method in solving the shortest path problem. In this section, the brief description and implementations of six proposed shortest path algorithm will be presented.

1) *Dijkstra's Algorithm*: Dijkstra's algorithm is a shortest path algorithm discovered by E.W. Dijkstra (Morris, 2016) (Zhang et. al., 2005), used to solve the single-source shortest-path problem when all edges have non-negative weights. In a graph, the algorithm starts at the starting node and grows a tree that ultimately spans all nodes reachable from the starting node. The algorithm will works iteratively where in each iterative it visits the node with shortest distance path from the starting node and then revalue the path distance of remaining unvisited node. This process will keep repeated until the destination node was visited (Zhang et. al., 2005). In overall, the Dijkstra's algorithm has running complexity of $O(n^2)$. One of the advantage of Dijkstra's algorithm is the algorithm will be terminated once the destination node has reached and without need to visit the remaining unvisited node. In other hand, the disadvantage of Dijkstra's algorithm is difficult to be implemented on computer program when the number of node is very large because it will consume a lot of CPU memory in order to compute it (Aghaei et. al., 2009).

2) *Symmetrical Dijkstra's Algorithm*: Symmetrical Dijkstra's algorithm was invented by Pohl where the algorithm was derived from the Dijkstra algorithm (Zhang et. al., 2005) by implementing the bi-directional search method into it. The process of Symmetrical Dijkstra's algorithm was similar to the original one with addition of a forward search from the origin node to the destination node and a backward search from the destination node to the origin node. The process of algorithm will terminated when forward search and backward search meet at certain node. According to Pohl, this algorithm was invented in attempt to reduce the running complexity of Dijkstra's algorithm from $O(N^b)$ to $O(N^{b/2})$. But in worst case scenario, the running complexity of the algorithm could become two $O(N^b)$ searches.

3) *A* Algorithm*: A* algorithm was invented by Hart and Nilsson (Mitchell, 1999) where the algorithm implement the concept of integrating a heuristic into the search procedure. The A* algorithm was working as similar as the Dijkstra's algorithm except for its difference heuristic controls in choosing the node for every iteration. Rather than choosing the node with shortest distance path from starting node, the A* algorithm will choose the node based on its distance path from starting node with addition heuristic estimation of its proximity to the destination node (Beker et.al., 2012) (Cho et. al., 2013). The heuristic estimation was evaluated by one of two main evaluation functions, which were the Euclidean distance and the Manhattan distance (Zhang et. al., 2005). The Euclidean distance is calculated by the length of straight line between the evaluated node and the destination node, while the Manhattan distance evaluated by the sum of distance in the X and Y coordinates of both nodes. Through the usage of these heuristic, the A* algorithm will cause the shortest path tree expanded toward to the destination node instead of expand the tree radially using the Dijkstra's algorithm. As results, A* algorithm has reduce the search space require to reach the destination node compare to Dijkstra's algorithm. This shows that A* algorithm will have better performance compare to Dijkstra's algorithm unless its heuristic was less accurate.

4) *Bellman-Ford Algorithm*: Bellman-Ford algorithm was developed by Richard E. Bellman and Lester R. Ford, Jr (Stoimen, 2016). It is suitable to be implemented to solve the shortest path problem when the graph contains negative value edges (Beker et.al., 2012) (Schrijver, 2012) (Glabowski et. al., 2013). This algorithm works iteratively where its number of iteration was based on the number of edges path from

starting node to destination node. For each iteration, every of the last visited node will transverse to its nearby node and label it with the most optimal distance path from the starting node. The running complexity of Bellman-Ford algorithm is $O(NA)$ where $(N + 1)$ is the number of iterations and A is the number of edges in the graph.

5) *Floyd-Warshall Algorithm*: Floyd-Warshall algorithm was discovered by Bernard Roy and Stephen Warshall (Weisstein, 2016). It works by finding the shortest distance path between all of pairs of nodes in a graph (Beker et.al., 2012). The running complexity of Floyd-Warshall algorithm is $O(N^3)$. Besides that, Floyd-Warshall algorithm was also explained as one of the few algorithms that able to solve the shortest path problem in a graph that contains negative values edges and without the existed of negative edges cycle. The main advantage of Floyd-Warshall algorithm is able to obtain the shortest distance between any two nodes (Cho, 2013). In other hand, this algorithm is simple and easy to implement into the program but it was not suitable for solving shortest path problem in large network because its running complexity is too high for the calculation.

6) *Genetic Algorithm*: Genetic algorithm was invented by John Holland in the 1960s and then developed by him and his students and colleagues at the University of Michigan in the 1960s and the 1970s (Mitchell, 2016). This intelligent algorithm was invented to solve the shortest path problem in a flexible situation that has a very large search space and constant changing environment (Magzhan & Jani, 2013). In addition, it also defines as a stochastic search algorithm that based on the biological evolution and used to produce a most optimizes results. The genetic algorithm works by produce a set of solution which is known as the population where each of it was evaluated by its own fitness value. Then, the population will goes through several genetic operations such as selection, crossover and mutation in order to generate a new generation of population that supposed to have better fitness value compare to the previous one. After going through specific number of generations, the population with the most optimal fitness value will be chosen as the solution of the problem.

III EXPERIMENT IMPLEMENTATION

In this research, the experiment has been conducted using a special application developed in Java. The sample data that used to test the shortest path algorithm is the existing bus route of Penang area. This experiment stimulates the navigation system to

find the shortest path from the origin to the destination using the proposed algorithm. Through this experiment, the proposed algorithm will be tested in different situation such as using large sample data versus small sample data, traveling long journey versus short journey and implementation of genetic algorithm with different number of generation. Figure 1 and 2 show the large sample data and small sample data respectively.

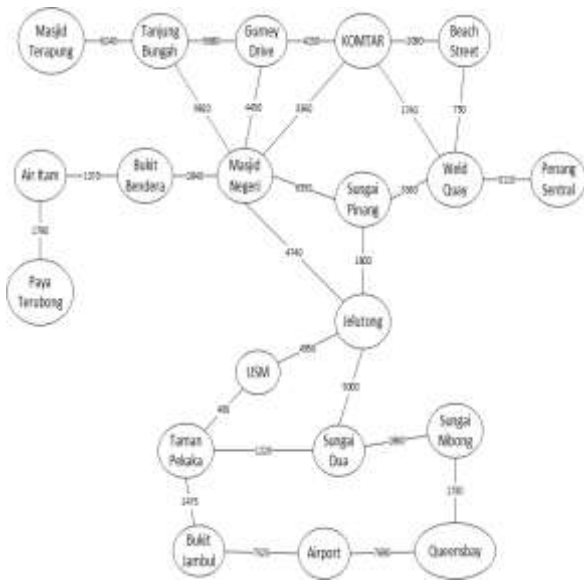

Figure 1. Large Sample Data

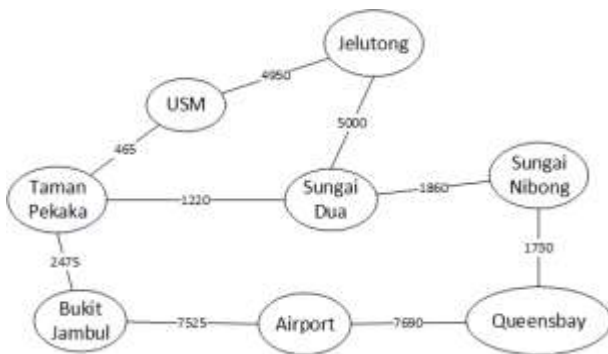

Figure 2. Small Sample Data

IV EXPERIMENT RESULT AND ANALYSIS

In order to achieve accurate results, each algorithms performed 20 times for each of the cases of the experiment. Then, the average value was calculated as the final result.

For large data versus small data cases, each algorithm was tested with same origin and destination (Jelutong to Airport) but using the different data set (large sample data and small sample data). The Table 1

shows the performance of each algorithm to solve shortest path problem in term of running time and result distance. The result was divided into two groups, which are large sample data and small sample data.

Table 1. Comparison Of Performance Of Algorithm To Solve Shortest Path Problem For Large Data Versus Small Data Cases

Algorit hm	Small Sample Data		Large Sample Data	
	Runnin g Time (nanose cond)	Total Dista nce (mete r)	Runnin g Time (nanose cond)	Total Dista nce (mete r)
Dijkstra	55658	18240	321712	18240
Symme trical Dijkstra	27632	18240	144080	18240
A*	43816	18240	322501	18240
Bellma n-Ford	42237	18240	88816	18240
Floyd-Warsha ll	61974	18240	584213	18240
Genetic	863688	18240	865661	18240

The Figure 3 shows the chart to compare the running time of each algorithm to solve shortest path problem for large data and small data cases.

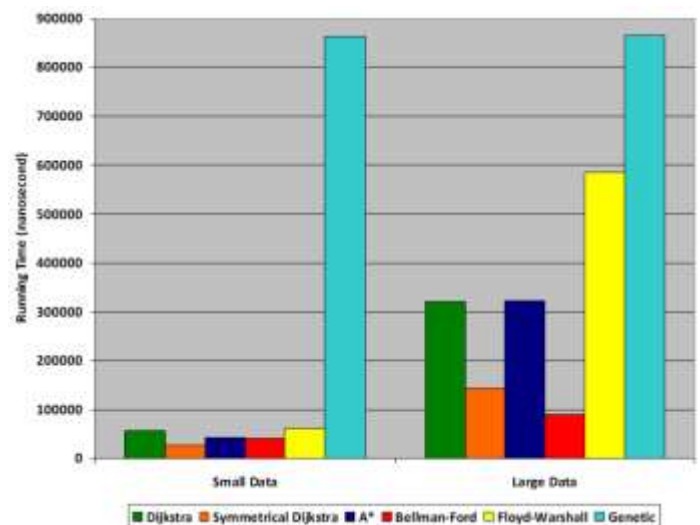

Figure 3. Chart Of Running Time Of Algorithm To Solve Shortest Path Problem For Large Data Versus Small Data Cases

The chart shows that the algorithm solve the shortest path problem using small sample data has much shorter running time compare to using large sample data. This is can be explain by the smaller the data size leads to the lesser the operations of algorithm require to be executing for solving the problem. The genetic algorithm is the exception because its number of operation was based on its generation number rather than the data size. This explains why the running time of genetic algorithm only has slightly different between using large sample data and small sample data.

In small data cases, the symmetrical Dijkstra’s algorithm has the highest performance compare to others. This was follow-up by the Bellman-Ford algorithm, A* algorithm and Dijkstra’s algorithm. In large data cases, the Bellman-Ford algorithm has the shortest running time which was follow-up by the symmetrical Dijkstra’s algorithm, Dijkstra’s algorithm and A* algorithm. In both cases, the genetic algorithm and Floyd-Warshall algorithm has the worst and second worst performance respectively. The performance of genetic algorithm can be explained by its complex operation while the Floyd-Warshall algorithm cases is due to its time complexity of $O(n^3)$. In term of accuracy, the result shows that all algorithms were able to produce the similar and most optimum solution for both small and large data cases.

For long journey versus short journey cases, the experiment was carried out for each algorithm was tested to start at the same origin location and travel to two different destinations, where one is the short journey (Airport to Jelutong) while another one is the long journey (Airport to *Masjid Terapung*). The Table 2 shows the performance of each algorithm to solve shortest path problem in term of running time and result distance. The result was divided into two groups, which are short journey cases and long journey cases.

Table 2: Comparison Of Performance Of Algorithm To Solve Shortest Path Problem For Long Journey Versus Short Journey Cases

Algorithm	Short Journey		Long Journey	
	Running Time (nanosecond)	Total Distance (meter)	Running Time (nanosecond)	Total Distance (meter)
Dijkstra	48553	18240	323291	35469
Symmetrical Dijkstra	37500	18240	219474	35469

a				
A*	63947	18240	230527	22449
Bellman-Ford	100264	18240	89606	22449
Floyd-Warshall	572371	18240	581450	22449
Genetic	797766	18240	1100531	28999

The Figure 4 and 5 shows the chart to compare each algorithm to solve shortest path problem in term of running time for long journey and short journey cases and result distance for long journey cases respectively.

The chart shows that each algorithm except Floyd-Warshall algorithm and Bellman-Ford algorithm, solves the short journey cases of shortest path problem has better performance compare to long journey. The different in performance of algorithm was due to different in path distance between short journey and long journey which resulting the algorithm in short journey cases require to traverse less node in order to reach the destination compare to long journey. The Floyd-Warshall algorithm and Bellman-Ford has the similar running time for both cases due to its requirement to traverse all nodes before able to product the solution.

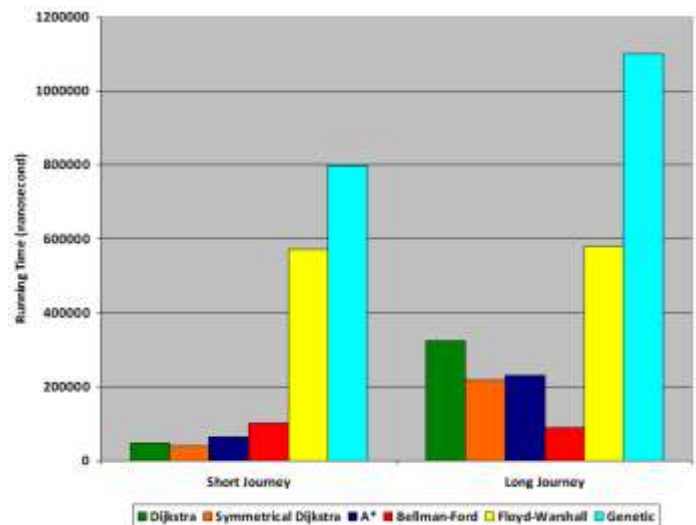

Figure 4. Chart of Running Time of Algorithm to Solve Shortest Path Problem for Long Journey Versus Short Journey Cases

In short journey cases, the symmetrical Dijkstra’s algorithm was shows to have the shortest running

time while the second runner up was Dijkstra's algorithm. The rest is follow by the A* algorithm and Bellman-Ford algorithm. In long journey cases, the chart shows that Bellman-Ford algorithm has the best performance compare to others. The result was follow-up by symmetrical Dijkstra's algorithm, A* algorithm and Dijkstra's algorithm. In both cases, the genetic algorithm has the worst performance follow-up by the Floyd-Warshall algorithm. Similar to large data versus small data case, the performance of genetic algorithm and Floyd-Warshall algorithm was due to the complex operation and time complexity of $O(n^3)$ respectively.

Based on Table 2, the result shows that the solutions of all algorithms are similar and optimum for short journey cases. For long journey cases, the chart shows that A* algorithm, Bellman-Ford algorithm and Floyd-Warshall algorithm have produce the most optimum solution which is follow-up by the genetic algorithm. For Dijkstra's algorithm and symmetrical Dijkstra's algorithm, both have produced the least optimum solution. The reason Bellman-Ford algorithm and Floyd-Warshall algorithm able produce better solution was because both algorithms able to generate all the possible solution before making comparison to get the best solution. In other hand, the A* algorithm cases can be explained by its implementation of heuristic search.

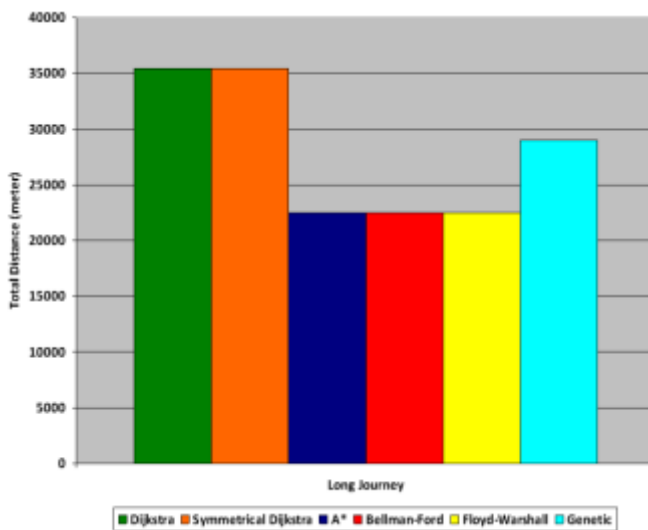

Figure 5. Chart of Result Distance of Algorithm to Solve Shortest Path Problem for Long Journey Cases

The next experiment was to test the performance of genetic algorithm to solve shortest path problem of same cases (Airport to KOMTAR) with implementation of different number of generation. The Table 3 shows the performance of genetic

algorithm with implementation of different number of generation to solve the shortest path algorithm.

Table 3: Comparison Of Performance Of Genetic Algorithm With Implementation Of Different Number Of Generation To Solve Shortest Path Problem

Number of Generation	Running Time (nanosecond)	Total Distance (meter)
5	37106	32359
10	62369	28999
15	63158	22449
20	70263	28999
25	82500	22449
30	94342	19609

The Figure 6 shows the graph to compare the performance of genetic algorithm with implementation of different number of generation to solve the shortest path algorithm.

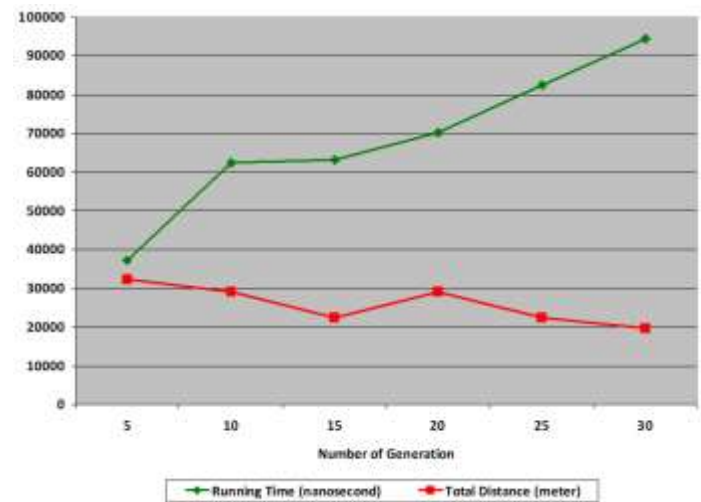

Figure 6. Graph Of Performance Of Genetic Algorithm With Implementation Of Different Number Of Generation To Solve Shortest Path Algorithm

The graph shows that the running time of genetic algorithm increase with its number of generation. This is due to increase in number of operation required to perform by genetic algorithm in order to solve the shortest path problem. In other hand, the graph also shows that the solution provided by the genetic algorithm is inconsistent for each number of generations because the solution produce by the genetic algorithm can be random sometime. As the number of generation increase further, the solution produce by the genetic algorithm was shown to improved and more optimum.

V CONCLUSION AND FUTURE WORK

Based on the experiment results, it shows that most algorithms will achieve better performance when it solves the short journey shortest path problem and using small data size. In exception, the data size will not affect the performance of genetic algorithm. In other hand, the Bellman-Ford algorithm and Floyd-Warshall algorithm will still retain its performance for both short journey and long journey cases. This show that the performance of algorithm can be different in various situations depends on the nature of data and method of algorithm to solve the shortest path problem. In overall, the experiment result shows that the Bellman-Ford algorithm was able to produce the optimum solution using short running time. The result also shows that the performance of Bellman-Ford algorithm was superior to other algorithm in most situations. This clearly indicates that the Bellman-Ford algorithm is the most efficient shortest path algorithm compare to others. In other hand, the genetic algorithm was shown to have highest running time but able to produce the optimum solution in most situation. The experiment shows that performance of genetic algorithm was affected by its number of generation where the larger the number of generation, the higher the running times as well as the better the solution. Thus, it is important to adjust the number of generation until the optimum running time to solution ratio was achieved so that the genetic algorithm can be used in the most efficient manner.

REFERENCES

- Magzhan, K., Jani, H.M. (2013) "A Review and Evaluations of Shortest Path Algorithm", International Journal of Scientific & Technology Research Volume 2, Issue 6.
- Beker, I., Jevtic, V., Dobrilovic, D. (2012) "Shortest-path algorithm as a tools for inner transportation optimization", International Journal of Industrial Engineering and Management (IJIEM), Vol.3 No 1, pp. 39-45.
- Schrijver, A., (2012) "On The History Of The Shortest Path Problem", Documenta Mathematica, extra volume ISMP, pp. 155-167.
- Glabowski, M., Musznicki, B., Nowak, P., and Zwierzykowski, P., (2013) "Efficiency Evaluation of Shortest Path Algorithms", AICT 2013: The Ninth Advanced International Conference on Telecommunications.
- Cho, T., Kim, L., Yoon, W., and Choi, S., (2013) "A Hybrid Routing Algorithm for an Efficient Shortest Path Decision in Network Routing", International Journal of Multimedia and Ubiquitous Engineering, Vol. 8, No. 4.
- Zhang, F., Qiu, A., and Li, Q., (2005) "Improve on Dijkstra Shortest Path Algorithm for Huge Data". Chinese academy of surveying and mapping
- Aghaei, M.R.S., Zukarnain, Z.A., Mamat, A., Zainuddin, H., (2009) "A Hybrid Algorithm for Finding Shortest Path in Network Routing", Journal of Theoretical and Applied Information Technology.
- Morris, J., (2016, February 15) 10.2 Dijkstra's Algorithm. Available from: <https://www.cs.auckland.ac.nz/software/AlgAnim/dijkstra.html>.
- Engineer F. (2001) Fast Shortest Path Algorithms for Large Road Networks. In: Proceedings of 36th annual ORSNZ conference.
- Mitchell, M. (1999) An Introduction to Genetic Algorithms. Cambridge, Massachusetts: Massachusetts Institute of Technology.

- Stoimen. (2016, February 10) Bellman-Ford Shortest Path in a Graph. Available from: <http://www.stoimen.com/blog/2012/10/22/computer-algorithms-bellman-ford-shortest-path-in-a-graph/>
- Weisstein, E... (2016, January 22) Floyd-Warshall Algorithm. Available from: <http://mathworld.wolfram.com/Floyd-WarshallAlgorithm.html>

Improving Employees Retention Rate Through Knowledge Management and Business Intelligence Components

Herison Surbakti¹, and Azman Ta'a²

¹Universitas Respati Yogyakarta (UNRIYO), Indonesia, herisonsurbakticc@gmail.com

²Universiti Utara Malaysia (UUM), Malaysia, azman@uum.edu.my

ABSTRACT

The fundamental thrust of this paper is to uncover certain dimensions of organizational context through Knowledge Management (KM) and Business Intelligence (BI). KM is identified as important antecedent of employee retention that leads to direct their positive attitude toward work place. The structural model indicates that KM and BI strategies integer worker instant to retain. For data collection, the unbiased sources have been used i-e., past literature, journals, and secondary data of discussions with top management and employee's feedback. An analysis of the big data serves as the basis for determining the impact of KM trough BI and using employee retention scale. This paper discusses some reasons for turnover to include components of BI. The problems with so much data from sensors, social media, and online applications often flow and accumulate much faster than humans could possibly analyze or act on it. Further, the lack of analytical system drives organizations to a lot more depends to their employees. Most significant findings for this study demonstrate that the needs of the good analytical system in BI could generalize the training sets of data so that can help the organizations to improving their employees' retention rate.

Keywords: Knowledge Management, Business intelligence, Employee retention rate, Analytical Systems

I INTRODUCTION

Knowledge Management (KM) is opted as strategic tool by executives to keep their team motivated. These teams consist of employees who have higher level of inspiration and competency. In modern era, worker turnover rate is crucial issue for businesses to attain competitive advantage. Employee's retention can be measured by their level of motivation and task orientation in work environment. No organization can compromise for loss of skilled employee because it is much essential than any other source of development. The KM is platform that supports strategic business decisions with people, process, and technology aspects.

It is widely believed that job satisfaction is wholly dependent upon leadership integrity and justified processes of decisions within organization. Thus, intelligence has been a significant factor in managing human capital. It covers all aspects of customer, competitor, markets, technological and environmental intelligence (Surbakti, 2015b). Business Intelligence (BI) is process that generates valuable information with DSS (Decision Support System), data mining and advanced analytics for corporate strategic decisions. It is constant approach for creating and enriching significant information in the managerial context. For knowledge based organizations BI is considered as backbone in organizational structure. It turns data into actionable intelligence for executives to make strategies for work environment stability (Pirttimäki, 2007). Business are keen interested to use latest technology for meeting external and internal competition. BI adopts an effective aid to intelligence practitioners for realizing complete picture of resources in form of humans.

Many past studies have verified that utilizing high association work practices "can boost firm competitiveness" (Nwokocha & Iheriohanma, 2012; Pirttimäki, 2007; Ranjbar & Amiri, 2015). Competitive advantage on the basis of employees is the most focused strategic goal for firms. Executive do believe that it is not so easy to imitate human mind. Skills and abilities take time to reach to a stage where employee's intellectual worth even crosses tangible assets.

Moreover, the use of BI applications for knowledge is the major portion of the enterprise software consists of business intelligence, big data, and data analytics (Chen, Chiang, & Storey, 2012). Most recent example is of the acquisition of WhatsApp for a worth of USD 20 billion by Facebook. WhatsApp has only 32 engineers with 450 million active users. The 72% users are active everyday and its users share 500m photos a day, which is almost certainly more than Facebook (Evans, 2014). This considering as one of the small example of the rising of big data to analyze. For instance, with the rise of big data, the data accumulated from different sources such as; social media and online applications often stream in bulk and are much faster than a human could conceivably analyze or act on it.

Within firms, KM is the heart of progression planning. Businesses that properly manage the alteration of new employees by replacing old ones allow job and industrial information to be transferred through the organization to ensure that such particulars are not lost. Either employees leave organization voluntarily or involuntarily.

As mentioned above, that there's a problem in analyzing the data and act on it, especially the big data, which is with the rise of big data, the data accumulated from different sources such as; social media and online applications often stream in bulk and are much faster than a human could conceivably analyze or act on it.

Certain business concerns included complexity, references to the increasing pace of change, globalization, information flow, economy, networking and proactively. Massive development in the information technology and communications demand to adopt BI applications in order to deal with business mechanisms, staying at the marketplace, rivalry, customer control, and retention.

II LITERATURE REVIEW

In this segment, we present an analysis of the existing literature along with critical assessment of the earlier presented techniques encompassing BI and KM components for most valuable assets of organization.

A. Knowledge Management

Fleig-Palmer & Schoorman (2011) recognized that in future KM linked strategies will operate as a basis of competitive intensity for any business. Knowledge Management is the most influential factor for strategic management of Business Intelligence (Fleig-Palmer & Schoorman, 2011). Knowledge management also closely associates with employee's attitude and behavior toward the job. They will stay with firms where their views and suggestions are given importance.

Knowledge management speaks to strategies, policies, and techniques intended at sustaining an organization's competitiveness by optimizing the environment needed for efficiency enhancement, modernization, and teamwork among employees (Iqbal & Mahmood, 2012).

B. Business Intelligence

BI is recognized as managerial tool used to produce up to date information for strategic decision making (Pirttimäki, 2007).

According to Kanaan, Masa'deh, & Gharibeh (2013), BI is combination of data, knowledge about company's operational environment that leads to creating competitive advantage for business.

BI is viewed as a way and process of improving company performance by giving influential assistance for executive decision maker to allow them to have actionable data and information at hand (Kanaan, Masa'deh, & Gharibeh, 2013). The basic quality for BI tool is that it is talent to collect data from diverse source, to acquire advance analytical methods, and the skill to assist multi user's demands (Ranjan, 2009).

C. Employee Retention

Retention is an intentional move by an organization to build an environment which holds employees for long term (Samuel & Chipunza, 2009). Most of the time when these employees apart, they move to competing organizations with the knowledge and internal secrets obtained from their former organizations (Curado & Bontis, 2007). The improvement has significantly changed human resource performance in the area of attracting accomplished employees into organizations, and most significantly is the strategy for their retention in organization (Yarbrough, Martin, & Alfred, 2016).

If organization gets fail to retain employees then from the outlook of remaining employees, high turnover rates raise their normal workload (Guha & Chakrabarti, 2015).

Such extra burdens increase the stress level of the rest of the team members, employee retention is also defined as loyalty depicted from worker side and fulfillment of satisfaction from employer side (Yarbrough et al., 2016). Employer must care about psychological contracts. Once these contracts are broken employees motivational level is badly effected (Ibrahim, 2015). Their attitude toward the work also starts diminishing (Roblek, Štok, Meško, & Erenda, 2013). There are five reasons for employee not willing to retain in organization (Roblek et al., 2013):

1. Poor recruitment practices
2. Management style
3. Lack of appreciation
4. Lack of competition in the
5. Stressful workplace environment.

D. Turnover

Branham (2005) affirmed that turnover rate can be in brief described as how quick the employers hire and lose employees.

The involuntary turnover refers to the firing of employees, while voluntary turnover occurs when employees resign. While many studies have compared these two divergent classifications, this study is aiming to examine voluntary turnover specifically (Branham, 2005).

It is found that a continually high turnover rate demotivate the remaining employees by inspiring training obligation to them. Motivation and attitude of employees are key factors toward success. Goals and objectives not require systems and machinery but the people who run both (Ranjan, 2009). Hence, organization opt for downsizing, outsourcing etc. instead of turnover (Ranjbar & Amiri, 2015).

III METHODOLOGY

For this empirical research, qualitative research technique is practiced for collection of adequate facts and figures. It included secondary data of self-interviews to executives and managers in corporate sector, evaluation of existing literature and comparison with previous, past researches, journal, and articles and proposed models of BI to empowering KM. Employee's feedback is also considered by secondary data resources while analyzing corporate practical strategies. Past data is also preferred as proof to their performance management activities within organization as financial reports, market share and customer service data bases. All those data are collected through secondary data for this paper purposes.

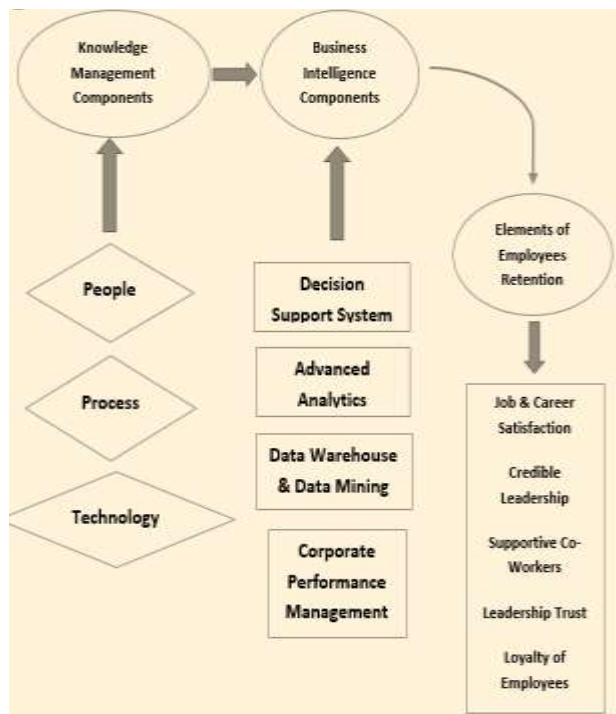

Fig I: Building relationship between components of BI and KM to maximize Employee Retention Rate: Proposed Framework

The question session covers all aspects of BI to empowering the KM significance for organizational competitiveness in market place. Therefore, the following key research questions are proposed:

1. What is the relationship between business intelligence, knowledge management, and employee retention in organizational context?
2. How business intelligence ensure to reduce employees turnover rate?
3. How business intelligence empowering the knowledge?
4. To what extent are BI and KM being used in influencing retention and increase competitiveness?
5. How does Business intelligence control internal and external operations in competitive environment?
6. How efficiently Knowledge management build relation between employee and workplace?

With superior tools of BI, now employees can also easily convert their business information via the systematic intelligence to solve many business issues with technological advancement. In the light of multiple views and arguments, the model is proposed for KM and BI integration. Open ended questions facilitated individuals to openly share their views.

Everyone was welcomed to participate and share his knowledge and experiences. Thus, the role of both fundamental elements are appreciable if practiced effectively but to some extent organizations seem fail to adopt them. People functioning in business intelligence have developed tools that simplify the work, particularly when the intelligence task involves assembly and assessing large quantities of unstructured data.

To obtain desired position in market without effective BI to target process-oriented organizations is not possible. Various problems on re-engineering in business process are being focused. According to Surbakti (2015), enterprises are on track of building BI systems that support in analysis and decision making to better recognize their operations and compete in the marketplace (Surbakti, 2015a).

Further, we examined from certain sources of data that companies still feel that BI has technical complexities and serviceable only by technically specialists. They also feel that BI is costly. BI takes a long time to yield accurate analysis. However, Business Intelligence is becoming need of the organizations who have to handle big data (Gupta, Goul, & Dinter, 2015). Hence, in this research different models regarding data warehouse and data mining.

Data mining is component of BI that is heavily inclined toward traditional statistical techniques and even most data-mining methods reveal a strong base of statistical and data analysis methods. DSS also

come with results of valued processed information that assist management to take business long term decisions. Hence, Employees can be treated in best manners by adopting such strategic tools and can be retained as valuable tangible assets.

IV CONCLUSION AND DISCUSSION

Today's business environment has become very competitive thus making skilled employees the major differentiating factor for most organizations. The present study assumed that managers in the organizations have responsibility to properly recognize and apply motivational variables that can manipulate employees to stay in an Organization.

Replacing existing employee is expensive to organizations and critical to competitiveness. These key (termed knowledge workers) are particularly risky since their value to the organization is fundamentally intangible and not easily simulated. This is why senior management must avoid more loss by codifying intellectual assets in a deliberately planned knowledge management system. By applying a knowledge management strategy, the business can protect them from knowledge erosion. This state of affairs demands corporate executives to consider the consequences of voluntary turnover to create contingent plans.

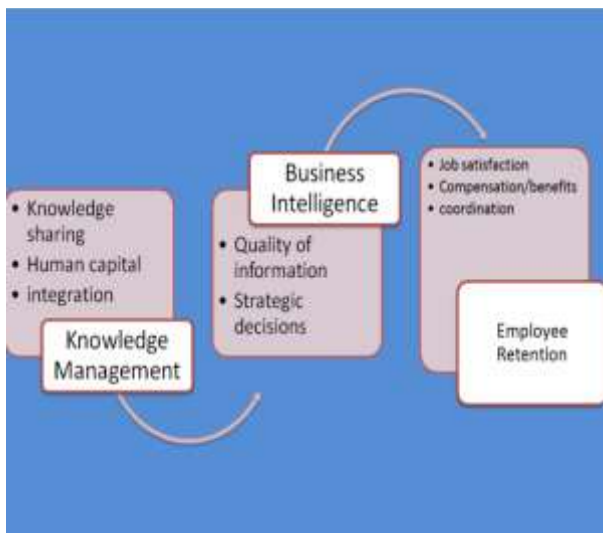

Fig II: Implementation phase of Proposed Model: KM & BI role for employee retention

The above model illustrates that integration of good BI in analyzing big data can improve and empowering the knowledge in organizations. Thus, make possible retention of employee on long term basis. Lack of knowledge sharing among employees and management causes frustration leading to confusion and inefficiencies. Knowledge management and business intelligence emphasize for employees empowerment. Empowered employees have the freedom to participate in decisions within organization. Employment contract highlights the

significance of attracting and maintaining skilled assets as the key to strategic employment in the modern workplace. A lot of firm talent can be lost if the employees experience attentive in dead-end positions.

It is only a comprehensive blend of knowledge management (KM) and business intelligence (BI) motivational variables that can increase retention and diminish the high rate of employee turnover in various organizations.

The paper explored the concepts of BI, its components, concepts of KM, turnover causes and consequences, technology requirements, designing and implementing business intelligence, and various BI tools for competitiveness.

REFERENCES

- Branham, L. (2005). The 7 Hidden Reasons Employees Leave. *Concentrated Knowledge™ for the Busy Executive*, 27(6).
- Chen, H., Chiang, R. H. L., & Storey, V. C. (2012). Business Intelligence And Analytics: From Big Data To Big Impact. *MIS Quarterly*, 36(4), 25.
- Curado, C., & Bontis, N. (2007). Managing intellectual capital: the MIC matrix. *Int. J. Knowledge and Learning*, 3(2/3), 13.
- Evans, B. (2014). Whatsapp and \$19bn.
- Fleig-Palmer, M. M., & Schoorman, F. D. (2011). Trust as a Moderator of the Relationship Between Mentoring and Knowledge Transfer. *Journal of Leadership & Organizational Studies*, 18(3), 334-343. doi:10.1177/1548051811408615
- Guha, S., & Chakrabarti, S. (2015). Effects of Intrinsic and Extrinsic Factors on Voluntary Employee Turnover : An Alternative Exposition. *Anvesha*, 8(3).
- Gupta, B., Goul, M., & Dinter, B. (2015). Business Intelligence and Big Data in Higher Education: Status of a Multi-Year Model Curriculum Development Effort for Business School Undergraduates, MS Graduates, and MBAs. *Communications of the Association for Information Systems*, 36(23).
- Ibrahim, D. (2015). An Overview of Work-Life Management Practices from a Malaysian Perspective. *International Business Management*, 9(4), 10.
- Iqbal, J., & Mahmood, Y. (2012). Reviewing Knowledge Management Literature. *Interdisciplinary Journal Of Contemporary Research In Business*, 4(6), 22.
- Kanaan, R., Masa'deh, R. e. M. d. T., & Gharibeh, A. a. H. (2013). The Impact Of Knowledge Sharing Enablers On Knowledge Sharing Capability: An Empirical Study On Jordanian Telecommunication Firms. *European Scientific Journal*, 9(22).
- Nwokocha, I., & Iheriohanma, E. B. J. (2012). Emerging Trends in Employee Retention Strategies in a Globalizing Economy: Nigeria in Focus. *Asian Social Science*, 8(10). doi:10.5539/ass.v8n10p198
- Pirttimäki, V. H. (2007). Conceptual analysis of business intelligence. *South African Journal of Information Management*, 9(2), 14.
- Ranjan, J. (2009). Business Intelligence: Concepts, Components, Techniques And Benefits. *Journal of Theoretical and Applied Information Technology*, 9(1), 11.
- Ranjbar, M., & Amiri, N. (2015, 16th Aug. 2015). *The Relationship Between Knowledge Management And Employee Retention*. Paper presented at the TheIRES 7th International Conference, Kuala Lumpur.
- Roblek, V., Štok, Z. M., Meško, M., & Erenda, I. (2013). Factors of Knowledge Management and the Impact of Employee Turnover in Activity and Performance in Scientific and Technological Parks in Slovenia. *JIOS*, 37(1).

- Samuel, M. O., & Chipunza, C. (2009). Employee retention and turnover: Using motivational variables as a panacea. *African Journal of Business Management*, 3(8), 7. doi:10.5897/AJBM09.125
- Surbakti, H. (2015a). Integrating Knowledge Management and Business Intelligence Processes for Empowering Government Business Organizations. *International Journal of Computer Applications*, 114(5), 8.
- Surbakti, H. (2015b). *WEB TECHNOLOGY KNOWLEDGE MANAGEMENT AND ITS PRIVACY AND SECURITY CHALLENGE*. Paper presented at the TheIIR International Conference, Singapore.
- Yarbrough, S., Martin, P., & Alfred, D. (2016). Professional values, job satisfaction, career development, and intent to stay. *Nursing Ethics, I-II*. doi:10.1177/0969733015623098

GPU-Based Odd and Even Hybrid String Matching Algorithm

Ghazal Rahbari, Nur'Aini Abdul Rashid, and Wahidah Husain

Universiti Sains Malaysia, Malaysia, {ghazal.rahbari; nuraini; wahidah}@gmail.com

ABSTRACT

String matching is considered as one of the fundamental problems in computer science. Many computer applications provide the string matching utility for their users, and how fast one or more occurrences of a given pattern can be found in a text plays a prominent role in their user satisfaction. Although numerous algorithms and methods are available to solve the string matching problem, the remarkable increase in the amount of data which is produced and stored by modern computational devices demands researchers to find much more efficient ways for dealing with this issue. In this research, the Odd and Even (OE) hybrid string matching algorithm is redesigned to be executed on the Graphics Processing Unit (GPU), which can be utilized to reduce the burden of compute-intensive operations from the Central Processing Unit (CPU). In fact, capabilities of the GPU as a massively parallel processor are employed to enhance the performance of the existing hybrid string matching algorithms. Different types of data are used to evaluate the impact of parallelization and implementation of both algorithms on the GPU. Experimental results indicate that the performance of the hybrid string matching algorithms has been improved, and the speedup, which has been obtained, is considerable enough to suggest the GPU as the suitable platform for these hybrid string-matching algorithms.

Keywords: Odd and Even, Hybrid String Matching, GPGPU.

I INTRODUCTION

String matching is considered as one of the fundamental problems in computer science which involves finding one or more occurrences of a given pattern in a text. Although numerous algorithms and methods are available to solve this problem, many researchers are still trying to achieve much more efficient ways to deal with this issue. Hybrid string matching algorithms, a combination of two or more string matching algorithms, have received a great deal of attention in recent years (Abdurrazag, et al. 2014(Mustafa et al., 2012)). Positive features of the existing string matching algorithms are combined to form a new algorithm in order to improve the searching process. Computer applications which provide string matching utility for their users can take

advantage of this kind of string matching algorithms (Almazroi, 2011). In addition, multi-core Central Processing Units (CPUs) as well as many-core Graphics Processing Units (GPUs) have gained an extensive popularity over the last few years. This development at the hardware level has made an inevitable challenges for researchers who are interested in the string matching problem. Existing sequential string matching algorithms should be redesigned in order to exploit computational power of the modern processors. As a result, execution of the parallelized string matching algorithms on these processors helps decrease the searching time. How the existing sequential hybrid string matching algorithms can be parallelized and implemented on the GPU is the focus of this research.

In this research we analyzed the Odd and Even hybrid string matching algorithm in order to identify the compute-intensive portions of the sequential code, parallelize the hotspots of the selected hybrid string matching algorithm and implement it on the GPU and compare the performance of the sequential version on the CPU with the parallel version on the GPU of the selected hybrid string matching algorithm.

This paper presented the existing works in parallel string matching algorithms in section II. The section III discussed the detail hybrid Odd and Even algorithms, followed by the design of the parallel Odd and Even algorithm. Section V presented the results of the research and we conclude the finding in section VI.

II PARALLEL STRING MATCHING

We studied some of the important work in parallel string matching algorithms (Table 1). Michailidis and Margaritis (2001b) have implemented the Brute Force exact string matching algorithm on a cluster of six personal computers. Noticeable reduction in the execution time has been achieved by using the SPMD parallel programming model over the master-worker paradigm. In their implementation, text is broken down into several subtexts with an overlap of $m-1$ characters, where m is the length of the pattern. Then, these subtexts are assigned to available processors, which perform the string matching procedure simultaneously on their corresponding data, and send their final results to the master processor. They have used a preprocessing allocation method to avoid the load balancing problem which occurs when the subtexts of the database do not have equal length (Michailidis & Margaritis, 2001b).

Parallel implementation of the Naïve, Karp and Rabin, Zhu and Takaoka, Baker and Bird, and Baeza-Yates and Regnier exact two dimensional pattern matching algorithms has been presented by Kouzinopoulos and Margaritis (2009a). These algorithms have been implemented on a multi-core processor and a homogeneous cluster of workstations as shared memory as well as distributed memory parallel platforms by using OpenMP and MPI APIs, respectively. Master-worker distribution method has been applied on both parallel systems. In the shared memory parallelization, it has been shown that the performance is increased when the assignment of the loop iterations to the threads is performed by static scheduling clause compared with dynamic as well as guided scheduling clauses. Moreover, in order to decrease the communication overhead in the distributed memory parallelization, text and pattern are located in the local memory of each processor, which performs the searching process on the corresponding section of the text. This section is determined by the pointer, which has been sent from the master process to the workers (Kouzinopoulos & Margaritis, 2009a).

Table 1. Some of the works in Parallel String Matching Algorithm.

String Matching Algorithm	Parallel Platform	Application Programming Interface (API)
Brute Force	Cluster of 6 Personal Computers	MPI
Naïve Karp and Rabin Zhu and Takaoka Baker and Bird Baeza-Yates and Regnier	A Multi-core Processor and Homogeneous Cluster of Workstations	MPI OpenMP
Knuth-Morris-Pratt Boyer-Moore Boyer-Moore-Horspool Zhu-Takaoka Quick Search Berry-Ravindran Fast Search SSABS TVSBS ZTMBH BRBMH	Homogeneous Cluster of Workstations	MPI
Naïve Knuth-Morris-Pratt Boyer-Moore-Horspool, Quick Search	GPU	CUDA
Boyer-Moore	GPU	CUDA

Parallel execution time of the Knuth-Morris-Pratt, Boyer-Moore, Boyer-Moore- Horspool, Zhu-Takaoka, Quick Search, Berry-Ravindran, Fast Search, SSABS, TVSBS, ZTMBH and BRBMH string matching algorithms have been compared by Prasad and Panicker (2010). Implementation of these algorithms has been performed on a Bewoulf-based homogeneous cluster of workstations with 40 nodes by using MPI API. Based on experimental results of this research, the BRBMH algorithm has the lowest parallel execution time for any pattern lengths as well as text sizes (Prasad & Panicker, 2010).

The Naïve, Knuth-Morris-Pratt, Boyer-Moore-Horspool and Quick Search string matching algorithms have been implemented on the GPU using the CUDA API (Kouzinopoulos & Margaritis, 2009b). In order to calculate the speedup, the practical running time of the algorithms on different data sets as well as different pattern lengths has been measured which includes the preprocessing time, the searching time and the time needed to transfer data between the host and the device. The considerable impact of using the shared memory of the GPU instead of the global memory to store the pattern as well as the pre-computed shift value table of the mentioned algorithms has been illustrated in their research. Moreover, it has been shown that the practical running time reduces by increasing the number of threads in order to keep the GPU entirely utilized (Kouzinopoulos & Margaritis, 2009b). Ryan (n.d.) has implemented the Boyer-Moore string matching algorithm on the GPU using CUDA API. The preprocessing phase of the algorithm is performed on the CPU, while the searching phase is carried out on the GPU. Moreover, the text, the pattern and the pre-processed shift value tables are transferred from the host to the device and stored in global, constant and texture memories, respectively. The performance of the parallel algorithm has been analyzed by using the maximum number of available blocks. Also, it has been shown that transferring the data from the CPU to the GPU decreases the searching time much more than using the page-locked CPU memory which is accessible directly by the CUDA kernel running on the GPU (Ryan, K., n.d.). Other works on parallelizing the string matching algorithms include Naser, M. A. (2010), Atheer Akram AbdulRazzaq et.al, (2013), Abdulwahab and Nur'Aini (2011), Atheer , Nur'Aini and Aziz Nasser Boraik Ali (2013) and Awsan et. al. (2013).

Based on our study, the Odd and Even hybrid string matching algorithms have been selected to be parallelized and implemented on the CPU+GPU parallel platform with the CUDA programming interface. The Odd and Even hybrid string matching algorithm makes an efficient use of the Berry-Ravindran algorithm. It has been compared with the BMH, the QS, the TVSBS, the BRFS, the BRBMH, and the BRQS algorithms and provided better results for searching any lengths of the pattern string and any sizes of the character set (Naser, 2010). The preprocessing phase of both mentioned algorithms is executed once before the searching phase which needs to be run repeatedly as a single program on a huge amount of data. This part of the string matching algorithms is capable of being parallelized to be executed simultaneously on different sections of data which leads to a better performance by decreasing the

searching time. Parallel version of each mentioned algorithms is implemented on the GPU which is based on the SPMD parallel programming model. Its particular architecture is suitable for data parallel applications which involve string matching algorithms. The searching process can be accelerated by using a large number of the GPU threads to execute the searching phase of the string matching algorithms concurrently on independent parts of the text string. Although the BR algorithm has been parallelized and implemented on the shared memory as well as the distributed memory parallel platforms, both mentioned algorithms have not been implemented on the GPU before.

III ODD AND EVEN ALGORITHM

The Odd and Even algorithm is a hybrid string matching algorithm with a similar preprocessing phase to the Berry-Ravindran algorithm. The comparison between the text characters as well as the pattern characters is performed from right to left with a specific order which is described in the following subsection. This characteristic of the OE algorithm has a considerable impact on the performance. Similar to the Berry-Ravindran algorithm, the searching phase starts from the leftmost character of the text without checking the possible starting search point.

Table 2. Odd and Even Bad Character Shift Value Table.

brBc	a	c	g	*
a	10	10	2	10
c	7	10	9	10
g	1	1	1	1
*	10	10	9	10

A. Pre-processing

In the preprocessing phase of the OE algorithm, shift values are computed based on each pair of characters belonging to the pattern string. This feature makes the preprocessing phase of the OE algorithm different from the preprocessing phase of the Berry-Ravindran algorithm although the former applies the same formula as the latter to construct the bad character shift value table. In other words, the preprocessing phase of the Berry-Ravindran algorithm has been enhanced in the OE algorithm which results in reducing the total execution time as well as the reserved memory size of the computer. The bad character shift value table of the OE algorithm based on a pattern string “gcagag” of length 8 as well as a character set (a,c,g,t) of size 4 is shown in Table 2.

B. Searching

In the searching phase of the OE algorithm, the leftmost character of the pattern is aligned with the leftmost character of the text. Then, the comparison

between the text characters as well as the pattern characters is performed from right to left. Even positions of the pattern are compared with the corresponding text characters after the odd positions of the pattern match the corresponding text characters, or vice versa. In case of a mismatch or a complete match, two consecutive characters next to the right side of the window are used to achieve the shift value from the bad character shift value table in order to move the pattern along the text. This procedure is repeated until the right end of the pattern exceeds the right end of the text.

The searching process of a pattern string “gcagag” of length 8 through a text string “tctgtgaggattgattgcagag” of length 24 in one attempt based on the bad character shift value table, which has been constructed in the previous subsection, is illustrated in Figure 1.

IV METHODOLOGY

The methodology of this research consists of five steps. It starts with studying various existing hybrid string matching algorithms. The Odd and Even hybrid string matching algorithm, which has its own advantages and disadvantages, has been selected to be parallelized and implemented on the GPU (Samsudin, 2011),(Charras, & Lecroq, 2004),(Klaib & Osborne, 2009b). Similar to many other hybrid string matching algorithms, the OE algorithm takes advantage of the mentioned characteristic of the BR algorithm, but it provides better results for searching any lengths of a pattern string and any size of a character set compared with them), (Klaib & Osborne, 2009b).

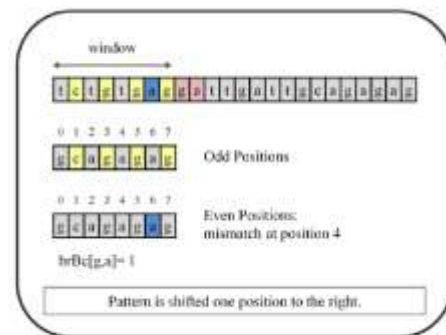

Figure 1. Searching Phase of Odd and Even Algorithm.

The second step involves analyzing the sequential version of the selected hybrid string matching algorithm to identify the compute-intensive portions of the serial code. This sequential version is considered as a baseline, which the parallel version is compared with.

The third step consists of designing the parallel version of the OE hybrid string matching algorithm. In fact, hotspot of the sequential version of the mentioned algorithm is parallelized.

In order to parallelize the string matching algorithm, it is necessary to determine how the problem can be decomposed into smaller parts. Data decomposition technique is used to divide the data which the string matching algorithm must deal with. Then, the searching operation is performed on different parts of the data which are independent of each other. Partitioning the text string into the discrete subtexts leads to a problem which occurs when the pattern string is located in the boundary of adjacent subtexts. Therefore, the pattern string cannot be detected, and a false negative result is returned by the string matching algorithm. An overlap of $m-1$ characters between consecutive subtexts is used to solve the mentioned problem, where m is the length of the pattern string. Since the searching function is performed on all subtexts of the text string simultaneously, Single Program Multiple Data (SPMD) as the most appropriate parallel programming model is used here.

The CUDA API provides different ways to allocate memory on the CPU as well as the GPU. The CPU pageable memory is allocated by the `malloc()` function, while the CPU page-locked memory is allocated by the `cudaMallocHost()` function. In this implementation, the CPU memory allocation is performed by the `malloc()` function. Although the page-locked memory is accessed by the GPU with higher bandwidth than the pageable memory, the system performance can be reduced if an excessive amount of page-locked memory is allocated by the CUDA subroutine which results in decreasing the amount of physical memory available to the operating system for paging. Moreover, the `cudaMalloc()` function is used to allocate the GPU memory in order to store the text string of both string matching algorithms. Data transfer between the host and the device is performed by the `cudaMemcpy()` function. The text string which is needed to be shared by all the GPU threads is transferred from the CPU to the GPU by the mentioned synchronous CUDA subroutine which blocks the CPU threads until the data has been transferred completely and stored in the GPU global memory space. The `cudaMemcpyToSymbol()` function is used to copy the pattern string of both string matching algorithms from the host to the device which is located in the GPU constant memory space. The character set of both string matching algorithms is also transferred from the host to the device by the `cudaMemcpyToSymbol()` function and resides in the constant memory space. Similar to the text string, the pattern string and the character set are needed to be accessed by all the GPU threads. Finally, the texture memory space of the GPU is used to store the shift value table which is constructed by the preprocessing function on the CPU. Therefore, each thread can achieve the corresponding shift value through the texture memory which can be read by all the GPU

threads during the execution of the searching function. In addition, the result of the searching function which includes the number of occurrences of the given pattern string in the text string is transferred from the GPU to the CPU. The GPU memory allocation which is used for the implementation of the parallel the Odd and Even hybrid string matching algorithms is shown in Figure 2.

On the NVIDIA Tesla C2050, which is used in this implementation, data is transferred between the CPU and the GPU through the $\text{PCIe} \times 16$ Gen2 bus with the theoretical maximum bandwidth of 8 GBps. This program has been executed with the pageable CPU memory space against the NVIDIA Tesla C2050.

In this implementation, the preprocessing function which calculates the shift values of the string matching algorithm is executed sequentially on the CPU, while the searching function is executed N times by N threads in parallel on the GPU. The device function, which is specified by the two parameters inside the triple angle brackets, is called from the host code. These two parameters represent the number of blocks and the number of threads. The maximum number of these two parameters depends on capabilities of the GPU on which the device code is executed.

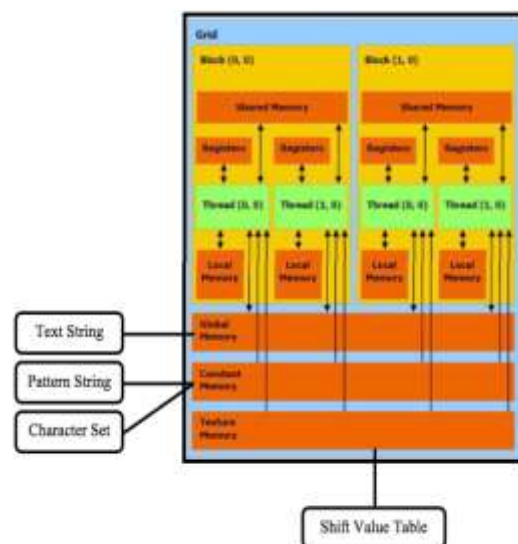

Figure 2. GPU Memory Allocation in the String Matching Problem. Threads within a same block can communicate with each other through the shared memory which is not accessible by threads in other blocks. In the implementation of the parallel Odd and Even hybrid string matching algorithms, each thread of a single block executes the searching function independently and writes the number of occurrences of the given pattern string in its corresponding subtext in the shared memory. In order to avoid the wrong result, threads within a same block must be synchronized which is performed by the `__syncthreads()` function

before the total number of occurrences is computed. Furthermore, the `atomicAdd()` function is used to compute the final result of the device code by adding the total number of occurrences of the given pattern string which has been calculated by each block. This function is used to prevent race condition from happening. Implementation of the parallel Odd and Even hybrid string matching algorithms on the CPU+GPU parallel platform is shown in Figure 3.

The fourth step involves implementing the parallel version of the selected hybrid string matching algorithm on the CPU+GPU parallel platform. CUDA programming interface, which has been designed for only NVIDIA's GPUs, is used in this implementation. Karimi, Dickson, and Hamze (2011) have compared the performance of CUDA as well as OpenCL programming interfaces in terms of data transfer times, kernel execution times, and application execution times by using almost identical kernels and have suggested CUDA as a better choice.

Finally, the sequential version as well as the parallel version of the OE hybrid string matching algorithm are tested on the standard data types which consist of English text, protein sequence, and DNA sequence. Execution time, speedup, and percentage of performance gain which are considered as the performance metrics of the parallel system will be calculated and evaluated in this step. The execution time is divided into serial runtime and parallel runtime. They are the execution time of the sequential algorithm and the parallel algorithm, respectively. The speedup is used to determine how much faster the parallel code executes in comparison with the best sequential code, while the percentage of performance gain is applied to specify how much performance is obtained by parallelizing the sequential algorithm (Grama, Gupta, Karypis, & Kumar, 2003), (Naser, 2010).

V RESULTS AND DISCUSSION

The correctness of the parallel version of the Odd and Even algorithm has been checked by comparing the number of occurrences of a given pattern string in a text string with the result which has been obtained by executing the sequential version of the mentioned algorithm with the same pattern as well as the same text.

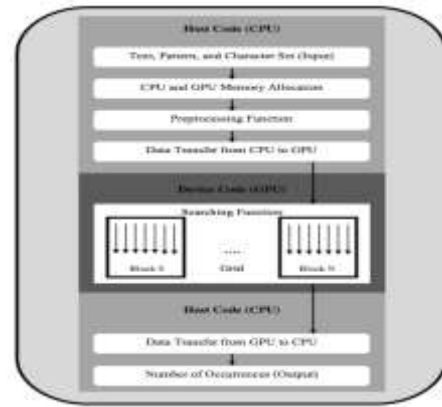

Figure 3. Implementation of the String Matching Algorithm on GPU.

The searching phase of the algorithm has been parallelized. Therefore, the sequential runtime and the parallel runtime of the algorithm, which are compared together, do not include the preprocessing phase. The elapsed time from the start to the end of the searching function on the sequential platform is measured as the sequential runtime. The parallel runtime includes the time of the data transfer from the CPU to the GPU, execution of the searching function on the parallel platform, and the data transfer from the GPU to the CPU.

The program is executed five times, and the average of the obtained values, which are shown in Appendix D, is calculated in order to decrease the random variation. In addition, the sequential and the parallel versions of the algorithm are tested on English text, protein sequence, and DNA sequence data types with five different sizes of 100, 200, 300, 400, and 500 MB (Naser, 2010). The program is executed with an 8-character pattern string which is selected randomly from the corresponding text string (Samsudin, 2011). The character set of the pattern string has been obtained by running the program which can be used to achieve all the different characters of the pattern string as well as the size of the character set.

The number of blocks per grid and the number of threads per block as the kernel parameters are set to 14 and 768, respectively. Selected kernel parameters have been tested by the NVIDIA Corporation's occupancy calculator and resulted in 100% occupancy.

Experimental results of this research, as shown in Table 3, which indicates the performance of Odd and Even string matching algorithms on different standard data types has been enhanced considerably by using the CPU+GPU parallel platform.

The performance improvement of Odd and Even is more than 90 percent on English text and protein sequence and between 80 and 90 percent on DNA sequence data types.

Unavoidable flow control instructions of the parallel

OE algorithm which leads to the thread divergence problem prevent it from running faster and have good speed-up.

Experimental results of running the sequential and the parallel versions of the Odd and Even hybrid string matching algorithm has been evaluated. Sequential and parallel version of this algorithm has been executed on English text, protein sequence, and DNA sequence data types as the standard benchmark with different sizes. Then, execution time, speedup, and percentage of performance gain have been calculated in order to determine the impact of parallelization on the performance of these hybrid string matching algorithms.

Obtained results confirm that the parallel version of the algorithm runs faster on the GPU than its sequential version on all three mentioned data types. Therefore, GPU capabilities can be exploited to enhance the performance of the hybrid string matching algorithms. Moreover, in order to make better use of the GPU, the flow control instructions must be used as less as possible in the device code to avoid the thread divergence problem, which has a substantial influence on the performance of the program.

Table 3. Performance Improvement of Odd and Even Algorithm.

Data Type	Text Size (MB)	Performance Improvement
English Text	100	93.83%
	200	93.77%
	300	93.91%
	400	93.55%
	500	93.87%
Protein Sequence	100	90.55%
	200	90.30%
	300	90.56%
	400	90.31%
	500	90.56%
DNA Sequence	100	83.18%
	200	82.82%
	300	83.28%
	400	82.89%
	500	83.27%

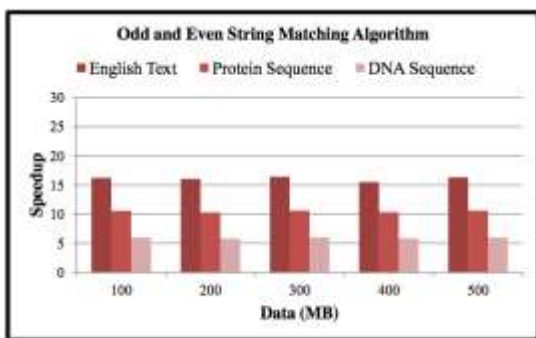

Figure 4. Parallel Speed-up of the GPU-Based Odd and Even Algorithm

VI CONCLUSION

In this paper, we have presented a GPU –based parallel Odd and Even Algorithm. The searching phase of the Odd and Even algorithm were redesign to suit the parallel nature of the GPU processor. Experimental results show that the parallel algorithm has a substantial speed up over the sequential version.

ACKNOWLEDGMENT

We would like to acknowledge the School of Computer Sciences, Universiti Sains Malaysia for the financial support in the publication of this paper.

REFERENCES

- Accreditation Commission for Programs in Hospitality Administration. (n.d.). *Handbook of accreditation*. Retrieved from <http://www.acphacahm.org/forms/acpha/acphahandbook04.pdf>
- Billson, C. J. (1892). The Easter hare. *Folklore*, 3, 441-466. Retrieved from <http://www.jstor.org>
- Bower, B. (2008, Feb. 9). Dawn of the city: Excavations prompt a revolution in thinking about the earliest cities. *Science News*, 173(6), 90-92. Retrieved from <http://www.sciencenewsmagazine.org/>
- Elementary school math instruction questionnaire results. Most significantly improved schools.* (n.d.). Retrieved from http://www.sharingsuccess.org/code/highperf/2002-03/es_math/msi/index.htm
- Fuchs, D., Fuchs, L. S., Al Otaiba, S., Thompson, A., Yen, L., McMaster, K. N., Yang, N. J. (2001). K-PALS: Helping kindergartners with reading readiness: Teachers and researchers in partnerships. *Teaching Exceptional Children*, 33(4), 76-80. Retrieved from <http://www.cec.sped.org/content/navigationmenu/publications2/teachingexceptionalchildren/>
- Goyen, A. (2007, February 22). Downtown Marquette dog sled races [Video file]. Retrieved from <http://www.youtube.com/watch?v=gW3CNCGGgTY>
- Hartley, J. T., Harker J. O., & Walsh, D. A. (1980). Contemporary issues and new directions in adult development of learning and memory. In L. W. Poon (Ed.), *Aging in the 1980s: Psychological issues* (pp. 239-252). Washington, DC: American Psychological Association.
- Herculano-Houzel, S., Collins, C. E., Wong, P., Kaas, J. H., & Lent, R. (2008). The basic nonuniformity of the cerebral cortex. *Proceedings of the National Academy of Sciences* 705, 12593-12598. doi: 1 0.1 073/pnas.08054171 05
- Hipp, E. (2000). *Understanding the human volcano: What teens can do about violence* [Monograph]. Retrieved from <http://www.eric.ed.gov/>
- Inness, S. A. (Ed.). (1998). *Delinquents and debutantes: Twentieth-century American girls' cultures*. New York, NY: New York University Press.
- Katz, I., Gabayan, K., & Aghajan, H. (2007). A multi-touch surface using multiple cameras. In J. Blanc-Talon, W. Philips, D. Popescu, & P. Scheunders (Eds.), *Lecture Notes in Computer Science: Vol. 4678. Advanced Concepts for Intelligent Vision Systems* (pp. 97-108). Berlin, Germany: Springer-Verlag. doi:10.1007/978-3-540-74607-2_9
- Langdon, S. W., & Preble, W. (2008). The relationship between levels of perceived respect and bullying in 5th through 12th graders. *Adolescence*, 43, 485-503. Retrieved from <http://find.galegroup.com>
- Larson, G. W., Ellis, D. C., & Rivers, P. C. (1984). *Essentials of chemical dependency counseling*. New York, NY: Columbia University Press.
- Lemay, L. (1997). *Teach yourself web publishing with HTML 4 in a week* (4th ed.). Indianapolis, IN: Sams.net.
- Limb, G. E., & Hodge, D. R. (2008). Developing spiritual competency with Native Americans: Promoting wellness through balance and harmony. *Families in society*, 89, 615-622. doi:10.1606/1044-3894.3816
- Lopez, J. (2005). *Characteristics of selected multilingual education programs from around the world: A review of the literature* (Unpublished master's thesis). Dominican University of California, Retrieved from ERIC database. (ED491402)

- Moriarty, L. J., & Carter, D. L. (Eds.). (1998). *Criminal justice technology in the 21st century*. Springfield, IL: Charles C. Thomas.
- Russo, C. A., & Jiang, H. J. (2006). *Hospital stays among patients with diabetes, 2004* (Statistical Brief #17). Retrieved from Agency for Healthcare Research & Quality website: <http://www.hcup-us.ahrq.gov/reports/statbriefs/sb17.jsp>
- Shaw, K., O'Rourke, P., Del Mar, C., & Kenardy, J. (2005). Psychological interventions for overweight or obesity. *The Cochrane Database of Systematic Reviews*, (2). doi:10.1002/14651858.CD003818.pub2
- Simon, C. E. (1995). *Information retrieval techniques: The differences in cognitive strategies and search behaviors among graduate students in an academic library* (Doctoral dissertation, Wayne State University). Retrieved from <http://www.eric.ed.gov/>
- Symonds, P. M. (1958). Human drives. In C. L. Stacey & M. DeMartino (Eds.), *Understanding human motivation* (pp. 11-22). doi:10.1037/11305-002
- U.S. Department of the Interior, National Park Service. (2004). *Pictured rocks national lakeshore, Michigan final general management plan, wilderness study, environmental impact statement*. Washington, DC: Author.
- Wilens, T. E., & Biederman, J. (2006). Alcohol, drugs, and attention-deficit/hyperactivity disorder: A model for the study of addictions in youth. *Journal of Psychopharmacology*, 20, 580-588. doi:10.1177/0269881105058776

Knowledge Sharing Factors Among EIS Students In a Private University

Chuleekorn Nuansomsri, and Suttisak Jantavongso

Rangsit University, Thailand, {chuleekorn.n; suttisak.j}@rsu.ac.th

ABSTRACT

Knowledge Sharing (KS) plays a significant role in knowledge creation for students, especially at a territory level. For this reason, this study aims to explore the sharing of knowledge factors among undergraduate students in a Thai private university. 50 students from Bachelor of Science Program in Enterprise Information Systems (EIS) were participated. The data collection took place in February and March 2016. This study was classified as non-experimental, quantitative research using a survey approach. Descriptive statistics, inferential statistics, and correlation statistics were employed as the data analysis methods. The findings revealed that 'Perceived Usefulness', 'Technological', 'Individual', 'Classroom', and 'Intention to Share' factors were statistically significant. Despite these results, 'Organizational' factor had no influence on sharing of knowledge among these group of students.

Keywords: knowledge sharing, information sharing, classroom, multiple regression.

I INTRODUCTION

Not only does Knowledge Sharing (KS) plays an extremely important role in the economic development of most organizations (Riege, 2005), but also an essential component of effective learning at the higher education level (Keong & Subhi, 2015; Majid & Yuen, 2006). While there were many prior studies on factors associated with KS in an organizational and a business context, a limit number of studies in an educational context has been identified (Wangpipatwong, 2009). Furthermore, KS is an importance element for intellectual discourses. It is also a demanding task that requires time and effort from students (Ghadirian, Ayub, Silong, Bakar, & Zadeh, 2014). Therefore, identifying factors that impact sharing of knowledge among students in learning communities is a critical task.

A. Purpose

The main objective of this study is to investigate factors associating with sharing of knowledge among undergraduate students in a classroom context within a private university in Thailand.

II LITERATURE REVIEW

A. Information and Knowledge

Whereas, the literature review by the authors suggested that information and knowledge are similar in many aspects, differences do exist (Al-Naheyman, 2013; Majid & Yuen, 2006). For example, Al-Naheyman (2013) had defined knowledge as information that has value and is part of a hierarchy of data, information, knowledge, and wisdom. In contrast to Al-Naheyman, Ghadirian et al. (2014) had defined information as a message which can be unidirectional and unrequested; and knowledge is interpreted information by a one's experiences and insights within a context and contains an 'element of reciprocity'.

B. Knowledge Sharing

Knowledge Sharing or KS is an element of Knowledge Management (KM) and an important factor for intellectual discourses. In addition, KS is also one of a critical step in Knowledge Acquisition (KA). Ghadirian et al. (2014) believed in the significance and value of sharing of knowledge among students. Ghadirian et al. (2014) expected students in the learning communities to be responsible of their education proactively by 'learning with both individual responsibility and communal sharing'. Moreover, the main challenge in both online and traditional learning is to encourage KS through social interaction in various forms. Hence, KS is viewed as a social phenomenon related to interpersonal relationships and social interactions. While communities provide setting for participation and presence in the discussion, students share knowledge and negotiate what they mean to one another (Ghadirian et al., 2014). Accordingly, KS has an ability to improve students' learning process and should be influenced by students' willingness to engage in the process. Similarly, Wangpipatwong (2009) also believed that KS is the process where individuals mutually exchange their knowledge and jointly create new knowledge. Thus, increasing KS would provide a positive effect on one's performance. However, students do not always exchange their knowledge.

C. Classroom Context

At the first instance, the meaning of classroom context may appears to be self-explanatory. According to Turner & Meye (2000), classroom

context can be defined as the beliefs, goals, values, perceptions, behaviors, classroom management, social relations, physical space, and social-emotional and evaluative climates that contribute to the students' understanding of the classroom. However, the authors believe that the influences of the teacher, other students, content area, and instructional activities on learning, teaching, and motivation also play an important role of KS.

III CONCEPTUAL MODEL

The aim of this stage is to conceptualize a model for sharing of knowledge factors. It involves the formulation of study objective and review of the literature on relevant research domains. This approach also encompasses an item generation approach as adopted by Jantavongso (2007) which also employed a thorough review of literature to develop the theoretical definition of factor under examination. Twenty-one items associated to knowledge sharing have been categorized into six factors: (I_n) Individual, (C_n) Classroom, (T_n) Technological, (IS_n) Intention to Share Knowledge, (P_n) Perceived Usefulness, and (O_n) Organizational, as shown in Table 1.

Table 1. Mapping Knowledge Sharing Factors

Authors	Knowledge Sharing Factors					
	Individual	Classroom	Technological	Intention to share	Perceived usefulness	Organizational
Majid & Yuen (2006)	x					
Wangpipatwong (2009)	x	x	x			
Zamiri & Baqutayan (2012)				x	x	
Yogeesha & Gopalakrishna (2013)	x	x	x			
Al-Naheyman (2013)	x					
Usman & Oyefolahan (2014)	x		x			x
Khosravi, Ahmad, & Sedera (2014)	x		x			x
Chen, Chen, & Kinshuk (2009)	x	x	x	x		

A. Individual Factors

Individual factors refer to three items such as (I₁) Communication Skill, (I₂) Ability, and (I₃) Willingness (Al-Naheyman, 2013; Chen et al., 2009; Majid & Yuen, 2006; Usman & Oyefolahan, 2014; Wangpipatwong, 2009; Yogeesha & Gopalakrishna, 2013).

B. Classroom Factors

Classroom factors refer to three items as follows: (C₁) Final Grade, (C₂) Classmate, and (C₃) Degree of Competition (Chen et al., 2009; Wangpipatwong, 2009; Yogeesha & Gopalakrishna, 2013).

C. Technological Factors

Technological factors refer to six items of Technology Availability (T₁) Tool, (T₂) the Internet, and (T₃) Communication Channel and Technology Support (T₄) Convenience, (T₅) Relevant, and (T₆) Contact (Chen et al., 2009; Khosravi et al., 2014; Usman & Oyefolahan, 2014; Wangpipatwong, 2009; Yogeesha & Gopalakrishna, 2013).

D. Intention to Share Knowledge

Intention to Share Knowledge refers to three items as follows: (IS₁) Share Course Materials, (IS₂) Discuss New Ideas, and (IS₃) Acquire Knowledge (Chen et al., 2009; Zamiri & Baqutayan, 2012).

E. Perceived Usefulness Factors

Perceived Usefulness factors are three items as follows: (P₁) Self Satisfaction, (P₂) Idea and Knowledge Generation, and (P₃) Self-Improvement (Chen et al., 2009; Zamiri & Baqutayan, 2012).

F. Organizational Factors

Organizational factors consist of three items as follow: (O₁) Instructor and Supervision, (O₂) Workgroup, and (O₃) Knowledge Culture (Khosravi et al., 2014; Usman & Oyefolahan, 2014).

These six factors identified through this process provide the insight for this study as shown Figure 1.

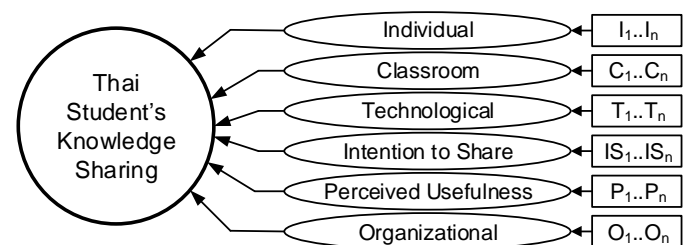

Figure 1. Factors for knowledge sharing

IV RESEARCH METHODOLOGY

This section describes the methodology used in this study. This study can be classified as non-experimental, quantitative research using a survey approach. The questionnaire technique was selected amongst all other survey methods to collect data in this study because it allows the participants to response freely, ensures anonymity in their convenience time and location. Furthermore, a survey approach is the most frequently used empirical research method in Information

Technology (IT) research (Shanks, Arnott, & Rouse, 1993).

A. Population and Data Collection

The target population was all of the students under Bachelor of Science Program in Enterprise Information Systems (EIS) in a private universities in Thailand (60 Students in total). Participants were notified in person during their classes and social network. The data was collected over a period of four weeks, from February until end of March 2016.

B. Instrument

The instrument consists of two main sections to obtain the responses from the participants. The first section used to collect the demographic information where the later section was to gather the opinions with the Likert-type questions. Likert-type items allow participants to indicate their responses by selecting statements on a continuum, from strongly not agreeing to strongly agreeing. An advantage of this type of item is that points can be assigned to the various responses and measures of central tendency variability, correlation, and other standard statistical measures can be calculated if required. In this study, only the five point Likert-type scale was used. It consists of the following numerical codes: 1 = strongly not agreed, 2 = not agreed, 3 = neutral, 4 = agreed, and 5 = strongly agreed.

Prior to this, the questions used in the questionnaires were first developed in English. However, as English is not the official language in Thailand, some participants may not be able to fully understand questions. The questions were presented in both Thai and English to avoid miscommunication and misinterpretation.

The instrument was evaluated by three experts using the Index of Item Objective Congruence (IOC) to rate individual items on the degree to which they do or do not measure specific objectives. Each expert evaluates each item by giving the item a rating of 1 (for clearly measuring), -1 (clearly not measuring), or 0 (degree to which it measures the content area is unclear) for each objectives. Item rates below 0.5 were not included (R. Turner, Mulvenon, Thomas, & Balkin, 2002)

C. Data Analysis

Three statistical data analysis methods were employed namely, descriptive statistics, inferential statistics, and correlation statistics. The descriptive statistical techniques were used to describe the sample in terms of frequencies, means, and standard deviations. Their use was to allow the researchers to characterize the population used in the study.

The inferential statistical techniques deal with F statistic, to assess the overall statistical significance of the model.

The correlation statistical techniques employed in this study is multiple regression analysis. The multiple regression analysis was performed to investigate the strength of associations between factors and to identify the relationship between the dependent variable (Knowledge Sharing: KS) and the independent variables (factors).

In addition, 'Path Analysis' was also employed in this study to examine relationships between important factors identified by the multiple regression analysis.

V RESEARCH FINDINGS

This section presents the details of the participants

A. Characteristics of the Participants

Fifty students had participated in this survey. These students were from Years 1 to 3 under Bachelor of Science Program in EIS in a private university in Thailand. Table 2 presents the details finding of the participants' demographic.

Table 2. General Characteristics of the Participants

	Frequency	Percentage
Gender		
Male	24	48
Female	26	52
Year Level		
Freshman	13	26
Sophomore	22	44
Junior	15	30
Senior	NA	NA
GPA		
< 2.00	2	4
2.01 – 2.50	9	18
2.51 – 3.00	14	28
> 3.00	25	50
Total	50	100

Moreover, Cronbach's Alpha (also referred to as coefficient alpha or α) was used in this study to measure internal consistency. According to George and Mallery (2003), there is no set interpretation as to what is an acceptable α value, however, a general rule of thumb should be greater than 0.7. Table 3 presents the results of analysis of internal consistency for 50 data. The analysis provided α values that met the recommended acceptable α value with the

exception of Technological. Despite this, the α value of Technological was almost 0.688 which is considered as an acceptable value following the study by Wangpipatwong (2009).

Table 3. Analysis of Internal Consistency

Knowledge Sharing Factors	Number of Items	Chronbach's alpha (α)
Individual	3	0.785
Classroom	3	0.720
Technological	6	0.688
Intention to share	3	0.861
Perceived usefulness	3	0.938
Organization	3	0.821

When the data collection process was completed, next the question's average from all the factors was carefully calculated and the results from Pearson Correlation Test are as follows:

Table 4. Analysis of Correlations

	Knowledge Sharing	Individual	Classroom	Technological	Intention To Share	Perceived Usefulness	Organization
Knowledge Sharing	1	.133	.293*	.259	.342*	.409*	.373
Individual		1	.045	.079	.018	.000	.424
Classroom			1	.117	.193	.283	.347
Technological				1	.193	.173	.188
Intention To Share					1	.128	.199
Perceived Usefulness						1	.595
Organization							1

*. Correlation is significant at the 0.05 level (2-tailed).
 **. Correlation is significant at the 0.01 level (2-tailed).

Table 5. Results of Multiple Regression Analysis

Model 1	Unstandardized Coefficients		Standardized Coefficients	Sig.
	B	Std. Error		
(Constant)	1.934	.777		.017
Individual	.044	.116		.000
Classroom	.011	.110	.013	.000
Technological	.056	.153	.057	.003
Intention To Share	-.005	.146	-.006	.000
Perceived Usefulness	.639	.143	.697	.000

Organization	-.058	.105	-.067	.058
--------------	-------	------	-------	------

Note. $R^2 = 0.455$

Where Knowledge Sharing = dependent variable; and 1 = strongly not influenced, 2= not influenced, 3 = neutral, 4 = influenced, 5 = strongly influenced on a five point Likert-type scale.

The model explained 45.5% of the total variance in the sharing rate of the knowledge by using six factors. Based on the recommendation by Pallant (2005), this model is considered to be an appropriate multiple regression model.

The model also achieved statistical significance. The ANOVA table (Table 6) indicated that the model was significant [F(1, 49) = 5.557, Sig. = .000].

Table 6. Results of Analysis of Variance (ANOVA)

Model	Sum of Squares	df	Mean Square	F	Sig.
1 Regression	7.951	6	1.325	5.557	.000
Residual	9.539	40	.238		
Total	17.489	46			

Pallant (2005) recommend the use of the beta values (beta) under Standardised Coefficients to compare the contribution of each factor (independent variable) (Table 5). The largest beta coefficient (ignoring any negative signs) indicates that the factor makes the strongest unique contribution to explaining the dependent variable, while keeping other factors unchanged. The next task is to test the unique contributions of each factor to the prediction of the dependent variable (the Sig. value is less than .05).

Examining the beta values in Table 5, reveals that five factors are statistically significant. In order of importance they are: 'Perceived Usefulness', 'Technological', 'Individual', 'Classroom', and 'Intention to Share'. The relationships between 'Organizational' and KS was not statistically significant.

B. Path Analysis

A Path model was constructed to examine the relationship between the knowledge sharing and the five factors. Figure 2 depicts a path of a multiple regression analysis to predict the sharing of knowledge from the five factors.

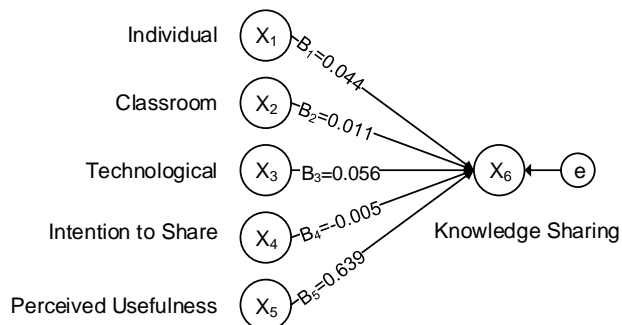

Figure 2. Path model for knowledge sharing

C. Regression Equation

The multiple regression analysis using SPSS generated the B values and the constant as presented in Table 5. From these numbers, a new equation can be generated to determine the predicted value for the sharing of knowledge:

$$X_6 = 1.934 + 0.044(X_1) + 0.011(X_2) + 0.056(X_3) - 0.005(X_4) + 0.639(X_5)$$

Where:

X_6 = Knowledge Sharing

X_1 = Individual

X_2 = Classroom

X_3 = Technological

X_4 = Intention to Share

X_5 = Perceived Usefulness

An analysis of the results indicates the unstandardized partial regression coefficient or slope that describes the linear relationship between the sharing of knowledge and one of five factors with all other factors held constant, as follows:

Each additional degree of Individual (X_1), Classroom (X_2), Technological (X_3), and Perceived Usefulness (X_5) increases the Knowledge Sharing (X_6) by 0.044, 0.011, 0.056, and 0.639 degree respectively.

Whereas, each additional degree of Intention to Share (X_4) decreases the Knowledge Sharing (X_6) by 0.005 degree.

D. Interpretation of Each of the Factors with a Negative Sign

The possible explanation for why each additional degree of the 'Intention to Share' decreases the 'Knowledge Sharing (KS)' is that there is an unwilling on the part of the participants as to share knowledge such as course materials and new ideas with their fellow participants. The participants are

reluctant to share their acquired knowledge with their fellow participants.

VI CONCLUSION

Knowledge Sharing or KS plays an important role in the educational setting of the students, especially for the higher education sector in Thailand. Sharing of knowledge offers Thai students the potential to opportunities to enhance their learning. Twenty-one items in six factors were identified through (1) the objective, (2) the review of the literature on relevant research domains, and (3) the item generation approach in developing the proposed factors. 50 students were participated during February to March 2016. The findings identified that 'Perceived Usefulness' is the most important factor believed by Thai students follow by 'Technological', 'Individual', 'Classroom', and 'Intention to Share' factors, respectively. Thus, the results suggested that to encourage knowledge sharing among Thai undergraduate students in a private university, the 'Perceived Usefulness' factor should be emphasized.

VII LIMITATIONS AND SUGGESTIONS FOR FUTURE RESEARCH

As in all research, the research presented here does have its limitations and this section considers some of these together with a number of possible directions for further research. The first, and most obvious, limitation concerns the issue of bias and representation. In this study, the survey population used may not be representative of all Thai students in a private university. One area of possible future research would be to extend the survey to other Thai universities who were not surveyed. Multiple regression was the major data analysis technique used in this study.

However, the multiple regression technique is restricted to the analysis of one single relationship at a time (Cheong & Leckenby, 2004). Other techniques exist, such as Structural Equation Modelling (SEM) technique, which may be used to examine a series of interrelated dependence relationships simultaneously and it would be an interesting area of future work to examine an analysis based on such approaches

ACKNOWLEDGMENT

The authors would like express our thanks to Ms. Sumana Kasemsawasdi, Dr. Somboon Anekritmongkol, Ms. Saritkan Sithikrai Wong, and the students of Bachelor of Science Program in Enterprise Information Systems, Rangsit University, Thailand for their supports and contributions.

REFERENCES

- Al-Naheyay, C. (2013). *Knowledge sharing practices among the graduates in Dhaka University*. (Master's thesis), University of Dhaka, Dhaka, Bangladesh.

- Chen, I. Y., Chen, N.-S., & Kinshuk. (2009). Examining the factors influencing participants' knowledge sharing behavior in virtual learning communities. *Journal of Educational Technology & Society*, 12(1), 134.
- Cheong, Y., & Leckenby, J. (2004). SEM versus Regression for modeling of attitude toward the internet retailer. Paper presented at the Annual Conference American Academy of Advertising, Baton Rouge, United States.
- George, D., & Mallery, P. (2003). *SPSS for Windows step by step: A simple guide and reference 11.0 update*. Boston: Allyn and Bacon.
- Ghadirian, H., Ayub, A. F. M., Silong, A. D., Bakar, K. B. A., & Zadeh, A. M. H. (2014). Knowledge sharing behaviour among students in learning environments: A review of literature. *Asian Social Science*, 10(4), 38-45.
- Jantavongso, S. (2007). *Facilitating e-business implementation among Thai SMEs*. (Doctor of Philosophy PhD), Monash University, Clayton.
- Keong, Y. C., & Subhi, S. N. (2015). The role of knowledge sharing in the learning process among Iraqi EFL postgraduate students in UKM. *International Journal of Education and Research*, 3(12), 185-198.
- Khosravi, A., Ahmad, M. N., & Sedera, D. (2014). Antecedent factors of Knowledge sharing in research supervision. Paper presented at the 19th Pacific Asia Conference on Information Systems, Chengdu, China.
- Majid, S., & Yuen, T. J. (2006). Information and knowledge sharing by undergraduate students in Singapore. Paper presented at the 17th IRMA International Conference, Washington, D.C., United States.
- Pallant, J. (2005). *SPSS survival manual: A step by step guide to data analysis using SPSS for Windows (Version 12)*. Crows Nest: Allen & Unwin.
- Riege, A. (2005). Three-dozen knowledge-sharing barriers managers must consider. *Journal of knowledge management*, 9(3), 18-35.
- Shanks, G., Arnott, D., & Rouse, A. (1993). *A review of approaches to research and scholarship in information systems*. Clayton: Department of Information Systems, Faculty of Computing and Information Technology, Monash University.
- Turner, J. C., & Meyer, D. K. (2000). Studying and understanding the instructional contexts of classrooms: Using our past to forge our future. *Educational Psychologist*, 35(2), 69-85.
- Turner, R., Mulvenon, S., Thomas, S., & Balkin, R. (2002). Computing indices of item congruence for test development validity assessments. Paper presented at the 27th Annual SAS Users' Group International Conference, Miami, United States.
- Usman, S. H., & Oyefolahan, O. (2014). Determinants of knowledge sharing using web technologies among students in higher education. *Journal of Knowledge Management, Economics and Information Technology*, 4(2), 1-22.
- Wangpipatwong, S. (2009). Factors influencing knowledge sharing among university students. Paper presented at the 17th International Conference on Computers in Education, Hong Kong.
- Yogeesha, H. C., & Gopalakrishna, S. G. (2013). Factors influencing knowledge sharing among undergraduate engineering students. *The International Journal Research Publications's Research Journal of Science and IT Management*, 2(5), 47-52.
- Zamiri, M., & Baqutayan, S. (2012). Exploring factors that influence knowledge sharing behavior via computer. *Journal of Emerging Trends in Computing and Information Sciences*, 3(4), 799-805.

Decision Making in Local Government: The Myth of Success Model of Information System

Mohd Zool Hilmie Mohamed Sawal^{1,2}, and Kamarudin Ngah²

¹Universiti Teknologi MARA (UiTM), Malaysia {zoolhilmie@ymail.com}

²Universiti Utara Malaysia, Malaysia

ABSTRACT

A good decision must be able to deliver a good result to the community and overcome the problem. Relating with local government it's reflecting their services serving to their community. Thus, the role of information system plays a major role in providing good data to the decision maker. In reality, some decision maker does not want to use or accept the information system. This paper proposed the conceptual model in understanding the acceptance of information system. Two models Delone & McLean Information System Success 2003 and Unified Theory of Acceptance and Use of Technology (UTAUT) are being discussed.

Keywords: Acceptance, information system, local authority, decision making.

I INTRODUCTION

Decision making can be a crucial progress when dealing with major problem. A good decision must be able to deliver a good result to the community and overcome the problem. Relating with local government it's reflecting their services serving to their community. The introduction of '1Malaysia Customer Service of Civil Service' (1Serve) has focused on transforming the quality of service and increasing customer satisfaction (National Blue Ocean Strategy, 2015), as well as the implementation of Star Rating System that established to assess local authority's level of performance. The Ninth Malaysia Plan 2006-2010 in Chapter 26 entitled "Efficient Public Service Delivery System" has emphasized on setting clear strategic directions to be in line with the national agenda. This is able to grading local authority's level of performance measurement and service delivery system.

II INFORMATION SYSTEM

A good decision making process should involve all level in organization including local authority. To support good decision making process, Information system plays a major role. In order to capture and process the relevant data needed by decision maker.

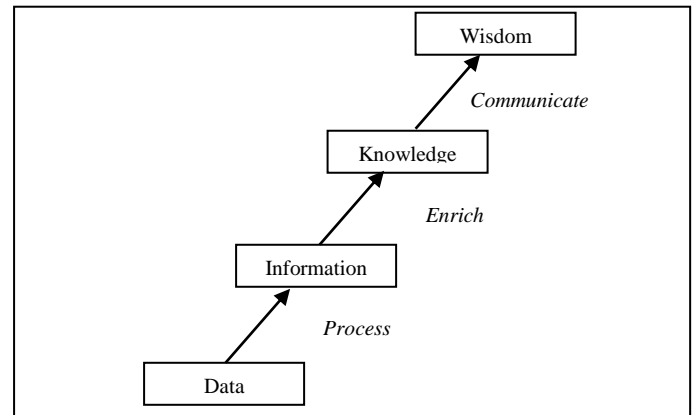

Figure.1. The information spectrum (Lowrey, 1996)

From data that contain the raw fact of something such as an event that occur or fact and figure from sale then manipulate or process into information, and evolve to knowledge and wisdom. The characteristic of value information are accessible, accurate, complete, economical, flexible, relevant, reliable, secure, simple, timely and verifiable (Figure 1).

In Malaysia context, government has spent a lot of budget to improve IT infrastructures such as the implementation of Malaysia Super Corridor (MCS) that contain seven flagships, namely Generic Office Environment (GOE), Electronic Procurement (EP), Project Monitoring System (PMS), E-Syariah, Electronic Labor Exchange (ELX), Human Resource Management Information System (HRMIS) and Electronic Service Delivery under the 7th Malaysia Development Plan. Furthermore the implementation of Malaysia National Key Economic Areas (NKEAs) emphasizes one key area

The Communications Content and Infrastructure (CCI) sector spans a wide ecosystem covering content, network applications, services and devices. In 2009, the sector contributed RM22 billion of Gross National Income (GNI) from telecommunications, TV, broadcasting, post and courier

(ETP Annual Report 2011)

The initiative shows how important to implement information system especially in delivering good service to the community by making good decision. It

also can build up a good relationship between local government and its community (Zakaria, Ngah, Hussin, Noordin, & Mohamed Sawal, 2011). The ability to measure the quality of a service is a prerequisite to obtain a high quality level (Lee & Kim, 2014) because community expecting a better services from local government.

III ISSUES

Decision making is one of the important aspects in an organization, It is very much dealings with how decision is made, to what standard, what cost and for whom. Decision making is a process to choose the best solution that meet objective or goals (Ngah, Zakaria, Noordin, & Mustafa, 2015). Important elements in decision making process are the flow of information and the creating of new knowledge or ideas (Ngah, Zakaria, Hussin, Noordin, Mustafa, & Mohamed Sawal, 2012) Be aware of the importance of information flow and the need to clarify and re-clarify what is happening (NLC, 2006).

The existence of information system indirectly helps to provide information when needed. However the acceptance is low. Doubtfully of the acceptance toward its effectiveness is there among people (Holden, Norris & Flether, 2003). On the other hand, information system help promote more efficient and effective government, such as facilitate more accessible government services, help public access to information, and make government more accountable to citizens (Sarrayih & Sriram, 2015). For instance Electronic Information Sharing (EIS) among Local Government Authorities are important for sharing information and knowledge which contain tacit and explicit knowledge in the form of formal documents, information relationships, messages, emails, etc (Bigdeli, Kamal & Cesare, 2013). The low acceptance may tend toward accessibility, efficiency, effectiveness, accountability and transparency of the government services (Danila & Abdullah, 2014). One of the key problems for the occasional use of E-Government services is the lack of awareness of the potential factors which help users to realize and accept the service (Chelliah, Thurasamy, Alzahrani, Alfarraj, & Alalwan, 2016). Thus inflict to low adoption and usage rates by citizens and also different adoption and usage rates between municipalities (Seo, & Bernsen, 2016)

IV MODEL DISCUSSION

This concept paper discusses the conceptual model in understanding the acceptance of information system.

This paper based on two models namely; Delone & McLean Information System Success, 2003 and UTAUT: Unified Theory of Acceptance and Use of Technology.

Delone and Mclean developed Information Success Model in 1992. This model consist six interrelated factors that is System Quality, Information Quality, Use, User Satisfaction, Individual Impact and Organizational Impact. Later they update their model; Delone & McLean Information System Success Model 2003 as shown in Figure 2 (Deleon & Mclean, 2003). This update model consists of three main factors. The model explains that the information quality, service quality and system quality are three main factors that influence susceptibility and satisfaction, and the interaction of these two factors (intention to use & user satisfaction) will benefit the whole system.

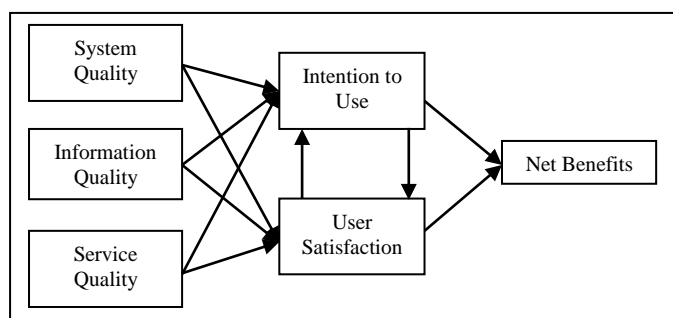

Figure 2. Delone & Mclean Information System Success Model 2003

This model is widely use nowadays. Wang and Liao (2008) conducted study on e-government system to evaluate the effectiveness of this system because citizens have demanded more and better services. Deleon and Mclean Model also being used to study citizens' acceptance and adoption of e-government services in the context of developing countries. This study explores the factors encouraging and barriers for citizen in the context of e-government services (Akram & Malik, 2012). There also a study done in 2012 by applying two models Technology Acceptance Model (TAM) and DeLone & McLean information success model 2003 (Zaied, 2012). This study tries to develop a new model to assess the critical success factors affecting information systems in public sector in Egypt and demonstrate the new model to give support to the decision makers in evaluating and developing a good information system.

UTAUT model originally from TAM model by Venkatesh. UTAUT Model (Venkatesh, Morris, Davis & Davis, 2003) consist four determinants of intentions or usage that play a direct role of user acceptance or usage behaviours: performance

expectancy, efforts expectancy, social influence and facilitating conditions.

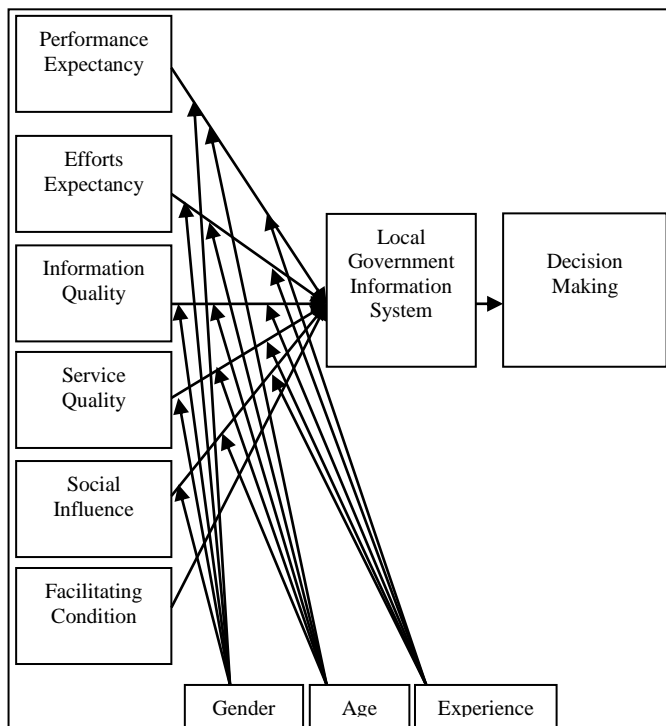

Figure 3. Proposed Conceptual Model

Figure 3 shows the proposed Conceptual Model. Two extended variables added in this framework (Information Quality and Service Quality). Moderated variable such as gender, age, and experience is being added to find any possible reason that related to the variable.

V CONCEPTUAL MODEL THEMES

Based on Figure 3, six themes are being derived for this study:

- i. Performance Expectancy of local authority information system in providing information for decision making
- ii. Efforts Expectancy of local authority information system in providing information for decision making
- iii. Information Quality of local authority information system in providing information for decision
- iv. Service Quality of local authority information system in providing information for decision making
- v. Social Influence to use local authority information system in providing information for decision making
- vi. Facilitating Condition to use local authority information system in providing information for decision making.

VI CONCLUSIONS

This conceptual model hopefully can help in understanding the needs and acceptance of local authority and community residents towards information system providing by their local authority.

The conceptual model also can provide better understanding on the overall process of decision-making at the local government level especially relate with the needs of information.

ACKNOWLEDGMENTS

This work is part of postgraduate study undergone by the author under development management areas, School of Government, College of Law, Government and International Studies, Universiti Utara Malaysia.

Author also would like to thanks the management of Universiti Teknologi MARA (UiTM) for their support.

REFERENCES

- Akram, M. S., & Malik, A. (2012). Evaluating citizens' readiness to embrace e-government services. Proceedings of the 13th Annual International Conference on Digital Government Research (pp. 58-67). University of Maryland, College Park, MD: ACM.
- Bigdeli, A. Z., Kamal, M. M., & Cesare, S. D. (2013). Electronic information sharing in local government authorities: Factors influencing the decision-making process. *International Journal of Information Management*, 33(5), 816-830. doi:10.1016/j.ijinfomgt.2013.05.008
- Chelliah, P. P., Thurasamy, R., Alzahrani, A. I., Alfarraj, O., & Alalwan, N. (2016). E-Government service delivery by a local government agency: The case of E-Licensing. *Telematics and Informatics*, 33(4), 925-935. doi:10.1016/j.tele.2016.02.003
- Danila, R., & Abdullah, A. (2014). User's Satisfaction on E-government Services: An Integrated Model. *Procedia - Social and Behavioral Sciences*, 164, 575-582. <http://dx.doi.org/10.1016/j.sbspro.2014.11.148>
- Deleon, W. H., & Mclean, E. R. (2003). The DeLone and McLean Model of Information Systems Success: A Ten-Year Update. *Journal of Management Information Systems*, 19 (4), 9-30.
- H. Zaied, A. N. (2012). An Integrated Success Model for Evaluating Information System in Public Sectors. *Journal of Emerging Trends in Computing and Information Sciences*, 3 (6), 814-825.
- Holden, S. H., Norris, D. F., & Fletcher, P. D. (2003). Electronic Government at the Local Level: Progress to Date and Future Issues. *Public Performance & Management Review*, 26(4), 325-344. doi:10.1177/1530957603026004002
- Lee, H., Kim, C., 2014. Benchmarking of service quality with data envelopment analysis. *Expert Syst. Appl.* 41, 3761-3768.
- National Blue Ocean Strategy. (2015, May 18). Serving up quality service. *New Straits Times*, p. 9.
- National League of Cities (NLC), 2006, Guide to Successful Local Government Collaboration in America's Regions, A Report from NLC's CityFutures Program, Washington, D.C. http://www.lincolninst.edu/subcenters/regional-collaboration/pubs/RC_for_Local_Govts_2006.pdf
- Ngah, K., Zakaria, Z., Noordin, N., & Mustafa, J. (2015). Decision-Making Model at Local Government Level: A New Proposed for Majlis Perbandaran Kuantan. *Journal of Economics and Sustainable Development*, 6(1), 1-13.
- Ngah, K., Zakaria, Z., Hj Hussin, Z., Noordin, N., Mustafa, J., & Mohamed Sawal, M. (2012). A Proposed Model in Fundamental of

- Decision Making Process at Local Government Level. *Asian Social Science*, 8(8), 96-102.
- Performance Management & Delivery Unit (Pemandu). (2012). ETP Annual Report 2011 (p. 152, Rep.). Putrajaya: Prime Minister's Department
- Ross Lowrey, (1996) "Relating information and value disciplines", *Information Management & Computer Security*, Vol. 4 : 3, pp.30 – 35
- Sarrayrih, M. A., Sriram, B. 2015. Major challenges in developing a successful e-government: A review on the Sultanate of Oman. *Journal of King Saud University - Computer and Information Sciences*, 27(2), 230-235.
- Seo, D., & Bernsen, M. (2016). Comparing attitudes toward e-government of non-users versus users in a rural and urban municipality. *Government Information Quarterly*. doi:10.1016/j.giq.2016.02.002
- Venkatesh, V., Morris, M. G., Davis, G. B., & Davis, F. D. (2003). User Acceptance of Information Technology: Toward a Unified View. *MIS Quarterly*, 27 (3), 425-478.
- Wang, Y.-S., & Liao, Y.-W. (2008). Assessing eGovernment systems success: A validation of the DeLone and McLean model of information systems success. *Government Information Quarterly*, 25, 717–733.
- Zakaria, Z., Ngah, K., Hussin, Z., Noordin, N., & Mohamed Sawal, M. (2011). Customer Satisfaction in Municipal Services: An Empirical Study in Majlis Perbandaran Sungai Petani (MPSPK). *International Proceedings of Economics Development and Research*, 6, 128-132.

Retaining Knowledge Worker through Motivation

Hway-Boon Ong, Lee-Lee Chong, and Kasuma Nurhazwani Mohd Hatta

Multimedia University, Malaysia {hbong@mmu.edu.my}

ABSTRACT

This study examines how knowledge workers could be retained to meet the demand of the local industry. A survey was carried in Iskandar Malaysia to gauge the knowledge workforce's views on what motivated them to continue working in Malaysia. A seven Likert-scale questionnaire was distributed to workers that had at least a first degree or higher diploma education from a local or foreign institution of higher education. Out of the 200 questionnaires distributed to employees of randomly selected companies identified in the ICT Blueprint for 2020 Iskandar Malaysia, 145 was complete and usable for analysis. Data collected were analysed using reliability test, factor analysis and multiple regression.

Keywords: knowledge workers, retain motivation.

I INTRODUCTION

Knowledge workers are worker who attained the relevant skills to meet the demand of the industry (MSC¹). It is a crucial factor of production that will boost economic development to greater heights. When Malaysia's knowledgeable workforce leaves Malaysia and contributes to the development of other foreign countries, Malaysia will not be able to achieve its aspiration of a high-income country.

Brain drain in Malaysia indicates that the growth of Malaysia's economy is dependent on its shrinking pool of talented and knowledgeable workforce. Although there is an increase in the number of overseas Malaysians returning, mainly due to family reasons, the numbers may not be significant enough as compared to those young, well-educated Malaysians leaving the country (Jauhar & Yusoff, 2011).

Malaysia is also becoming very dependent on foreign workers, of which, have little or no formal education (Mohamed, Ramendran, & Yacob, 2012), as compared to Malaysians emigrating. This imbalanced influx of blue-collar workers and outflow of knowledge workers will affect the productivity, growth and social economic imbalances of Malaysia.

This research is carried out to study how to retain knowledge workers by motivation, which in turn, reduces brain drain, raise economic growth, and even attracts global talent to Malaysia.

¹ MSC Malaysia is Malaysia's government ICT initiative designed to promote ICT and ICT related businesses.

II MOTIVATING KNOWLEDGE WORKER

Motivating knowledge workers require job redesign, competitive financial rewards, conducive environment, leadership management and an organizational structure that is devoid of undue bureaucracy and protocols (Muo, 2013). Earlier studies suggested that attracting knowledge workers (through attractive compensation packages, proactive recruitment and internal filling), has to be followed by retaining (through opportunities for growth, conducive working environment, transparent compensation awards) and then, motivating them (through effective communication, conducive working environment, compensation plan and opportunities for career advancement) (Horwitz, Heng, & Quazi, 2003). As such, more managers are requested to replace their existing management style with more current ones that can expand the capacity of their knowledge workers so that they can constantly utilize their knowledge in the workplace (Imafidon, 2009).

The company's management team has to also motivates its knowledge workers by providing them the necessary tools and environment they can perform at their best (Massaro, 2012). Workers are more likely to be retained in firms with a generally acceptable management style, pleasant work experience, adequate resources, flexible working environment, cooperative, friendly and caring colleagues, as well as the availability of opportunities to learn new skills and obtain promotion (George, 2015).

III EXPECTANCY THEORY

The expectancy theory explains an employee's motivation towards its job through expectancy, instrumentality and valence. Firstly, a knowledge worker's expectancy is its belief that his or her effort will yield the expected performance goal. In order for a motivated knowledge worker to put effort towards its task, he or she has to perceive that his or her effort will result in a certain level of performance, or that a certain level of performance is attainable. Usually, this is based on an individual's past experience, self-confidence and the perceived difficulty of the performance standard or goal.

Secondly, the instrumentality of a knowledge worker is his perception that a given performance level is related to a given outcome. A knowledge worker will perform at a certain level if he believes that the performance will lead to a certain level of result, such as a pay increase, promotion, recognition, or sense of accomplishment. A worker must know specifically

what behaviors are desired by their employers and understand that they are instrumental in achieving rewards (Chiang & Jang, 2008; Johnson, 2010).

Thirdly, valence is the expected satisfaction a knowledge worker receives from a particular outcome. The value that the knowledge worker places on an expected outcome or reward is directly related to who he is, his needs, goals, values and preferences (Chou & Pearson, 2012). For example, a person's satisfaction of a promotion may not be high if he is uncomfortable with work relocation and new environment. Valence deals with the worker's perception of reward and not the actual value of the reward (Holland, 2011).

IV METHODOLOGY

A survey was conducted in Iskandar, Johor to gather the knowledge workforce's motivation towards their job through expectancy, instrumentality and valence. A seven Likert-scale questionnaire was distributed to workers that had at least a first degree or higher diploma education from a local or foreign institution of higher education. Two hundred questionnaires were distributed to employees of randomly selected from companies identified in the ICT Blueprint for 2020 Iskandar Malaysia (IRDA, 2011) by drop and collect method. Out of the 200 questionnaires distributed, 145 was complete and usable for analysis. Data collected were analysed using reliability test, factor analysis and multiple regression analysis.

V FINDINGS

Approximately 69% of the respondents are female. Most of the respondents are aged between 21 to 40 years old (81.4%) and about 58% of the respondents earn between RM3,000 to RM8,000 per month. About 83% of the respondents holds a bachelor's degree. Details on the characteristics of respondents are presented in Table 1.

Table 1: Respondents' Demographic

Gender	Number (%)
Male	45 (31.0%)
Female	100 (69.0%)
Age	
Below 21	8 (5.5%)
21-40	118 (81.4%)
41-60	19 (13.1%)
Gross Monthly Income	
< RM3,000	51 (35.2%)
RM3,001 – RM8,000	84 (57.9%)
RM8,001 - RM13,000	7 (4.8%)
> RM13,000	3 (2.1%)
Education	
Bachelor's Degree/ Higher Diploma	120 (82.8%)
Master's Degree	14 (9.6%)
PhD/Professional	11 (7.6%)

The empirical findings of this study can be discussed in three folds. Firstly, the reduced set of variable collectively meets the necessary threshold of the Bartlett's test of nonzero correlation and the acceptable MSA value of more than 0.50. Hence, it is feasible to proceed to factor analysis. See Table 2 for details.

Table 2: KMO and Bartlett's Test

Kaiser-Meyer-Olkin Measure of Sampling Adequacy.	0.892
Bartlett's Test of Sphericity	Approx. Chi-Square 2453.05***

Note : ***(**) denotes 99% (95%) level of significance.

Secondly, the construct validity of scales is established by the principle of component analysis. Items with more than 50% loading of the rotated component matrix are accepted as items for each variable of the factor analysis. The Cronbach's Alpha reliability index is also employed to measure the internal consistency of scales.

Results indicate that instrumentality ($\alpha = 0.935$), expectancy ($\alpha = 0.899$) and valence ($\alpha = 0.872$) will motivate knowledge workers in Iskandar Malaysia. All factors met the acceptable reliability score of more than 0.7 (Nunnally, 1978). The cumulative rotated sum of squares loading was at a satisfactory level of 71.467%. See Table 3 for details.

Table 3: Knowledge Workers' Motivation

	Rotated Component Matrix	% of Variance
Instrumentality ($\alpha = 0.935$)		
Financial incentives motivates me	0.734	
Financial reward makes me strive harder	0.809	
I am financially inclined	0.715	
Acknowledgement motivates me	0.869	
Praises and congratulatory remarks motivates me	0.891	31.44
Positive feedback encourages me	0.837	8
Work recognition satisfies me	0.860	
Work recognition makes me strive harder	0.862	
Expectancy ($\alpha = 0.899$)		
I am able to learn something new in my work	0.581	
My career path in my company is clear	0.689	
There is career growth in my company	0.797	
My colleague(s) is(are) supportive	0.746	22.61
		7

The workplace has a positive environment	0.860	
Satisfactory financial reward	0.650	
I am appreciated in my workplace	0.668	
Valence ($\alpha = 0.872$)		
I participate in decision making in my company	0.815	
I feel the sense of autonomy in my work	0.793	
I am responsible for the decisions I made	0.750	17.40 2
I gain personal enhancement with the work I do	0.726	

Finally, the retained factors are regressed against the knowledge workers' opinion on job retention. The t-test result denotes that all independent variables are statistically significant in retaining knowledge workers at the 99% level of significance. The F-test result implies that all independent variables are statistically significant in retaining knowledge workers at 99% level of significance. The multiple regression reveals that retaining knowledge workers in Iskandar Malaysia are 81.2% significantly and positively affected by all three factors. See Table 4 for details.

Table 4: Summary of Multiple Regression Analysis

Independent Variables	Co-efficient ($\hat{\beta}_{it}$)	t-statistics
(Constant)	4.697	84.367***
Instrumentality	0.331	5.920***
Expectancy	0.807	14.447***
Valence	0.299	5.351***

$R^2=0.812$ and Adjusted $R^2=0.652$

Note : ***(**) denotes 99% (95%) level of significance.

VI CONCLUSION

Globalization has led to the fierce competition for skilled and knowledgeable labor which led to intense

labor mobility worldwide. Increased outflow of knowledge workers is usually at the expense of the host countries, especially when the host country is a developing country like Malaysia (Jauhar & Yusoff, 2011). Therefore, as long as knowledge workers are motivated with their job, employers will be able to retain them, at least locally.

ACKNOWLEDGMENT

This is part of a research project funded by the Ministry of Education, under the Fundamental Research Grant Scheme.

REFERENCES

- Chiang, C.-F., & Jang, S. (2008). An expectancy theory model for hotel employee motivation. *International Journal of Hospitality Management*, 27(2), 313–322. doi:10.1016/j.ijhm.2007.07.017
- Chou, S. Y., & Pearson, J. M. (2012). Organizational citizenship behaviour in IT professionals: an expectancy theory approach. *Management Research Review*, 35(12), 1170–1186. doi:10.1108/01409171211281282
- George, C. (2015). Retaining professional workers: what makes them stay? *Employee Relations*, 37(1), 102–121. doi:10.1108/ER-10-2013-0151
- Holland, D. V. (2011). Utility maximization? An expectancy view of entrepreneurial persistence. *Management Research Review*, 34(3), 337–352. doi:10.1108/01409171111116349
- IRDA. (2011). Information Communication Technology Blueprint 202 for Iskandar Malaysia. Retrieved from <http://www.iskandarmalaysia.com.my/pdf/blueprint/Information-Communication-Technology.pdf>
- Jauhar, J., & Yusoff, Y. M. (2011). Brain Drain : Propensity to Leave by Malaysian Professionals, 2(2), 119–123.
- Johnson, R. R. (2010). Making domestic violence arrests: a test of expectancy theory. *Policing: An International Journal of Police Strategies & Management*, 33(3), 531–547. doi:10.1108/13639511011066890
- Mohamed, R. K. M., Ramendran, C., & Yacob, P. (2012). The Impact of Employment of Foreign Workers : Local Employability and Trade Union Roles in Malaysia, 2(10), 530–542.
- Muo, I. (2013). Motivating & Managing Knowledge Workers: Evidences from Diverse Industries & Cultures. *Journal of Management and Sustainability*, 3(2), 119–132. doi:10.5539/jms.v3n2p119

A Study on Transforming the Knowledge in Design Learning Environment

Nur Aziemah Mohamad, Khairul Anwar Mohamed Khaidzir, and Roliana Ibrahim

Universiti Teknologi Malaysia, Malaysia, {aziemah.mohd@gmail.com}

ABSTRACT

Design learning is a paradigm where it is often being cultivated in the architectural domain. The paradigm itself is quite different from the other pedagogies. In design learning, the students need to undergo a design process to create their artefact in a certain period of time. The process itself consists of three distinct phases, which are ideation proposal, critique and iterate. The teaching and learning session in architectural design learning environment often focuses on the interactions and thus, producing communications in the studio class. During the design process, the interactions occurred can be categorised as human-artefact and human-human. While in the design process, there is a lot of knowledge in which can be expressed and applied towards the design artefact. The expression is so tacit that sometimes it is difficult for the students to transform and capture it into explicit knowledge. The knowledge transferred from the instructor to the students can act as a scaffold in creating the design artefact. Therefore, a virtual learning tool is proposed to investigate how efficient the technology can assist the transformation of tacit knowledge into explicit in design learning environment.

Keywords: Design learning, transform, tacit knowledge, explicit knowledge.

I INTRODUCTION

Mankind has done a lot of designing throughout the history. The design is often expressed together with the innovation created by the human being. Design is vast and applied in almost all of the domains that have existed in the world. It consists of multiple disciplines and the designers themselves need to have a lot of knowledge in expressing their skills while doing the design practice (Lim et al, 2011). However, architectural and fine arts are the most popular domains when it comes to design (Lawson 2005).

To learn on how to create a design formally, the information and knowledge can be gathered in a studio class. In the studio class session, the students need to undergo a process in creating their design artefact. The design process has three distinct phases, which are ideation proposal, critique and iteration (Brocato, 2009). Both of these phases, propose and

critique, will iterate throughout the design process until their design artefact can be considered as done. Thus, as the students go through the design process, there will be a lot of interactions going on between the students themselves and their instructor.

The interactions between instructor and students are essential during the design process and can be categorised into human-artefact and human-human interactions (Goldschmidt, 1995; Lawson, 2005). Most of the interactions occur during the critique phase in a design process. Every pedagogy existed is known for its implicitness. This is also applicable to design learning. The interaction between the instructor and students show that the knowledge from the instructor is being transferred to the students regarding on the ideation proposal. As the knowledge is transferred to the students, the transformation from the tacit knowledge of design to explicit must be captured by them.

In this paper, the sections will start with the introduction regarding the study. Secondly, a brief description on design learning environment. Followed by design as tacit knowledge and its knowledge transformation occurred during the process. The next section consists of a discussion regarding on the topic. Finally, a conclusion is done to deduce this paper.

II DESIGN LEARNING ENVIRONMENT

Design can be implemented in different domain but served as the same purposes. It consists of multiple disciplines and the designer needs to have a vast knowledge to express their skills in the design practice (Lim et al, 2011). In addition, design itself is a thinking model in which it will lead to the meaning of productive design and sense of productivity (Goldschmidt, 1995; Wertheimer, 1945).

Learning emphasizes on individual intellectual that leads to the development of ideas (Bouton, 2007). Design learning is an environment where it is adopted for the architectural students in a studio class session. Each author has their own terms and definitions in describing the design learning. Generally, it consists of a process where it has a distinct value and quality. The design process contained several phases such as propose, critique and iterate (Brocato, 2009).

Design may contain a recurring pattern from past experience or knowledge that the designers may not

have started it from scratch (Borchers, 2001). Thus, in a design process, the first phase would be the ideation proposal. This is the phase where the students need to propose their ideas to their instructor. Then, the instructor will criticise the proposed idea by the students. The criticism made is constructive and will be a scaffold towards the student's design. Both of these phases will iterate until the design artefact can be considered as done.

The critique phase in the design cycle makes it stand out from the other pedagogies. To transfer the knowledge of design from the instructor to students, this scenario can be found in the critique phase. In the critique phase, most of the interactions occur to get the best design. Interactions are essential in order to pass the knowledge from the instructor to students and this is proven by Lawson (2005) as he defined and divided the design process into assimilation, general study, development and communication.

A. Interactions in Design Learning

An interaction is defined as a reciprocal action, effect or influence in which it is often occurred in the communication (Berge, 1999). Hence, it can be deduced that interactions are essential in the design process. In design learning environment, there is a few interactions occurred either to influence the artefact or the human being itself. The interactions can be categorised as human-artefact and human-human interactions. Both of these interactions are important to get the best artefact while doing it in the design process.

As the interactions occurred, one must know the current insight of design learning environment apart from the process cycle itself which is propose, critique and iterate. The current design learning environment follows a standard protocol. Firstly, it will go through a session where an understanding on the design brief and task takes place. After that, the design concepts are developed by drawing some free-hand sketches. Eventually, the design will be developed to the accurate scale. Lastly, some architectural tools are used to develop and visualised the idea (Rahimian et al, 2008).

Currently, there is still no existing tools which can beat the human mind. The complexity of human mind is the central for logic and creativity. Therefore, in the earliest stage of design process, it is essential to come out with an idea or a concept before proceeding to the next phase. Most of the time, the designers express their ideas by using free-hand sketching. Based on experience and knowledge that most probably will have a great influence in creating a design artefact, it is very rare to see exactly the same building designs happened concurrently.

Based on the knowledge and experience that possessed by the instructor, the concept of the design depends heavily on the used ideas (Lawson, 2001; Goldschmidt, 1998). Interactions also exist when the student is creating the design all alone (Schön, 1983). During the interaction between the student (human) and design artefact, he or she needs to argue and rely on themselves to create it. Usually, an individual student must put him/herself in a lot of shoes and act as a whole team that might consist of architect, engineer, quantity surveyor, and more. As there is still neither technology nor tools existed in creative thinking, the human mind is still the best tool to express the design idea and concepts.

A study shows that, contributions and interactions of ideas from different perspective can produce more creative artefacts, as compared to doing it all alone (Lugt, 2002; Paulus & Yang, 2000; Taggar, 2001). Thus, it depicts that interactions between human-human is crucial to improve the current design artefact. At the same time, this will be an added value and skills towards the students. During the conceptual and ideation proposal of the design artefact that has been created by the students, a criticism must be made towards the proposed idea and eventually will become a successful design interaction (Goldschmidt, 1995; Lawson, 2004).

The interaction between the instructor and students shows that collaboration of idea occurs during critique phase (Lawson, 2004). In order to get the most successful architectural design creation, Goldschmidt (1995) claimed that, most of the design idea creativities rely and adopt from the evaluations during the interactive or interdependent process. Most of the time, the criticism made between human-human interaction is needed for the students to view their design artefact from another angle or perspective. Thus, the interactions between the instructor and students are crucial as the conceptual idea of the artefact is analysed for further improvement (Lawson, 2005).

B. Studies on Human-human Interaction in Design Learning

To get the best design artefact, the students need to undergo a design process where interactions occur throughout the environment. A lot of studies has been conducted to show that interactions between humans are important to improve the design. Table 1 shows the existing studies on human-human interaction which is focusing in design domain.

Table 1. Existing studies on human-human interaction in design practice.

Authors	Details on how human-human interactions occurred
Nam & Sakong (2009)	Developed a prototype where the users could interact and collaborate in real-time.
Stolterman (2008)	Used a prepare-for-action which acted on the situation while improving the interaction in design practice.
Rahimian et al (2008)	A dialogue session took place in regard to the design problem and provided alternatives towards the arouse issues.
Hailpern et al (2007)	The designers could collaborate and create their design artefact in a synchronous collocated environment.

Table 1 shows the existing studies on human-human interaction in design practice. The design domain from the studies in Table 1 may not concentrate on architectural domain. As stated before, design consists of multi disciplines that can be implemented in real life. Studies show that the interaction between humans are important in improving their current idea on their design artefact. The authors stated that, even though collaboration of ideas and critical criticism has been made during the design process, a medium is needed to interact among each other.

The medium for interaction is also important in design learning. Most of the time, the medium is created to convey the knowledge sharing between two designers. In addition, a medium is also used to improve the design artefact as the interactions most of the times occur in synchronous and simultaneous manner. Hence, as the interactions occur, it increases the efficiency in collaboration (Nam & Sakong, 2009).

III DESIGN AS TACIT KNOWLEDGE AND ITS TRANSFORMATION

Design is used in various disciplines and occasions. It becomes one of the fundamental concepts when it comes to creating an innovation. To design, one must have the creativity to create it. Most of the time, the designers are born with creativity. However, to enhance the skills and creativity, the designers can learn it from the experts in most Architecture schools.

The design process shows its complexity during the critique phase. The idea of creating an artefact can be designed through one's experience, themes or interests. The evolution of idea by facing each critique

session has transformed the design artefact from time to time. Meanwhile, the students need to shape their developed artefact based on their primary idea. At the end of the day, the students will come out with different architectural design from each other. Thus, the complex of the design learning environment contains the tacit knowledge only can be showed or gained by both of the instructor and students.

Design learning, like most pedagogies, contains tacit knowledge. Sanchez (2004) defined tacit knowledge as a personal nature and hard to extract from one's brain. Meanwhile, he also explained that explicit is a knowledge where it can be easily explained by someone with any type of assistance. Tacit knowledge does not stop at the individual skill, experience and own knowledge, it can also be observed in the form of interactions and collaborations between them (Puusa & Eerikäinen, 2010). Therefore, through the intervention from the instructor while the students prepare their artefact, it is essential to process the tacit knowledge into explicit.

There are a few tools that can transfer and transform the knowledge. Although there is a few methods to get the knowledge, it must undergo a process of transformation from tacit to explicit. Hence, the explicitly readable design process can be used or revised for future references by undergoing a particular process. Most of the previous studies found that it is difficult to capture and transform the tacit knowledge into explicit. However, Nonaka & Takeuchi (1996) proposed a method in SECI model which can be seen in Figure 1 below.



Figure 5. SECI model proposed by Nonaka & Takeuchi (1996)

Figure 1 depicts the SECI model proposed by Nonaka & Takeuchi (1996). They stated that, each knowledge can be converted or transformed and seen as continuous learning. There are four processes in this model which are socialization, externalization, combination and internalization. Based on SECI model in Figure 1, to transform from tacit to explicit knowledge, a process called externalization will be focused on. There is a few cases that has been involved in externalization process which are articulating an individual tacit knowledge that

involves idea or visualization in words, metaphor and analogy.

From the externalization process in the SECI model, a protocol has existed while the knowledge exchange occurs. It structures the information exchange in such a way that the provider of information or a recipient of information can capture the information in a mannerly method. It clarifies and interprets an individual's knowledge into an understandable format for the others. In addition, a storyline in a narrative is also one of the best methods to share the knowledge and mostly occurs during interactions (Khalid & Mahmud, 2008). Hence, this can be shown during the design learning process where the knowledge sharing often occurs. Eventually, a transformation from tacit to explicit can be done.

In design learning, the instructor will share their knowledge and experiences to the students while practicing design in the learning environment itself. Then, the students will exchange the knowledge that they gain from their instructor explicitly during the critique session. The notes that they have taken will be in a readable format for them and it will be used for future improvements of their design artefacts.

IV DISCUSSION

A. Design Interactions in Knowledge Transformation Process

Interactions are essential in a design learning process. To get the best design artefact, a collaboration of ideas between human beings are needed in order to get the feedbacks. In the critique phase, this is where the interaction between instructor and students occurs. Through design learning environment, it promotes the knowledge sharing as it passes the knowledge from the instructor to students which often occurs in the studio session. Based on the studies, we have learned that design learning is filled with knowledge. Most of the knowledge are gained from the theory, feel and

experience. Then, this knowledge will be passed to the students from the instructor in the critique phase. However, the criticisms that have been made by the instructor are solely based on the ideation proposal from the students. Furthermore, every word said by the instructor should be taken into consideration for further improvement on the design artefact. Thus, it shows that tacit knowledge plays an important role in a design learning environment.

In the current environment, the students will propose their ideas and concepts through one-to-one communication. As they propose, they should get a feedback on the artefact in order for them to improve and make some changes on it accordingly. So, this is where the instructor will intervene by giving some constructive criticisms towards the ideation proposed by the students. Most of the time, the students will jot down what they can capture or gain from their instructor during the critique session. Based on the current method, the students will forget on how to implement some of the main points regarding on the criticisms made in the iterative phase.

Through SECI model, it is found that the tacit knowledge in design learning can be transformed into explicit through a process called externalization which can be seen in Figure 1. The transformation process is essential so that it is easier to archive the readable knowledge. The stored knowledge can be used in different ways such as to refer to the comments made by the instructor, for future references in learning and to get some inspirations for the others. To be in line with the technology era, the usage of current tool is needed to transform the knowledge in an easier way compare to the current method.

To transform the knowledge in a design process, a tool from the current technology is needed to assist and eventually, act as a scaffolding tool in the learning environment. A framework on the knowledge transformation in design learning is depicted in Figure 2.

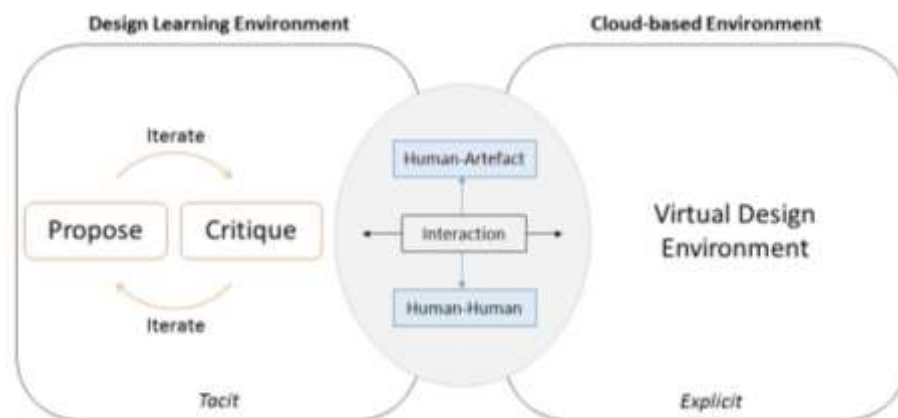

Figure 6. Virtual design environment for knowledge transformation (Lin et al, 2014; Brocato, 2009; Mohamad, Khaidzir & Ibrahim, 2015).

Figure 2 shows a framework to accommodate the knowledge transformation of design learning in a virtual environment. It involves a method to capture the tacit knowledge within the design learning processes. In addition, it should transform and represent these knowledges into explicit knowledge in order to facilitate human-computer interaction in a new scaffolding model of virtual studio class. To transform the knowledge, the usage of current technology as a scaffolding tool is needed to visualise the explicit knowledge that has been transferred through interactions between the instructor and students during the design process.

Nowadays, the technology is evolving from time to time. With the latest technology offered in the market, many can be used in facilitating the interactions between human beings. Through the technology tool, the instructor can intervene with the students' design artefact and at the same time, act as a scaffolding tool to facilitate the interactions. Therefore, the technology can be easily used as a transformation tool to support the design learning process.

B. Cloud Technology as a Virtual Scaffolding Tool

Nowadays, the technology has evolved from time to time and has been implemented into the learning system. Most of the technologies created in today's world are engineered to cater and connect the people even in a non-located venue. When people are connected with each other, this is where the interactions take place. Thus, the most suitable tool to interact among each other is none other than the cloud technology.

Cloud technology has its own specialty where people can interact and collaborate with each other. The users store their data in a remote cloud server and eventually, they can access their files anywhere they go as long as there is an Internet connection provided. Besides having it ease on accessing the documents, the cloud technology also provides a dynamic front-end environment, which is often described as Software as a Service (SaaS), to cater the learning process.

Based on previous studies, it is found that cloud technology is most of the time being used in the learning activities (Mohamad, Khaidzir & Ibrahim, 2015). With the implementation of cloud technology in design learning process, it can act as a scaffolding tool where it exists in a virtual environment. From Figure 2, it shows that the usage of cloud technology is supporting the design learning knowledge transformation process. This occurs when the students use the virtual environment to visualise their

architecture artefact and its evolution towards the instructor.

The visualization on the improvement and evolution of design artefact via the usage of the cloud technology will depict that it is the explicit version of the complexity and tacit that took place during the critique session. Therefore, a cloud technology is proposed to become a virtual scaffolding tool in viewing its efficiency to assist the transformation of tacit knowledge into explicit in design learning environment.

V CONCLUSION

Design learning is known for its design process where most of the interactions occurred during the critique session. As it promotes the interactions between the instructor and students, thus the transfer of knowledge also happened in the process. As the learning environment itself contains a lot of tacit knowledge, hence this study investigates a method to transform the tacit knowledge in design learning to explicit.

The interaction is among the many things that are important in design learning process. Via interaction, it can transfer the knowledge or information from an instructor to a student in a short duration of time. The teaching and learning session in an architectural design environment often envision the interactions as a scaffolding tool to improve one's artefact design. The knowledge that has been learnt and gained in the critique phase will not be the same for each student because it depends on their ideas and creativity while producing the artefact.

A framework model on knowledge transformation in a virtual design environment has been developed to cater the interactions in design process. It should be capable of capturing the interactions in learning while participating the design process. This paper focuses on the importance of interactions between instructor and students which often contains the tacit knowledge. A process is needed to be used to transform the knowledge from tacit to explicit. In order to do that, the usage of existing technology is essential in acting as a scaffolding model of a virtual environment.

To conclude this paper, current technology is needed to transform the tacit knowledge of design learning into explicit easily. In addition, the technology used should also act as a scaffolding tool for the learning process to take place. For further investigation, the cloud technology will be as a proposed tool to transform the tacit knowledge gained through the learning and archive it into something readable for future references.

ACKNOWLEDGMENT

This study is funded by Universiti Teknologi Malaysia, Skudai through the Teaching Development Grant (Dana Pembangunan Pengajaran DPP 2015) entitled 'Peer Instruction in Virtual Collaboration Environment of Studio Based Learning' (R.J130000.7721.4J165).

REFERENCES

- Berge, Z. L. (1999). Interaction in Post-Secondary Web-based Learning. *Educational technology*. 39(1), 5-11.
- Bouton, M. E. (2007). *Learning and Behaviour: A Contemporary Synthesis*. Sunderland, MA: Sinauer Associates.
- Borchers, J. O. (2001). A Pattern Approach to Interaction Design. *AI & Society*. 15, 359-376.
- Brocato, K. (2009). Studio Based Learning: Proposeing, Critiquing, Iterating Our Way to Person-Centeredness for Better Classroom Management. *Theory into Practice*. 42(2), 138-146.
- Goldschmidt, G. (1995). The Designer as a Team of One. *Design Studies*. 16(2), 189-209.
- Hailpern, J., Hinterbichler, E., Leppert, C., Cook, D., & Bailey, B. P. (2007). TEAM STORM: Demonstrating an Interaction Model for Working with Multiple Ideas During Creative Group Work. *C&C '07 Proceedings of the 6th ACM SIGCHI Conference on Creativity & Cognition*. 13th-15th June. Washington, DC: ACM, 193-202.
- Khalid, K. S. B. & Mahmud, A, K, B. (2008). A Proposed Organization Storytelling Conceptual Framework for the Purpose of Transferring Tacit Knowledge. In: Information Technology, 2008. ITSIm 2008. International Symposium on, 26-28 August 2008. 1-8.
- Lawson, B. (2004). *What designers know*. Oxford: Elsevier.
- Lawson, B. (2005). *How designers think*. Oxford: Elsevier.
- Lim, Y., Lee, S., & Kim, D. (2011). Interactive Attributes for Expression-oriented Interaction Design. *International Journal of Design*. 5(3), 113-128.
- Lugt, R. (2002). Brainsketching and How It Differs from Brainstorming. *Creativity and Innovation Management*. 11(1), 43-54.
- Mohamad, N. A, Khaidzir, K. A. M., & ., Ibrahim, R. (2015). A Framework on Cloud Technology in Facilitating Design Learning. *ARPJ Journal of Engineering and Applied Sciences*. 10(23), 18130-18137.
- Nam, T., & Sakong, K. (2009). Collaborative 3D Workspace and Interaction Techniques for Synchronous Distributed Product Design Reviews. *International Journal of Design*. 3(1), 43-55.
- Nonaka, I. & Takeuchi, H. (1995). *The Knowledge-creating Company: How Japanese Companies Create the Dynamics of Innovation*. Oxford University Press.
- Paulus, P. & Yang, H.-C. (2000). Idea Generation in Groups: A Basic for Creativity in Organizations. *Organizational Behaviour and Human Decision Processes*. 82(1), 76-87.
- Puusa, A., & Eerikäinen, M. (2010). Is Tacit Knowledge Really Tacit? *Electronic Journal of Knowledge Management*. 8(3), 307-318.
- Rahimian, F. P., Ibrahim, R., & Baharudin, M. N. (2008). Using IT/ICT as a New Medium toward Implementation of Interactive Architectural Communication Cultures. *2008 International Symposium on Information Technology*. 3, 1-11.
- Sanchez, R. (2004). "Tacit Knowledge" versus "Explicit Knowledge" Approaches to Knowledge Management Practice (No. 2004-01). Department of Industrial Economics and Strategy, Copenhagen Business School.
- Stolterman, E. (2008). The Nature of Design Practice and Implications for Interaction Design Research. *International Journal of Design*. 2(1), 55-65.
- Taggar, S. (2001). Group Composition, Creative Synergy, and Group Performance. *Journal of Creative Behavior*. 35(4), 261-286.
- Wertheimer, M. (1945). *Productive Thinking*. New York: Harper Torchbooks.

The Impact of Collection and Dissemination of Information towards Public Complaint on Municipal Services

Zaherawati Zakaria¹, Kamarudin Ngah², Nazni Noordin¹, and Mohd Zool Hilmie Mohamed Sawal¹

¹Universiti Teknologi MARA (Kedah), Malaysia, {zaherawati; nazni ; zoolhilmie }@kedah.uitm.edu.my

²Universiti Utara Malaysia, Malaysia, kamarudinngah@uum.edu.my

ABSTRACT

The Ministry of Housing and Local Government (MHLG) has introduced the Key Performance Indicators (KPIs) to enhance the delivery of public services to customers due to 50 per cent of complaints received were on the failure or delays in attending or responding to the needs of customers. By using quantitative method, this study attempts to examine the extent of collection and dissemination of information towards public complaints on municipal services. The finding shows the strong association between customer satisfaction and social characteristics of feedback towards complaint and information channel in Majlis Perbandaran Sungai Petani, Kedah (MPSPK). Based on the findings, in order to make customer satisfaction increase on municipal services, future strategies need to be done by focussing on the way of collection and dissemination of information among households.

Keywords: Information, Complaint, Knowledge, Customer Satisfaction, Municipal Services.

I INTRODUCTION

In Malaysia, there has been growing media attention on cases of public sector customer grievances, especially at the local government level. The response has been pushed to improve the quality of public service delivery. The Public Complaints Bureau under the Prime Minister's Department revealed that around about 17% of total complaints on civil service are on local governments. Much has been written about how IT could be and has been used to enhance service quality (Ali & Green, 2007; Zhu et al., 2002). Jabatan Kerajaan Tempatan (JKT) is department under the Ministry of Housing and Local Government (MHLG) and the main function is to guide and facilitate the Local Authorities (Pihak Berkuasa Tempatan-PBT) with planning and implementation of socio-economic development programmes and municipal services. The drivers for this research have arisen in response to a numbers of perceived weaknesses in service delivery identified in various sources. Many municipalities including Majlis Perbandaran Sungai Petani kedah (MPSPK), however, are unable to deliver services to residents especially in sanitation, cleanliness, drainage and culverts matters (MPSPK, 2010).

The Complaint statistic produced by Public Relation Officer (PRO) in 2010 shows the total of public

complaints of e-aduan, Unit Gerak Cepat and Biro Pengaduan Awam in 2007 until 2011. The data shows until August 2011, e-aduan is the highest channel used by the customers in lodging their complaints. This time series from 2007 until August 2011 concluded that the most favourable channel in giving information and complaints is e-aduan.

II LITERATURE REVIEW

The customer of local government services maybe an individual, local community interest group, one or more elected members of government department or ministry, internal staff, but enlarge the customer in any member of the public (Brysland & Curry, 2001). There are many sources of literature that identify how to achieve the customer satisfaction. This concept intends to summarize the key relevant literature in order to conceptualize the research into how MPSPK can improve its customer satisfaction through appropriate performance measurement tool (Crew, 1992).

The power of customer satisfaction in organizations has been proven by its nature as service needs to be listened. Someone who uses local services refuse to pay them directly, so they have less chance to signal their preferences. In particular, citizens can end up with the services that someone else thinks they ought to have rather than those they really want themselves. The concept of the internal customers in services has evolved, originally through the idea of selling jobs in the service sector and making the job attractive for the employees (Reynoso and Moores, 1990). This idea is followed in wider terms as internal marketing by authors such as Berry (1981), Gronroos (1990) and Gummesson (1990). They have suggested that if the management staff wants the employees to deliver an outstanding level of service to customers, then they must be prepared to do a great job with their employees. According to Schneider & Bowen (1985) consultation and community development are seemed to be the essential part of service delivery and performance measurement in local authorities. According to Unwin (1975), there is a bewildering range of indicators that had been proposed in past studies to measure satisfaction in municipal services; however this study specifically interested in the following aspects of feedback toward complaints and

information channels. A research shows that 35% of complaints (across all sectors) are met with a response of 'seemed uninterested' (Kamarudin et al., 2012). However, where complaints are met with a positive and helpful attitude, customer satisfaction with the handling of the complaint is significantly higher. This suggests that an employee's response when a complaint is first raised is crucial in setting the tone for the way the customer views the whole experience. For example, where customers felt an employee 'listened carefully and wanted to fully understand the problem' they gave a satisfaction score of 4.4 points (on a scale of 1 – 10) – higher than customers who felt the employee 'seemed uninterested'.

There are a number of key steps organisations can take to improve customers' experience of reporting complaints or problems. These include providing a choice of methods to make a complaint; undertaking root cause analysis of what's causing common complaints, agreeing a timescale for resolution, and following up with customers after the issue has been resolved. Some 20% of the Institute's membership is made up of public sector organisations. All are members because they believe in the importance of having a customer service strategy and are committed to developing and improving the experience they give to customers (Kamarudin et al., 2012).

III RESEARCH METHODOLOGY

The method used in this study is quantitative though distributed of questionnaires to selected Zone (C, G and H) in Sungai Petani, Kedah. The instruments used in this study are households and employed stratified random sampling. Sample sizes of approximately 319 respondents of households are taken 0.4 % of population from each zone (Sekaran, 2003). The survey is done in Four months from April to July 2012 with the help of 4 enumerators and this study included 3 administrative zones of the MPSPK under Ten Zones for Area Officers' (AO) supervision such are Zone C, Zone G and Zone H. The selection of these zones is based on the variations of the housing and neighbourhood characteristics of their area. Zone C consists of 25 neighbourhoods and 6 villages. This zone was developed due to rapid development of industrial and business community lead to tremendous growth of neighbourhoods since 1990's (MPSPK, 2011). Many projects are developing at this zone which causes some problems. Some complaints are lodged among the residents due to unsatisfied of waste management, cleanliness, drainage and culverts affairs in some neighbourhoods such as Bandar Puteri Jaya and Kampung Pengkalan Lebai Man. The next zone is Zone G which is comprised of 15 neighbourhoods and 5 villages to be supervised by an AO consisting of the Head of Departments and councillors in respective area. This zone is divided into 2 main areas which are

Sungai Lalang in urban area while Bukit Selambau in rural area due to rubber estates and traditional villages. As suburban area, there are many commercial spots in Sungai Lalang. Most of the houses that can be spotted in Sg Lalang are the row of terrace houses and some medium to high-cost bungalows as well. The last zone chosen for this study is Zone H, comprises of 19 neighbourhoods and 8 villages to be in charged by an AO. This zone chosen due to its area is formerly known as tourism area such as Lembah Bujang, Semeling, Merbok and Tanjung Dawai and the result can be traced on what the community in this area perceived satisfaction on municipal services in different level or otherwise.

IV FINDINGS

A. Households Information profile

The sample of the study comprises of 310 respondents of households which male were the highest respondents with 156 (50.3%) followed by female with 154 (49.7%) and Malay ethnicity comprises the majority of respondents with 99 or 32 percent followed by Chinese 94 (30.3%), Indian 75(24.2%) and Siamese 42(13.5%). Respondents' ages are ranged from 40 to 49 years, with a mean of 2.965 (S.D =1.08). Majority of the respondents were never had any formal education (38.1%) followed by primary education (26.1%), post graduate (14.2%) and only 0.3 percent of the respondents are the STPM holders. 44.5% respondents in the sample are reported to work as general office administrator (44.5%), followed by professional, top management & administration (43.9%) and only 11.3 percent working as semi-skilled or unskilled manual worker.

In terms of category of house, majority of the respondents are from the "moderate" category (59.7%), followed by "Elite" category (29.7%) and only 1.6 percent respondents from "Low cost" category. Most of respondents came from Zone C (40%), followed by Zone G (35.8%) and 24.2 percent from Zone H. The respondents are reported to be in the private limited firm sector (44.5%), followed by governments sector (43.9%) and only 0.3 percent respondents working in multinational company. Most of respondents are married and followed by single (49.4%) and most of them are stayed 2 – 5 years (44.2%), followed less than a year (43.9%) and only 0.6 percent respondents in this study are stayed 6-15 years. 67.4 % respondents in the sample are reported having owned house and only 32.3 percent rented the house. The respondents are living in double terrace type which represents 33.5%, followed by single terrace (30.3) and only 21.6 percent living in bungalow type. This indicates that most of respondents are the middle income society.

B. Major complaints towards households

The study indicates that majority of household and business communities lodged complaints on cleanliness (mean=2) and drainage and culverts (mean=3). This finding shows that the cleanliness, drainage and culvert are the major problems facing by MPSPK. However, data does not reflect the earlier given which waste management is the major problems as described in e-complaint on the municipal website. As discussed in problems, the waste issues are the major complaints lodged by residents and have proven to be the core problem in daily operations of MPSPK. The different of result refers to different zones selected in Sungai Petani while the data from MPSPK was derived from 10 zones in Sungai Petani and this study only selected three zones. On the other hand, the weak management in handling cleanliness, drainage and culverts which lead to flash flood in selected zones derives to the highest complaint compared to waste management problems.

C. Complaint Response

Local government is frequently the first point of contact for the public in accessing public services. It is critical that local authorities deal with customers in accordance with the principles of courtesy, fairness, openness and transparency. In such an environment as found by Kloot and Martin (2000), customers should have the opportunity to say when service standards are not being met or when they have not been treated with courtesy and fairness. A responsive culture, which quickly resolves difficulties, can lead to a better way of conducting business with the public and also assist local authorities in improving the services they offer. Most local authorities have already taken the initiative to establish internal procedures for responding to concerns expressed by local citizens about service delivery, including in many cases of appropriate appeals mechanisms (Kamarudin et al., 2012).

From this study, it seems that the responses received after lodged complaints have a strong relation with customer satisfaction. Households felt satisfied with the statement of "Time taken to response is less than 30 minutes" while business respondents took "30 minutes to 1 hour" in dealing with the local authority as their major. The households also satisfied with the statement of "Feedback" with mean=2.155 and business communities with mean=2 shows the complaint received and in progress. In addition, the households felt having less communication in "Two ways communication" and they felt not sure on the "Satisfaction on public complaint". The result shows that households were not satisfied with the two way communications with the council due to unsettled complaints of the residents and the ineffective approach in disseminating and collecting information.

On the other hand, the majority of business respondents stood with very satisfied on the statement

of "Satisfaction on public complaint" and strongly communicate in "Two ways communication" with the MPSPK with the mean=5, while "Time taken" is more than 30 minutes to 1 hour and "Feedback" also received-in progress. From the business respondents, the findings found that they were very satisfied with the two ways communication due to the complaints of the respondent were noted accordingly and quickly settled within the schedule given. The findings also correlate with many previous studies on the positive association between the communications and timeliness in complaints system (Jonsen, 2001, Parasuraman et al., 1996, Norton and Kaplan, 1996). In addition, Jonsen (2001) feels that an individual may not be satisfied with the quality of a service provided by the local authority. A complaint may arise where an individual is dissatisfied with the manner in which a staff member interacts with him or her, the issue here may be on courtesy, fairness or openness. Such issues about the standard of service and appropriate to the complaints system, as in the view of the complainant the service, was not provided in accordance with good administrative practice.

According to Bowen & Hedges (1993), one possible method of determining which service quality dimensions is more important to different groups of customers is by utilizing customer demographics. An analysis is also undertaken to investigate which extent of demographic profile of respondents associate with the level of satisfaction in municipal services. From the study, it seems that the mean score of age and gender have significance differences towards awareness and satisfaction as resident or customer in Sungai Petani.

D. Information of Service Provider in Sungai Petani

Household respondents were disagreed with the statement of "List of contractors are provided", followed with "Address are given to the clients" with the lowest of mean=2.29. "Telephone number are provided" with mean=2.322 and "Schedule of operation are provided" at mean=2.456. At the same time, business respondents were also disagreed with the statement of "List of contractors are provided" and "Address are given to the clients" with the lowest of mean=2.4 while, they were agreed with "Telephone number are provided" and "Schedule of operation are provided" with mean=4.133. The mean rank indicates that respondents with low relative with the service and accessibility offer by E-Idaman especially the list of contractors/companies are not provided as they expected as well as no address given to customers accordingly. On the other hand, the residents also disagreed with accessibility of bags, baskets and bins as well as they felt that the municipal did not provide enough staff to run the services. It is due to the new operation of E-Idaman which is taking over the environmental functions of the local authority. At the

beginning of the services, many complaints were made to local associations, community leaders and councillors.

E. Collection and Dissemination of Information

The research question on whether the customers have enough aware of the opportunities for them to participate whether in formal or informal channels is revealed in this study. There are several channels used by MPSPK to collect and disseminate information to the residents. The finding identified that local associations are the preferred choice of channel used for the respondents to voice out their grouses and complaints on the municipal services. The local associations act as the representatives of the local government and work as the appropriate and effective channels to disseminate and collect information.

The acts of communicating with the politicians and councillors appear to be stronger and the finding shows that the strong relationship between respondents and local representatives which they most prefer to communicate with community leaders. Newspaper, e-complaint, mailing, online forum are among the additional communication tools identified as being effective in disseminating and collecting information from MPSPK's residents. The possible explanation on why the most appropriate and effective channels are contacted by local associations and community leaders is due to easy way of face to face in dealing. Other reason is due to the residents was not friendly enough with the technologies in advanced and most of them were in range of 40-49 years old. The study also found that the usage of the internet and electronic displays are not considered appropriate by the respondents. However, the data does not reflect the actual fact on how complaints are made through e-complaint as compared to other channels as proven by MPSPK itself. This is not a surprise finding as it has been proven in previous study that low usage of ICT application among the population of Seberang Perai (Kamarudin et al., 2002).

V DISCUSSION AND RECOMMENDATIONS

From the study, it is concluded that the community of Sungai Petani is largely satisfied with the municipal services provided in Sungai Petani. The majority of the respondents preferred to use the former channels of local associations and community leaders in disseminating and collecting information. In addition, further analysis on the level of dissemination and collective information by using other qualitative methods such as online archival records from the e-complaint and councillors' blogs also are found the best to be the platform of this study. It is proven that there are a small number of active residents who depend on information technology as the main tool in garnering collective actions in order to influence

public complaint systems. These active residents are described by Putnam (1993) as cyber activists who utilize the information technology to gain widespread support from the wider population and capture the attention of the higher authority to review their decisions.

This study finds that respondents from households basically agreed with cleanliness, drainage and culverts as their main problem in local affairs. However, this finding does not reflect with the data given by MPSPK earlier that waste management was the highest public complaint in their area. This study also indicates that service provider and accessibility offered by E-Idaman were disagreed. Many of households have the same feeling that the service provider did not provide the complete the list of address and the telephone of contractors and companies. The accessibility is not enough in terms of facility, equipment and publicity to the people. One conclusion that derived from these findings is that the service provider has lack of publicity and not enough facility to run the services. Even the equipment's like bins and other tools are supported by the municipal; they still seem incompetent to perform well.

Other variables of feeling when dealing in MPSPK is found related to satisfaction level on municipal services while frequent of dealing, time waiting in dealing, feedback and response, satisfaction given and service received have a positive association with municipal services. On the other hand, the other variables in response received after lodged complaints seem to have the strong relationships with the customer satisfaction while the household and business community do satisfy with the time taken, feedback, two way communications and process in public complaint.

As recommendations, knowledge and understanding about the daily operations of municipal services are needed in order to encourage the local people to be more satisfied. The awareness among public is important as to voice out the dissatisfaction and to complain on the right channel. It is important for a municipal council to have a comprehensive understanding on the focus groups that exist in a community. Public should not be treated as one single entity as there are different kinds of people who take on municipal services differently. The municipal should also take into consideration the existence of organized and unorganized public and whose interest do they represent. There are instances where a municipality might feel that instead of providing the service directly, they would rather hire someone else (service provider) to do it. It is important to provide services that are affordable but municipalities must do so without compromising on its ability to operate and maintain existing services by having municipal service

partnership (MSP) is an agreement between a municipality and a service provider (Gronroos, 2007 and Parasuraman et al., 1996).

VI CONCLUSION

There are a lot of things and practices need to be done as to improve the quality of customer satisfaction, and lift it to be a higher level. But, in the nutshell, the strategies must target on strengthening the focus groups: households, business communities, local associations, councillors, community leaders and officer, as suggested in the previous sections in this chapter. While, it is important for the public to have awareness and sense of citizenship as to make them concerns on the municipal services in accordance. On the other hand, the government needs to be creative in engaging public, and emphasizing what is equally important factor for the public to be more connected to their neighbours. The councillors and officers need to foster community solidarity when they are holding position in helping and making the neighbourhoods as much more desirable to have a quality of life, and as good citizen in their localities. Therefore, apart from focusing on improving customer satisfaction process and the system of public complaints, future policies and rules should also be directed on the relationship with local associations and representatives as well as concern on the political ideologies accordingly.

ACKNOWLEDGMENT

Our sincere thanks goes to our colleagues in UiTM Kedah and UUM, Malaysia for whom we have great regard, and we wish to extend our warmest thanks to all those who have helped us with the creation of this paper.

REFERENCES

Ali, S. and Green, P. (2007). IT governance mechanism in public sector organizations: An Australian context. *Journal of Global Information Management*, 15(4), 41-63.
 Berry, L. L. (1981). The Employee as a customer, *Journal of Retail Banking*, 3(1), 33-40.

Brylsand, A. & Curry, A. (2001). Service improvement in public service using SERVQUAL, *Journal of Managing Service Quality and Performance*, 11(6), MCB University Press.
 Bowen, J.W. and Hedges, R.B. (1993). Increasing service quality in retail banking, *Journal of Retail Banking*, 15, 21-8.
 Crew, R.E. (1992). *Politics and Public Management: An Introduction*. New York: Saint Paul.
 Gronroos, C. (2007). *Service Management and Marketing. Customer Management in Service Competition*, Chichester: John Wiley & Sons.
 Gronroos, C. (1990). *Service Management and Marketing: Managing the Moments of Truth in Service*, Lexington: M.A.
 Gummesson, E. (1990). *The part-time marketer*, Service Research Centre-CTF, University of Karstark.
 Johnsen, Å. (2001). Performance auditing in local government: an exploratory study of perceived efficiency of municipal value for money auditing in Finland and Norway, *The European Accounting Review*, 10(3), 583-599.
 Kamarudin, N., Zaherawati, Z., Nazni, N., Jamaludin, M. and Mohamad Zoolhilmie. M.S. (2012). The Process of Decision- Making Among Councillors At Local Government Level: A Case Study At Kuantan Municipal Council, *ISBEIA 2012 (2012 IEEE Symposium on Business, Engineering & Industrial Applications)*, 23-26 September 2012, Bandung Indonesia.
 Kaplan, R.S. and Norton, D.P. (1996). Using the balanced scorecard as a strategic management system, *Harvard Business Review*, January-February, 75-85.
 Kloot, L. and Martin, J. (2001). Accountability in Local Government: Explaining Differences Accounting, *Accountability and Performance*, 7(1), 51-72.
 Majlis Perbandaran Sungai Petani (2010). Jabatan-jabatan di dalam Majlis Perbandaran Sungai Petani, *Laman Web rasmi MPSPK*. [Online] Available at: http://www.mpspk.gov.my/web/guest/mpspk_department [Accessed: 10 July 2010].
 Majlis Perbandaran Sungai Petani. (2011). Administration Area *Official website of MPSPK* [Online] Available at: http://www.mpspk.gov.my/web/guest/mpspk_background [Accessed: 5 February 2011].
 Parasuraman, A., Zeithaml, V. & Berry, L. (1996) The Behavioural Consequences of service Quality. *Journal of Marketing*, 60, 31-46.
 Putnam, R. D. (1993). *The prosperous community: social capital and public life*, *American Prospect*, 4, 13.
 Reynoso, J. and Moores, B. (1990). Towards the measurement of internal service quality, *International Journal o Management*, 6 (3), 64-83.
 Schneider, B. and Bowen, D. (1985). Employee and customer perceptions of service in banks, *Journal o Applied Sociology*, 7 (3), 423-433.
 Sekaran, U. (2003). *Research Methods for Business: A Skill Building Approach*, Singapore: John Wiley & Sons, Inc.
 Unwin, S. (1975). *Customised communication, a concept of service*, London: Prentice Hall.
 Zhu, F. X., Walter, W., & Chen, I. (2002). IT-based services and service quality in consumer banking. *International Journal of Service Industry Management*, 13(1), 69.

The Formulation of New Model of Decision-Making Process in Malaysian Local Government

Kamarudin Ngah¹, Ravindra Nath Vyas¹, Mohd Fitri Abdul Rahman¹, and Zaherawati Zakaria²

¹Universiti Utara Malaysia, Malaysia, {kamarudinngah; ravendra ; mohamadfitri} @uum.edu.my

²Universiti Teknologi MARA (Kedah), Malaysia, zaherawati@kedah.uitm.edu.my

ABSTRACT

Currently we are witnessing significant changes in the nature of policy making and management at local government level. These changes represent a move away from the relatively passive approach to a more purposeful approach in which local authorities attempt to learn about the nature of local problems and to respond accordingly. Thus, this paper tries to propose a model of decision-making process for greater performance in local government by taking Malaysian local government as a case. In the findings, there are a few factors influencing councilors in running their functions. It shows that councilors as representatives at local government level will be a good policy maker in handling local issues by adopting this proposed model. In future research, in order to have a greater practice of rational decision-making, perhaps the stakeholders such as households, business communities, community leaders and non-government organizations will be collaborated effectively with councilors in decision-making process relates to local affairs.

Keywords: Model, decision-making, local government, knowledge, management, policy.

I INTRODUCTION

The study of power relationships in urban planning has tended to focus on a narrow definition of power rather than using power as the central concept in explanation of decision-making process and formulation of planning policies. Even though few studies of local government councilors are available, there is little doubt that more is known about the roles, values and attitudes of elected members than about any other component of local government. The traditional studies of councilors examined the relationship between councilors, parties, officials and interest groups (Lee, 1963; Rees & Smith, 1964; Newton, 1976, Collins, 1978) and have led to the evolution of interesting but ultimately disappointing models of political behavior in local government. The focus on councilor role orientation and formal political groups assumes that power or influence is concentrated in one, easily recognizable, arena-the council chamber and the political party. Such models assume that local representative is collectively and

continuously involved in the process of policy-making. Therefore, the objective of this research is to construct a theoretical framework or model, which leads to a better description, understanding and analysis of decision-making process at local government level, demonstrating a potential of this model among councilors in order to improve influences acting upon decision-making process and formulation of local planning policy. The application of this model will benefits the good governance practices at local government level, and will contribute to a better urban living environment and urban quality of life.

II LITERATURE REVIEW

A. Decision-Making in Local Government

Much attention has been focused in recent years on the basic challenge of planning in a democratic society. Decision-making in local government addresses itself in particular to those more strategic levels of choice which tend to be linked with the terms 'planning' and 'policy-making', and to impinge on the future physical and social development of local communities in a variety of ways which may be only imperfectly understood. The planning process in local government requires a technology of choice that explicitly recognizes the particular types of challenge posed at this level. These include the difficulty of isolating one decision from another. If such a technology is to be consistent with the principle of democratic control, new approaches will be necessary of internal organization and communication within local authorities (Friend & Jessop, 1971). In local government, the committee meeting is the only official occasion at which officers and elected members meet together, and at this stage the recommendations of the officers-if acceptable-become translated into formal decisions of the members. However, despite the formal significance of the occasion, it was evident to us that, particularly where the more strategic decisions were concerned, the committee meeting tended to play a strictly limited role in the actual processes of decision-'making', which extended well beyond the formal procedure of decision-'taking' enshrined in standing orders (Friend & Jessop, 1971).

B. The Role of Councilors

Amongst the most compelling and convincing arguments for any form of sub-national, territorially based structure of representative government is that it brings political decision-making closer to local communities. Decision-making by local elected representatives has a local democratic mandate, and by being more immediate to local communities, it can turn to be far more responsive to local wishes than national government. Thus, local citizens can be assured that the views they articulate will be heard by councilors, and that councilors in turn, will be concerned not only to respond to, but also to anticipate the reactions of the electorate to policies they develop and decisions they make (Gregory, 1969). Despite the general spread of party politics in local government, councilors are well entrenched in their communities and their role is primarily one of 'defending their local interest regardless of party considerations' (Copus, 2004). In the British local context, Jones (1973) noted that, as well as representing a geographical area, the councilor may also act as representative of a broad section of the community, a particular organized group, another local authority or individual citizens.

C. Crisis of Representation

A crisis of representation occurs when the councilor react to a council policy pronouncement, a specific local issue, or decision that stimulates the interest of the community, or section of it, and motivates them into action. The issues must be significant salience for the community, to mobilize and to begin to articulate. The crucial importance to the generation of a crisis of representation is that the councilor agrees with the views of the electorate on the matter, and expects the councilor to oppose the council decision and work in support of the position. The crisis is further intensified by two different sets of assumptions held by representatives and represented. Whilst the group meeting is the decision-making forum, the group itself will still expect the councilor to publicly adhere to the decision or policy that is cause of public concern (Copus, 2004). Councilors generally recognize that the responsibility of representing the interests of an electoral area will involve conflict with the group, particularly over very sensitive local issues. Another way in which the councilor may seek to resolve the crisis is to change the group's decision. However, this is a closed process, which involves private debate within a group meeting and private negotiations between councilors. It does not lead to public deliberation, which is still shunned as a way of resolving matters (Copus, 2004: 192). Eulau et al. (in Copus, 2004) explored the concept of representative 'focus' that is where the representative will concentrate his or her attention when it comes to the political processes. Jones (1973) noted that, as well as representing a 'geographical' area, the councilor may also act as a representative of a broad section of the

community, a particular organized group, another local authority or individual citizens.

III RESEARCH METHODOLOGY

This grounded theory/model focused on literature review, observation on previous theories or models and application of those theories or models in local government's decision-making process. The main objective through this application is to determine what factors influence councilors in their decision-making process. Qualitative method through interview was carried out with councilors of Kuantan Municipal as well as key informants with informal discussion with external discussion at different level of society.

IV FINDING AND DISCUSSIONS

A. The Process of Decision-Making

The study indicates that most councilors perceived the decision-making is a complex process, by referring to the second and third level of formal sequences of steps in the decision-making process.

In some conditions, the formal process of decision-making became more complex due to the involvement of various inter-departmental inputs. The agencies may unable to reach any decision or majority councilors may disagree with the decision that needs to be endorsed.

The study also sharing the similar finding as carried out by Fried and Jessop (1969) in the City Council of Coventry, United Kingdom, on the complexity of the decision-making process. There was a constant sense of the direct exposure of the elected or appointed member to many conflicting pressures of the electorate and, for this reason, the resolution of conflicts through discussion within the party group often appeared to embody a higher level of realism than did attempts to reach decisions involving similar conflicts of interest either in the committee or departmental meetings.

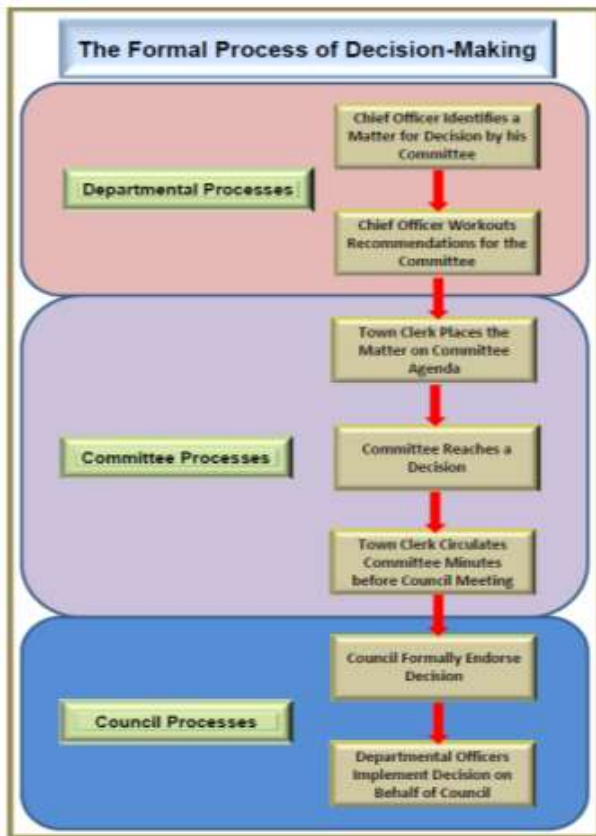

Figure 1. The Formal Process of Decision-Making

B. Factors Influencing Decision-Making

The results of what councilors thought the most important factors influence their decision-making throw some light on the issues central to understanding the dynamics of political preference in the process. Four factors indicate councilor's preference, namely; i) the interest of the public/tax payers, ii) the interest of state government, iii) the interest of the party, and iv) economic and infrastructure development. From the list, it can be summed up that most councilors realize that their actions should not be contradictory and against the policies decided upon by the state or interest of the party and the people. At the same time they carry the responsibilities to draw the policy to determine the direction of the local council and the direction has to augur well with the state policy and meet the people's expectations.

The similar approaches has been conducted by Young and Rao (in J. Curtis et al., 1995) for Widdicombe Committee, United Kingdom, in identified what was the councilor focus of representation, from the point of view of the public. Electors' expectations of their councilors are inescapably conditioned by the prominence in local government elections and local politics of national party politics. Equally important are electors' attitudes towards the balance needed between a councilor's own personal views, those of his or her party and those of the people he or she

represents (Copus, 2004). Young and Rao conclude that in a system dominated by the party group: 'there is an overwhelming expectation that councilors should place local interests-either at ward level or across the local area-first. And there is also a clear indication that the public thinks there are limits to the role of party politics (Young & Rao, 1995). As the link between the party and councilor is stronger than that between the councilor and the electorate, the councilor will act as a trustee when it comes to developing a representative relationship with citizens, but will act as a delegate when it comes to his or her relationship with the party or the party group.

V RECOMMENDATIONS AND CONCLUSION

A. Enhancing the Role of Councilors

It requires serious questioning of the nature of local representative democracy and the role played within it by political parties and party people. By playing the role as community advocate, councilors will ensure looking inwards to the needs of micro-managing the party group and its internal factional machinations, rather than outwards towards the needs of community leadership and governance (Copus, 2004). However, as perceived by Friend and Jessop (1971), the test of 'improvement' can only be an empirical and to some extent a political one; whatever change is proposed in existing mechanisms of choice, it must be such as to gain acceptance in practice, by convincing a sufficient number of people that it offers them a better instrument for achieving the things they want to achieve.

B. A New Proposed Model of Decision-Making Process

The new proposed model of decision-making process at local government level is based on 13 factors that influence any decisions made by councilors in regards to council's affairs. The rational of having this option is to assists councilors in making a right, efficient and effective decisions by considering all those factors, collectively and comprehensively. The six main factors; i) The expectation of tax payers; ii) the interest of political party; iii) in parallel to the state; iv) in parallel to the federal; v) the impact on environment and vi) the socio-economic will give a different weight on the importance of each factors. In conjunction to the recommendation of becoming advocate councilors, they need to be alert to the characteristics and needs of the people they serve, and, where inequalities exist, councilors need to help ensure that they are well addressed (Figure 2).

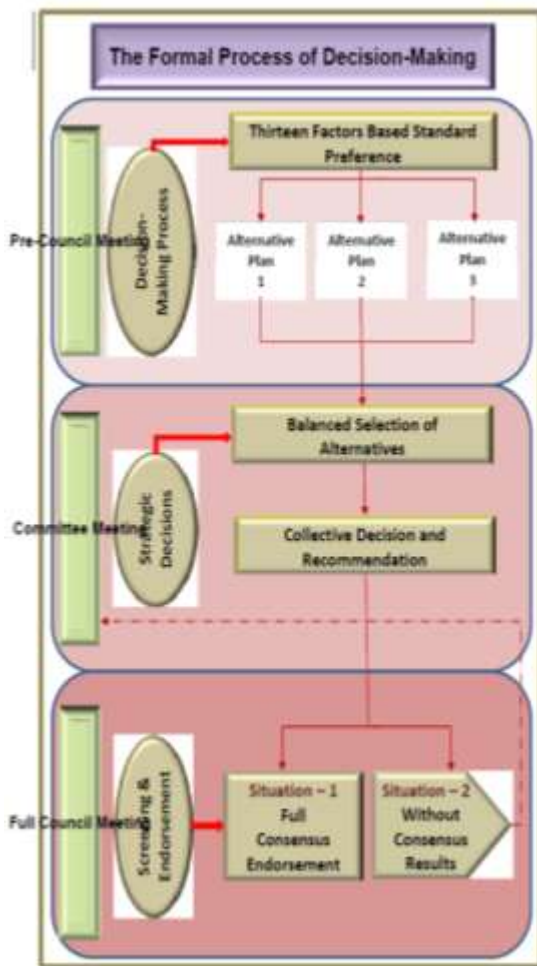

Figure 2. Proposed Model of Decision-Making

The application of the model begins at the pre-council meeting. The pre-council meeting should providing a forum for the debate of particular controversial issues at the stage before a formal committee decision was reached, either at the Committee Meeting or Full-Council Meeting. A consensus result or a firmly stand could be finalized, after considering the few alternatives or possibilities as propose by the member of the party. All members (councilors) of political party should voice out their views and there was always a strong possibility that, meeting in a politically charged atmosphere and deprived of the guidance of their professional advisers, the members might find themselves becoming committed to resolutions, as perceived by Friend and Jesop (1971).

The Committee Meeting is an official occasion at which councilors and officers meet together, listen to the issues and recommendations from the officers, before translated into official decisions. Where the more strategic decisions were concerned, councilors seemed unable to address itself successfully to the task of making a balanced selection between alternatives. This tendency could be avoided by having a clear assessment on any particular contentious matters, based on 6 factors, as what have been debate and agreed at the pre-council meeting.

At the third level of decision-making process, all councilors of the parties met as a group prior to the monthly Full-Council Meeting. The task is to screen the minutes of the various committees, and also to formulate their tactics for any items to be dealt with on the council agenda (Friend and Jessop, 1971). The process will be much easier if the alternative and consensus have been develop and agreed at the first and the second level of the council's meeting, as what have been proposed under this new model. If the Full-Council Meeting unable to resolve any matters arises, or failed of having consensus results, then that particular minute is formally referred back to the Committee Meeting for further consideration and evaluation. The process of decision-making will goes through the same consequences process until the final and consensus results endorsed in the next Full-Council Meeting.

C. Accuracy of Decision

Under representative democracy, citizens elect their leaders, and the leaders are supposedly to make decisions that are best represent the interest of their constituents. In making such decisions, the leaders use two major criteria; i) what they think their constituents want them to do, and ii) what they (the representatives) think its best (Sewell & Coppock, 1977).

The study also looking to the question on how do councilors know that the decision they make is the most accurate one? Most of the councilors believe and depend on the formal and informal feedback systems, either from the council, their parties or the tax payers. Therefore the two-ways communication approach, either traditionally method such as informal meetings, dialogues or through internet facilities, will enable the public to responds or make an informed opinion or objection. This not only ensures better quality of participation but also to judge the accuracy of any decision made by councilors in achieving the stated objectives or target-groups.

Tuler and Webler (in Azizan, M., 2009) feel that it is important for the decision makers to provide adequate information and explanation while at the same time allowing feedback from the public. Many planning authorities in United Kingdom have taken the initiatives to improve the provision of planning information to the public. A good example would be the Nottinghamshire County Council which has a website dedicated to provide information about their planning proposals or programs.

VI CONCLUSION

The complexity of the decision-making process at local government level always causes the difficulties for councilors to make a rightful, objectively and effectively decisions. The existing model of decision-making did not provide them with a clear set of factors that guided them while debating any issues at the council meeting, and as a result, to some extent, we saw an inevitable outcome of the contrast between the complexity of choice and the limited options for acceptance or rejection of recommendations permitted by conventional committee procedures. Therefore the study, based on the theoretical conceptual of

decision-making process, successfully develop a set of decision-guideline consisting of 13 factors to be used by councilors while dealing with decision-making process.

ACKNOWLEDGMENT

Our sincere thanks goes to our colleagues in UUM and UiTM Kedah, Malaysia for whom we have great regard, and we wish to extend our warmest thanks to all those who have helped us with the creation of this paper.

REFERENCES

- Azizan, M. (2009). Public Participation in Tourism Planning: The Case of the Langkawi Islands, Doctor of Philosophy, Adelaide, Flinders University.
- Collins, C.A. (1978). Consideration on the Social Background and Motivations of Councillors, *Policy and Politics*, 6(4), 425-447.
- Copus, C. (2004). Party Politics and Local Government, U. Kingdom, Manchester University Press.
- Friend, J.K. & Jessop, W.N. (1971). *Local Government and Strategic Choice-An Operational Research Approach to the Process of Public Planning*. London, Tavistock Publications.
- Friend, J.K. & Jessop, W.N. (1969). *Local Government and Strategic Choice*, London, Tavistock Publications.
- Gregory, R. (1969). Local Elections and the Rule of Anticipated Reactions, *Political Studies*, 17(1), 31-47.
- J. Curtis, R. Jowell, L. Brook & A. Park (eds.) (1995). *British Social Attitudes: The Twelfth Report*, Aldershot, Dartmouth.
- Jones, G.W. (1973). The Functions and Organization of Councillors, *Public Administration*, 51(2), 135-146.
- Lee, J.M. (1963). *Social Leaders and Public Policy*, London, Oxford University Press.
- Newton, K. (1976). *Second City Politics: Democratic Process and Decision-Making in Birmingham*, London, Oxford University Press.
- Rao, N. (1993). *Managing Change: Councillors and the New Local Government*, York, Joseph Rowntree Foundation.
- Rees, A.M. and T.Smith (1964). *Town Councillors*, London, Action Society Trust.
- Sewell, W.R.D. & Coppock, J.T. (eds.). (1977). *Public Participation in Planning*, London, John Wiley & Sons.
- Young, K. & Rao, N. (1994). *Coming to Terms With Change? The Local Government Councillor in 1993*, York, Joseph Rowntree Foundation.

Amateur Radio Communication Technology Evolution and Issues in Malaysia

Azlee Johar, Wan Rozaini Sheik Osman, and Azizi Ab. Aziz

Universiti Utara Malaysia, Malaysia, azlee@ymail.com, {rozai174; azizi@uum.edu.my}

ABSTRACT

The adoption and use of wireless communication technology such as Amateur Radio Communication Technology (ARCT) have made the sharing and dissemination of information more easily achieved among community in particular situation. The evolution and issues in adoption of ARCT in Malaysia is discussed in this article. The study begins by making reference literature review which is related to ARCT. Qualitative research methodology is used to collect data, including participant involvement in Amateur Radio Community (ARC) program, casual interview among individual whose are related to ARCT and through review imperative article. The significance and passionately debated issues which are related to ARCT are also described in this article.

Keywords: Amateur radio, community, communication, evolution.

I. INTRODUCTION

Amateur Radio Communication Technology (ARCT) is a part of wireless communication technology (Laster, 2001; Cox, 2004; Haykin, 2005). The evolution of ARCT has not lag behind and become important in several developed countries such as Japan, USA, Holland, Canada and our neighboring country, Thailand.

However ARCT is still less use among community in Malaysia (Abdul Aziz, 2014; MARTS, 2015). The problem is until now there is still limited study to discuss the evolution and issues of ARCT in Malaysia. Therefore, this article is significant to highlight the evolution and issues regarding the ARCT in Malaysia.

II. METHODOLOGY

Qualitative research is to get responses through structured and casual interview to understand their perception of the issues at hand (Fontana & Frey, 2005; Chism, Douglas & Wayne, 2008). That means necessary to capture responses to conclude on their opinion about the evolution and issue of ARCT in Malaysia.

The methodology involved structured interview approach to ensure usability prior to get accurate information. Casual interviews with several individual among Amateur Radio Community (ARC) are done to obtain an issues related to the adoption of ARCT in their daily life. Respondents that have been

interviewed for the preliminary action to gain initial information are respondent from MCMC, ASTRA, MARES and related ARC entire of Malaysia.

According to Howell et al. (1997) and Blossfeld (2001) casual interview is a kind of interviews conducted without preparation or planning beforehand. Mishler (1991) and Rubin et al. (2011) stated that personality interviews are interviews with public figures were well-known, or it could be against those who considered the nature / habits / accomplishment that are unique, exciting to be appointed as news material. Theme, angle of study, outline and background of the problem should be harmonized to conduct interviews with respondents who have been in the study population. Thus the outline and background of the problem of this study is about issue in adoption the ARCT in Malaysia.

The number of respondents who were interviewed was not an issue because no specific method to determine the size of the sample to interview (Patton, 2002; Ismail, 2008; Connaway & Powell, 2010). Indeed, Litwin (1995), Forrest (2006) and Crawford & Irving (2009) asserted, the respondents interviewed should be have particular experiences, lessons, expertise and knowledge in a particular issue. Thus, respondents were selected based on their involvement in ARCT and involved the management of communication in Malaysia. In addition, the selection of respondents took into consideration the recommendations of the respondents interviewed before. This approach is recognized by Patton (2002), Ismail (2008) and Crawford & Irving (2009). Therefore, this study was interviewed eleven individuals were directly involved in the field of ARCT and communication management in Malaysia.

III. EVOLUTION OF ARCT IN MALAYSIA

Based on literature review, at the beginning, ARCT was a hobby (ARES, 2011; IARU, 2013; ARRL, 2014). It is commonly used in remote areas (Haring, 2003). ARCT is a wireless communication technology that using radio signals (wave), which is more effective than from mobile phones and Internet during emergency situation occurrence. Information is transmitted simultaneously to ARC in related area at the same time. This is the advantages and the unique of ARCT which are not have in other communication device (Laster, 2001, 2012; Pitt, 2014; ARRL, 2014).

Based on interview among related people, ARCT has begun transmitting the signal to the public in Malaysia since 1928. According to Abdul Aziz (2014) and MARTS (2015), during that time Malaysia is known as Malaya. Amongst the pioneers in ARCT during that time, is Richard Earle, who was active in radio transmission since 1928 to 1930.

In the early stages of ARCT evolution, the British government was not interested in the ARCT. Therefore the electrical companies, telecommunications personnel, radio fans and practitioners started to collect donation to establish ARCT network among the community who are interest in the broadcasting technology.

In 1921 Birch, the chief electrical engineer of the Johor state government experimented with a set of ARCT which are obtained from England and in 1923 formed the Johor Wireless Society. The influence of these efforts, Malaysia is one of the first British colonies began to adopt the ARCT. The first radio station was established in Kuala Lumpur is to share and disseminate the information among rubber estate workers and tin miners. Even though the experimental broadcasts among the Singapore ARC had begun earlier, the ARC in Kuala Lumpur is successful than Singapore. The Kuala Lumpur ARC started experimental work in November 1929 and officially commenced its regular broadcast service from the Selangor Club as base station (Agil & Hamzah, 2008; MARTS, 2015; MARES, 2015).

The British government encourages the ARC to broadcast the ARCT, using station located at Bukit Petaling Kuala Lumpur. The station was constructed in 1928 (McDaniel, 1994). The Kuala Lumpur Amateur Radio Society (KLARS) has begun to use the transmitter crystal controlled equipment named "Marconi S3A" through government channels in May 1931. They have successfully to transmit radio wave throughout the peninsula, parts of the Netherlands East Indies and Borneo. (McDaniel, 1994; Abd Latif, 2005). This is the uniqueness and greatness of the expertise of ARC of that era.

In 1933 temporary location was given to the amateurs when they were allocated space to construct a station at Bukit Petaling. The British government gave the permission to ARC to setup and establishes their own station after two years of operations (Raja Iskandar, 2005; MARTS, 2014). This is due to positive enhancements in the sharing and dissemination of information, especially on the plantations ARC and tin mines ARC.

ARCT progress is blocked during Japanese colonial era. Anyone who has ARCT equipment will be beheaded. Broadcasting facilities are only controlled by the Japanese army. They stayed for three years and

eight months. They used the radio wave to broadcast the propaganda. After Japan surrendered, the British military took over broadcasting and allowed ARC to share and disseminate information through the ARCT (Daniels, 1982; Asiah, 1994).

With the re-establishment of sharing and dissemination of information through ARCT, the alliances independence movement has emerged in Malaya at that time. The alliance movement to fight against the Malayan Union was proposed by the British government. The Malay community during that time has adopted and used the ARCT among the ARC to share and disseminate their effort to against the British government. On April 1, 1946, the day the Malayan Union was launched, the British government set up the Radio Malaya as the official department of broadcasting to defend their efforts against the establishment of the Malayan Union. In addition, they also feel threatened by the sharing and dissemination of information through ARCT among ARC and the public who were strongly demanding the independence from the British government. The main function of the official broadcasting until the country independence in 1957 was to help the government to control the social and political confusion that followed the war and the communist of 1948 until 1957 (Ramli & Othman, 2012). Girard (1992) and Raja Iskandar (2005) argued that the fact is ARC are the first who started transmitting their signals on High Frequencies (HF) before the birth of Radio Malaya but their roles were not mentioned in the radio broadcasting history.

Based on interviews among related peoples in ARCT field and identify related literature review, a table regarding ARCT evolution in Malaysia was constructed as in Table 1.

Table 1. ARCT Evolution

Years	Evolution of ARCT in Malaysia
1921	A.L Birch is a first person to transmit radio signal and set up ARCT which are obtained from London
1923	Johor Wireless Society, is the pioneer formation of ARC in Malaya
1928	The beginning ARCT used among the ARC in limited locations in Malaya
1929	Selangor Club is a base station for KLARC
1930	The radio wavelength in 75 meter band (4 MHz) is a best signal reception to the entire of country.
1932	The radio wavelength was upgraded to 48.92 meter band (6.125 MHz).
1933	British Company allocates permanent station to construct a transmission centre at Bukit Petaling.
1942	ARCT is blocked during Japanese colonial era until 1945.

1946	April 1, the opposition to Malayan Union was launched, the British government set up the Radio Malaya as channel to defend their efforts.
1948	ARCT is adopted to support the government to control the social and political confusion that followed the war and the communist of 1948 until 1957.
1957	ARCT is adopted to support the government to share and dissemination of information after independence day.
1980 to Present	The adoption and use of ARCT is only active among ARC and not widespread use. The adoption and use of ARCT in Malaysia is still lack and lagging compare to other country such as as Japan, USA, Holland, Canada and our neighboring country, Thailand.

IV. ARCT ISSUES IN MALAYSIA

Today Malaysian Communications and Multimedia Commission (MCMC) is encouraging community to use the ARCT as an alternative communications technology. Those who like to use the ARCT are required to take the examination which is prepared by MCMC to enable them to be registered practitioners of amateur radio. The adoption and use of ARCT is mainly to providing information and to assist the victim in emergency situation during disaster in a remote area that does not have good access to the telephone line or cellular phone (Mohd Aris, 2014; MART, 2014; MCMC, 2014).

Therefore the roles of non-governmental organizations like ARC are able to prepare, provide relief and support to government agencies in emergency situation during any the disasters. As example ARC in Japan helped to share and disseminates information to the public long before the public announcements were made by their government. The numbers of ARC in Japan are far higher compare to other country in the world (Fujiki, 2007; Nollet & Ohto, 2013). Unfortunately ARC counterpart in Malaysia, not only are few in numbers, are also not taken up by the government to support relief agencies in the emergency communications until this recent 2014 flood.

When severe flooding hit Kelantan and Terengganu on December 22, 2014, there was a major challenge to communication due to the failure of the telecommunication services. Existing communication during that situation was only through ARCT from the volunteer groups among ARC. Communication becomes more critical as the number of ARCT practitioner is limited (Ahmad, 2015).

The recent flood disaster in Malaysia highlighted several challenges and issues such as the need the

alternative communication like ARCT when their failure to maintain the current telecommunication due to the breakdown of the power station and electrical supply. The majority of the victim in the remote areas were not only stranded by the flood but were not able to communicate to ask for help, shelter and food (Ahmad, 2015).

Even adoption and use of ARCT as a hobby among ARC, their contributions and supports in emergency cases cannot be denied. For example, when the floods hit Johor in 2007, ARC has extended support in terms of online and mobile communication systems due to disruption and failure to operate. They have been a frontline in emergency communication in emergency situation during that time (Mohd Aris, 2014; Roszeta, 2014).

According to Bahari (2014), when huge floods hit Perlis and Kedah in 2010, ARC from ASTRA have been a frontline to support the Polis Diraja Malaysia (PDRM), Jabatan Kebajikan Masyarakat (JKM) and Badan Operasi Mencegah Bencana Alam (BOMBA) due to the failure of the entire communication system to operate.

Until July 2014, only 11,626 an Amateur Radio practitioner or HAM operators who are volunteers capable of giving support in the event of an emergency or natural disaster in Malaysia. Peninsular Malaysia has 9,919 individual registered and qualified ARCT operators, 1,487 operators in Sabah and 220 in Sarawak. In developed countries, ARCT widespread adopted mainly in emergencies but our country is still lagging behind in adoption the ARCT and still less exposed to the community (MARTS, 2014; Roszeta, 2014). This is issues that differentiate the developed countries against our country.

Furthermore our neighbours Thailand, has allowed their peoples to use ARCT since 1982. Currently, Thailand has more than 240,000 licensed amateurs' radio practitioner. Their government encourage the people to have experience in the field of wireless communication. In fact, ARCT can create economic opportunities such as services to construct a radio tower or antenna, product sales such as ARCT gadget, radio accessories and etc. Business activities involving ARCT gadget is greatly developed in Thailand (Pettit et al., 2014; Abdul Aziz, 2014).

ARC has brought many benefits to government, businesses, community and individuals. According to NSC (2012), Malaysian government encourages civilian to improve of individual who wants to be ARC, to get new knowledge, to be part of support in emergency situation. ARCs are both recipient and providers of information to alert each other as well as other stakeholders quickly. They can play a supportive role in early warning, search and rescue

and relief and support (Rashid & Zainal, 2013; Abdul Aziz, 2014).

Japan is the most popular in the adoption and use of ARCT and the highest number of ARC. ARC in Japan has been supported the relief agencies to save many lives in Japan tsunami 2011. Primarily to share and disseminate early warnings to the public before the tsunami occurred. Whereas the percentage of ARC in Indonesia is too low compared to its citizens, and maybe one of the main reasons why many lives were lost during 2004 tsunami, was the lack of information sharing and dissemination among relief agencies to the public (Yusuf, 2009; Koshimura et al., 2009; Izumi Aizu, 2011). Based on this perspective, we can look at the role and contribution of ARC as important to these countries.

ARCT are considered a highly appropriate option for developing countries, mainly in emergencies. However, researchers regard the adoption of ARCT is still lacking and lagging around the world and popularized as a hobby and a volunteer activity only (Laster, 2001; Haddow, 2009; Cuellar, 2012).

ARCT can play an important role as alternative communication in emergency situation. Thus, an effort to form collaboration with the experts in the field of ARCT in order to establish emergency communications in emergency situation during disaster is important (Mohd, 2011; Jailani, 2014). However, exposure of the importance of ARCT to the community in Malaysia is still lacking compared with neighbouring country such as Thailand (Pettit et al., 2014).

V. CONCLUSION

Furthermore ARCT is a contingency communication and significant as alternative communication in emergency situation when other communication device fails to operate.

As a conclusion, ARCT has lot of benefits may influence the stakeholders and role players in our country, but there are still a lot of issues abounded. Therefore need to carry out further study to understand the factors that influences ARC in the adoption of ARCT in Malaysia.

Until now, no specific study to explore this area. Many of the existing literature do not talk about the factors that influences ARC in the adoption of ARCT and implications to the country (Mohd, 2011; Rashid & Zainal, 2013; Ahmad, 2015). Thus in future a specific study in this area should be done to clarify and understand this issue in Malaysia. Therefore, the ARCT evolution and the issue were described and highlighted is significant to stakeholders and role players in related field in future. Hence, the

information aforementioned and hopefully provide a useful benefit to everyone.

ACKNOWLEDGMENT

Appreciation to ASTRA Malaysia and ASTRA Perlis because a lot of support and contribution in getting an information and respondents to conduct the interview.

REFERENCES

- Abd Latif, M. F. (2005) The Use of Electronic Media To Gratify Cognitive Needs Among The Semelai Heads Of Households In Tasek Bera, Pahang. Kuala Lumpur: Department of Communication UPM. Retrieved from http://psasir.upm.edu.my/5881/1/FBKM_2005_20 (1-24).pdf
- Abdul Aziz, M. N. (2014). Radio Amatur Malaysia - Sejarah yang dilupakan. (9M2AU). MARL - Malaysian Amateur Radio League.
- Agil, S. & A. Hamzah. (2008). "Self Regulatory Implementation and Practices in Malavsian Media Environment." A naner presented to the Sixth international Conference on New Directions in the Humanities. Fatih University, Istanbul, Turkey. July 15-18, 2008.
- Ahmad, S. (2015). Laporan Khas, Scoop & Bencana Banjir Berita TV RTM - Skuad Alfa Radio Amatur RTM. Kuala Lumpur: Unit Pasukan Khas / Bencana Radio Televisyen Malaysia.
- ARES. (2011). Amateur Radio Emergency Service. North Carolina Section Emergency Plan. Retrieved from <http://www.ncarrl.org/ncep.pdf>
- ARRL. (2014). Executive Committee Adopts Mobile Amateur Radio Operation Po. States News Service. Retrieved from <http://www.arrl.org/about-arrl>
- Asiah, S. (1994). The Histrocal Development of Malaysia Broadcasting in Malaysia (1930-1957) and Its Social and Politic Significants. Kuala Lumpur: Media Asia, Jilid 9.
- Bahari Taib. (2014). Seminar Radio Amatur- Komunikasi Berkesan Dalam Menghadapi Bencana Alam Di Malaysia dan Mesyuarat Agung ASTRA Kali Ke-17, 29 Mac 2014. UNIMAP Perlis.
- Blossfeld, H. P. (2001). *Techniques of event history modelling: New approaches to casual interview analysis*. Psychology Press.
- Chism, V.N., Douglas, E. & Wayne, H., W. (2008). *Qualitative research basics: A guide for engineering educators*. Retrieved from <http://cleerhub.org/resources/8>.
- Connaway, L & Powell, H., . (2010). *The Research Design: Qualitative, Quantitative and Mixed Methods Approaches*. 3rd Edition, Sage Publications, Inc., California, USA.
- Cox, J. B. (2004). The role of communication, technology, and cultural identity in repatriation adjustment. *International Journal of Intercultural Relations*, 28(3), 201-219.
- Crawford, J & Irving, M. (2009). *Qualitative research methods for the social sciences* (Vol. 5). Boston: Pearson.
- Cuellar, J. (2012). Reconsidering the Radio in Media Studies. USA: University of Southern California.
- Daniels, G. (1982). Japanese domestic radio and cinema propaganda, 1937-1945: an overview. *Historical Journal of Film, Radio and Television*, 2(2), 115-132.
- Fontana, A., & Frey, J. H. (2005). The interview: From neutral stance to political involvement. *The Sage handbook of qualitative research*, 3, 695-727.
- Forrest, C. (2006). *The SAGE handbook of qualitative research in casual interview*. Sage.
- Fujiki, S. (2007). Emergency notification device in radio communication apparatus. *U.S. Patent No. 7,310,500*. Washington, DC: U.S. Patent and Trademark Office.
- Girard, B. (1992). *A passion for radio: Radio waves and community* (Vol. 178). Black Rose Books Ltd.
- Goldsmith, A. (2005). *Wireless communications*. Cambridge university press. Retrieved from <https://books.google.com.my/books>
- Haddow, D. (2009). *Disaster Communication in the World. The mechanism of emergency communication* : USA. Heinemann Inc.

- Haring, K. (2003). The "Freer Men" of Ham Radio: How a Technical Hobby Provided Social and Spatial Distance. *Technology and Culture*, 44(4), 734-761.
- Haykin, S. (2005). Cognitive radio: brain-empowered wireless communications. *Selected Areas in Communications, IEEE Journal on*, 23(2), 201-220.
- Howell, P., Kapoor, A., & Rustin, L. (1997). The effects of formal and casual interview styles on stuttering incidence.
- IARU.(2013). Amateur Radio - 60th Anniversary of North Sea Floods. Retrieved from <http://www.iaru-r1.org/index.php/emergency-communications/1116-60th-anniversary-of-north-sea-floods>
- Ismail, S. (2005). *Kaedah penyelidikan dan panduan penulisan: esei, proposal, tesis*. Utusan Publications.
- Izumi Aizu. (2011).** *In The Aftermath of The Tsunami. Earthquake, tsunami and nuclear power station damage report. Japan:* Institute for Info Socionomics, Tama University.
- Jailani Johari (2014). Komunikasi Kecemasan Bagi Pengurusan Bencana. Simposium Antarabangsa Teknologi Telekomunikasi: Langkawi. SKMM.
- Koshimura, S., Oie, T., Yanagisawa, H., & Imamura, F. (2009). Developing fragility functions for tsunami damage estimation using numerical model and post-tsunami data from Banda Aceh, Indonesia. *Coastal Engineering Journal*, 51(03), 243-273.
- Laster, C.(2001).The beginner's handbook of amateur radio. Fourth Ed. New York: McGraw-Hill.
- Litwin, M. S. (1995). *How to measure survey reliability and validity* (Vol. 7). Sage Publications.
- MARES (2015). Penggunaan Radio Amatur Sebagai Komunikasi Luar Jangka. Kuala Lumpur : Malaysian Amateur Radio Emergency Services . Jalur Selatan Publication.
- MARTS (2014). Persatuan-Persatuan Radio Amatur Di Malaysia. Kuala Lumpur: Edaran Pusat.
- McDaniel, D. O. (1994). *Broadcasting in the Malay world: Radio, television, and video in Brunei, Indonesia, Malaysia, and Singapore*. Greenwood Publishing Group.
- MCMC. (2014). Amateur Radio in Malaysia. Malaysian Communications and Multimedia Commission. Retrieved from <https://skmm.gov.my>
- MCMC. (2014). Amateur Radio Role and Speciation. Retrieved from <https://skmm.gov.my>
- Mishler, E. G. (1991). *Research interviewing*. Harvard University Press.
- Mohd Aris Bernawi .(2014). Early Radio Amateur Activities in Malaysia. Kuala Lumpur: Malaysia Amateur Radio Transmitters' Society (MARTS).
- Mohd, E.T.(2011). Challenges of Media and Communication Issues: Implications for Malaysian Public Sectors. The Innovation Journal: The Public Sector Innovation Journal, Vol. 16(3), 2011, article 1.
- Muller, N. J. (2003). *Wireless A to Z: USA* McGraw-Hill. Retrieved from <http://imcs.dvfu.ru/lib.int/docs>
- Nollet, K. E., & Ohto, H. (2013). When all else fails: 21st century Amateur Radio as an emergency communications medium. *Transfusion and Apheresis Science*, 49(3), 422-427.
- NSC. (2012). National Disaster Management Organization (NDMO). Presented by Deputy Prime Minister of Malaysia Tan Sri Muhyiddin Yassin. Kuala Lumpur: Disaster Management Division.
- Patton, M. Q. (2005). *Qualitative research*. John Wiley & Sons, Ltd.
- Pettit, S., Beresford, A., Whiting, M., Banomyong, R., & Beresford, S. (2014). The 2004 Thailand tsunami and the April 2012 tsunami warning. In *Humanitarian Logistics: Meeting the Challenge of Preparing for and Responding to Disasters* (p. 129). Kogan Page Publishers
- Qiantori, A., Sutiono, A. B., Hariyanto, H., Suwa, H., & Ohta, T. (2012). An emergency medical communications system by low altitude platform at the early stages of a natural disaster in Indonesia. *Journal of medical systems*, 36(1), 41-52.
- Raja Iskandar .(2005). The History Of Radio And TV Broadcast In Malaysia -(9M2R1). Kuala Lumpur: Department of Communication UPM.
- Ramli, A. H., & Othman, M. R. (2012). Gagasan Malaysia Malaysia Wawasan PAP: Kesenambungan dan Penentangan pengaruh ideologi komunis dikalangan Orang Melayu, 1964-1969. *SARJANA*,27(1).
- Rashid, S & Zainal. F.(2013) . Wireless Technology Communication of Amateur Radio in Malaysia. Convention and Workshop of Amateur Radio Road Map in Malaysia:UKM Bangi. The national association for HAM radio in Malaysia – MARL. Retrieved from <http://www.jasra.org.my/>
- Roszeta Kassim (2014). Malaysia Miliki Lebih 11626 Pengendali Radio Amatur. Ketua Suruhanjaya Komunikasi dan Multimedia (SKMM) Wilayah Selatan Melaka: KKMM.
- Rubin, H. J., & Rubin, I. S. (2011). *Qualitative interviewing: The art of hearing data*. Sage.
- Yusuf, I.(2009). *Mengenang Mangsa Bencana Gempa Bumi dan Tsunami di Aceh 26 Desember 2004*. Indonesia : Provinsi NAD.

A Framework for Correcting Human Motion Alignment for Traditional Dance Training Using Augmented Reality

Javid Iqbal, and Manjit Singh Sidhu

Universiti Tenaga Nasional, Malaysia, manjavid@gmail.com

ABSTRACT

This paper presents a framework for motion capture analysis for dance learning technology using Microsoft Kinect V2. The proposed technology utilizes motion detection, emotion analysis, coordination analysis and interactive feedback techniques for a particular dance style selected by the trainee. This motion capture system solves the heterogeneity of the existing dance learning system and hence provides robustness. The analysis of the proposed work is carried out using query techniques and heuristic evaluation. The Microsoft Kinect V2 embedded with Augmented Reality (AR) technology is explored to demonstrate the recognition accuracy of the proposed framework.

Keywords: Microsoft Kinect V2, Augmented Reality, Dance, learning technology.

I INTRODUCTION

Dance is an ethereal art since it depends on the motion of performers gestures. Dance can communicate various messages according to the context, and focus on aesthetical aspects (classical, contemporary, western dance) traditional aspects (folk, cultural dances) and spiritual aspects and so on. The cultural dances are strongly connected to the traditional heritage that shapes the identity of a particular place. These dance styles are explored and learnt through small group of people who get together to practice and gain expertise on these traditional dances. Hence, know-how aspects of these dance forms face a major risk factor where few elements of this intangible cultural heritage could die out if not preserved and safeguarded for the future generations.

Information technology plays a vital role for development of platforms that are employed for analysis, capturing and modeling of such extensive dance interactions and can eventually contribute towards significant transformation of artistic knowledge for next generation. The main drawback lies in the precise recognition of human body movements. Nowadays, the evolution of motion capture technology that has led to the innovation of Microsoft Kinect sensors have advantages over earlier systems to make more precise measurements with wide array of sensing capabilities, availability of processing power to achieve complex data

interpretations and enhance the flexibility of dance learning technology.

A. Dance Technology

The advancement in technology has paved way for easy dance education. Computer Vision (CV) and Augmented Reality (AR) are the recent trends in dance education. There are more than 100 different dance styles in world. Is it possible for an individual to learn different dance styles? Yes, it is possible but the learner must find different dance professionals or choreographers to learn different dance styles. The dance learner must make sure he goes to different dance schools to learn different dance styles, it is also mandatory that the learner can learn the specific dance style from the professional only during scheduled time.

AR technology steps in to overcome all the limitations in traditional dance learning. Technology has made available numerous ways to search for information or video to make self learning easier, but the major drawback is that the online websites do not provide interactive feedback and inspiration to the learners by which the learning process becomes unprofessional.

To learn a subject we need books to learn a specific dance style we need a professional dancer or choreographers. We propose a system using Kinect V2 which bring in the choreographer for in house and class room training with interactive feedback and comments.

II RELATED WORK

Computer vision and motion sensing technology have enabled the users to actively, physically and mechanically interact with the digital environment in various ways. The hybrid combinations of traditional art forms and advanced CV technology have made the authors in the last decade to drive out the AR based dance learning system. Researches provide an updated interactive performance system for floor and aerial dance that controls visual and sonic aspects of the presentation through Microsoft Kinect camera. Improvised gesture recognition and tracking system called Action Graph (AG) is described in this article, which has the capability of capturing incoming gestures in an unsupervised way & enables mapping between input gestures to desired rendering functionalities (Wang, 2015). In this paper, authors have presented five interactions used in augmenting an improvised dance show. The system that allows those

interactions is composed of several interconnected modules (Clay et al., 2012). The researchers have described Cha learn gesture data set that is user dependent, small vocabulary and one-shot learning using Kinect camera (Guyon et al., 2014). Authors present a simple and computationally efficient framework for 3D dance basic motion recognition based on syntactic pattern recognition (Heryadi et al., 2013). In this paper, authors measure the desirability of the tool for describing and reproducing Thai dance. The survey experiment was conducted on over 200 students and teachers in four well-known schools in Thai dances. The results show that about 70% of subjects think that the software has usability, desirability, creativity and fun, (Choensawat et al., 2013). The following Table 1 illustrates the research findings and drawbacks of the existing systems in AR based dance learning technology.

Table 1. Summary of drawbacks and research findings for AR based dance learning technology

Year	Author	Techniques / methods used	Drawbacks	Research findings
2015	Dubrov and Wang	MS Kinect, Action Graph (AG), Multiple IR Markers.	The authors have not focused on errors and feedback.	There is no consideration of interactive feedback and more number of trainees.
2014	Guyon et al.	Small vocabulary, fixed camera, one-shot learning, and data include 54,000 hand and arm gestures recorded with an RGB-D Kinect camera	Different gestures are learnt no dance is considered and no feedback is taken into consideration.	Different dance styles are necessary to master dance.
2013	Heryadi, Fauzy, and Aryanturly	Syntactic pattern recognition, Stochastic Regular Grammar (SRG)	Dance basic motion analysis is done further work must be done for dance motion analysis. No feedback is given	Only body motions are considered. Dance motion analysis is to be examined.
2013	Choensawat, Sookhanaphiborn, and Kijklum	Labanotation, LabanEditor, Thai Dance Notation System.	Authors focus only on Thai dance style. No feedback or comments given from the system	Only one dance style is focused.
2013	Anderson et al. 2013	Half-silvered mirrors (HSMs), Microsoft Kinect	The Kinect has difficulty tracking movements that cause large amounts of occlusions. Improvements in sensing technology will open new domains of training.	Recorded data is used for training the users and problems faced by large amount of occlusion.
2013	Kanamoto et al.	Augmented Practice Mirror (APM), Radish the motion tracking system	Authors focus on velocity and acceleration visualization method for APM, for learner's further understanding of teacher's motion.	Other parameters such as error and feedback are to be considered.

The authors have discussed a novel system YouMove that allows users to record and learn physical movement sequences. The Kinect-based recording system is designed to be simple, allowing anyone to create and share training content, some of the screen shots are shown in Figure 1. The corresponding training system uses recorded data to train the user using a large-scale AR mirror. The system trains the user through a series of stages that gradually reduce the user's reliance on guidance and feedback. This

also discusses the design and implementation of YouMove and its interactive mirror. The authors have presented a user study in which YouMove was shown to improve learning and short-term retention by a factor of 2 compared to a traditional video demonstration. While the presented implementation uses a half-silvered mirror as a display, the software could also run as a traditional video-based AR system (Anderson et al., 2013). The Kinect has difficulty tracking movements that cause large amounts of occlusions. This would be more accessible to users, but does not provide the real-time feedback that the mirror does. It would be interesting to better understand any learning difference between a mirror and video based system on various devices (large screen, small screen, etc.). The addition of social features and richer inclusions of gaming technologies could also greatly help YouMove. The paper presents an algorithm for real-time body motion analysis for dance pattern recognition by use of a dynamic stereo vision sensor and Hidden Markovian Method (HMM) (Kohn et al., 2012).

Authors had illustrated a framework to develop a digital bharathanatiam interaction (Majumdar, 2012). A novel approach is proposed for generating dance performance based on music similarity (Lee et al., 2012). The research had presented an automatic dance lesson generation system which is suitable in a learning-by-mimicking scenario where the learning objects can be represented as multi-attribute time series data (Yang et al., 2012). Authors have described a novel framework for music-driven dance choreography synthesis and animation. For this purpose, authors construct a many-to-many statistical mapping from musical measures to dance figures based on the correlations between dance figures and musical measures as well as the correlations between successive dance figures in terms of figure-to-figure transition probabilities. Then use this mapping to synthesize a music-driven sequence of dance figure labels via a constraint based dynamic programming procedure. With the help of exchangeable figures notion, the proposed framework is able to yield a variety of different dance figure sequences (Ofli et al., 2012).

This paper has provided an overview of the contextual issues that surrounds the design of two interactive applications for building awareness of ICH in museums. The agenda is to design a serious gaming environment for visitors in which to learn indigenous dance inside the museum (Khan and de Byl, 2012). This study makes a body model for education of dance how lively a dance trainer moves his/her body so that the dance student can learn dance from the dance trainer who is in the distant place through communication line in virtual dance studio (Takai, 2012). The authors have proposed a new dance

training system based on motion capture and virtual reality technologies (Chan et al., 2011). Authors proposed a visualization method of the velocity and acceleration of the teacher's motion for the learner to understand it more easily and Clearly (Kuramoto et al., 2013). The research analysis done for dance learning with or without interactive feedback shows that there is no consideration for more number of users in literature till date as depicted in Table 2.

Table 2. Summarization of dance learning technology

Year	Author	Augmented (Yes/ No)	Type of art	Interactive feedback	No of trainees
2015	Dubrov and Wang	Yes	Floor and Aerial Dance	No	1
2014	Guyon et al.	No	Gesture	No	1
2013	Heryadi, Fanany, and Arymurthy	No	Basic Dance	No	1
2013	Choensawat, Sookkhanaphibarn, and Kijkhun	No	Thai Dance	No	1
2013	Anderson et al.	Yes	Dance	Yes	1
2013	Kuramoto et al.	Yes	Physical motion	No	1
2012	Kohn, Nowakowska, and Belbachir	No	Dance pattern	No	1
2012	Majumdar.	No	Bharatanatyam dance	No	1
2012	Lee, Lee, and Park.	No	Dance	No	1
2012	Yang et al.	No	Dance	No	1
2012	Khan and de Byl.	Yes	Indigenous dance	No	1
2012	Takai.	No	dance	No	1
2012	Clay et al.	Yes	Ballet Dance	Yes	1
2012	Ofii et al.	No	Dance	No	1
2011	Chan et al.	No	Dance	Yes	1



Figure 1. AR based dance learning using Kinect

III SYSTEM DESIGN

The agenda of the research is to use full body interaction for two to six numbers of trainees with interactive feedback. The hardware and the software of the system are comprises of Microsoft Kinect V2 which generates the skeletal image of the trainee who stands in front of Kinect V2. Kinect V2 has the

maximum capabilities of tracking six numbers of trainees with 26 body joints per trainee. Kinect V2 supports USB 3.0 since the number of process done by the kinect must be transferred to a system for processing with optimum transfer speed which is obtained only with USB 3.0 and not with USB 2.0. The architecture of the system design/ Kinect SDK is shown in Figure 2.

Kinect for Windows can work with windows 8.1 and windows 10. Microsoft visual studio is used for developing web application and web services using coding languages like C# and XAML codes for Kinect. To use the audio control that is to get the interactive feedback Kinect audio control SDK must be installed.

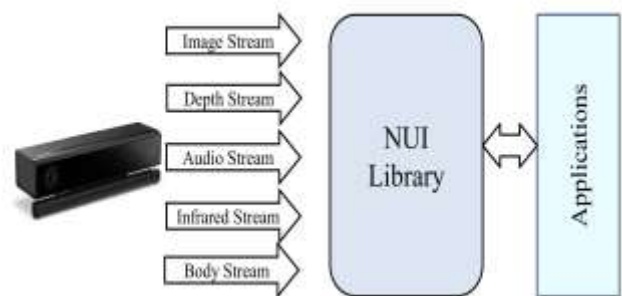

Figure 2. System design

A. Interface/ Model

The interface of the system is designed in such a way that even a beginner can interact with the system. The hand gesture reorganization in Kinect v2 is used as interaction platform for the trainee and the trainers. With the use of hand gesture reorganization the trainee need not move from their location to the system to interact. The trainee must raise their hands to start the interaction with the system, once the hand is recognized by the system the hand icon will appear on the screen after which the trainee can scroll, click and select the option available on the screen with his hands. A screen shot of the hand gesture reorganization is given in Figure 3.

B. Interaction

There are two interactions involved in the system they are Trainee interacting with the system and the system giving feedback to the trainee.



Figure 3. Hand gesture recognition.

Trainee interacting with the system: The trainee interacting with the system is uses friendly that even a beginner can interact with the menus and options available. Some of the menus available are different types of dance styles available, our research mainly focuses on different dance styles available in India, some of the famous dance styles are Bharathanatyam, kathakali, Oddisi, Bhangra and many more.

The trainee can choose any dance forms available in the main screen by clicking on a specific dance style using hand gesture reorganization the menu jumps into the selected submenu where the trainee will have a brief description about the selected dance and what level of dance he/ she wants to learn with the system.

Different levels of dance are Beginner, Intermediate and Advanced. There are three different levels of dances available for the learner to choose from according to the selected dance level the training starts.

System giving feedback to the trainee: After selecting the dance style the trainee can choose different steps available in the database. Once the level and the steps are selected, the skeletal image of the selected dance will be projected on the screen the trainee who wants to learn dance must match the skeleton movement on the screen with the skeletal of their own. If there is 80 % match in the movement then the next step is continued. If there is a mismatch in the steps performed then the system will indicate the error with a balloon on the top of the trainee skeleton stating there is a miss match in the steps kindly move your leg to the skeleton on the screen and also a voice response telling the same to the trainee. Once the step is attained 80% accuracy there will be a motivating feedback from the system “Excellent we shall move on to the next step”. Thus the proposed system helps the trainee with interactive feedback and motivating comments.

IV PROPOSED FRAMEWORK

The architecture of the proposed system consists of three major components training using Kinect, Motion capture and performance evaluation. Figure 4 shows

the relation between each of the components. The students dance movements are captured by Kinect V2 and are detected for subsequent correctness of the motion using the motion detector. The motion detector uses motion analysis method and motion capture technology. The emotion expressed by the dancers are analyzed and matched with the data in the data base through the emotion analyzer using emotion analysis technology. The interactive feedback component provides feedback and comments to the student. The comments and the feedback given to the trainers are displayed using a balloon text on the screen and a voice reading the same. The performance evaluation compares the movements performed by the student based on the repetition and provides individual scores for every dance step performed. The computing devices are used to visualize the overall movements done by the student by a physical teacher either at the same place or from a remote location.

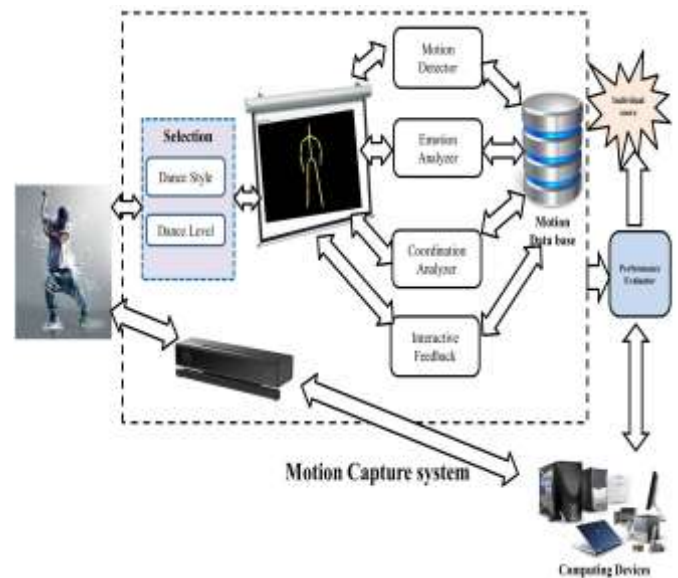

Figure 4. Proposed Framework

V ANALYSIS METHODOLOGY

The analysis of this research deals with two major aspects firstly the design of the system is evaluated followed by evaluation through user participation and query techniques. The trainees of the proposed dance learning system are divided into two main groups namely control group and study group. Control group is defined as a group of trainees who are expertise in dance skills with the help of trainers, whereas study group consists of trainees who are trained with kinect V2. Each of these groups consists of 5 batches where each batch has 6 numbers of students. The different criteria upon which design analysis and usability test are done includes are group, dance style/type, place/ country users opinion about learning dance / physical activity and users activity of interest.

The evaluation of system design is done using cognitive walkthrough method, heuristic evaluation and review based evaluation. The study in control group and study group are trained intensively for one month and then the mode of training is interchanged between the groups to evaluate the impact of training by dance experts.

In this way the performance, repeatability precision and efficiency of the dance is evaluated. Evaluation through user's participation is done based upon queries techniques such as interview and survey. The users those who have expertise their dance skills based upon the proposed dance learning system are interviewed and a detailed survey is conducted as how well they have been trained. The performance analysis of control group and study group is done using correlation analysis to gain reliability of the proposed system and the results will be published in the next subsequent paper.

VI CONCLUSION

The significant contribution of AR towards learning technology in computer vision has led many researchers to adopt AR as one of the most promising and distinctive direction for computer vision education. The users can experience the effect of individual in- house training as well as group learning for personal motivation and enhancement of artistic skills. This paper describes a framework for dance training with interactive feedback. The advantage of AR in educational sector paves way to visualize digital media, in- depth observation of subjects involved and possibilities to assess the virtual information according to the users need. The evolution of Microsoft Kinect makes AR based dance learning more fun- filled, user-friendly, self-motivating and responsive experience. It can further be concluded that traditional and cultural dance forms can be preserved and safeguarded to transform it to the future generations with the help of CV technology.

REFERENCES

- Anderson, Fraser, Tovi Grossman, Justin Matejka, and George Fitzmaurice. (2013). "YouMove: Enhancing Movement Training with an Augmented Reality Mirror." *Proceedings of the 26th annual ACM symposium on User interface software and technology - UIST '13*: 311–20. <http://dl.acm.org/citation.cfm?id=2501988.2502045>.
- Chan, J C P, H Leung, J K T Tang, and T Komura. (2011). "A Virtual Reality Dance Training System Using Motion Capture Technology." *IEEE Transactions on Learning Technologies* 4(2): 187–95.
- Choensawat, Worawat, Kingkarn Sookhanaphibarn, and Chommanad Kijkhun. (2013). "Desirability of a Teaching and Learning Tool for Thai Dance Body Motion." : 171–79.
- Clay, Alexis et al. (2012). "Interactions and Systems for Augmenting a Live Dance Performance." *11th IEEE International Symposium on Mixed and Augmented Reality 2012 - Arts, Media, and Humanities Papers, ISMAR-AMH 2012*: 29–38.
- Fan, Rukun, Songhua Xu, and Weidong Geng. (2012). "Example-Based Automatic Music-Driven Conventional Dance Motion Synthesis." *IEEE transactions on visualization and computer graphics* 18(3): 501–15. <http://www.ncbi.nlm.nih.gov/pubmed/21519104>.
- Guyon, Isabelle, Vassilis Athitsos, Pat Jangyodsuk, and Hugo Jair Escalante. (2014). "The ChaLearn Gesture Dataset (CGD 2011)." *Machine Vision and Applications* (Cgd): 1–23.
- Heryadi, Y, MI Fanany, and AM Arymurthy. (2013). "Stochastic Regular Grammar-Based Learning for Basic Dance Motion Recognition." *Cloud2.Snappages.Com*: 978–79. [http://cloud2.snappages.com/b887f6216920e33921eb3600dca196648e63c23d/767-SRG for Dance Basic Dance Motion Recognition.pdf](http://cloud2.snappages.com/b887f6216920e33921eb3600dca196648e63c23d/767-SRG%20for%20Dance%20Basic%20Dance%20Motion%20Recognition.pdf).
- Khan, Muqeem, and Penny de Byl. (2012). "Creating Tangible Cultural Learning Opportunities for Indigenous Dance with Motion Detecting Technologies." *2012 IEEE International Games Innovation Conference*: 1–3. <http://ieeexplore.ieee.org/lpdocs/epic03/wrapper.htm?arnumber=6329834>.
- Kohn, Bernhard, Aneta Nowakowska, and Ahmed Nabil Belbachir. (2012). "Real-Time Body Motion Analysis For Dance Pattern Recognition." *2012 IEEE Computer Society Conference on Computer Vision and Pattern Recognition Workshops*: 48–53. <http://ieeexplore.ieee.org/lpdocs/epic03/wrapper.htm?arnumber=6238894>.
- Kuramoto, Itaru et al. (2013). "Visualizing Velocity and Acceleration on Augmented Practice Mirror Self-Learning Support System of Physical Motion." *2013 Second IIAI International Conference on Advanced Applied Informatics*: 365–68. <http://ieeexplore.ieee.org/lpdocs/epic03/wrapper.htm?arnumber=6630375>.
- Lee, Minho, Kyogu Lee, and Jaehung Park. (2012). "Music Similarity-Based Approach to Generating Dance Motion Sequence." *Multimedia Tools and Applications* 62(3): 895–912. <http://link.springer.com/10.1007/s11042-012-1288-5>.
- Majumdar, Rwitajit. (2012). "Framework for Teaching Bharatanatyam through Digital Medium." : 241–42.
- Ofli, Ferda, Engin Erzin, Yücel Yemez, and a. Murat Tekalp. (2012). "Learn2Dance: Learning Statistical Music-to-Dance Mappings for Choreography Synthesis." *IEEE Transactions on Multimedia* 14(3 PART 2): 747–59.
- Takai, Miwa. (2012). "Production of Body Model for Education of Dance by Measurement Active Quantity." *The 1st IEEE Global Conference on Consumer Electronics 2012*: 212–16. <http://ieeexplore.ieee.org/lpdocs/epic03/wrapper.htm?arnumber=6379584>.
- Wang, Cheng-i. (2015). "Free-Body Gesture Tracking and Augmented Reality Improvisation for Floor and Aerial Dance Free-Body Gesture Tracking and Augmented Reality." (October).
- Yang, Yang, Howard Leung, Lihua Yue, and Liguang Deng. (2012). "Automatic Dance Lesson Generation." *IEEE Transactions on Learning Technologies* 5(3): 191–98.

Using Hybrid Technique: the Integration of Data Analytics and Queuing Theory for Average Service Time Estimation at Immigration Service, Suvarnabhumi Airport

Todsanai Chumwatana, and Ichayaporn Chuaychoo

Rangsit University, Thailand, {todsanai.c; ichayaporn.c}@rsu.ac.th

ABSTRACT

In the past few years, Thai tourism industry has become one of the big markets in the world that makes the number of air passenger has growth rapidly. The survey shows that 15,883,928 passengers arrived at Suvarnabhumi international airport, Thailand in 2015 which increase around 11% every year. Due to this reason, the airport needs to seek for effective strategies to operate an immigration service in order to avoid long waiting time. The effective immigration operation actually can gain passenger satisfaction. In addition, the fast immigration process provides the significant benefit for businesses in the airport because short immigration waiting time would be able to increase the purchase amount in shopping area. This paper aims to propose the hybrid method, the integration of data analytics and queuing theory, for average service time estimation at the immigration unit, Suvarnabhumi airport. From the experimental study, the proposed technique can estimate the average service time, server utilization and average number of passengers in a queue based on the statistic of arrival passengers. The result shows that the number of opened counter and month are the factors to provide different results.

Keywords: Queuing theory, data analytics, immigration, airport.

I INTRODUCTION

Since Suvarnabhumi international airport has become one of the biggest hub in ASEAN countries, airport has been facing the rapid growth of the number of arrival passengers in the past few year. This makes an immigration has become a challenging task. Waiting in the long queue at the immigration service is no one's favorite activity. The passenger's experience can be stressful and time consuming. From the unofficial data (refer to <http://tastythailand.com/how-long-does-it-take-to-get-through-suvarnabhumi-airport-bangkok-immigration>), one passenger has to spend at least 15 – 30 minutes in the queue to finish the immigration process. From the observation at arrival area, the airport provides immigration counters in 3 zones, totally 130 counters. In practical way, the average

number of active immigration counters is only 15 for each zone which totally 45 counters opened for serving the passengers. Moreover, a traditional queuing system has been used at immigration service, which makes the service time much longer than using a single line queuing system as shown in the following figure.

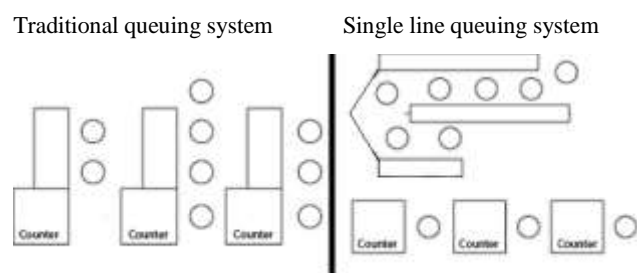

Figure 1. Two different queuing systems

Consequently, airport needs to seek an efficient, strategic approach to manage queues that aims for a balance between service to passengers. Many questions have to be taken into serious issues such as how long the service will take, how long does a passenger expect to wait in the queue before they are served, what is the average length of the queue and what is the expected utilisation of the serving counter? By using an effective queuing system, airport will be able to gain many benefits. Reducing the time spent at immigration unit will increase purchasing volume in shopping and service areas. In addition, the good queuing system will also gain passenger satisfaction. This paper aims to propose the hybrid method, the integration of data analytics and queuing theory, to reveal the performance of queuing system at the immigration service, Suvarnabhumi international airport. M/M/C queuing model (single line queuing system with multi-servers) is applied in the proposed technique. This model shows many benefits over the current traditional queuing system. Before the proposed technique will be described, some related works have been studies in the following section.

II RELATED WORKS

In 1908, Agner K. Erlang identified that the number of telephone conversations and telephone holding time fit into Poisson distribution and exponentially distributed (Agner, 1908). This was the beginning of the study of queuing theory. At present, queuing theory has been widely adopted to many businesses as the queue is a common every-day experience. Queuing theory is the mathematical study of waiting lines, or queues (Sundarapandian, 2009). In queuing theory, a model is constructed so that queue lengths and waiting time can be predicted.

Queuing models can be divided into many types: M/M/C, M/M/1, M/M/C/K, M/M/1/K, M/G/1, M/G/∞, G/M/1, M/Er/1 etc, (Adan & Jacque, 2015). Different models are suitable for different queuing system depending on the system characteristic. This theory is a well-known model applied for dealing the problems which involve queuing in both visible and invisible waiting line, such as, customers waiting for service at supermarket, bank, or restaurant including users waiting for a response from ATM machine or call center. In order to serve customers fast and efficiently, one of many solutions applied in many service organizations is providing adequate manpower to handle customers in the waiting line. Hence, it is essential that service providers can seek the effective way to predict the number of customers and prepare the sufficient number of employee to serve the customers so that each customer does not have to wait too long in the queue. In airport operations, waiting times also affect customer satisfaction significantly. Reducing waiting time would increase service quality and customer satisfaction.

Normally, many service organizations improve the performance of service delivery process by either increasing the number of service providers or reducing processing times. However, the number of staff that can reduce the waiting time needs to match with number of customers. So, the prediction of number of arrival customers is also a key for manpower planning. If service organizations can forecast the amount of arrival customers in each period of time, they will be able to allocate sufficient staff to provide services efficiently. The study of patterns of customers can be done in many ways. Simply, historical data of customers can be collected and analyzed to understand the behaviors and patterns of customers. From those statistical data, the organization can easily see the customer patterns and predict the future trends.

In the present, as Information technology plays an important role in almost every part of business process, data analytics is one of the techniques widely used in many fields of businesses, for example, customer churn prediction in telecommunication industry (Yan, Wolniewicz, Dodier, 2004), demand

forecasting in supply chains (Carbonneau, Yahidov, Laframboise, 2008) and prediction of customer demand in energy market (Parra & Kiekintveld, 2013). Likewise, for airport business, the passenger forecast is crucial issue because the passenger congestion at each service points including check-in counters, security checkpoints and immigration counters is a main problem of many international airports which is affecting passenger satisfaction towards airport itself.

In the study of De Lange (2013) which realized the problem of increasing passenger traffic volume at a large international airport located in Western Europe and proposed to use virtual queuing help shifting the demand of passengers at the security checkpoints from the peak periods to idle periods, they found that the application of virtual queuing can reduce waiting time and operating costs. However, there are still some constraints of using virtual queuing at the airport because passengers' schedule is not flexible but fixed by the departure or arrival time of their flights. Thus, to provide more accurate results of improving the service time at the airport, the data used in this study is the statistical data of arrival passengers. Then, data analytics is applied to predict the number of arrival passengers at each period of time and the queuing theory is also integrated to analyze the estimated service time. The proposed methodology will be clearly discussed in the following section.

III USING HYBRID METHOD FOR AVERAGE SERVICE TIME ESTIMATION AT IMMIGRATION UNIT

In this section, the proposed technique that integrated two methodologies is described. This technique aims to improve the service time for immigration at Suvarnabhumi international airport by applying queuing theory to statistics of arrival passengers. Therefore, the proposed method consists of two main steps: **1)** a process of analysis the previous arrival passenger data, and **2)** a process of queuing analytics as shown in the following Figure 2.

From figure 2, the arrival passenger data analytics is regarded as the first process in the proposed technique. To perform this step, arrival passenger data needs to be collected from department of tourism website (refer to <http://www.tourism.go.th/home/listcategory/11/217>). Then, the statistical method is applied to entire data to analysis the average number of passengers in different months as shown in figure 3.

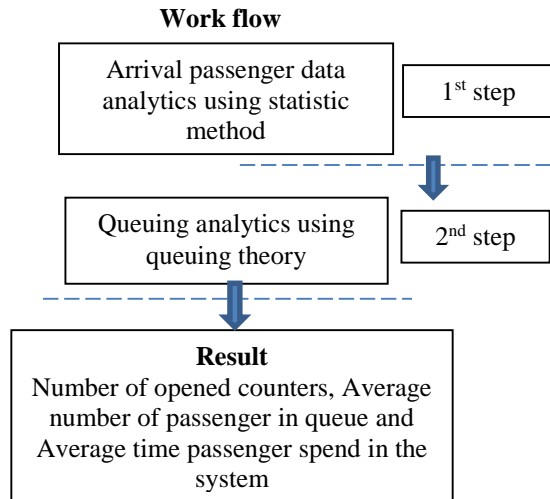

Figure 2. System Architecture



Figure 3. Statistics of arrival passengers.

The extracted average number of passengers in different months will then be used as an input data for queuing analytics process in next step. In this research, the data is categorized by month because different months have different traffic rates. However, to use the queuing theory in the next step, three variables are needed as an input data: C = number of active counters, λ = Arrival rate, and μ = Service rate. From observation at Suvarnabhumi airport, the average number of active counters opened at immigration service is around 45 which each counter normally spent around one minute for one passenger. These three variable will lead to the next process. In the second step, the M/M/C queuing model, known as multi-server queuing model (Harrison & Naresh, 1992), is applied to three extracted variables from the previous process. This model is used in this research because it matches with the characteristic of immigration unit as depicted in the following figure.

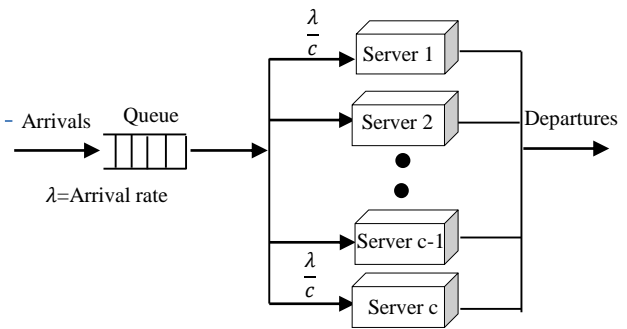

Figure 4. Characteristic of queuing system at immigration unit applied by M/M/C model.

The main characteristics of thus M/M/C model can be described by using the following formula.

$$L_q = \left[\frac{1}{(c-1)!} \left(\frac{\lambda}{\mu} \right)^c \frac{\lambda \mu}{(c\mu - \lambda)^2} \right] P_0$$

$$L_s = L_q + \frac{\lambda}{\mu}$$

$$W_q = \frac{L_q}{\lambda}$$

$$W_s = \frac{L_s}{\lambda}$$

$$\rho = \frac{\lambda}{c\mu}$$

Where:

c = Number of server (Counter)

λ = Arrival rate

μ = Service rate

ρ = Average server utilization

L_q = Average number of passengers in the queue

L_s = Average number of passenger in the system

W_q = Average waiting time in the queue

W_s = Average service time in the system

For further understanding, the example of using proposed technique with arrival passenger data in November 2015 is revealed. In Suvarnabhumi international airport, November has been regarded as the busy month for airline business. The immigration service at Suvarnabhumi international airport is opened 24 hours a day, 7 days a week. The total number of arrival passengers in November is 1,362,749. So, a total arrival rate or λ is around 1,893 per hour. From observation at the airport, the average number of counters or C opened at immigration service is around 45 which each counter normally spends around one minute for one passenger. This makes service rate or μ is around 60 passengers per hour. Consequently, final analysis report is founded in the following.

$$L_s = \left[\frac{1}{(c-1)!} \left(\frac{\lambda}{\mu} \right)^c \frac{\lambda \mu}{(c\mu - \lambda)^2} \right] P_0 = 0.0371$$

$$L_s - L_q = \frac{\lambda}{\mu} = 31.58$$

$$L_q = \frac{c\mu}{c\mu - \lambda}$$

$$W_s = \frac{L_s}{\lambda} = 0.0012$$

$$W_q = \frac{L_q}{\lambda} = 1.0012$$

$$\rho = \frac{\lambda}{c\mu} = 0.7011$$

From the final report, the most important issue that airport needs to know is three values: average service time in the system (period from passenger enter a queue until service finished) or W_s , average number of passengers in the queue or L_q and number of counters opened or C . As noticed in this report, this provides significant benefit for airport to gain more passenger purchase volume and increase passenger satisfaction if airport applies the proposed technique to queuing system. In addition, airport is also able to plan appropriate manpower by identifying suitable number of service counters.

IV EXPERIMENTAL STUDIES

In this section, an experiment for analyzing the average service time passenger spent in the system and number of counter opened is presented. Statistics of arrival passenger data were used as an input in the experimental study. Data used is collected from department of tourism website (refer to <http://www.tourism.go.th/home/listcategory/11/217>). The following table shows some examples of statistics of arrival passenger data used in the experiment.

Table 1. A statistics of arrival passenger data
Number of arrival passengers

Nationality	Jan-55	Feb-55	...	Nov-58
East Asia	492,817	497,469	...	704,362
Europe	470,717	434,910	...	383,056
The Americas	86,408	76,421	...	87,420
South Asia	79,951	83,012	...	98,154
Oceania	55,334	45,764	...	40,413
Middle East	42,335	41,574	...	40,641
Africa	8,456	7,687	...	8,703
Grand Total	1,236,018	1,186,837	...	1,362,749

In order to determine whether the proposed method is appropriate for analyzing the average service time passenger spent in the system and number of counters need to be opened for effective immigration service, the experiment was studied in two points of view: 1) the appropriate number of counters need to be served

at immigration unit and 2) the average service time passenger spent in the system in different months.

In the first point of view, this paper aims to identify the appropriate number of counters needed to be served at immigration unit. Arrival passenger data in November is used to be the case study. A total arrival rate or λ is around 1,893 per hour and each counter normally spends around one minute for one passenger. Different number of servers or C ranged from 32 to 55 will be tested in the experiment in order to find the appropriate number of opened counters as shown in the following.

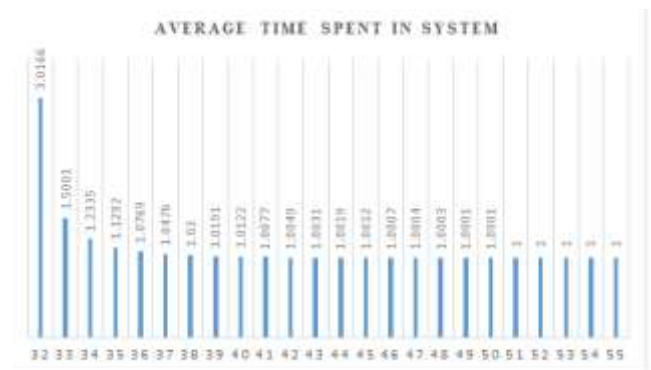

Figure 5. Average time passengers spent in immigration system with different number of counters.

Discussion of above result, 51 is the best number of counters needed to be opened for serving the passengers as it is the lowest number of counters which makes passengers do not have to wait in the queue. Airport seeks for a strategy to reduce the cost as much as possible. Meanwhile, they are still able to gain the passenger satisfaction. Noticed from the results, 32 counters is the lowest number that save the cost, but the passengers have to wait in the queue for 2.0166 minutes and spend time to get the service for 1 minutes, so total service time spent in the system is 3.0166 minutes. On the other hand, 52, 53, 54 and 55 are not good numbers because the airport wastes the money to hire too many officers while passengers do not have to wait in the queue at 51 counters onward.

In the second angle, different months show the different traffic amount at the airport. However, the pattern of number of arrival passengers each year looks similar as shown in the figure 3. The difference is the number of passengers increase around 11% every year. This paper also aims to reveal the average service time passenger spent in the system or W_s in different periods of time in the entire year. In addition, average server utilization identified by ρ and average number of passengers in the queue or L_q are also revealed in the following figure. 45 is set to be the number of counters in this experiment.

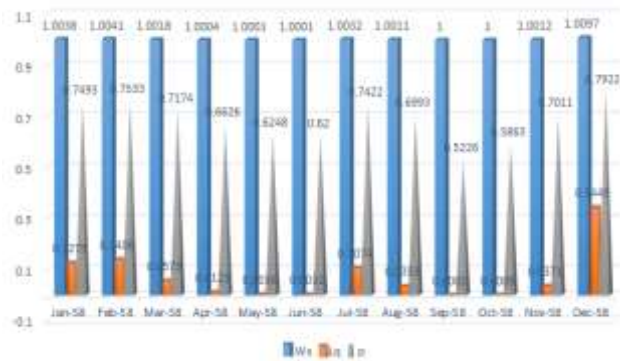

Figure 6. Comparison of average service time, average server utilization and average number of passengers in the queue in different months.

The characteristic for effective queuing system is maximum server utilization, minimum average number of passenger in the queue and minimum average service time. From figure 6, the passengers do not have to wait in the queue in the months of September and October. In contrast, their average service time spent in the system is different for the others depending on the traffic volume. It can be noticed that maximum server utilization occurs in the month of December which means all immigration officers keep working around 79.22% of whole time and idle time is around 20.78%. However, December is the busiest month in the year and this makes passengers have to spent long time in the queue and system.

Discussion of results, multichannel service facility makes the immigration service more efficient. It clearly indicates that as soon as the passengers enters the system, they are being served. Once the serving capacity increases, it will bring more profit, purchase volume in the shopping area and passenger satisfaction to the airport. However, it is necessary for the airport to make a smart decision and plan on the appropriate manpower capacity ahead for each month due to the different of traffic amount. This effective management will lead to the cost optimization.

V CONCLUSION

Due to the rapid increase of air passengers in the last decade, it is necessary for airport to seek the strategy to implement effective queuing system for the

immigration. The survey shows that some airports still use the traditional queuing system which makes the passengers have to spend 15 – 30 minutes at the immigration service. This can lead to the decreasing of purchase capacity and passenger satisfaction as they have to wait at immigration for long time. Consequently, this paper aims to propose the hybrid method, the integration of data analytics and queuing theory, to reveal the performance of queuing system. M/M/C queuing model was applied in the proposed technique for immigration service, Suvarnabhumi international airport. The experiment shows that the proposed technique provides a significant benefit for immigration service. This technique can be used to suggest the appropriate number of counter opened at immigration, in order to gain maximum server utilization, minimum average number of passenger in the queue and minimum average service time spent in the system. By using the proposed technique, airport can plan the manpower capacity and make a smart decision on managing immigration system for getting the cost effective.

REFERENCES

- Adan, I., & Resing, J. (2015). Simple analysis of a fluid queue driven by an M/M/1 queue. *Queueing Systems*, 22(1), 171-174. doi: 10.1007/BF01159399.
- Agner Krarup Erlang. (1878 - 1929) "plus.maths.org". Pass.maths.org.uk. Retrieved 2013-04-22.
- Carbonneau, R., Laframboise, K., Vahidov, R. (2008). Application of machine learning techniques for supply chain demand forecasting. *European Journal of Operational Research*, 184, 1140-1154.
- De Lange, R., Samoilovich, I., & van der Rhee, B. (2013). Virtual queuing at airport security lanes. *European Journal of Operational Research*, 225(1), 153-165.
- Green, L. V., Soares, J., Giglio, J. F., Green, R. A. (2006). Using Queueing Theory to Increase the Effectiveness of Emergency Department Provider Staffing. *Academic Emergency Medicine*, 13: 61-68. doi: 10.1197/j.aem.2005.07.034
- Harrison, Peter; Patel, Naresh M. (1992). Performance Modelling of Communication Networks and Computer Architectures. *Addison-Wesley*. p. 173.
- Parra, J., Kiekintveld, C. (2013). Initial Exploration of Machine Learning to Predict Customer Demand in an Energy Market Simulation. *Trading Agent Design and Analysis: Papers from the AAAI 2013 Workshop*.
- Sundarapandian, V. (2009). "Queueing Theory". Probability, Statistics and Queueing Theory. *PHI Learning*. ISBN 8120338448.
- Yan, L., Wolniewicz R. H., Dodier, R. (2004). Predicting customer behavior in telecommunications. *IEEE Intelligent Systems*, 19(2), 50-58. doi: 10.1109/MIS.2004.1274911

Blended Learning as a Conduit for Inquiry-based Instruction, Active Learning, Formative Assessment and its Impact on Students' Learning Outcomes in Higher Education

Chan Yuen Fook, Suthagar Narasuman, Siti Fairuz Dalim, Gurnam Kaur Sidhu, and Lee Lai Fong

Universiti Teknologi MARA (Puncak Alam), Malaysia {yuenfook; suthagar@salam.uitm.edu.my}

ABSTRACT

There is a definite impact of inquiry-based instruction, active learning and formative assessment on students' learning outcomes because all of these factors have the tendency to drive student's motivation, interest and performance in learning, especially when it is grounded in the use of the Blended Learning (BL) method. In view of this, the study attempted to identify the effect of these factor(s) on students' learning outcomes such as self interest, self efficacy and cognitive development. This study employed a quantitative method and a 5 point Likert scale survey instrument was used to gauge the response from students at the Faculty of Education in a public university. A total of 500 questionnaires were distributed and about 80% were returned from 444 student respondents. BL based formative assessment was found to be a strong contributor to the variance in learning outcomes, in higher education. The study indicated that a student's interest, cognitive development and self efficacy were influenced by many factors however, providing them with BL based active learning opportunities were extremely fruitful. In addition, inquiry based instruction and formative performance assessment are known as outstanding methods in recent years that have produced a shift in the focus of students' attention particularly towards learning in tertiary institutions.

Keywords: Blended Learning, Inquiry-based Instruction, Active Learning, Formative Assessment, Learning Outcomes, Higher Education

I INTRODUCTION

Globalisation and internationalisation has served as a catalyst for the transformation of higher education all around the globe including Malaysia. It was against this backdrop, that the Malaysian Ministry of Higher Education had (MOHE) launched the National Higher Education Strategic Plan (NHESP) which laid the foundation for the transformation of higher education in Malaysia. One of the main initiatives under the Malaysian NHESP is the development of quality human capital through a holistic approach that cuts across all disciplines and focuses on communication and entrepreneurial skills. Under the NHESP, the teaching and learning pillar encourages the use of a dynamic and market relevant curriculum that makes use of BL as a conduit for transforming the existing pedagogy.

This is deemed a necessary part of the transformation as close to 31,000 Malaysian university graduates were unemployed during the last quarter of 2006 (Morshidi et al., 2008) and the numbers have been

adding up over the years. Among the main reasons cited for graduate unemployment were limited English Language proficiency, poor communication skills, inability of graduates to apply their knowledge in the work environment and a mismatch between university curricular and market demands (Morshidi et al., 2008). Thus, the NHESP had proposed that university curricula be reviewed to ensure it stimulates creativity, innovation, leadership and entrepreneurship alongside the utilisation of technology as a conduit. Besides that, there is a call for "peer review and industry collaboration for curricular development and evaluation" so that universities can equip their undergraduates with appropriate skills to compete in the ever-changing market (Ministry of Higher Education, 2007:27). In fact, NHESP has pointed out the importance of improving the teaching and learning aspect in higher education in Malaysia. Furthermore, there has been a call for a shift in the mode of presentation to an affective rather than a cognitive approach. Going hand-in-hand with this paradigm shift in holistic teaching and learning is assessment; an important aspect of pedagogy. The NHESP also provides systematic diffusion of knowledge through methodically selected pedagogic tools. It is also empowered by nationalistic ideals, principles and philosophy. In relation to this the National Educational Blueprint 2013 has outlined the importance of online learning in the national educational curriculum.

II LITERATURE REVIEW

Numerous studies have revealed the positive effect of inquiry-based instruction on teaching and learning (Avery & Meyer, 2012; Marshall & Horton, 2011). For example, a study by Wang, Wu, Yu and Lin (2015) has shown that there was an increased level of learning motivation and interest after implementing inquiry-based instruction in science subject. The study by Wang and Wu (2008) also revealed that inquiry-based instruction had a very significant effect on students' cognitive ability, students' interest, attitude toward science, skills domain, self efficacy, and performance-goal orientation. Meanwhile, Ali (2014) had also revealed a significant difference in mean scores of students who been taught using inquiry-based instruction.

On the other hand, Bransford, Brown & Cocking (1999), found that active learning allows learners control over their own learning and shape their cognitive, motivational and emotional learning processes that support self-regulated learning. A study by Gao and Hargis (2010) also found that active learning could promote and improve students' interest in learning. In their study among computer science students, they found that students who were engaged in the active learning process were able to identify their creativity through various class

activities that later improved their self-awareness and self-confidence. According to Solberg et al. (1993) self-efficacy has increased students' confidence in doing academic tasks such as reading textbooks, asking questions in class and preparing for exam. Furthermore a study by Chan et al. (2015) among 461 students (diploma, undergraduate and postgraduate) at the Faculty of Education in a public university in Malaysia reveals a moderate, positive and very significant relationship between "learning obligation (active learning's dimension)" and self efficacy ($r=.433$, $p<.01$) of the students. They also discovered a moderate, positive and very significant relationship between "collaboration in learning (active learning's dimension)" and self efficacy ($r=.496$, $p<.01$) and a weak, positive and significant relationship between "learning effort (active learning's dimension)" and self efficacy ($r=.343$, $p<.01$) of the students. They then further investigated the constructs using multiple regression to confirm the significant contribution of "learning obligation" and "collaboration in learning" towards the enhancement of self efficacy among students in higher education. Freeman et al. (2014) in their meta-analyses study also found that active learning increases undergraduates' performance ($r=9.781$, $p<.001$) in science, engineering and mathematics compared to traditional lecturing. They reported an improvement by 6% in average examination scores in active learning and showed the impact of active learning on student mastery of higher-versus-lower level of cognitive skills.

Furthermore, Black and William (2009) portray the importance of formative assessment in triggering student learning gains. In fact, formative assessment enables both instructors and students to work consistently in the zone of proximal development (Heritage, 2010). Heritage (2010) uncovered the importance of feedback on motivation and self-efficacy which is in parallel to a study conducted by Dweck (1999). Dweck studied performance-oriented students and she found that incrementally intelligent students regard errors as a new source of learning. The feedback from formative assessment inherently supports the incremental view of learning and the student stance of pro-active self efficacy connected with it. High levels of self-efficacious students are found where feedback on initial success is significant to potential ability (Swann, Pelham & Chidester, 1988) in learning. Besides that, a study conducted by Hwang and Chang (2011) posit that formative assessment has a positive effect on fifth grade students' learning interest and attitude, as well as their achievement. They managed to show significant improvement of the experimental group's result both in learning interest and learning attitude after the students participated in the learning activity. This result indicates that the formative assessment approaches improved students' interest as well as their attitude towards learning the course content (Hwang & Chang, 2011).

Researchers also believe that inquiry-based instruction leads to the execution of active learning because it augments an individual's interest with the study. Felder and Brent (2009) further claimed that active learning can also be obtained through formative assessment because this evaluation leads to active teaching. Furthermore, the

work of Felder and Brent (2003) specified that active learning expands the situational interest of students which later results in improved interest and persistence in academics. The review above provides a strong case for active learning in improving students' attitude and performance. The study of Rotgans (2014) also stated that students' interest is strongly influenced through numerous factors, however providing them with the active learning opportunities is extremely fruitful. In addition, Beach and Myers (2001) explained that inquiry based instruction and formative performance assessment are known as an outstanding feature of studies in recent years that has produced a shift in the focus of students' attention, particularly towards enhancing approaches in learning and education. As noted by the above mentioned researchers, the instructors' pedagogical approaches and techniques affect students' cognitive ability that indirectly affects students' performance.

BL has been characterized as a teaching and learning model that combines both traditional classroom approach with an e-learning approach. BL can likewise be described as the integration of e-learning tools in a virtual learning environment with the conventional learning environment. BL has not only combined different media but also emphasised on the significance of the students learning outcomes when planning, creating and delivering BL. Some of the earliest studies refer to BL as a separate subdivision of the E-learning domain. While contemporary studies refer to BL as a fastidious mix of conventional and online learning experience (Garrison D. R., 2008). Tapsir (2016) notes that by 2025, 70% of the learning mode in higher education would be changed to BL.

III RESEARCH METHODOLOGY

The study was conducted at the Faculty of Education of a public university in Malaysia. A total of 100 diploma, 250 undergraduates and 150 postgraduate students from the Faculty of Education had responded to the questionnaires. Cluster sampling was chosen because it was much cheaper and more convenient to sample the population in a cluster rather than random sampling (Fraenkel et al., 2012).

The study utilised a descriptive-correlation research design to identify the relationship between independent variables of teaching, blended learning and assessment practices with the dependent variable of learning outcomes. Figure 1 shows the relationship between the independent and dependent variables in the study. The independent variables were the factors that the researchers intended to study in order to evaluate the possible effect on the dependent variable (Fraenkel et al., 2012). Therefore, the researchers assumed that the independent variables are contributing variables that have an effect on the dependent variable. The independent variables in this study were inquiry-based instruction, active learning and formative assessment presented through BL, while the dependent variables were situational interest, self-efficacy and cognitive development which form the students' learning outcomes. According to the research framework stated above, the researcher assumes that blended inquiry-based instruction, active learning and formative performance-based assessment would have an effect on

students' learning outcomes, in specific, situational interest, self-efficacy and cognitive development.

Data collection through questionnaires were done at the end of the semester, in specific after their paper and pen exams. During the semester assignments, quizzes and test which form part of their formative assessment package was conducted through the attendant and ubiquitous university Learning Management System (LMS).

Independent Variables Dependent Variables

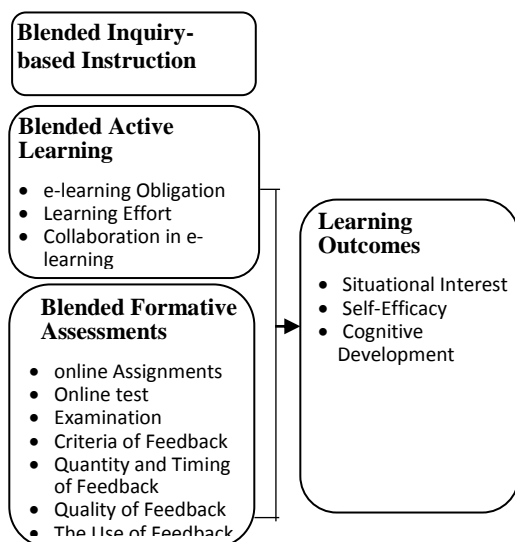

Figure 1. Conceptual Framework of the Study

Projects and assignments also involved the use of web 2.0 applications. Apart from the assessment 50% of the in class activities also involved using the universities LMS, MOOC's and web 2.0 applications. For instance one group of students undertaking a TESL programme at the undergraduate level had to make a recording of their sonnet recitation. This was uploaded to YouTube and the YouTube clip was linked to a mashable application (e.g Blendspace, Prezi, Wallwisher) which combined among other things their interpretation of the sonnet. In-class presentation and discussion was done using the application. Feedback was provided through the LMS as well as in class.

IV FINDINGS

Out of 500 survey questionnaires that were distributed to students at the Faculty of Education UiTM, 444 were returned with complete answers yielding a response rate of 88.8%. A majority (79.1%) of the respondents were females and only 20.9% were males. Based on ethnicity, Malays formed the majority of the respondents (96.2%, n=427). This was followed by other ethnicities, 1.8% (n=8), Iban 1.1% (n=5) and the least were Kadazans 0.9% (n=4). All of the respondents were Malaysian citizens. In terms of age, the students' were ranged from 18 to 49 years old throughout the undergraduate and postgraduate programs. The highest percentage of age distribution of students at the Faculty were 21-25 years old, yielding 57.4% as the majority (n=255). The second highest average age of respondents was 20 and below (26%, n=115). Age ranged from 36-40 and; 41 and above were

the least age of respondents, yielding only 1.1% respectively.

Further analysis was conducted to identify any significant predictors of independent variables (blended inquiry-based teaching instruction, active learning, formative assessment, gender and programs) to students' learning outcomes in terms of situational interest, self-efficacy and cognitive development. Five independent variables namely inquiry-based teaching instruction, active learning, formative assessment, gender and programs; were entered into a multiple regression model to identify their contribution to the dependent variable of students' learning outcomes in higher education. The multiple regression model for this study was proposed as follow:

$$Y = a + \beta_1X_1 + \beta_2X_2 + \beta_3X_3 + \beta_4X_4 + \beta_5X_5 + e$$

(equation 1)

Where,

Y = Students' learning outcome (situational interest, self-efficacy, cognitive development) (dependent variable)

a = regression constant

β_1 = standardised beta coefficient for inquiry-based instruction

X_1 = inquiry-based instruction

β_2 = standardised beta coefficient for active learning

X_2 = active learning

β_3 = standardised beta coefficient for formative assessment

X_3 = formative assessment

β_4 = standardised beta coefficient for gender

X_4 = gender

β_5 = standardised beta coefficient for program of study

X_5 = program of study

e = random error

Table 1. Multiple regressions to determine predictors for students' learning outcomes (students' situational interest, self efficacy and cognition development) in higher education

Model Summary				
Model	R	Adjusted R Square	Std. Error of the Estimate	
1	0.504	.254	.249	.23382

a. Predictors: (Constant), FA, IBI, AL
 b. Dependent Variable: Students' Learning Outcome (Situational Interest, Self Efficacy, Cognitive Development)

Table 2. ANOVA analysis of the variables

Model	Sum of Squares	df	Mean Square	F	Sig.
1 Regression	8.186	3	2.729	49.914	.000
Residual	24.055	440	.055		
Total	32.241	443			

a. Dependent Variable: Learning Outcome (Situational Interest, Self Efficacy, Cognitive Development)
 d. Predictors: (Constant), FA, IBI, AL

Table 3. Coefficients of the variables

Variables	Unstandardized Coefficients		Std Coefs		
	B	Std. Error	Beta	t	Sig.
(Constant)	1.359	.135		10.034	.000
FA	.271	.042	.309	6.455	.000
IBI	.155	.041	.166	3.785	.000
AL	.117	.032	.174	3.628	.000
Gender	.010			.230	.818
Program of Stud	.002			.053	.958

The ANOVA result ($F=49.914$, $p<.01$) further confirmed the significant contribution of “Blended Inquiry-based Instruction”, “Blended Active Learning”, and “Blended Formative Assessment” towards the “Students’ Learning Outcomes” in higher education. Table 3 shows that blended inquiry-based instruction, X_1 ($t=3.785$, $p=.000$), blended active learning, X_2 ($t=3.628$, $p=.000$) and blended formative assessment, X_3 ($t=7.720$, $p=.000$) have significantly contributed to the variance of students’ learning outcomes which consist of three dimensions namely situational interest, self-efficacy and cognitive development. However, the other two independent predictors were found to have no significant contribution to the variance of students’ learning outcomes in higher education. These two factors were gender, X_4 ($t=.230$, $p>.01$) and program of study, X_5 ($t=.053$, $p>.01$). Therefore, only the independent predictors of blended inquiry-based instruction, blended active learning and blended formative performance-based assessment were reliably predicting the dependent variable of students’ learning outcomes.

Based on the magnitude of the standardised beta coefficient, the reported values depict that formative assessment has contributed most strongly to the variance of students’ learning outcomes in higher education with the highest standardised beta coefficient value ($\beta=.309$), followed by active learning ($\beta=.174$), inquiry-based instruction ($\beta=.166$), gender ($\beta=.010$) and lastly, programs of study ($\beta=.002$). Thus the final estimated multiple regression equation was presented as below:

$$Y = 1.359 + .309X_1 + .174X_2 + .166X_3 + e$$

(equation 2)

Table 1 also presented the value of R^2 and adjusted R^2 . The R^2 was .254 and adjusted R^2 was .249. These figures indicated that only 25.4% (based on R^2) or 24.9% (based on adjusted R^2) of the total variances of the learning outcomes of students’ situational interest, students’ self-efficacy and students’ cognition development in higher education were predicted by the practices of inquiry-based teaching instruction, active learning and formative assessment in higher education. Comparatively, the adjusted R^2 value provided a better estimation of the true population value. As a conclusion, the final estimated multiple regression model indicated that the three predictors of blended inquiry-based instruction, blended active learning and blended formative assessment have accounted for 24.9% of the explained adjusted variance in students’ learning outcomes (situational interest, self-efficacy and cognitive development) in higher education.

V DISCUSSION

The findings from this study indicate that inquiry-based instruction, active learning and formative assessment carried out using a BL method were effective measures to enhance students’ learning outcomes in higher education. In fact, the teaching and learning processes experienced by students are not only to improve their critical thinking, but also to enhance their ability to analyse and evaluate in the classroom (Chan et al., 2015). Inquiry-based instruction is part of active learning in which the students will engage in a quest, formulate and construct new understandings, meaning and knowledge; and share with others (Alvarado & Her, 2003). Hence, the findings of this study indicated that both the blended inquiry-based instruction and blended active learning were significant predictors for students’ learning outcomes. Thus, inquiry-based instruction is designed for student-centred learning, and teachers play the role of learning drivers (White-Clark et al., 2008). Coupled with BL teachers become facilitators while students take charge of their learning.

Zulhamri et al. (2014) further posit that student-centred learning can be a medium to nurture students towards increasing their self efficacy as has been proven in this study. The findings of this study is also paralleled with a study by Gaffney et al. (2012) who states, elements related to active learning such as working in teams, doing activities and hands-on applications positively influence students’ self-efficacy. Furthermore, Jungert & Rosander (2010) state that students’ involvement in problem-based learning methods lead to higher self-efficacy because they have the opportunity to apply their knowledge on authentic and conceptualised problems, along with active communication with their peers. This approach uses both social and cognitive interactions. Besides that, the findings of this study also supported the findings by Greeno, Collins & Resnick (1996) who found that active learning elevates students’ curiosity and motivation to explore their interests associated with the materials which espouse independent learning. Notably, inquiry-based instruction and active learning increases affective and cognitive outcomes (Herman & Knobloch, 2004) as have been reported in this study. As a result, students are motivated by blended inquiry learning because it permits active engagement in the learning process, especially in the process of finding the answers that motivate them to search for it. As a conclusion, blended inquiry-based instruction as a subset to blended active learning approach has a great impact on student engagement.

The multiple regression analysis in this study indicated that blended formative assessment as the major predictor to students’ learning outcomes. This finding supports Tomlison (2008)’s argument that classroom assessment is helpful in monitoring student’s learning progress and instructor(s) instruction improvement. Chan et al. (2011) in an earlier study had found that providing feedback to students, would help them to analyse and cope with their weaknesses and tackle the learning problem appropriately. This is in-line with a study by Light, Cox and Calkins (2009) where feedback was found to have significant importance, for example, helping students understand their mistakes and underlying causes of those mistakes, provide ways to improve learning, identifying

areas of achievement and providing students with professional and personal growth.

VI CONCLUSION

The significant relationship between inquiry-based instruction, active learning and formative assessment through a BL method and learning outcomes, warrants the development of a comprehensive system to moderate the cycle of teaching and learning in higher education. The findings of this study indicated that all the three aspects of inquiry-based instruction, active learning and formative assessment correlated positively and significantly with each other. These three aspects were also correlated positively and significantly with the learning outcomes of situational interest, self-efficacy and cognitive development. This implies that adding e-learning elements that contribute to active learning and formative assessment, enables students to experience improved levels of transformative learning.

ACKNOWLEDGMENTS

This paper is part of a research project funded by Fundamental Research Grant Scheme (FRGS), Ministry of Education, Malaysia, and Research Management Institute, Universiti Teknologi MARA.

REFERENCES

- Ali, A. (2014). The effect of inquiry-based learning method on students academic achievement in science course. *Universal Journal of Educational Research*, 2(1), 37-41.
- Alvarado, A.E. & Her, P.R. (2003). *Inquiry-based learning using everyday objects: hands-on instructional strategies that promote active learning in grades 3-8*. Corwin Press.
- Avery, L. M. & Meyer, D. Z. (2012). Teaching Science as Science Is Practiced Opportunities and Limits for Enhancing Preservice Elementary Teachers Self-Efficacy for Science and Science Teaching. *School Science and Mathematics*, 112(7), 395-409.
- Beach, R. & Myers, J. (2001). *Inquiry-based English instruction: Engaging students in life and literature*. New York: Teachers College Press.
- Black, P. & William, D. (2009). Developing the theory of formative assessment. *Journal of Personnel Evaluation in Education*, 21(1), 5-31.
- Bransford, J., Brown, A. L., Cocking, R. R., & National Research Council (U.S.). (1999). *How people learn: Brain, mind, experience, and school*. Washington, D.C: National Academy Press.
- Chan, Y. F., Siti Fairuz, D., Suthagar, N., Gurnam, K.S., Lee, L.F. & Khor, M.K. (2015). Relationship between active learning and self efficacy among students in higher education. *International Academic Research Journal*, 1(2), 139-149.
- Dweck, C. S. (1999) *Self-theories: Their role in motivation, personality and development*. Philadelphia: Psychology Press.
- Felder, R.M. & Brent, R. (2009). Active Learning: An Introduction. *ASQ Higher Education Brief*, 2(4), 56-100.
- Gaffney, J.D.H., Gaffney, A.L.H., Usher, E.L. & Mamaril, N.A. (2012). How an active learning class influences physics self efficacy in pre-service teachers. *Physics Education Research Conference AIP Conf. Proc.*, 1513, 134-137.
- Garrison, D. R. (2008). *Blended Learning in Higher Education: Framework, Principles, and Guidelines*. San Francisco: Wiley.
- Gao, J. & Hargis, J. (2010). Promoting technology-assisted active learning in computer science education. *The Journal of Effective Teaching*, 10(2), 81-93.
- Greeno, J.G., Collins, A.M. & Resnick, L.B. (1996). Cognition and learning. In d. Berliner & R. Calfee (Eds.). *Handbook of Educational Psychology* (pp. 15-41). New York: MacMillian.
- Heritage, M. (2010). Formative assessment and next generation assessment systems: are we losing an opportunity? *The Council of Chief State School Officers*, 1-20.
- Herman, J. M., & Knobloch, N. A. (2004). *Exploring the effects of constructivist teaching on students' attitudes and performance*. Proceedings from the 2nd Annual North Central Region AAAE Research Meeting. Lafayette, IN: 21-35.
- Hwang, G. J. & Chang, H. F. (2011). A formative assessment-based mobile learning approach to improving the learning attitudes and achievements of students. *Computers and Education*, 56 (4), 1023-1031.
- Jungert, T. & Rosander, M. (2010). Self-efficacy and strategies to influence the study environment. *Teaching in Higher Education*, 15(6), 647-659.
- Light, G., Cox, R. & Calkins, S. (2009). *Learning and teaching in higher education: The reflective professional (2nd ed.)*. London: Sage.
- Marshall, J.C. & Horton, R.M. (2011). The relationship of teacher-facilitated, inquiry-based instruction to student higher-order thinking. *School Science and Mathematics*, 111(3), 93-101.
- MOHE. (2007a). *Pelan strategik pengajian tinggi negara melangkaui tahun 2020*. Putrajaya.
- MOHE. (2007b). National higher education action plan 2007-2010. In MOHE (ed.). Putrajaya.
- Morshidi, S., Pandian, A., Muniandy, B., Fazal, M.M.S., Harshita Aini, H., Hazita, A., Kabilan, M.K. & Ratna Roshida, A.R. (2008). The university curriculum and the employment of graduates. In Md. Yusof, A.B., Nor Aieni, H.M., Rohana, J., Ainol, M.Z., Norasmah, O. & Aries, G. (ed). *Enhancing the quality of higher education through research: Shaping future policy. Ministry of Higher Education*, 136-159.
- Rotgans, J.I. (2014). Situational interest and learning: Thirst for knowledge. *Learning and Instruction*, 32(2), 37-50.
- Solberg, V.S., O'Brien, K., Villareal, P., Kennel, R. & Davis, B. (1993). Self-efficacy and Hispanic college students: Validation of the college self-efficacy instrument. *Hispanic Journal of Behavioral Sciences*, 15, 80-95.
- Swann, W.B., Pelham, B.W. & Chidester, T. (1988). Change through paradox: using self-verification to alter beliefs. *Journal of Personality and Social Psychology*, 54, 268-273.
- Tapsir, Siti Hamisah. 2016. A Strategy For The Next Decade Of Malaysian Higher Education. ACU Perspectives Speaker Series No. 8, 19 January 2016. Accessed 26 June, 2016 from <https://www.acu.ac.uk/events/perspectives/datin-siti-hamisah-presentation>
- Tomlison, C.A. (2008). The goals of differentiation. *Educational Leadership*, 26-30.
- Wang, P.H., Wu, P.L., Yu, K.W. & Lin, Y.X. (2015). Influence of implementing inquiry-based instruction on science learning motivation and interest: A perspective of comparison. *Procedia-Social and Behavioral Sciences*, 174, 1292-1299.
- Wang, S. L., & Wu, P. Y. (2008). The role of feedback and self-efficacy on web-based learning: The social cognitive perspective. *Computers & Education*, 51(4), 1589-1598.
- White-Clark, R., DiCarlo, M. & Gilchrist, N. (2008). Guide on the side: an instructional approach to meet mathematics standards. *The High School Journal*, 40-44.
- Zulhamri Abdullah, Mohd Fauzi Ramlan, Mohammad Shatar Sabran & Syed Agil Alsagoff (2014). Towards a university branding: The effect of self-efficacy on student development in a major higher education institution. *Jurnal Personalia Pelajar*, 17, 49-61.

Determination Of Corporate Governance Disclosure Case Study On Islamic Banking In Indonesia

Chrisna Suhendi, and Maya Indriastuti

Sultan Agung Islamic University (UNISSULA), Indonesia, {chrisnasuhendi; maya}@unissula.ac.id

ABSTRACT

Corporate governance concept focuses on two things, firstly, the right of shareholders to obtain information on time and correctly, secondly, the company's obligation to reveal all information the company's performance accurately, timely and transparently to stakeholders. Disclosure of corporate governance is influenced by several factors; these are the dispersion of ownership, board size, company size, and profitability. This study aimed to look at the factors that influence the corporate governance disclosure. This study population using all banking companies listed in Islamic Banks (BUS) during 2011-2014 that as many as 44 Islamic Banks. The sample was taken by purposive sampling method. The results of this study indicate that simultaneously all independent variables have a significant positive effect on corporate governance disclosure. Partially ownership dispersion and board size has positive influence on corporate governance disclosure.

Keywords: corporate governance disclosure, the dispersion of ownership, board size, company size, and profitability.

I INTRODUCTION

Corporate governance practices in the modern enterprise has increased in the last decade, especially since the collapse of major US corporations such as Enron Corporation and Worldcom. In Indonesia, the government's attention to this problem is realized with the establishment of Komite Nasional Kebijakan Governance (The National Committee on Governance Policy =NCGP) at the end of 2004.

Corporate Governance is a process and structure that applied to running the company with the main goal of improving shareholder value in the long term by taking into account the interests of other stakeholders (shareholders, creditors, suppliers, customers, employees of corporations, governments and communities that interact with

the company). Corporate governance concept focuses on two things, firstly, the right of shareholders to obtain information on time and correctly, secondly, the company's obligation to reveal all information the company's performance

accurately, timely and transparently to stakeholders. (Zef, 2012).

Corporate governance is important to maximize the company's value added in order to win the global competition, to prevent a fraud and corruption, to encourage the creation of a market that is efficient, transparent and consistent with legislation that is based on some basic principles of good corporate governance (Transparency, Accountability, Responsibility, Fairness). In addition, corporate governance can minimize the cost of capital, improve the corporate image, and increase the value of company stock (Zef, 2012).

Iskander and Chamlou (2000) in Wisdom et al., (2011) stated that the economic crisis in Southeast Asia and others countries is not only caused by macroeconomic factors, but also caused by the weak of corporate governance, such as legal weak, weak of commissioner supervision, and the neglect of minority rights.

Some of research result of corporate governance disclosure in Indonesia companies are affected by (1) Ownership Dispersion {(Sayono, 2006); Rini (2012) and Pramono, 2011)}; (2) Company Size {(Sayono, 2006); Pramono, 2011); Wisdom et. al., 2011); and Natalia and Zulaikha, 2012)}; (3) the number of commissioners {(Sayono, 2006); Rini (2010); and Wisdom et. al., 2011)}; (4) profitability (Natalia and Zulaikha, 2012).

Jifri and Hussainey (2007) states that corporate governance disclosure in America corporate is only influenced by the profitability. Disclosure of corporate governance in a Canadian company is influenced by firm size and profitability (Maingot and Daniel, 2008) as similarly as in Bangladesh (Bhuiyan and Biswas, 2007), while in Malaysia is only influenced by the size of the company (Mohammed et al., 2009).

A. The Effect of Owners Dispersion to Corporate Governance Disclosure

Companies with a high level of ownership dispersion will reveal any information in high level too (Jensen and Meckling, 1976). This is fit the needs of each investor and as a responsibility to investors.

Sayono (2006); Rini (2010); and Pramod (2011) state ownership dispersion has a positive influence on corporate governance disclosure.

H₁: Owners Dispersion has a positive effect on corporate governance disclosure.

B. The Effect of Commissioners Board Size to Corporate Governance Disclosure

The commissioners need to monitor and control managers behavior actions (Jensen and Meckling,1976). The greater number of commissioners will be easier to control and supervise the manager performance effectively. Therefore, disclosure undertaken by management will also increase [Sayono, (2006); Rini (2010); and Wisdom et al., (2011)].

H₂: The size of the board of commissioners has positive influence on corporate governance disclosure.

C. The Effect of Company Size to Corporate Governance Disclosure

Companies with a larger size tend to have a more complex relationship with the stakeholders, so that the company will provide relevant information to stakeholders [Natalia and Zulaikha (2012) and Wisdom et al., (2011), Mohammed et al., (2009) and Sayono (2006)]. Increased levels of corporate governance disclosure will reduce agency costs and information asymmetries (Natalia and Zulaikha, 2012).

H₃: Company Size has positive effect on corporate governance disclosure.

D. The Effect of Profitability to Corporate Governance Disclosure

Profitability is the ability of a company to make a profit on sales, assets and stock capital (Retrinasari,2007). Increasing in the number of profit must be accompanied by Information disclosure, especially, information regarding to corporate governance. This information can be viewed as a company's responsibility for the use of funds.

Natalia and Zulaikha (2012); Jifri and Hussainey (2007) states that profitability has a positive effect corporate governance disclosure.

H₄: Profitability has positive effect on corporate governance disclosure.

II RESEARCH METHODS

A. Population and Sampling

The population used in this study are all Islamic Banks, operating in 2011-2014. Sample were selected by purposive sampling, with the following criteria: (1) publish an annual report and corporate governance report for the period 2011-2014; (2) the content of that report includes things that must be disclosed by Islamic Banks (BUS) accordance with Article 62 of Bank Indonesia Regulation No. 11/33 / PBI / 2009; and (3) an annual report published by the BUS must possess completeness of the data used in this study.

B. Operational Definition and Measurement of Variables

Table 1 shows a list of variables with their operational definition.

Table 1. Operational Definition and Measurement of Variables

No	Variable Name	Operational Definition	Measurement of Variables
1	Corporate governance disclosure (Y)	The Way to ensure that management acts is the best for stakeholders.	Measured by a composite score based on quality ratings GCG bank conformity. The implementation of SEBI regulation No. 12/13 / DPbS Year 2010.
2	Ownership Dispersion (X ₁)	Dispersed shareholding owned by individual investors.	Percentage shares held by shareholders whose ownership ≤5%.
2	The size of the Board of Commissioners (X ₂)	The number of commissioners owned by the company, consisting of the Chief Commissioner, the independent commissioner, and the commissioner.	The number of commissioners that is owned by the company.
3	Company Size (X ₃)	Large or small a company.	Total assets of the company.
4	Profitability (X ₄)	The ability of a company to generate a profit on the level of sales, assets and stock capital.	Measured by Return on Assets (ROA). $ROA = \frac{\text{Net Profit After Tax}}{\text{Average Assets}}$

Sources : Hilmah et al., 2011

C. Data Analysis

The analytical method used is multiple linear regression, using SPSS 20 with the model equations as follows :

$$CGD = a + b_1 OD + b_2 BoC + b_3 CZ + b_4 P + e$$

Note:

CGD = Corporate Governance Disclosure (Y)

OD = Ownership Dispersion (X₁)

BoC = Board of Commissioners (X₂)

CZ = Company Size (X₃)

P = Profitability (X₄)

e = Standard Error

III RESULTS

The result can be seen as presented in Table 2 belows :

Table 2. Result of The Partial Test

No	Variables	T	Sig.
1	Ownership Dispersion	0,218	0,017
2	Size BOC	2,816	0,012
3	Company Size	-1,150	0,251
4	Profitability	-2,118	0,156
F count			2.465
F Sig			0,012
Adjusted R Square			0,523

It can be seen that, all independent variables together have a significant positive effect with significant F value of 0.012 and the dependent variable can be explained 52,3% by the independent variable. The results of the partial test showed that the variables of ownership dispersion(OD) and board size(BoC) have a significant positive effect (sig. Below 5%) to the corporate governance disclosure, while firm size and profitability variable have a negative impact not significant (sig. above 5%).

IV DISCUSSION

A. Effect of Dispersion Owners to Corporate Governance Disclosure.

Owners dispersions have a positive effect to the corporate governance disclosure, the results accordance to the agency theory. Jensen and Meckling(1976) states that companies with a high level of ownership dispersion will disclose high. Ownership dispersion owned by an individual have an ability to pressure on the management regarding corporate governance. This disclosure in accordance with the needs of each investor. Disclosure can be viewed as a form of responsibility to investors. The results of this study are consistent with research done by Sayono (2006) and Pramod (2011) which states that ownership dispersion positive influence on corporate governance disclosure. but not in line with the research Hikmah et.al. (2011).

B. Effect of BoC to Corporate Governance Disclosure.

Board size has positive influence to corporate governance disclosure. Board of Commissioners have responsible to control and provide consultation to management, especially on management strategic options in decision making. The greater the commissioners become more effective. It is possible for management to prepare and fight for very

complex obstacle. The results of this study are consistent with the Wisdom et. al. (2011) which states that the board size has positive influence on corporate governance disclosure. However, this result is not inline with Sayono (2006).

C. Company Size Effect to Corporate Governance Disclosure

Size negatively affect the company's corporate governance disclosure. The size of the company described the large or small companies. Companies with a larger size tend to have a more complex relationship with stakeholders. More complex relationships can be seen from the increasing number, types, and demands of stakeholders. Increased complexity Companies tend to eliminate the focus on corporate governance disclosure because of the many demands of stakeholders, so that eventually the company will try to provide information without regard to its focus (Pramono, 2011). These results are in contrast to studies Sayono (2006); Mohammed et.al. (2009); Pramono (2011); Wisdom et. al., (2011); and Natalia and Zulaikha, (2012).

D. Profitability Effect to Corporate Governance Disclosure

Profitability has a negative effect on the disclosure of corporate governance. This happens because when profitability increased, investors often ignore the information as a whole so that the management is not motivated to do the disclosure of corporate governance, whereas when the company experienced a decline in profitability, the company will tend otherwise to face market pressure and convince the markets will be the company's performance in the period next (Jifri and Hussainey 2007; Natalia and Zulaikha, 2012). This result is not the same as research Hikmah et.al. (2011), Pramod (2011) and Sayono (2006).

V CONCLUSION

Based on the research that has been done, it can be concluded: the dispersion of ownership and board size have positive influence on corporate governance disclosure. The owners will ask for more disclosure to oversee the management of opportunistic behavior in comparison with companies that have concentrated ownership. Controlling of management behavior can be done by added the number of commissioners in the company. On the other hand, firm size and profitability have negative affect to corporate governance disclosure. The firms with

larger size tend to have a more complex relationship with stakeholders, and it will tend to eliminate the focus on corporate governance disclosure. Besides that, the increase in profitability will cause investors often ignore the information as a whole, so the management is not motivated to reveal corporate

governance disclosure. In opposite, when the company has a decline in profitability, the company will tend fight to market pressure and convince the markets will be the company's performance in future periods.

REFERENCES

- Aljifri, Khaled and Hussainey Khaled. 2007. "The Determinants of Forward-looking Information in Annual Reports of the UAE Companies", *Journal of Emerald Insight*
- Bapepam. 2006. KEP-134 / BL / 2006 Obligation to Submit Annual Report for Issuers or Public Companies. www.bapepam.go.id
- Bhuiyan, Md Hamid Ullah and P.K. Biswas. 2007. "Corporate Governance and Reporting: An Empirical Study of the Listed Companies in Bangladesh ", *Journal of Business Studies*
- Ghozali, Imam. 2013. "Applications Multivariate Analysis with SPSS Program". Semarang: Diponegoro University Publishers Agency
- Hikmah Noor, Chairina, and Desilarina Rahmayanti. 2011. "Factors Affecting Broad Corporate Governance Disclosure The Banking Companies Listed in Indonesia Stock Exchange", *Accounting National Symposium XIV*
- Maingot, Michael and Daniel Zeghal. 2008. "An Analysis of Corporate Governance Information By Canadian Banks", *Corporate Ownership & Control* Vol. 5 Issue 2 Winter 2008
- Mohammed, Rusnah, Suhaily Shahimi, Yazkhiruni Yahya, Nurmazilah Mahzan. 2009. "Disclosure Quality on Governance Issues in Annual Reports of Malaysian PLCs", *Journal of International Business Research*
- Natalia Petri and Zulaikha. 2012. "Analysis of Factors Affecting Corporate Governance Disclosure in Annual Report", *Journal of Accounting Diponegoro* Vol. 1 No. 1
- Pramono, Adriawan Ferry. 2011. "Effect Analysis Company Characteristics on the Quality of Corporate Governance Disclosure in Annual Report", *Journal of Economics and Business, University of Diponegoro*
- Rini, Kartika Amilia. 2010. "Size Analysis Disclosure of Corporate Governance in the Annual Report of Public Companies in Indonesia", *Journal of Economics and Business, University of Diponegoro*
- Sayono, Djoko Sigit. 2006. "The Determinants of Corporate Governance Disclosure Through Internet for Companies Listing in Jakarta Stock Exchange", *Accounting Symposium IX*
- Zef Zabadi Fairu. 2012. Importance of Good Corporate Governance In A Company. <http://fairuzabadizef.com/2012/12/23/pentingnya-good-corporate-governance-dalam-sebuah-perusahaan/>. Accessed April 7, 2016.

Financial Ratios: Prediction of Changes in Profit Future on Islamic Banks

Maya Indriastuti, and Luluk Muhimatul Ifada

Sultan Agung Islamic University (UNISSULA), Indonesia, { maya; luluk.ifada}@unissula.ac.id

ABSTRACT

This study aims to determine whether the current ratio, profit margin, total asset turnover is able to predict changes in future earnings at 33 Islamic Banks 2011-2013. The research data was tested using multiple linear regression analysis using SPSS version 21. The result is the data shows that the variable margin and total asset turnover significant positive effect on predicted changes in future earnings and current ratio variable positive effect was not significant in predicting changes in profit in the future. These results are very useful for Islamic Banks itself to constantly improve its financial performance with demonstrated their future earnings changes continuously. Positive income changes from year to year will be able to attract investors to invest in the stock Islamic Banks.

Keywords: Current ratio, profit margin, total asset turnover, profit change prediction, Islamic Banks.

I INTRODUCTION

The success of a company can be seen from the performance from year to year, in which the financial information was useful for planning and decision-making short-term and long-term needs to know the company's profit in the present and the future. Statement of Financial Accounting Concept (SFAC) states that the earnings information has a benefit in assessing management performance, helping to estimate the earnings capacity of a representative in the long term, it forecast earnings and assess risks in the investment. Profit forecast is also affected by the financial ratios include current ratio, profit margin and total asset turnover. The current ratio is a ratio to measure a company's ability to pay short-term obligations or debt immediately due when billed as a whole. That is, the amount of liquid assets available to cover short-term liabilities that is due soon. Syamsudin and Primayuta (2009), Asmar (2014), Napatilova (2014), said variable current ratio of positive and significant in predicting earnings changes in the future, otherwise Parawiyati and Baridwan (1998), Taruh (2012), Rosahayu, et al (2014) said the current ratio positive effect was not significant in predicting future earnings changes.

The profit margin (net profit margin) which is one of the profitability ratios. This ratio illustrates the magnitude of the net profit earned by the company on each sale (Darsono and Ashari, 2005: 56). Parawiyati and

Baridwan (1998), Taruh (2012), Adisetiawan (2012) and Napatilova (2014) state variable profit margin significant positive effect in predicting future earnings changes. Different Syamsudin and Primayuta (2009), Asmar (2014) which states that the profit margin positive effect was not significant in predicting future earnings changes. Total asset turnover ratio is used to measure all assets owned by the company turnover and measured how the amount of expenditures obtained from each rupiah assets (Kashmir, 2012: 185). Total asset turnover ratio of activity is used to measure the extent a company's effectiveness in using its resources in the form of assets. Napatilova (2014), Syamsudin and Primayuta (2009) total asset turnover variable states significant positive effect in predicting future earnings changes. Different, Parawiyati and Baridwan (1998), Adisetiawan (2012), Taruh (2012), Asmar (2014) which states total asset turnover positive effect was not significant in predicting future earnings changes.

II DEVELOPMENT HYPOTHESIS

A. Effect of the Current Ratio to Predicts Profit Changes in Future

The current ratio is a ratio to measure a company's ability to pay short-term obligations or debt immediately due when billed as a whole (Kashmir, 2012). That is, how many assets are available to cover short-term liabilities that is due soon. Asmar (2014), Napatilova (2014), Syamsudin and Primayuta (2009) states that the current ratio is able to predict changes in future earnings.

H1: The current ratio positive effect on predict profit changes in future

B. Effect of Profit Margin to Predicts Profit Changes in Future

Profit margins in this study using NPM (Net Profit Margin). NPM ratio illustrates the magnitude of the net profit earned by the company on each sale (Darsono and Ashari, 2005: 56). The greater the net profit margin then the performance of the company will be more productive, so it will increase the confidence of investors to invest in the company. This ratio indicates how much percentage of the net profit earned from each sale. Adisetiawan (2012) and Napatilova (2014) states that the positive effect on profit margin, so this variable was able to predict changes in future earnings.

H2: The profit margin positive effect on predict profit changes in future

C. Effect of Total Assets Turnover to Predicts Profit Changes in Future

Total asset turnover ratio is used to measure all assets owned by the company turnover and measured how the amount of expenditures obtained from each rupiah assets (Kashmir, 2012). Total asset turnover itself is the ratio of sales to total assets measure the efficiency of use of the asset as a whole. If the ratio is low it is an indication that the company is not operating at sufficient volume to capacity investment. Napatilova (2014), Syamsudin and Primayuta (2009) state variable total asset turnover positive effect in predicting future earnings changes.

H3: Turnover of total assets positive effect on predict profit changes in future

III RESEARCH METHOD

This study used a sample of Islamic Banks (BUS) 2011-2013 that as many as 11 Islamic Banks annually. The variables in this study will be tested using multiple linear regression analysis (Ghozali, 2013), the regression equation as follows:

$$CP = a + b_1CR + b_2PM + b_3TTA$$

Description:

CP = Change Profit

A = Constant

B = Coefficient of regression equation

CR = Current Ratio

PM = Profit Margin

TTA = Turnover Total Assets

IV DISCUSSION

Effect of the Current Ratio to Predicts Profit Changes in Future

The current ratio is not significant positive effect on future profit forecasts, with significant value $0.617 > 0.05$. meaning that the size of the current ratio can not affect the size of future profit forecasts. This ratio indicates how many assets are available to cover short-term liabilities that is due soon, so that the company can mngukur level of security (margin of safety). Low current ratio is usually considered to indicate the occurrence of problems in liquidity, but conversely if too large current ratio shows that the management of current assets less good because it shows the amount of idle funds, which in turn can reduce the ability of corporate profits. The results of this study support Rosahayu, et al (2014) which states that the current ratio positive effect was not significant to forecast future earnings, contrast a study Asmar (2014), Napatilova (2014), Syamsudin and Primayuta (2009) which states that the current ratio effect positively significant to forecast future earnings.

Effect of Profit Margin to Predicts Profit Changes in Future

Profit margins are significant positive effect on future profit forecasts, this result proved by the significant value $0.029 < 0.05$. That is, management can see the focus of the magnitude of net income that can be generated from sales can be generated by shareholders. Profitability showed as the profitability of own capital or often referred to as business profitability. The higher this ratio, the better because it gives a greater rate of return on shareholders. The higher the income, the profit or corporate profits increased, so that the profit growth also increased (Wibowo, 2011). These results are consistent with research Adisetiawan (2012) and Napatilova (2014) which states that the results of the profit margin significant positive effect on earnings forecast future, otherwise differ with Asmar (2014), Syamsudin and Primayuta (2009) which states margin positive effect was not significant to forecast future earnings.

Effect of Total Assets Turnover to Predicts Profit Changes in Future

Turnover of total assets has positive influence on the future profit forecasts, this result proved by the significant value $0.025 < 0.05$, meaning that the size of the asset turnover can affect the size of future profit forecasts. This ratio to measure the ability of funds that are embedded in the sale of spins in a certain period or liquidity of sales and selling their tendency to generate cash. The ratio of good report or productive activity for the company, if the ratio activity ratio greater than 1, if slow-moving show that sales held is too small compared with the ability to assets. That is, the higher the turnover rate of assets, the company's ability to sell the product gets higher, so the impact on profit and profit growth. The results of this study support Napatilova (2014), Syamsudin and Primayuta (2014), showed that the asset turnover significant positive effect on earnings forecast future, otherwise do not support research Asmar (2014) and Setiawan (2012) which stated asset turnover positive effect not significantly to forecast future earnings.

V CONCLUSION

Based on the research that has been done, it can be concluded variables capable of predicting profits in the future in the banking company is a variable margin and total asset turnover, while the variable current ratio of not being able to predict future earnings. The results of this study support the research Napatilova (2014) which states that the profit margin and total asset turnover significant positive effect on future earnings forecast. While this study does not support the results Asmar (2014) which states that the profit margin and total asset turnover is not significant positive effect on future earnings forecast. Limitations of this study are the small or low ability of independent variables in explaining the dependent variable by 0.19. That is, the independent variable (the current ratio, profit margin and total asset turnover) can explain the dependent variable (change prediction profit) by 19% while the rest is explained by other variables.

REFERENCES

- Asmar. (2014). "Pengaruh Rasio Keuangan Terhadap Prediksi Perubahan Laba Pada Perusahaan Manufaktur yang Terdaftar di Bursa Efek Indonesia Periode 2008-2012", Badan Penerbit UMRAH, Tanjungpinang.
- Ghozali, Imam. 2013. "Analisis Multivariate dengan menggunakan program SPSS". BPFE Universitas Diponegoro. Semarang
- Parawiyati dan Baridwan, Zaki. 1998. "Kemampuan Laba dan Arus Kas dalam Memprediksi Labadan Arus Kas Perusahaan Go Publik di Indonesia". *Jurnal Riset Akuntansi Indonesia*. Vol.1 No. 2.
- Kasmir. (2012). "*Analisis Laporan Keuangan*". Jakarta: PT. RajaGrafindo Persada.
- Narpatilova, O, 2014. "Pengaruh Rasio Keuangan Terhadap Pertumbuhan Laba Pada Perusahaan Manufaktur Yang Terdaftar Di Bursa Efek Indonesia Periode 2008 – 2012, Badan Penerbit UMRAH, Tanjungpinang.
- Syamsudin dan C. Primayuta, 2009. "Rasio Keuangan dan Prediski Perubahan Laba Perusahaan Manufaktur Yang Terdaftar di Bursa Efek Indonesia". *Jurnal Manajemen dan Bisnis*, Vol. 13 No. 1: 61-69.
- Rosahayu, E., dkk. 2014. "Analisis Rasio Keuangan Dalam Memprediksi Pertumbuhan Laba Pada Perusahaan Kosmetik Di Bursa Efek Indonesia (BEI)", Badan Penerbit UBH, Padang.
- Darsono dan Ashari. 2005. "*Pedoman Praktis Memahami Laporan Keuangan*". Yogyakarta: Andi.
- Adisetiawan, R. 2012. "Analisis Pengaruh Kinerja Keuangan dalam Memprediksi Pertumbuhan Laba". *Jurnal Aplikasi Manajemen*. Vol. 10 No.3.
- Taruh, V. 2012. " Analisis Rasio Keuangan Dalam Memprediksi Pertumbuhan Laba Pada Perusahaan Manufaktur Di BEI", *Jurnal Pelangi Ilmu*. Vol. 05 No. 01.
- Wibowo, Hendra Agus, Pujiati, Diah. 2011. "Analisis Rasio Keuangan Dalam memprediksi Perubahan Laba Perusahaan Real Estate dan Property di Bursa Efek Indonesia (BEI) dan Singapura (SGX)", *The Indonesian Accounting Riview*, Vol. 1, No. 2 : 155-178.

Cognitive Dissonance of Online Socialization among Tertiary Students

Aiza Johari, Adib Sarkawi, Awang Rozaimie Awang Shuib, Azlina Bujang and Zainon Haji Bibi

Universiti Teknologi MARA (Sarawak), Malaysia, aizajohari@yahoo.com

ABSTRACT

Social networking sites (SNS) are designed to ease online information sharing and enhance information sharing among people, and the sites also relate to socio-cultural, academic, entertainment, educational and business domains. From teaching and learning perspectives, SNS increase comprehension effectiveness and allow faster information accesses. Today, tertiary students' lives are synonymous with network connectivity. This paper argues that socializing online could affect interpersonal relationship among them. A sufficient cognitive dissonance is required to prevent cyberspace addiction. Hence, the study investigates the extent of SNS that affects academic enhancement among the undergraduates. Their levels of awareness on the potential risks of social networking are also identified. The finding revealed that majority of the respondents found that social networking sites are necessary (especially Facebook). They spent more than half of their daily routine being online. Most of the respondents were also aware of potential risks of SNS. Therefore, self-discipline and self-awareness regarding the risks of social networking sites are crucial to enhance their potential values.

Keywords: Social networking, cognitive dissonance, tertiary students.

I INTRODUCTION

Online socialization is the connection effort made at social websites via Internet and other mobile devices. The effectiveness of online social connectedness is supported with advancement in communication medium, especially the Internet and mobile devices such as Smartphone, notebook, tab and such. Undeniably, information technology plays an increasingly important role in people's life and its significant role inevitably has influenced the escalating number of users from all over the world. The popularity of online social networks has created a new world of communication where social networking sites (SNS) have become integrated into daily social lives and routine including the tertiary education students. In Malaysia, the adoption of SNS has increased in the last few years in conjunction with the progress and development of iPad, iPhone and the like, facilitating easy access anytime and anywhere for

the search of information (Saodah & Norealya, 2015).

Despite its escalating popularity, there are complaints among academia that their students pay less attention to the in-class lectures. The students are interrupted by the online 'alerts' and updates in their 'smart' mobile phones. A market research by GFK Asia (2013) reported high consumer demands for Smartphone and basic features phone in the Southeast Asia region. Increasing mobile phone sales, especially among 7 key markets in the region such as Singapore, Malaysia, Thailand, Indonesia, Vietnam, Cambodia and the Philippines are also reported. Sales increment in 2013 accounted for over 118 million units. Malaysia and Singapore show some penetration levels of Smartphone with more affordable price range of USD100 to USD200. It is believed that teenagers are major contributors to the sales of Smartphone increment.

At the edge of technological expansion, it seems that today's youths often face social-psychological problem affected by internet and other online socialization activities. Social-psychological problems include: the internet addiction disorder, mental disorder (depression, anxiety, and mood swing), a serious health problem or disability, or a social relationship problem. High intensity of time spent online might interrupt their daily life, works and relationships. Misused source of information through the internet is violated by online games, gambling, cybersex and cyber-relationship addiction, or compulsively surfing in the social networking at the Facebook and other android apps such as Instagram, WhatsApp, Foursquare, Flickr, Tumblr and Twitter.

Milanovic (2015) affirmed that "social networking" is not new – ever since there have been humans, as they constantly look for ways to connect, network, and promote with one another, until SNS has taken new and momentum in the digital age. As a result, many technological risks might occur if youths are not aware of the adverse effects of SNS, as well as not practicing caution when utilizing them. Some of online social networking risks concern include inadvertent disclosure or personal information, damaged reputation due to rumors and gossip, unwanted contact and harassment or stalking,

surveillance-like structures due to backtracking functions, use of personal data by third-parties, and hacking and identity theft (Boyd & Ellison, 2008).

In addition, online addiction among university students affects learning environment where they spend more time checking, updating and communicating in social networking sites rather than completing their academic tasks. Losing focus and low academic performance called the study to investigate the utilization of social networking among undergraduates. The undergraduates' cognitive dissonance and awareness towards potential risks of social networking were also identified. Thus, underlined by the theory of Cognitive Dissonance, the present study investigated the extent of online socialization (attitudes) which affects students' SNS utilization (cognition).

II LITERATURE REVIEW

A. Online Connectivity

The internet is perceived as open technological-based sources for information on economic, politic and social-cultural access and sharing. Subrahmanyam and Lin (2007) and Subrahmanyam and Greenfield (2008) asserted that the internet becomes synonymous with daily social life among adolescents and emerging adults. Even so, high intensity of internet connectivity might cause internet addiction where it causes detrimental outcomes for young people that may require professional intervention (Kuss et al., 2013). Many users might find the Internet to be entertaining, interesting, interactive and satisfactory, but the heavy use of Internet had caused dependency and other psychological intolerance.

Concern over online socializing and psychological issues arise where internet addiction might affect the psycho-socio development and pose physical health-threatening risks to the students. In addition, addicts have high tendency to access internet, where being offline, they often face loneliness, depressed mood and compulsivity, be more vulnerable to interpersonal dangers and showing an unusually close feeling for strangers (Whang et. al, 2003). Hence, cognitive consistency is vital to reduce dissonance behaviors affected by SNS addiction. Amerio, Bosotti and Amione (1978) proved that dissonance reduction among children could be achieved with internalized norm of self-awareness.

B. Cognitive Dissonance

The theory of cognitive dissonance (Festinger, 1957) suggested that an inner drive of a person holds the attitude and belief in harmony, and avoid

psychological conflict or dissonance. Thus, the psychological difficulty or cognitive dissonance occurs when a person has conflicting attitudes, beliefs or behavior. Feeling of discomfort and disorder might be the impacts of undergraduates' addiction to online socialization activities. Cognitive dissonance might affect others too, due to the comfort imbalance of beliefs and attitude of a person. For example, the students are aware that addiction to being online (behavior) aggravates further addiction and makes them lose focus on their study and other curricular activities (cognition), but most of them still could not resist being online. Thus, their mental well-being and attitudes may alter due to the external influences within the person. A critical dissonance occurs when a person is being forced to perform an action that is inconsistent with their belief. Hence, a person may show rebellious or other unpleasant behaviors after being notified by the others to reduce or stop the inappropriate cognition. Festinger and Carlsmith (1959) suggested that inappropriate behavior or dissonance can be reduced by re-evaluating the attitude.

Dissonance experiences are unpleasant and may jeopardize interpersonal relationship and other psychosocial conflict (Rotsztein, 2003). Amerio et. al, (1978) and Balakrishnan and Shamim (2013) mentioned that a person or others in-companion are motivated to reduce and eliminate sign of disagreement in order to achieve a mutual consonance. Psychological conflict of dissonance often leads to uncertainty, which entails affirmation (Randles, Inzlict, Proulx, Tullett and Heine, 2015). Fortunately, with proper monitoring and restraint, socializing online could give more positive impacts such as creating learning community via interactive academic online discussion or e-learning. Consistency between attitudes and behavior is important to ensure maximum use of internet, and other social medium for academic performance enhancement among tertiary education students.

C. Valued Features of Social Networking Sites (SNS)

Boyd and Ellison (2008) defined SNS as 'web-based services that allow individuals to construct a public or semi-public profile within a bounded system, articulate a list of other users with whom they share a connection and view and traverse their list of connections and those made by others within the system'. In relation to the significance of SNS to students, Cheung and Chiu (2011) affirmed that understanding why students use online social networking sites is crucial for the academic

community, as this new communication platform exhibits important impact on students' motivation to learn to produce affective learning, and classroom climate (Mazer, Murphy & Simonds, 2007). Furthermore, social media sites also creates networks or social relationships among students, in which these sites enable any kind of information sharing activities such as sharing interests, business endeavours and current issues (Saodah & Norealya (2015). Besides, virtual community can generate new ideas through responding and exchanging content, which reinforces dynamic content creation (Quan-Haase & Young, 2010). With regards to Facebook, Balakrishnan and Shamim (2013) claimed that it was the choice among Malaysian students for social networking, psychological benefits, entertainment, self-presentation and skill enhancement.

D. Possible Risks of Social Network Sites (SNS)

There is no doubt that SNS have gained their beneficial values when they are able to widen many people's horizons. Nonetheless, there have been many risky circumstances as reported by media of SNS users were being bullied and deceived or even cases of group suicide. Federal Communications Commission (2009) shared some of the risks associated with the use of social media such exposure to inappropriate content (offensive language, sexual content, violence or hate speech), harassment, sexual predation, fraud and scams, failure to distinguish between who can and who cannot be trusted when sharing information, compromised privacy and exploitation to exploitative advertising.

Reports by Commonwealth Joint Select Committee on Cyber-Safety (2010) and Internet Society (2012) further informed that the nature, prevalence, implications of and level of risk associated with cyber-safety threats are such as use of children online (cyber-bullying, cyber stalking and harassment), exposure to illegal and inappropriate content, inappropriate social and health behaviours in an online environment (technology addiction, online promotion of anorexia, drug usage, underage drinking and smoking), disclosure of personal information and data theft and breaches of privacy. As such threats and risks are on the rise, SNS users should be able to make full use of SNS by boosting their valued features and preventing their potential risks. Discussed earlier, there are various psycho-social problems and internet threats that might affect students due to the high involvement of SNS (Rotsztein, 2003; Young, 2004; Byrne, Dvorak, Peters, Ray, Howe & Sanchez, 2016).

III METHODOLOGY

Recognising the attitudes and identifying online socialization behaviours among local university undergraduates in Sarawak are the main objectives of the present study. A survey questionnaire was designed to which the items were adapted from the study by Chou (2001) on the internet addiction among Taiwanese college students. Attitudinal elements were measured through the students' awareness towards SNS risks including: multiple SNS membership, the necessity of SNS in students' lives, daily frequency in utilising SNS, their preferred SNS, the valued features when utilising SNS and how the respondents set their profiles in SNS accounts, utilizing the five-level Likert scale. The behavioural aspect was also measured through the students' online social network usage, using two-level Likert scale.

Convenient sampling technique was used to recruit the respondents where they were the students who often assembled (between classes or during lunch hours) at the Students' Centre of the university. That spot provides free and high-speed e internet connectivity (WiFi), hence making it is a popular meeting point among students. 120 students agreed to administer the questionnaire with 33% of response rate. 70 sets of usable questionnaires (with less than 30% of missing values) were used for data analyses. For the purpose of arbitrary enquiry, only frequency analyses were performed to identify the percentages of agreement with the measured items; which will be valuable for future investigation and analyses.

IV FINDINGS AND DISCUSSIONS

In view of demographic details, more than half of the respondents were females (60%); aged between 21 and 23 years old (53.3%). This shows that the young adults can afford to have devices (laptop and Smartphone) for their online socialization activities. In addition, 55.7% of the respondents were in their Diploma studies, while the rest were Degree students. The finding also illustrates lighter academic load among diploma level students which might give them more time to conduct online socialization activities. In a verbal communication between the researchers and 44.2% of degree students, their online socialization involvement was secondary activity.

The following Table 1.0 reports the undergraduates' networking (SNS) profiles. The respondents' agreements to the statements are accessed to identify their motivation, involvement and awareness to any socialization risks.

Table 1.0. Networking (SNS) Profiles

Items	Values	Frequency	%
1. Member of multiple SNS	Yes	47	66.7
	No	23	33.3
2. SNS- a necessity in everyday life	Yes	56	79.3
	No	14	20.7
3. Daily frequency of SNS utilization	< 1 hour	9	13.3
	1 – 2 hours	21	30.0
	2 – 3 hours	12	16.7
	> 4 hours	28	40.0

It is not surprising to know that 66.7% of respondents were having multiple SNS account, in which they gained access to various social networking sites such as Facebook, Twitter, MySpace and many other social networking website accounts. This finding is in-line with the study by Zwart, Lindsay, Handerson and Phillips (2011) where most of students at the Victorian High School in Australia admitted that they were active members of few SNS such as Bebo, Tumblir, Twitter, MySpace and Facebook. Particularly, among many types of online socialization sites, Facebook was the most preferred or favourite site (93%) among students. According to Subramaniam (2014), Facebook is the most visited SNS with 10.4 million users, of whom 3.5 million are youths between 18 and 24 years old, i.e., those of studying age. Likewise, Sensis Social Media Report (2015) also reported that Facebook continues to dominate the social media space, capturing 93% of users where they spend an average of eight and a half hours a week on the site.

In dealing with necessity of SNS in daily life, 79.3% of respondents acknowledged the importance of social networking sites in their everyday life. The result reflected the intensity of the respondents who used SNS as a main mode of their communication daily. Updating status, location and activities are considered as routine to ensure their friends and family members are notified. With minimal monthly subscription fees to the network connection, communication through SNS is considered effortless, economical and unlimited to inform and being informed. This result is in line with the result in Debatin et al. (2009) which indicated assimilation of SNS usage into daily routine for most of Victorian middle school students. Notably, 20.7% of the respondents perceived SNS as necessary activities during their spare time.

Consequently, the results have shown 40.0% of the respondents had spent more than 4 hours of their daily routine utilizing the SNS. In average, the undergraduates spent 4 to 8 hours daily (weekdays) for lectures, tutorial or laboratory works. Informal chat between the researchers with the respondents indicated that SNS activities are continued even

during lectures, tutorial or laboratory works due the ‘need’ to check the updates ‘and replying the posted messages and information on the SNS. To add, 30.0% of respondents spent between 1 to 2 hours daily on SNS, while 16.7% of respondents utilized between 2 to 3 hours daily over SNS. Nonetheless, 13.3% of respondents claimed that they utilized SNS less than an hour daily. In general, the result shows that a majority of the respondents who had several SNS possessed cognitive dissonance in response to the imbalance of attitude and behavior. The students were aware of the danger of SNS addiction (cognition) but they were unable to avoid the systems (attitude). They realized that they could turn up to be internet addicts, but they were unable to resist its temptation. The result gave further support to the consonance argument by Amerio et. al, (1978) and Rotsztein (2003) on the motivation and cognitive agreement, as well as Randles et al. (2015) on knowledge affirmation.

Table 2.0. Reasons of Online Socialization Activities (Consonance Behaviours-SNS)

Reasons of SNS (Items)	%				
	S.D	D	N	A	S.A
To search for information		1.4	8.6	28.6	61.4
To get information	1.4	1.4	12.9	24.3	60
To keep in touch with friend			4.3	21.4	74.3
To find new friend	1.4	1.4	4.3	28.6	64.3
To share experience			21.4	35.7	42.9
For education purpose	2.9	14.3	35.7	35.7	11.4
To stay up-to-date	1.4	4.3	21.4	37.1	35.7
For entertainment		2.9	7.1	12.9	77.1
For gaming purpose	2.9	15.7	15.7	30	35.7

*S.D: Strongly Disagree; D: Disagree; N: Neutral; A: Agree; S.A: Strongly Agree

In searching for the balance of cognitive dissonance among undergraduates, the respondents had given various agreements to the reasons of online socialization. In line with studies by Balakrishnan and Shamim (2013), several motives to SNS are adapted to identify attitudes over SNS. First, 61.4% of respondents strongly agreed to the motives of SNS utilization are for information searching either for academic purposes or general knowledge. Second, 60.0% of respondents strongly agreed that utilization of SNS is to extract relevant information for their academic writing. Third, 74.3% of respondents used SNS to continuously connect with friends. Fourth, SNS is utilized to find new friends (for social networking, support and share interest) as strongly agreed by 64.2%. Additionally, 42.9% of respondents utilized SNS to share experience with the others. The respondents indicated that experiences and information sharing involved jokes, news updates, knowledge findings, general information, feelings and opinions or argument on certain subject matters.

Sixth, moderate agreement was found among the undergraduates on the use of SNS for academic or education purposes. The respondents perceived SNS as neutral where they balanced the use between academic and non-academic purposes. Slight portion of the respondents agreed that SNS was beneficial for education purposes with 35.7% of agreement. Notably, it can be generalised that the main reasons of the respondents to utilise SNS were for social communication and interpersonal networking purposes. This result gave further support to a study by Cheung and Chiu (2011) where social presence has the strongest impact on the intention of using Facebook in order to gain instant communication and connection with their friends. Seventh, 37.1% of respondents agreed that the use of SNS was to stay connected or up-to-date with news, information, gossips and other social notification (such as reunion, meetings, discussion or dating). Eighth, majority or 77.1% of respondents strongly agreed that the use of SNS were for entertainment purposes. Some SNS provide easy access and updates to the screen play, especially YouTube and other website of 'fan club' to particular celebrities, dramas or movies. Lastly, as youths, 35.7% of respondents strongly agreed that SNS utilization was for gaming purposes. Online gaming or downloading the software to play offline is also the reason of joining online socialization activities.

Table 3.0. Awareness of Potential Risks

Questions	Values	Fr	%
1. How do you set your profile in your SNS accounts?	Restricted access	50	71.4
	Open to public	20	28.6
	Total	70	100
2. Do you know the potential risk(s) of using SNS?	Yes	55	78.6
	No	15	21.4
	Total	70	100

*Fr: Frequency

The respondents were generally aware of the risks or social violence on the use of SNS where 71.4% of respondents apply some access of restriction on their personal information in the SNS. The respondents created restricted access to the personal profile by using password or allowing only certain 'friends' to view their personal information. However, 28.6% of respondents revealed their personal information to public views. This is an example of cognitive dissonance among students on the internet addiction as claimed by Amerio et. al, (1978), Chou and Hsiao (2000), Rotsztein (2003), and Whang et. al, (2003). By reviewing SNS privacy policy, SNS users at least have some knowledge pertaining to data security and information protection. When the students have certain level of awareness, they will take precaution by restricting some personal information access (in their SNS account) and being more selective to

choose viewers of their profiles. Consonance or balancing of behavior is revealed from the result, where most of the respondents were aware of SNS risks and their privacy rights. Utilization of online materials gives vital impression that virtual knowledge is the most dependable and affordable source of information among today's university students. Hence, further issues worth to investigate is the extend on how virtual knowledge can be manageable, reduce dissonance and affirm certainty, as posited by Randles et al. (2015) and Byrne et al. (2016).

In addition to the access restriction, 78.6% of respondents acknowledged the potential risk(s) of using SNS. The SNS risks or violence include: bullying, harassment, identity theft, inappropriate content, privacy issues, information exploitation and so forth. As suggested by McLeod, one of the methods to reduce dissonance is to acquire new information where SNS users need to update their knowledge regarding internet security. However, 21.4% of the respondents were unaware of such risks. Byrne et al. (2016) shows that online exposure, internet threats and related risks create dissonance which depends on the characteristics of individual user. To sum, the findings of this study identify moderate balance between attitude and cognition among undergraduate students with regards to online socialization issues.

V CONCLUSION

The present study comprehends the cognitive dissonance implication on the use of online socialization among tertiary students in Sarawak. As argued by scholars (Subrahmanyam & Lin, 2007; Subrahmanyam & Greenfield, 2008), Balakrishnan & Shamim, 2013 and Randles et al. (2015); the inappropriate use of the internet and SNS affects the cognitive dissonance and might cause psychological disorder (loneliness, salience, loss of control, withdrawal, and relapse and reinstatement). However, the findings of the present study indicate that most of respondents were in control of their attitudes over SNS and possessed sufficient cognition to online socialization risks and dangers. The most significant finding is: the cognitive dissonance among young adults towards SNS is manageable where a balance between the attitude and cognition is achieved. The findings of the present study also give further prop up to the cognitive consistency in social behavior as suggested by Amerio et. al, (1978) and Randles et al. (2015).

Though the internet is perceived as a significant medium of communication and socialization where it offers unlimited opportunities for learning, knowledge, information and other online activities, SNS users need to be aware of their potential risks and threats. The findings of this study provide useful insights on how tertiary students utilized social networking sites as well as their awareness on the possible incorporated risks of SNS; in-line with findings in the study by Byrne et al. (2016). The results also indicated that many of the students were frequent daily users of SNS and they owned more than one account of SNS. Besides, the overwhelming majority preferred Facebook where the most highly valued features of SNS were the abilities to socialize (to stay connected with friends and to acquire new friends) as well as to gain access to information.

Though many of the students practiced a certain degree of caution in utilizing SNS, they should be able to balance their time between social media and studies so that their academic achievements are not affected. As privacy concern is not well understood by many younger SNS users, self-discipline and self-awareness regarding the risks of social networking sites are also vital to enhance the benefits of SNS use and to minimize the negative implications. There are still subjective issues of cognitive dissonance to unwrap and it remains to be among the issues of online socialization. Nonetheless, young people need to be equipped with the necessary knowledge to efficiently manage their SNS accounts and to cope with potential risks associated with everyday use of SNS.

REFERENCES

- Amerio, P., Bosotti, E., & Amione, F. (1978). Cognitive Dissonance and Internalization of Social Norms: Effects of Threat Severity on Children. *International Journal of Behavioral Development*, 1(4), 355-362.
- Balakrishnan, V., & Shamim, A. (2013). Malaysian Facebookers: Motives and addictive behaviours unraveled. *Computers in Human Behavior*, 29(4), 1342-1349.
- Boyd, D. M., & Ellison, N. B. (2008). Social Network Sites: Definition, History and Scholarship. *Journal of Computer-Mediated Communication*. Retrieved on 9 November 2011 from <http://jcmc.indiana.edu/vol13/issue1/boyd.ellison.html>
- Byrne, Z. S., Dvorak, K. J., Peters, J. M., Ray, I., Howe, A., & Sanchez, D. (2016). From the user's perspective: Perceptions of risk relative to benefit associated with using the Internet. *Computers in Human Behavior*, 59, 456-468.
- Cheung, C. M. K. & Chiu, P.Y. (2011). Online Social Networks: Why do Students Use Facebook? *Computers in Human Behavior* 27(4).
- Chou, C. (2001). Internet heavy use and addiction among Taiwanese college students: an online interview study. *CyberPsychology & Behavior*, 4(5), 573-585.
- Chou, C., & Hsiao, M.-C. (2000). Internet addiction, usage, gratification, and pleasure experience: the Taiwan college students' case. *Computers & Education*, 35(1), 65-80.
- Commonwealth Joint Select Committee on Cyber-Safety (2010) Terms of Reference. Retrieved on 12 February 2012 from <http://www.aph.gov.au/house/committee/jssc/tor.htm>
- Debatin, B., Lovejoy, J. P., Horn, A. K., & Hughes, B. N. (2009). Facebook and online privacy: Attitudes, behaviors, and unintended consequences. *Journal of Computer-Mediated Communication*, 15(1), 83-108.
- Federal Communications Commissions (2009) In the Matter of Empowering Parents and Protecting Children in an Evolving Media Landscape. Notice of Enquiry.
- Festinger, L. (1957). *A Theory of Cognitive Dissonance*. Stanford, CA: Stanford University Press.
- Festinger, L., & Carlsmith, J. M. (1959). Cognitive consequences of forced compliance. *The Journal of Abnormal and Social Psychology*, 58(2), 203.
- GFK Asia (2013) <http://www.gfk.com/news-and-events/press-room/press-releases/pages/gfk%20asia%20-%20southeast%20asia%20mobile%20phones%20market%20grew%20by%2024%20percent%20in%20volume%20over%20the%20last%2012%20months.aspx> Retrieved on 25 February 2013.
- InternetSociety(2012) Children and the Internet.<http://www.internetsociety.org/sites/default/files/bp-childrenandtheinternet-20129017-en.pdf>. Retrieved on: 12 March 2016.
- Kuss,D.J.; van Rooij,A.J.; Shorter,G.W.; Griffiths,M.D. & van de Mheen, D. (2013)Internet addiction in adolescents: Prevalence and risk factors//internetscience.nl/wp-content/uploads/2013/06/Kuss-et-al-2013-Internet-addiction-in-adolescents-Prevalence-and-risk-factors.pdf.Retrieved on 13 May 2016
- Mazer, J.P.; Murphy, R.E. & Simonds, C.J. (2007) I'll See You on Facebook: The Effects of Computer-mediated Teacher Self-disclosure on Student Motivation, Affective Learning and Classroom Climate. *Communication Education*, 56
- McLeod, S. (2014) Cognitive Dissonance. www.simplypsychology.org/cognitivedissonance.html. Retrieved on: 14 April 2016.
- Milavonic, R. (2015) The World's 21 Most Important Social Media Sites and Apps in 2015.<http://www.socialmediatoday.com/social-networks/2015-04-13/worlds-21-most-important-social-media-sites-and-apps-2015>. Retrieved on: 11 May 2016.
- Quan-Haase, A., & Young, A. L. (2010). Uses and gratifications of social media: A comparison of Facebook and instant messaging. *Bulletin of Science, Technology, and Society*, 30(5), 350-361.
- Rotsztein, B. (2003). Problem Internet use and locus of control among college students: Preliminary findings, 35th Annual Conference of the New England Educational Research Organization.
- Saadah Wok & Norealya Misman (2015) Matching Types of Social Media Sites (SNS) to Motives and Profiles of Youths in Malaysia.*Pertanika J. Soc. Sci. & Hum.* 23 (S): 169 – 186 (2015)
- Sensis Social Media Report (2015) Sensis Social Media Report May 2015. www.sensis.com.au/socialmediareport. Retrieved on 25 May 2016.
- Subrahamayam, K & Lin, G. (2001) Adolescents on the Net: Internet Well-being. *Adolescence*. 42
- Subrahamayam, K. & Greenfield, P.M. (2008) Communication Online, Adolescent Relationships and the Media. *The Future of Children* .Children and Media Technology. 18
- Subramaniam, B. (2014). On the social media circuit. *The Star Online: Education*. Retrieved October 7, 2014from <http://www.thestar.com.my/News/Education/2014/01/05/On-the-socialmedia-circuit/>
- Whang, L. S.-M., Lee, S., & Chang, G. (2003). Internet Over-Users' Psychological Profiles: A Behavior Sampling Analysis on Internet Addiction. *CyberPsychology & Behavior*, 6(2).
- Young, K. S. (2004). Internet Addiction: A New Clinical Phenomenon and Its Consequences. *American Behavioral Scientist*, 48(4), 402-415.
- Zwart, M.D.; Lindsay, D.; Henderson, M. & Phillips, M. (2011) Teenagers, Legal Risks and Social Networking Sites. Monash University. Retrieved on 10 March 2012 from www.victorialawfoundation.org.au

Developing Knowledge Asset Valuation Model using Knowledge Experts

Wong Man Wai, Ammuthavali Ramasamy, and Marini bt Othman

Universiti Tenaga Nasional(UNITEN), Malaysia, calebmw@yahoo.com; {ammutha; marini}@uniten.edu.my

ABSTRACT

Knowledge assets which relate to an organization's core business can ensure its competitive edge in business competition by transforming knowledge into goods and services. However unlike physical asset, Knowledge Asset is intangible and there are inadequate techniques to measure the Knowledge Asset. The value of the Knowledge Assets varies, depending on human cognition and awareness which includes context sensing, personal memory and cognitive processes. The aim of this research is to interpret the value of the Knowledge Asset into a meaningful and tangible way. The objective is to develop a model that defines the value of Knowledge Assets. The research approach used is a qualitative single case research. The research has begun with a literature review, document study and interview for information gathering. The findings from the literature review reveals existing framework or model which applied to measure intangible asset. Whereas the document study reveals the factors that triggered event to create, review, update and dispose the Knowledge Asset. This information is used as a foundation to develop the conceptual model. Interviews were conducted and the model presented to the Knowledge Management manager and Knowledge Engineers to collect feedbacks about the conceptual model. As the result, the proposed model enables the Manager and Knowledge Engineers to use the identified factors to value the Knowledge Assets easily and interpret its value into more meaningful and tangible way.

Keywords: Knowledge asset, Value of Information, Valuation model, Knowledge management

I INTRODUCTION

Organizations are transforming business model into knowledge based core competence because knowledge asset is essential in designing and performing business processes efficiently and effectively. It is vital to have knowledge asset for sustaining competitive advantage. But due to the nature of knowledge assets which are intangible and misconception that they are not important causing organizations to lose their valuable knowledge assets unintentionally. This may cause the organization to lose its productivity and creativity in business

process which will lead to loss in competitive advantage.

Knowledge assets are important as physical and financial assets. It allows organization to design and perform business processes efficiently and effectively. Also increases the possibility to create new products and services to enable a business to create its value. Organizations are aware that it is difficult to determine the actual value of knowledge assets in tangible way. How to determine the loss of the organization if their experience knowledgeable workers leave the company? What is the cost to discover, capture new knowledge and transfer to the employees? A framework that is able to interpret the values of knowledge assets into monetary term will help the organization to understand the importance of their knowledge assets in a tangible way, allow them to determine the essential knowledge which requires to support organization business process from time to time and manage knowledge assets more effectively. The paper is organised as follows. The Related work section defines Knowledge Assets in detail and several methods of measuring intangible assets are discussed. Methodology section describes data collection instruments and procedures. Analysis Section describes the result of analysis and interpretation of the collected information. Model Development Section proposed the model of this research based on result generated from Analysis Section. Conclusion contains concluding remarks.

II RELATED WORK

InvestorWords.com defines "Asset" as "Any item of economic value owned by an individual or corporation, especially which could be converted into cash." This is including current assets (liquid cash), long-term assets (real estate, equipment), prepaid and deferred assets (insurance, interest), and intangible assets (trademarks, patents, copyrights, good will).

Knowledge is intangible and varies towards human cognition and awareness. It is a combination of context sensing, personal memory and cognitive processes. To measure the Knowledge Asset also means to put value on people, both as entities and their collective capability (Skyrme, 1999). Unlike physical asset which has time span, Knowledge Assets existence can last forever. One good example

is the knowledge of aerodynamics. Sir George Cayley discovered and identified four aerodynamic forces of flight – weight, lift, drag and thrust in 18 century and the knowledge has been utilized for three centuries. Another good example is the law of motion which is discovered by Newton that standardize of measuring in terms of mass length, and time which has been used for more than three hundred years (Boisot, 1998). From the examples above, we can say that knowledge itself is not perfect (and it will never be) but it will continue to evolve and grow by going through series of experiments, trial and errors bringing best solution at that moment of time.

Snowden has further elaborate 5 types of Knowledge as below (Snowden, 2000):

Table 1. Types of Knowledge

Types of Knowledge	Description
Artefacts	Result of knowledge captured and codified which includes documents, database and processes.
Skills	Combination of set of movements which follow in sequence to make a smooth, efficient feat in order to complete a task. It is acquires through series of training
Heuristic	Technique that has been mastered for problem solving, learning, and discovery which enable a person speed up a process. Maybe referred as “rule of thumb”
Experience	It is job dependence and exercised to perform a task, which many refer as “hands on experience”
Natural Talent	Unmanageable. The best method is to discover the talent and develop it whenever possible by providing chances to individuals to put their talents to best use

Measuring the value of intangible asset such as Knowledge Asset has never been an easy task (Kaplan, 2004). First of all, the value of the intangible assets are subjective, the worth of intangible assets varies in different people. In an oil company for an example, it is very important for a retail firm to get hold of retailers as it can ensure the oil company could sell out smoothly; but to the Customer Service Department in the same company, they give more value to the customer service quality and satisfaction more than retailer. Second, the intangible assets are almost no value by themselves;

they need to be combined with other assets in order to realize their full potential. A good example like investment in IT has little value unless it is complemented with HR training, the IT investment and HR training must be incorporated and associated with corporate strategy in order to realize their full potential. Third, the impact of the intangible assets to financial performance is not immediate. For an instance, providing training Total Quality Management and Six Sigma could improve the process quality and to improve customer satisfaction and loyalty. However the investment of the training will be paid off if only the company is able to transform customer satisfaction and loyalty into financial benefits from the sales.

Despite the challenges mentioned above, it is still very crucial to recognize intangible assets as the tangible assets. Thus different frameworks have been developed to attempt measuring intangible assets which is discussed briefly in the Table 2.

Table 2. Intangible assets measurements

Intangible assets measurements	Developed	Description
Intangible Assets Monitor	Karl-Erik Sveiby	It measures the intangible asset by using table that classified employee into three categories: Competence, Internal Structure and External Structure. Each category is measured with four perspectives: Growth (e.g. number of years in the profession.), Innovation (E.g. new concept or ideas development), Efficiency (E.g. value added per professional) and Stability (E.g. average of employees) of intangible assets.
Skandia Navigator	Edvinsson	Provides a holistic view based on performance and goal achievement. It is used to measure the Intellectual Capital and Knowledge Assets of the company.
Meritum Guidelines		Consists of three phases. The first phase is to guide company to identify the vision of the company; In the second phase, the

		company needs to identify the intangible resource which is aligned to their strategic objectives and the activities that could affect the intangible resources; Finally, a system of indicators will be used to assess how well the company is fulfilling its objectives.
Danish Guideline		Designed based on four elements: Knowledge Narrative, Management Challenges, Initiatives and Indicators which represents the analysis of the company's KM in the Intellectual Capital statement

These models have different approaches to measure the intangible assets but they share two common actions while defining the measurements:

1. Discover factors to be measured.
2. Define performance measures for the identified factors.

These actions are the foundation in measuring performance of the intangible assets. In general point of views, factors are related to objectives of the company where quality performance must be performed. Meanwhile to define performance measures to identify factors is to serve as benchmarking of the performance. Based on the purpose of the measurement; the result of the benchmarking could be used to control, motivate and guide the company. Figure 1 below is a common state of four models in managing factors into measurement.



Figure 1. Flow of Managing Factors into Performance Measurement

III METHODOLOGY

This research focused on studying the current practices to valuation of Knowledge Assets at Company A. It investigated the possibility of implementing new method to measure value of Knowledge Asset and developed a model that defines and reflects the value of the Knowledge Assets. The study started off with existing process that measures the Knowledge Asset at Company A and identified the factors which were initiated to create, maintain

and dispose Knowledge Script. To accomplish these, an interview was conducted with Operation Support Office's (OSO) personnel and reviewed documents which are related for analysis. Also, identified the events which triggered to create, maintain and dispose the Knowledge Scripts which assisted in developing model to value the Knowledge Asset. The model practiced by Company A was compared to other models to identify the gap and opportunities which was used to implement new model.

For data gathering, an interview method was used through the development of a series of semi-structured interview questions related to the units-of-analysis. This method was chosen in order to have a better guide and produce a more informative interview session. This involved the use of multiple data collection methods such as data, methodological and interdisciplinary triangulation (Yin, 2009; Denzin, 2000).

In addition to the interviews, data was collected through several other sources such as archival documents, minutes of meetings and consultancy reports. Eisenhardt suggests that the usage of multiple data collection methods supports triangulation and provides a concrete and solid foundation of theory. Interviews shall be recorded and transcribed. A copy of the transcription shall be provided as soon as possible after each interview for further verification (Eisenhardt, 1989).

Concept model was developed based on understanding of the process and procedures which were undertaken in the managing knowledge scripts at the Company A. Development of the model was required to support evaluation of knowledge assets of the organization. A model was used to interpret the value of the knowledge assets in currency to provide significant ways to view the knowledge assets similar to the physical asset in an organization. The model should be able to generalize the cost of the knowledge including i) identified knowledge; ii) preserved knowledge; iii) foster the growth of knowledge and updated frequently iv) knowledge sharing. Later, the concept model will be reviewed by Knowledge Engineers (KE) and Subject Matter Experts (SME), their feedbacks and opinions of the concept model became the references on improving the model before it was proposed.

IV ANALYSIS

The single case study analysis technique is used to present and to analyze the information which is collected from Company A. This research has

selected Company A's Operation Support Office (OSO) as a case study for the process of managing Knowledge Scripts in order to develop a model that values the knowledge scripts.

Company A is a multinational Corporation which provides IT and business process outsourcing, professional services such as management and technology consulting. OSO is actively involved in activities within Knowledge Management (KM) such as to create, update, review and retire knowledge scripts. Their role is to ensure a completed, timely and accurate knowledge script which stored in the Knowledge Repository and to ensure the availability to those who requires knowledge to solve the IT related issue.

The current process has involved 7 participants. They are Knowledge User(KU), Knowledge Submitter(KS), Knowledge Owner(KO), Knowledge Administrator(KA), Knowledge Engineer(KE), Subject Matter Expert(SME), and Knowledge Publisher(KP). Table 3 provides the summary of roles and responsibilities for each participants.

Table 3 Roles and responsibilities for each participants

Reviews - Approves	Legends						
Contributes - Performs	Knowledge User	Knowledge Submitter	Knowledge Publisher	Knowledge Administrator	Knowledge Engineer	Subject Matter Expert (SME)	Knowledge Owner
Manage Knowledge							
Create knowledge	P	C					
Review Knowledge						P	C
Retire knowledge		C	P				P
Approve knowledge		C	P	C			
Publish knowledge			C		P		
Update knowledge	P						
Query knowledge							
Authorise all interrogative users and systems						P	
Ensure knowledge base can be queried by systems						P	
Allow query by keyword searches						P	
Filter returned results to allow only records accessible to users						P	
Authorise reporting access						P	

The content of the Knowledge Scripts includes IT related issues, business process how-to, template or format of the document for the documentation purposes and many more. Each Knowledge Script is to display information such as: document ID, problem type, problem description/ scenario/ questions, solutions, and attachment. At the end of the script, users are able to rate the knowledge script, leave comments and mark as request to update the knowledge script.

Based on result of the interviews and documents study, it shows that the company does not value the Knowledge Script, the staffs hardly view the

Knowledge Script as Knowledge Asset, the value of the knowledge scripts is not tangible to the staffs, the task to maintaining the Knowledge Repository has become a hassle and there is no plan in near future to adopt framework or model to evaluate knowledge script.

After comparing to Company A's current practice with the models reviewed in Literature Review Section, few gaps have been identified.

- Factors are not identified to evaluate the Knowledge Script.
- The value of Knowledge Script is not tangible and less visible.
- Company A does not own a measurement system to measure performance of the Knowledge Script.
- Knowledge Users play a major role to evaluate the performance of the Knowledge Script. The result is subjective and does not reflect the actual value of the Knowledge Script.

The findings from the above served as one of the underlying foundation to formulate the proposed model.

V MODEL DEVELOPMENT

The foundation of the conceptual model is derived from the literature review, document study and interview. The purpose of developing the model is to enable the OSO personal to use identified factors to value the Knowledge Assets with an easier way and to interpret its value into more meaningful and tangible way. There are three components in this model: People, the Measurement System and Process, as shown in Figure 2.

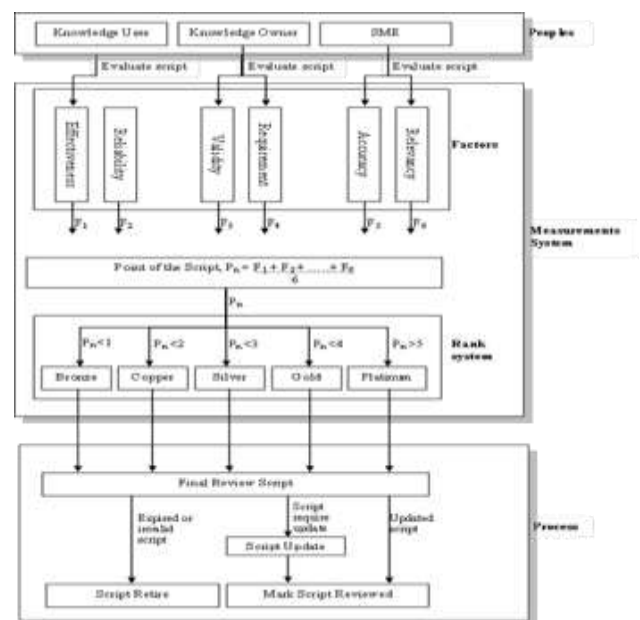

Figure 2 Components of the Knowledge Asset Valuation Model

A. People

Previously, Knowledge Users are the only major role which rates the Knowledge Script. In the new model, there are three participants who play the role to evaluate value of the Knowledge Script:

- Knowledge User – A person who uses the knowledge as part of their daily task.
- Knowledge Owner - The person who contributes and owns the knowledge script.
- Subject Matter Expert (SME) - The person who is an expert of a given Knowledge Script.

The Knowledge User, Knowledge Owner, and SME will evaluate the Knowledge Script according to specific indexes which are used in the value system. The measurements of the value system are derived from the document study where it describes the event of trigger the Process of Knowledge Script Management. Each participant listed at previous subsection People has a different event which triggers the process.

Table 4 Events that trigger by each participants

Participants	Events
Knowledge User	User cannot find any knowledge script in the given area. Problems are not resolved by solutions given in the Knowledge Script.
Knowledge Owner	Identifies that Knowledge Script has expired. New knowledge or business process has been introduced.
Subject Matter Expert	Aware and able to identify the changes of new technology or knowledge. To identify knowledge script is outdated, inaccurate and irrelevant.

Each event listed above is interpreted into factors. These factors are used by participants as the indicator or performance measurement to value the Knowledge Script.

Table 5 Factors valued by participants

Participants	Factors
Knowledge User	Script Effectiveness. Script Reliability.
Knowledge Owner	Script Validity. Script Requirement.
Subject Matter Expert	Script Accuracy. Script Relevancy.

Each factor given has its definitions as listed below;

• Script Effectiveness

To measure the quality of the knowledge script; the solutions returned in the script guides the user on

doing the right things to the achieve objectives and to solve problems.

• Script Reliability

To measure the consistency of the knowledge script; the ability of the knowledge script to perform its function or mission to the solutions which are delivered to users consistently without degradation or failure is concern.

• Script Validity

To measure the validity of the knowledge script in certain period of time; where the solutions of the script are effective and remained in force in the specific timeframe concerned.

• Script Requirement

To measure the necessities of the knowledge script; where the degree of the needs and demands of the script exists to support the business process is concerned.

• Script Accuracy

To measure the precision of the knowledge script; where the details of the script enables user to perform the task or to resolve issue with precision is concerned.

• Script Relevancy

To measure the degree of pertinent between the knowledge script and the problem; where the details of knowledge or solutions of the knowledge script is closely tied with current business process or known issues is concerned.

Each participant can rate the particular factors from scale 1 to 5, the higher value for the better performance. After the knowledge script is evaluated, the performance of the Knowledge Script will be tabulated into a chart shown as Figure 3.

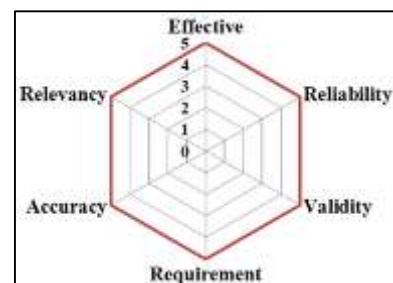

Figure 3 Example of the chart

Next, the total points accumulated from the factors will be averaged. The average points will fit in to the rank listed at Table 6 below.

Table 6 Table of ranking

Average Points	Rank
$0 \leq X < 1$	Bronze
$1 \leq X < 2$	Copper
$2 \leq X < 3$	Silver

$3 \leq X < 4$	Gold
$4 \leq X \leq 5$	Platinum

B. Process

This subsection will illustrate the process of the model. The idea behind of this process was suggested by Knowledge Management Manager and Knowledge Administrator. It is suggested to implement the model in the process where the knowledge script is documented, stored at Knowledge Repository and published to the Knowledge Users. The process is adjusted to fit in the “Evergreen Process”. The process of the model is shown as Figure 4:

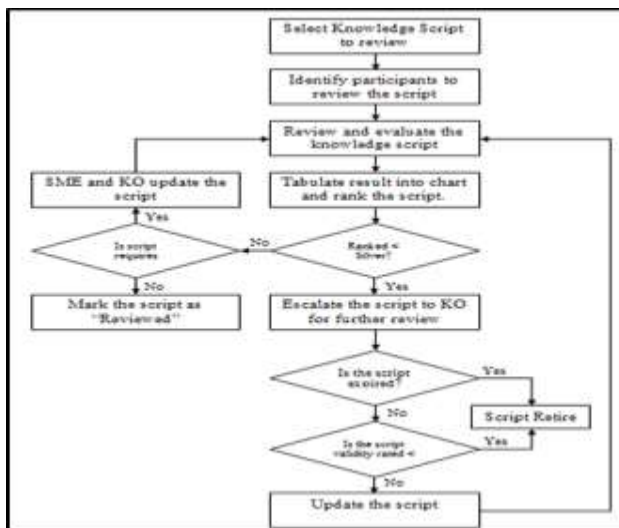

Figure 4. Flow of the process

VI CONCLUSION

Knowledge Assets is one of the valuable assets and crucial for the growth of the companies and enable them to sustain their competitive edge. By understanding the value of their knowledge assets will help the companies to manage and retain their precious knowledge. This research is attempted to provide solution where the knowledge assets can be tagged with value and be recognized by the people. Specifically, the proposed model has given an idea on how to identify the value according to the specific factors, and then magnify the value into charts and its rank. Allow users to view the value of the scripts in more tangible and meaningful way.

The studies have revealed the events which trigger the process to create, review, update, and retire the knowledge script and the roles and responsibilities of participants in each event and the methods used to rate the scripts. This information is analyzed and utilized to develop the model. The second contribution was the development of the model to value the knowledge scripts. The aim of the developed model is to utilize identified factors to evaluate the value of the knowledge script.

Finally this research recommends continuing a further study on this model to expose it to other possible improvement and potential of the model. In this research, it is only to focus on valuing the knowledge scripts. It would be good opportunity to have further research to value other knowledge assets such as skills, heuristic, experience and etc. Also, to conduct further case study with simulation to illustrate how to use the developed model in the working environment and with quantitative elements to increase validity of this research.

REFERENCES

- Boisot, M. H. (1998). *Knowledge assets: Securing competitive advantage in the information economy*. OUP Oxford.
- Danish Agency for Trade and Industry. (2000). A guideline for intellectual Capital Statements - Key to Knowledge Management. Copenhagen.
- Denzin, N. K. and Lincoln, Y. S. (2005). *The Sage Handbook of Qualitative Research*. Sage Publications, Thousand Oaks
- Edvinsson, L. and Malone, M. (1997). *Intellectual Capital: Realizing Your Company's True Value by Finding Its Hidden Brain-power*. HarperCollins, New York
- Eisenhardt, K.M. (1989). Building Theories from Case Study Research. *Academy of Management Review*. 14(4), 532-550
- Kaplan, R.S., and Norton, D.P. (2004). Measuring the Strategic Readiness of Intangible Assets. *Harvard Business Review*, 82(2), 52-63.
- Meritum. (2001) Guidelines for managing and reporting on intangibles. Final Report of the MERITUM Project.
- Skyrme, D. J. (1994). The Knowledge Asset. I3 INSIGHT No 11, David Skyrme Associates. Retrieved from <http://www.skyrme.com/insights/11kasset.htm>, 1999
- Snowden, D. (2000). The ASHEN Model: an enabler of action in Knowledge Management. 3(7), 14-17
- Sveivy, K. E. (2001). The Intangible Assets Monitor. Retrieved from <http://www.sveiby.com/articles/CompanyMonitor.html>
- Yin, R. K. (2009). Case study research: Design and methods 4th ed. In *United States: Library of Congress Cataloguing-in-Publication Data*

The Factors Affecting Knowledge Sharing Behaviour within a Case Study Taiwanese Small Business

Hsing H. Lee

Aletheia University, Taiwan, hsinghsinlee@hotmail.com

ABSTRACT

Organisations need to create, retrieve and distribute new knowledge within their companies before applying it to gain, or maintain competitive business. Additionally, recent research has identified a variety of factors that lead to effective knowledge sharing, such as motivation and culture. Moreover, there is few established body of literature that has identified discernible difference between China and Taiwan. Nearly all of the knowledge management literature is in respect of the cross cultural aspect of modern international business, largely in interactive networking, knowledge acquisition and sharing (Holden, 2002). However, SMEs are recognised to be a distinct industry sector with some characteristic elements of culture that will impact upon knowledge sharing with regard to the stages of creation, transfer, sharing, integration and translation into practice. Factors, including elements relating to cultural perspectives, were discussed arising from the case study of a small Taiwanese company. The research methodology was based on qualitative research and a case study. Given the objectives of the research, in-depth interviews would be necessary to supplement the research. Using constructivist grounded theory this research examined how humans construct reality. It concludes that the organisational context and culture are significant factors that help employees to carry out their tasks. Additionally, the Taiwanese organisational context and how it impacts on interactions between employees and with management, was another important factor.

Keywords: Knowledge sharing, cultural perspective, SMEs.

I INTRODUCTION

Knowledge management (KM) is about making sure that knowledge from employees, teams, and units within an organisation is captured, remembered, stored and share with others. In brief, the KM process can be seen in two ways, either to reuse the existing knowledge through capture, transfer it while encountering the similar situation or to create the new knowledge by sharing and integrating the existing knowledge that through the interactions between people (Alvesson, 2004).

Reviewing the related KM and its process literature review, this paper developed a research model and investigated knowledge creation, transfer, sharing, integration and translation as the knowledge process and identified knowledge sharing as a major focus area for KM.

In addition, the development and practice of KM are often associated with large organisations whilst only a small amount of studies are based on SMEs and/or traditional industries (Wu et al., 2006; Ruiz-Mercader et al., 2006; Wong, 2005; Hsu et al., 2006). However, SMEs play their specific role in the economy and also need to improve competitive advantage through knowledge management (Wong and Aspinwell, 2004). Sparrow (2005) points out SMEs may face different issues from larger organisations whilst engaging in the development process of KM. Moreover, he also suggests that different SMEs may use different approaches towards KM development because of the functions among SMEs are not the same. As a result, SMEs also need and challenge KM as larger organisations do (Lim and Klobas, 2000).

Several researchers indicate organisational culture is the primary element that influences KM. Hence, organisational values are important to facilitate effective knowledge sharing among the employees in the organisation. National culture influences organisational cultural as national culture has the impact on people's perceptions. Therefore, national culture can provide the basic identify and norm towards regarding knowledge sharing behaviours.

The GLOBE project (House et al., 2004) identifies nine cultural dimensions in 62 societies, which includes Taiwan and whilst there are assessments of China, there is few established body of literature that has identified discernible difference between China and Taiwan. Chinese culture possibly dominates the common cultural values for Chinese people no matter where they live (Fan, 2000). Hence, there would be an assumption that the hallmarks of Chinese culture applies to Taiwan.

Specifically, this research investigates what kind of mediating artifacts can facilitate the knowledge sharing behaviours in a case study company in Taiwan. Moreover, the typical Taiwanese behaviours and attitude towards knowledge sharing need to identify.

II METHODS

The research methodology was based on qualitative research. A case study was used to provide a viable, rich understanding of the context of the research and the process being enacted (Yin, 2008). Using constructivist grounded theory this research examined how humans construct reality and discover it from the interactive process, in order to gain depth and understanding in their work.

Data was gathered in several ways included observations, filed notes formal and informal (a quick chat) interviews with the managers and the employees. Moreover, the practice of grounded theory coding was used to be techniques for data analysis process. The research was designed to use case study and qualitative methodology. Therefore, NVivo software provided various tools to find the most suitable way to analysis the data.

The methodology of this research was based on the constructivist mode of grounded theory which was represented by Charmaz (2006). However, it depended on the need of data analysis, axial coding was used to form the categories. As the codes emerged from the data, therefore, free node was used as open coding and tree node was used as axial coding then the core categories were identified.



Figure 1. Organisational Context.

As it can be seen in figure 1 organisational structure category represented the structure of company and the interactions among employees and managers. It has impact on the knowledge process in natural setting context. Namely: communication relationship, leadership and rewards.

As it can be seen in Figure 2 the culture aspects of category were to explore the phenomenon in a natural culture setting under this research, specifically, typical Taiwanese culture. There were seven properties under the category which emerged from the open coding. Namely: goal to achieve, embedded in the group, long term perspective, acceptability towards managing uncertain situation, manager's standpoint, care about the feelings of the subordinates and social interactions.



Figure 2. Cultural Aspects.

III FINDINGS

This section is to explore the finding of the research objective. In analysing the data, two categories emerged: organisational context and cultural aspects.

A. Organisational Context

Organisational context represents a structure of the company and the interactions among employees and managers. Three aspects are under organisational context, namely, communication relationship, leadership and rewards.

Communication Relationship. It refers to the way of communication in the company, whether the information or knowledge went from bottom-up and vice versa. Therefore, horizontal and vertical were two dimensions to look at this aspect.

Nearly all of the participants stated:

“I would ask some help from my colleagues, either the senior ones or who got the specialised knowledge.”

Moreover, some of them addressed:

“Firstly, they would ask help from their colleagues and once they couldn't sort it out they would consult with the manager.”

As a result, when the employees encountered the difficulties, they would ask help from their colleagues, if they couldn't still sort it out then they would turn into the manager. On the other hand, when the manager dealt with unfamiliar things, he or she would ask assist from the subordinate. As the results,

the relationship did go horizontally among the employees and the manager and knowledge went flow from both directions. If knowledge flow goes in both directions, and the contact is frequent, it may lead employees and managers to be more supportive of one another.

Leadership. It refers to the style of managers, either hierarchical or supportive style. Previous research indicates that manager support plays an important role in stimulating knowledge sharing and creating a supportive climate culture.

As management department employee stated:

“Normally, it won’t be too much problems if I show to general manager and senior management then the boss will agree with it.”

Moreover, interviewee five stated:

“My manager helps me when I get problems and no matter it is related to work issue, or personal matter.”

Both of hierarchical and supportive style could be found in the company. The decision-making needed to pass from level to level and it needed to fit the company’s rules and regularities. Moreover, not all the employees participate in the process of decision-making. The middle manager played had an impact on how knowledge process was carried out as they were the mediation between the top management and the employees.

The managers were playing the roles as being telling and consulting, they identified the solution of the queries of employees or suggested the most proper approach. Moreover, the managers take responsibility for final outcomes and this is typical Taiwanese culture.

The research findings suggest that middle managers play an important role in stimulating knowledge sharing as they can help to create a culture that facilitates knowledge sharing between employees. They set the example for employees. Moreover, middle managers have a great impact on how organisational processes are carried out as they are the mediation between top management and employees.

Rewards. It refers to what extent employees receive any compensation for good performance or encouragement in knowledge sharing behaviours. Recognition and incentives are two dimensions to look at this aspect.

The classification of reward (recognition or incentives) was influence by reward of the employee’s preference and awareness, and whether the reward promoted or inhabits the employees’ knowledge sharing behaviours.

As interviewee three stated:

“Yes, the company will commend for the outstanding performance and also we will get financial reward when the company reaches the target.”

The reward would be given to the employee who got the good performance, such financial reward once they researched the target, and it was on the basis of the department, some of them got rewards monthly and other got it quarterly.

Moreover, recognition was another way of the reward they received, such as the verbal appreciation in public (formal meeting), or just a simply thanks you (formal meeting), as IT manager stated:

“I would commend the employee who has a great performance during the meeting.”

The employees were more appreciated for incentives in terms of cash bonus instead of verbal appreciation, because of the verbal appreciation may cause other people to be jealous and they couldn’t get along with their colleagues.

Yet, there was no financial reward for knowledge sharing, they only received recognition once the new ideas came out, and this wouldn’t discourage them to share knowledge and experiences, as interviewee three stated:

“The factors why I would feel like to share my knowledge, well, self-fulfill I guess and receiving positive recognition from colleagues”.

Therefore, reward didn’t play a major role in stimulating knowledge sharing. As the results, it took a further perception of motivation, the term intrinsic which refers to personal characteristic.

Lin (2007) identifies the individual factors which influences knowledge sharing, namely, enjoyment in helping others and knowledge self-efficacy. The employees feel pleasure whilst helping their colleagues, because they can learn more things to gain experience and knowledge. People who derive enjoyment from helping others may be more inclined to share knowledge as they are intrinsically motivated to contribute knowledge. Furthermore, another factor that promotes knowledge sharing behaviours is self-fulfillment as the employees receive positive recognition from their colleagues and it is consistent with self-efficacy. Self-efficacy refers to the capabilities to accomplish the task and also help motivate the employees to share knowledge with colleagues (Wasko and Faraj, 2005).

B. Cultural Aspect

The interview questions were designed to be relevant to the literature review which were based on by The GLOBE project (House et al, 2004) which is

identified nine cultural dimensions. However, not each dimension fits into the research objectives.

Goal to Achieve. It refers to goals that are important for employees to accomplish, be it on an individual or team basis.

As it was a small company, the task was usually assigned to individual, however, some parts of task couldn't be done alone and the certain tasks were accomplished through teamwork.

As interviewee one stated:

"Each department needs to collaborate and communicate to reach the task or goal. Without collaboration, no one can execute any single task from design to production."

She further stated:

"To achieve the goal of a group is more important, group success is much longer term... as many of the tasks cannot be done solely."

Goal to achieve is associated with institutional collectivism (House et al., 2004), and Taiwan is one of the countries where many examples of institutional collectivism can be found. The research findings indicate that the employees collaborate with each other to accomplish the goal, on an individual and team basis and it is consistent with people from collectivist cultures work better with team work (Möller and Svahn, 2004).

Embedded in group. It refers to the interactions among employees and managers in terms of the feeling towards their group.

As several participators stated:

"I feel it like as a family".

Moreover, the interactions among the employees and the manager felt like as a family, apart from dealing the job issue, the personal matters and they treated their colleagues as family members instead of seeing them as the competitors.

As most of the participators stated:

"We have time to deal with personal matter and family issues."

Having enough time to deal with personal matter and spending it with family is an essential factor in Taiwanese culture.

Embedded in group is associated with in-group collectivism (House et al., 2004). The research findings highlight how member of company feel like a family and a close group of friends. Hence, this situation appears to be consistent with in-group collectivism.

Manager's Standpoint. It refers to the interactions between employees and managers in terms of using power.

As several participators stated:

"I can't say I have to obey my manager with no doubt but we need to respect their decision and get our tasked be done as expected."

It wasn't really necessary to obey the manager with not doubt as they were at the position to express their feelings and ideas, and when they came across the different opinions, they tried to figure out the best way by communicate with each other.

Moreover, from the point of managers' view,

As design manager stated:

"It is not frequent necessary for me to use authority and power when dealing with my employees."

Manager's attitude is associated with power distance (House et al., 2004). The findings appear to be consistent with power distance this culture dominion (House et al., 2004; Hofstede, 1980, 2001), as not all the employees participate in the process of decision-making. One significant difference is the employees could express their ideas even if it cannot be part of the final decision and this can be seen as typical Taiwanese culture.

Long Term Perspective. It refers to an arrangement of personal development for employees or any further strategies for companies.

As interviewee one stated:

"Yes, but it was more about company strategic, not related to employees." Moreover, the IT manager stated:

"The company doesn't really provide any particularly training course for the personal or career development, due to the budget."

Therefore, the company didn't really have any specific strategy for the personal development of employees, however, the company did encourage the employees to attend the workshop outside of the company. They noticed the need of their employees only if the problems had occurred.

Long term perspective is associated with future orientation culture dimension (House et al., 2004). From the researching findings, it is consistent with this cultural dimension.

Acceptability towards Uncertain Situation. It refers to what extent people accept unsure situations or unfamiliar incidents.

As several participators stated:

"I will try to be calm down whilst dealing with things that I never encountered or ambiguous situation."

And they further addressed:

"I would ask help from my colleague or my manager."

Some of the employee were being panic and it caused their colleagues would notice it, or some of them would be calm down.

Acceptability towards uncertain situations is associated with uncertainty avoidance (House et al., 2004; Hofstede, 1980, 2001). The research findings suggest that whenever the employees encounter any difficulties, they will ask the managers for help immediately. It appears to reflect they are likely to be guided to identify a clear instruction to solve uncertain circumstances. However, the employees carry out autonomous roles and this situation appears to be contrary to uncertainty avoidance (House et al., 2004; Hofstede, 1980, 2001).

Care about the Feelings of Subordinates. It refers to what extent managers care about the feelings and capabilities of employees.

As interviewee three stated:

“He will consider my feeling and ideas, sometimes, when he assigns me the task, he would ask me whether can I handle it or not. If I can't I will inform him or ask for help.”

It seemed like the manager did consider about the employees' feeling and capabilities, when the employees encountered unexpected circumstance.

Care about the feelings is associated with human orientation cultural dimension. According to House et al., (2004) that Taiwan is low score on this dimension and it is contrary to the research finding, in Taiwanese society, people tend to be friendly to each other, within the company, employees and managers help each other with not only the work issues but also the personal matters. Moreover, it is consistent with Chinese manager will pay attention to building and maintaining personal relationship rather than just being a task-orientation (Chen and Partington, 2004).

Social Interaction. It refers to what extent people maintain the relationships between themselves when they encounter different opinions.

Several participators stated:

“We try to maintain harmony within the company and try to avoid the conflict.”

In the case study company, the employees try to avoid the conflict and maintain harmony. When the different opinions arise, they will not really use a strong attitude or insist on their own opinions at that moment. However, they will try to express their own ideas but not to force others to accept it. Hence, it appears to be consistent with Chinese people are likely to place an emphasis on group harmony and maintain relationships with all involved whilst resolving conflicts (Chen and Partington, 2004; Zeng et al., 2009). Moreover, an interesting finding is instead of telling the first person again, they will ask a third party to do it and it is typical Taiwanese culture.

In summary, the research findings suggest that if managers and employees contact with each other frequently, it will make the communication relationship goes both of horizontal level and vertical level. This appears to be consistent with the contact between employees and manager is often close to each other in SMEs. Hence, the knowledge flow goes up and down hierarchical efficiently (Desousa and Awazu, 2006). The middle managers play an important role in stimulating knowledge sharing, as they are being supportive and set the example for employees.

In Taiwan society, it is hard to change people's past behaviours, it may be due to that fact that people are less inclined to change the life of style or things they are used to and this can relate to uncertainty avoidance cultural dimension (House et al., 2004; Hofstede, 1980, 2001). As a result, under this condition that causes managers will need to use powers difference to ensure socially responsible behaviours such as on-going circumstance which still needs to reinforce the perception of employees' behaviours.

Explicit knowledge transforms into tacit knowledge that is easier when people trust each other and willing to contribute their own valuable knowledge. (Swift and Hwang, 2013). Therefore, trust is based on interpersonal interaction among people and they are willing to share knowledge and provide assistance to one another in a crisis.

IV CONCLUSION

To conclude, organisational context and cultural aspects are mediating artifacts that facilitate knowledge sharing behaviours in Taiwanese SMEs.

With regard to cultural aspects, the finding identifies the similarities and differences one of each from the GLOBE project (House et al., 2004) cultural dimensions. Moreover, it indicates the typical Taiwanese culture.

It suggests manager's standpoint, acceptability towards managing uncertain situations and social interactions have the greatest impact on the knowledge sharing behaviours. Since Taiwan is strong power distance (House et al., 2004; Hofstede, 1980, 2001; Chen and Partington, 2004), manager is likely to prefer subordinates to obey a standard set of rules and procedures, employees follow the direction of their manager. However, in the case study company, the managers are also being supportive and caring for the subordinates. Hence, leadership style apparently intends to be both style, this is consistent with Taiwanese way of doing things as Confucian values are influenced in Taiwanese society in terms of maintain harmonious relationships.

Furthermore, from social interaction that indicates trust contributes to successful human behaviours and it

is one of the important cultural factors which leads to the knowledge process.

REFERENCES

- Ardichvili, A., et al. (2006). Cultural Influences on Knowledge Sharing Through Online Communities of Practice. *Journal of Knowledge Management*, 10 (1), 94-107.
- Alvesson, M. (2004). *Knowledge work and knowledge-intensive firms*. OUP Oxford.
- Boer, N.I. (2005). *Knowledge Sharing within Organization: A Situated and Relational Perspective*. Rotterdam: ERIM.
- Boer, N-I. P.J. van Baalen, & K. Kumar. (2002). An Activity Approach for Studying the Situatedness of Knowledge Sharing. *Proceedings of the 35th Annual Hawaii International Conference on System Sciences*, 7-10 January, 1483-1492.
- Charmaz, K. (2006). *Constructing Grounded Theory: A Practical Guide Through Qualitative Analysis*. London: SAGE.
- Crowston, L., S. Sieber & E. Wynn. (2007). *Virtuality and Virtualization*, New York: Springer.
- Chen, P. and Partington, D. 2004. An interpretive comparison of Chinese and Western conceptions of relationships in construction project management work. *International Journal of Project Management* 22(5): 397-406.
- Dalkir, K. (2005). *Knowledge Management in Theory and Practice*. Oxford: Elsevier Butterworth-Heinemann.
- Desouza, Kevin C., and Yukika Awazu. "Knowledge management at SMEs: five peculiarities." *Journal of knowledge management* 10.1 (2006): 32-43.
- Easterby-Smith, M., R. Thorpe & P. R. Jackson. (2012). *Management Research*. 3rd edition, London: SAGE.
- Fan, Y. (2000). A classification of Chinese culture. *Cross Cultural Management: An International Journal*, 7(2), 3-10.
- Fey, C.F. & P., Furu. (2008). Top Management Incentive Compensation and Knowledge Sharing in Multinational Corporations. *Strategic Management Journal*, 29, 1301-1323.
- Fontaine, R. (2007) Cross-Cultural Management: Six Perspectives. *Cross-Cultural Management: An International Journal*, 14(2), 125-135.
- Ford, D.P., & Y.E., Chen. (2003). Knowledge Sharing in a Multi-Cultural Setting: A case Study. *Knowledge Management Research & Practice*, 1, 11-27.
- French, R. (2007). *Cross-Cultural Management in Work Organisations*. London: Chartered Institute of Personnel and Development.
- Gill, J., P. Johnson. (2002). *Research Methods for Managers*, 3rd edition. London: SAGE.
- Hislop, D. (2005). *Knowledge Management in Organisations: A Critical Introduction*. Oxford: Oxford University Press
- Holden, N.J. (2001). Knowledge Management: Raising the Spectre of the Cross-Cultural Dimension. *Knowledge and Process Management*, 8 (3), 155-163.
- Holden, N.J. (2002). *Cross-Cultural Management: A Knowledge Management Perspective*. Harlow: Pearson Education Limited.
- Hofstede, G. 1980. *Culture's consequences: international differences in work-related values*. Newbury Park, CA: Sage.
- Hofstede, G. 1991. *Culture and organizations*. Maidenhead. UK: McGraw Hill.
- House, R.J., et al. (2004). *Culture, Leadership, and Organisations: The GLOBE Study of 62 Societies*. USA: SAGE
- Hsu, I. C. (2006). Enhancing employee tendencies to share knowledge—Case studies of nine companies in Taiwan. *International Journal of Information Management*, 26, 326-338.
- Hsu, W. T., Chen, H. L., & Cheng, C. Y. (2013). Internationalization and firm performance of SMEs: The moderating effects of CEO attributes. *Journal of World Business*, 48(1), 1-12.
- Hsu, R. C., Lawson, D., & Liang, T. P. (2006). Factors affecting knowledge management adoption of Taiwan small and medium-sized enterprises. *International Journal of Management and Enterprise Development*, 4(1), 30-51.
- Hutchings, K., & K., Mohannak. (2007). *Knowledge Management in Developing Economies: A Cross-Cultural and Institutional Approach*. Cheltenham: Edward Elgar Publishing Limited.
- Johnson, P., & J., Duberley. (2002). *Understanding Management Research: An Introduction to Epistemology*. London: SAGE
- Jones, O., et al. (2003). *Conceptualising Business Knowledge in SMEs: Sectoral Recipes and Activity systems*. Egos Colloquim, Stockholm.
- Lee, C.L., C.T. Ho & Y.L. Chin. (2008). The Impact of Knowledge Management Enablers on Non-Financial Performance in small and medium enterprises. *International Journal of Technology Management*, 43(1-3), 266-284.
- Lim, D., & Klobas, J. (2000). Knowledge management in small enterprises. *The electronic library*, 18(6), 420-433.
- Lin, H. F. (2007). Effects of extrinsic and intrinsic motivation on employee knowledge sharing intentions. *Journal of information science*.
- Little, S. & T., Ray. (2002). *Managing Knowledge: An Essential Reader*. 2nd edition, London: SAGE.
- Macpherson, A. (2008.) *Making Sense of Mediated Learning in Small Firms*. OLKC Copenhagen.
- Maseland, R. & A. Hoorn. (2009). Explaining the Negative Correlation between Values and Practices: A note on the Hofstede – GLOBE debate. *Journal of International Business Studies*, 40, 527-532.
- Mead, R. (1998). *International Management*, 2nd edition. Oxford: Blackwell.
- Möller, K., & Svahn, S. (2004). Crossing East-West boundaries: Knowledge sharing in intercultural business networks. *Industrial Marketing Management*, 33(3), 219-228.
- Myers, M.D. (1999). Investigating Information System with Ethnographic Research. *Communications of the AIS*, 2(4), 1.
- Ruiz-Mercader, J., MeroñO-Cerdan, A. L., & Sabater-Sánchez, R. (2006). Information technology and learning: Their relationship and impact on organisational performance in small businesses. *International Journal of Information Management*, 26(1), 16-29.
- Sparrow, J. (2005). Classification of Different Knowledge Management Development Approaches of SMEs. *Knowledge Management Research & Practice*, 2005, 3(3), 136.
- Sparrow, J. (2001). Knowledge Management in Small firms. *Knowledge and Process Management*, 2001, 8 (1), 3.
- Swift PE, Hwang A. (2013). The impact of affective and cognitive trust on knowledge sharing and organizational learning. *Learn Organ* 20:20-37.
- Venaik, S. & P. Brewer. (2008). Contradictions in national culture: Hofstede vs GLOBE', *Academy of International Business 2008 Annual Meeting*. Milan, Italy 30 June-3 Jul.
- Wu, W. H., Ho, C. F., Fu, H. P., & Chang, T. H. (2006). SMES implementing an industry specific erp model using a case study approach. *Journal of the Chinese Institute of Industrial Engineers*, 23(5), 423-434.
- Wong, K.Y. (2005). Critical success factors for implementing knowledge management in small and medium enterprises. *Industrial Management & Data Systems*, 105(3), 261-279.
- Wong, K.Y., & Aspinwall, E. (2005). An empirical study of the important factors for knowledge-management adoption in the SME sector. *Journal of knowledge management*, 9(3), 64-82.
- Yin, R.K. (2008). *Case Study Research: Design and Methods*, 3rd edition. London: SAGE.
- Zhang, X., de Pablos, P.O., & Xu, Q (2014). Culture effects on the knowledge sharing in multi-national virtual classes: A mixed method. *Computers in Human Behavior*, 31, 491-498.
- Zeng, S. X., Xie, X. M., Tam, C. M., Sun, P. M. (2009). Identifying cultural difference in R&D project for performance improvement: a field study. *Journal of Business Economics and Management* 10(1): 61-70.

The Effect of Macro Economy and Characteristics of Company on Beta Syariah Shares

Lisa Kartikasari

Sultan Agung Islamic University (UNISSULA), Indonesia, lisakartika@unissula.ac.id

ABSTRACT

This study investigated the characteristics of company and macro economy those influence beta of syariah shares. The characteristics of company, as the independent variable consists of earning per share, dividend payout ratio, leverage, assets size, current ratio and investment return. Macro economy consists of inflation and currency exchange rate. Sample is collected with purposive sampling method for 4 years of observation in Jakarta Islamic Index. The total samples are 90 companies. The result of study upon the characteristics of company, and macroeconomic variables to the return of syariah shares indicated that only current ratio variable had the level of significant of 5% influencing beta syariah shares.

Keywords: Beta of syariah shares, characteristics of company, macro economy.

I INTRODUCTION

Syariah capital market shows to progress as its index in the Jakarta Islamic Index (JII) increases. As index on JII increases, although the value is not as good as that on the Composite Share Price Index (IHSG), but the increasing percentage of the index on JII is greater than that on JCI. This is because of the properness, blessing, and growth concepts of syariah capital market on which syariah shares are traded. Syariah capital market uses the principles, procedures, assumptions, instrumentation, and applications of Islamic epistemological values.

Islamic Index or Syariah Index has helped institutions to invest their excess of funds in investment complying with syariah. Therefore Islamic Banks, Takaful, and other Islamic financial institutions have an alternative to invest their funds and distribute their profits to the customers.

The trade of some types of securities, both in conventional and Islamic capital market have different rate of returns and risks. High risks and return of shares are related to the condition of characteristics of company, industry and macro-economy (auliyah and hamzah, 2006). The risks of securities are in the form of specific and systematic risks. Specific risk can be eliminated by forming a good portfolio. Systematic risk cannot be eliminated by forming a good portfolio because the risks are

beyond the company. Systematic risk is also referred to beta because it is a measure to systematic risk. Systematic risk can occur because of the characteristics of company, industry, and macro-economic factors. A beta coefficient is used in measuring the risk. Beta of securities is crucial to analyze securities or portfolio. Beta securities indicate the sensitivity level of profit of securities over market changes.

There are only few studies on syariah capital market, particularly in Indonesia conducted by previous researchers. Some studies on syariah capital market were conducted by Waluyadi (2015), Chairiyah (2013), Auliyah and Hamzah (2006) and hamzah (2005). It is interesting to conduct study on syariah capital market to the beta influenced by the variables of the characteristic of company, and macro-economy, because it is the nature of return and risk to always be inherent to any investment, especially stock investment, both common stocks and shares pursuant to syariah.

Based on the background, the problem of this study shall be whether the variable of characteristics of company (earning per share (EPS), dividend payout, leverage, current ratio, asset size and return on investment), macro economy (exchange rate and inflation) shall influence beta of syariah stocks in Indonesian Stock Exchange.

II LITERATURE REVIEW

A. The Relationship between the Characteristics of Company to Beta of Syariah Shares

Earning per share (EPS) is the comparison between net profit after tax in a fiscal year and the number of issued shares (Jogiyanto, 2000). Investors make investment under consideration to get the most possible earning. High EPS reflects the results or income the shareholders will receive for each share they own. Company's high EPS will draw investors' interest to make investment to the company. Increasing demand for shares causes an increase of share price and eventually the return of shares will also increase. As the return of shares increases, the return of market increases, thus the beta of shares will also rise. Earning per share gives a positive influence to the return and beta of syariah shares. Results of the research (Chairiyah, 2013; Ratna &

Priyadi, 2014; Patiku, 2008), finds that earning per share affects the beta of shares.

H₁: Earning per share influences beta syariah shares

Paid is divided by available net income for common shareholders is dividend payout. Litner (1956) provides a rational reason that company is reluctant to lower its dividend. If the company decreases the dividend, it will be considered a bad sign, because it will be deemed in need of fund. High paid dividend and earnings available to shareholders will attract investors to make investment. The price of shares will also increase. An increase in price of shares will be followed by an increase in return of shares. Therefore, dividend payout gives positive influence to the return the shares. An increase in the price of shares because of company's high dividend payout that results in an increase in the return of shares will be followed by an increase in the beta of shares. As the return the shares increase, the return of market will also increase. Beta, as volatility measurement between the return of portfolio shares with the return of market, will also increase. The results of study by hamzah (2005) and Waluyadi (2015) indicate that the dividend payout have positive influence on the beta of syariah shares. Dividend payout influences to the return of shares based on the results of study by Hamzah, (2005).

H₂: Deviden payout influences beta syariah shares

Leverage is the use of a particular property or assets which will result in company's fixed cost. In this case, the fixed cost can be in the form of depreciation costs or interest cost originally from debt bonds, bank loans, etc. This ratio can show how far the company is funded by debt or outside parties with the company's ability represented by the capital (equity). As the company has loans in the form of debt from outside parties, indicates that it is trusted by the lenders. A company that is trusted by outside parties will attract investors to make investment to the company. Thus, the company's price of shares will increase, resulting in an increase in the return and beta of shares. The results of study by Hamzah (2005) indicate that leverage gives positive influence to the beta of syariah shares. Likewise the study by Lisa Kartikasari (2007) that leverage operation influences the beta of shares. Ulupui (2005) in her study finds that leverage influences the return of shares.

H₃: Leverage influences the beta of syariah shares

Asset size is a measurement variable of asset that is measured from the total assets. Asset size is used as a representing measurement for the size of a

company. Watts and Zimmerman (1990) hypothesized that larger companies tend to invest their funds to low-variant projects with lower betas to avoid excessive profit. Investment in low-beta projects with lower the risk on the company. The size of the company has a significant influence in explaining the amount of returns (Sembiring, 2005), if the company has low market capacity has a greater rate of return than higher capacity companies. While study (Hamzah, 2005 and Wayuladi, 2015) concludes that asset size influences positively to the return of shares. Size refers to the amount of return to company within a certain period that derives from company's main activity. Based on description above, we can hypothesize as follows:

H₄: Asset size influences the beta of syariah shares

Current ratio is a measurement of liquidity that is current assets divided by current debt. Liquidity is predicted to have a negative relationship with beta, that it is rationally known that the more liquid the company, the smaller the risk is. Current ratio measures the company's ability to manage its liquid asset in securing short-term debt. Larger current ratio indicates the higher the company in meeting short-term obligations. Obligation to pay a cash dividend, high current ratio shows that investors trust the company's ability to pay the promised dividends (Frianto, 2005). The results of study by Hamzah, (2005) indicated that the current ratio gives positive influence to the beta of shares. Prihantini, (2009) also explains that the regression coefficient of CR is equal to 0.003. The value of positive coefficient indicates that CR gives positive influence to the return of shares. According to the description above, we can hypothesize as follows:

H₅: Current ratio influences beta syariah shares

Return on investment (ROI) is a form of profitability ratios that is intended to measure the company's ability with the overall funds invested in assets to generate profits. Thus this ratio connects the profit obtained from company's operations (net operating income) with the number of investments or assets used to generate profit in the operation (net operating assets). The return on investment of higher company will have an influence on the increase of company's price of shares that will also increase the company's return of shares. The results of study by Trisnaning Sari (2009) explained that return on investment shows positive influence to the return and beta of shares. Hamzah (2005) shows that return on investment gives positive influence to the beta of syariah shares. According to the description above, we can hypothesize as follows:

H₆: Return on investment influences beta Syariah shares

The currency of every nation shall be valued in relation to other currencies through currency exchange. Company's profit shall be considered even more in an unstable condition, because of other predicted information that has higher risks in terms of profit gain. This condition has investors can only take profit as the sole trustable information and surely having happened. The results of studies by Hamzah (2005) and Auliyah and Hamzah (2006) showed that currency exchange influences the beta of syariah shares. Prihantini (2009) in her search finds that currency exchange influences the return of shares. According to the description above, we can hypothesize as follows:

H₇: Currency Exchange Rate influences the beta of syariah shares

Inflation is a tendency of general and continuous increase of prices. Price increase of one or two items shall not be identified as inflation, unless it extends to (or result in increase of) a portion of the price of other goods (Boediono, 1998). Theoretically, shares investment can provide good value (hedge) from the influence of inflation because shares are real asset. Inflation will affect the distribution of income, depending on the cause of inflation, where nominal income where tends to increase rapidly in a period of inflation, so real income can increase or decrease during the inflation (Samualson, 2001). Prihantini (2009) in her study shows that inflation gives negative effect on the return of shares. According to the description above, we can hypothesize as follows:

H₈: Inflation influences the beta of syariah Shares

III RESEARCH METHODOLOGY

A. Population and Sampling Procedures

Population of this study covers all public companies registered in Indonesian Stock Exchange (BEI). This study uses purposive sampling technique. The samples are companies with the following criteria: (1) Issuer's shares are proper pursuant to syariah, that the properness of shares shall be legalized by Syariah Supervisory Body. (2) The shares are registered in *Jakarta Islamic Index*. (3) The companies are among 30 greatest in *Jakarta Islamic Indeks* at least 3 times since January 2010 to December 2013. (4) Issuing company issues annual financial statement since January 2010 to December 2013. The finally collected samples are 90 companies.

B. Variable Identification

In this study, the variables to be investigated shall be the characteristics of company, macro economy, and beta of syariah shares. The independent variables of this study shall be the characteristics of company and macro economy, while the dependent variables shall be beta of syariah shares. The characteristics of company variables to be investigated in this study shall be *earning per share, dividend payout, leverage, current ratio, return on investment* and *asset size*. The macro economy variables to be investigated in this study shall be *currency exchange* and *inflation*.

IV RESULTS OF STUDY AND DISCUSSION

Table 1 shows the results of Regression Test Model.

Table 1. Results of Regression Test Model

Model	t	Sig.
1 (Constant)	.559	.579
EPS	-.810	.422
DTA	.098	.923
CR	-2.010	.049
ROI	-1.270	.209
DPR	.109	.914
Ln.TA	-.145	.885
INFLASI	-.807	.423
KURS	-.105	.917

Dependent Variable: Beta

Earning per share variable does not influence beta of syariah shares. It is because investors, in making investment, are under consideration of obtaining the most possible earning. High earning per share reflects the outcome or income the shareholders will receive for each share they own. Tandelilin, (1997) state that BEI is a developing capital market and every company manages to settle its position, thus the price formed is not determined by only earning. This results support the study by Auliyah and Hamzah (2006). However, the results are not support to that of study by Patiku (2008). But result from Chairiyah (2013) and Ratna & Priyadi (2014) support this study.

The second hypothesis of this study is not proven, that dividend payout ratio does not influence beta of syariah shares. This results support the study by auliyah and hamzah (2006). However, they are different to Hamzah (2005). This difference, besides because of a great number of companies to be the samples do not distribute the dividend, it is also possibly because of different period of study and different term of period.

The third hypothesis of this study is rejected. That leverage does not influence beta of syariah shares. Higher debt to equity ratio shows the composition of total debt (short-term and long-term) is higher compared to the total own capital, thus the company's cost shall be higher to other party (creditor). Increasing cost to creditor shows that the company's capital depends to other party, thus decreasing investors' interest to invest their fund to the company. This results support the study by Auliyah and hamzah (2006) and Ratna & Priyadi (2014) but different with the results of study by Hamzah (2005), Lisa Kartikasari (2007) and Ulupui (2005).

The fourth hypothesis is rejected in this study, where asset size does not influence beta of syariah shares. A company with small market capacity has higher return compared to large capacity company. It is because small market capacity is easy to manage. The results of study by Auliyah et al (2006) and Chairiyah (2013) support this study, but it is contradictory to the study by Hamzah (2005).

Current ratio variable influence beta of syariah shares. This results support the study by hamzah, (2005) indicating that current ratio influences positively to the beta beta of syariah shares. Current ratio is one of measures of liquidity ratio that is calculated by dividing with liquid assets with debt. Higher current ratio shows the higher company completing its short-term obligations. The obligation to pay cash dividend, the higher current ratio shows investors' trust on the company's ability to pay the promised dividend.

Return on investment variable does not influence beta of syariah shares. This results support the study by Auliyah and hamzah (2006) and different with the results of study by Trisnaningsari (2009) and Hamzah (2005).

The examination on the seventh hypothesis of this study is to observe that currency exchange influence beta of syariah shares. This results supported by hamzah (2005) and auliyah and hamzah (2006) that currency exchange influences the beta of syariah shares. But result from Ratna & Priyadi (2014) not support this study. This difference is determined by fluctuation of foreign exchange, where company's profit will get attention more in an unstable condition, because of other predicted information has high risk in profit making.

The results of the eight hypothesis that inflation influences beta of syariah shares are rejected. Inflation will influence the distribution of income, depending on the cause of inflation, where nominal income tends to increase rapidly in inflation period, Lisa Kartikasari. (2007). The Influence of fundamental Variable to the systematic risk of manufacture Company listed in Jakarta Stock

thus real income will increase or decrease during inflation (Samualson, 2001). These results not supported by Ratna & Priyadi (2014) and Prihantini (2009).

V CONCLUSION AND SUGGESTION

The results of study find that, only current ratio variable has influence on beta syariah shares. The companies in Jakarta Islamic Index with high Current Ratio has low beta of shares. Current ratio is one of measure of liquidity ratio, measured by dividing liquid assets with debt. Higher current ratio indicates the higher a company complies with its short-term obligation. Obligation on payment of cash dividend, higher current ration indicates investors' trust upon the company's ability to pay the promised dividend. For future study, it must pay attention to several factors that can increase the validity of study, they are increasing the term of study, thus the probability shall be higher and to consider the use of beta of shares in daily shares.

REFERENCES

- Aruzzi, M. Iqbal, dan Bandi. (2003). The influence of interest Rate, Profitability Ratio, and Beta accounting to Beta of Syariah Stock in Jakarta Stock Exchange. Journal of National Accounting Symposium VI.
- Auliyah Robiatul dan Hamzah Ardi. (2006). The Analysis of Company, Industry, and Macro Economy Characteristics to the Return and Syariah Stock Beta in Jakarta Stock Exchange. Journal of National Accounting Symposium IX Padang.
- Boediono. (1998). Ekonomi Moneter. Yogyakarta: BPFE
- Chairiyah. (2013). The Influence of assets growth, Return on Equity, Asset size, and earning per share on beta stock. Accounting Journal Vol 1 No 2
- Daniati, Ninna dan Suhairi, (2006). The Influence of information contents of cash flow, gross profit, and Company Size to the expected stock Return (Survey on textile and automotive industry listed in Jakarta Stock Exchange). National Accounting Symposium 9 Padang: Page 1-23.
- Elton, Edwin J., and Gruber, Martin J. (1995). Modern Portfolio Theory and Investment Analysis. 5th Ed. John Wiley & Sons.
- Fidiana. (2006). Fundamental Values and its Influence to Beta of Syariah Shares in Jakarta Islamic Equity Index. Vol. 13 No. 1 March of 2009: 38-58.
- Frianto, Pandia et al. (2005). Lembaga Keuangan. Jakarta. Rineka Cipta
- Ghozali, Imam. (2006). The Application of Multivariate Analysis with SPSS, Diponegoro University. Semarang.
- Gudono dan Nurhayati, Nunik. (2001). The Association between Market-Determined and Accounting-Determined Risk Measures: Evidence from Indonesia. Journal of Accounting, management, and Economics research: Vol. 1 No.2, Page: 171-176.
- Hamzah, Ardi. (2005). The Analysis of Macro Economy, Industry, and the Company characteristics to Beta of Syariah Stock. Journal of National Accounting Symposium 8. Solo..
- Jogiyanto. (2000). Theory of Portfolio and the Analysis of Investment. Second Edition. The Faculty of Economics, Yogyakarta.
- Junaldi, Hamdan. (2007). The Analysis of Fundamental Factor and Currency Rate to Telecommunication Stock Return in Jakarta Stock Exchange of 2003-2005. Journal of National Accounting Symposium VII.

- Exchange. *Journal of accounting and management*: Vol 18. No. 1. April of 2007.
- Lintner, John. (1956). Papers and proceeding of the sixty-eighth annual meeting of the American economic association. *The American economic review*. Vol. 46. No. 2
- Nasser Hasibuan Abdul. (2009). The influence of company characteristics and Macro Economy to the return of LQ-45 stock in Jakarta stock exchange. Thesis of post graduate program of USU Medan of 2009.
- Nazwar, Chairul. (2008). The Analysis of Macro Economy variable influence to Syariah Stock Return in Indonesia. *Journal of Territorial Planning and Development*, Vol.4, No.1, August of 2008.
- N. Teli Husniatin. (2008). The influence of Return On equity (ROE), Earning per Share (EPS) and Price Earnings Ratio (PER) to stock return of company in the sector of service (Hotel & Traveler service) Go Public in 2002 – 2006. Under Graduate thesis, Widyatama University.
- Patiku, Mentari Putri. (2008). The Influence of Fundamental factors to Beta stock. Undergraduate Thesis. Hasanudin University.
- Prihantini, Ratna. (2009). The Analysis of Currency exchange rate inflation, ROA, DER, and CR to stock Return. Thesis of Magister Management study program of Undip of 2009.
- Ratna, Anggi Mashita. (2014). The influence of fundamental factors and economics macro on beta syariah shares. *Jurnal ilmu dan riset akuntansi*: Vol. 3. No. 7
- Samuelson, Paul dan William D. Nordhaus. (2001). *Macroeconomics*. Seventeenth Edition. McGraw-Hill Higher Education
- Sari, P.T. (2009). The Analysis of company, Industry dan Macro Economy Characteristics to the Return dan Beta of Syariah Shares in Jakarta Stock Exchange. Final Project of Economics faculty of Unissula. Semarang.
- Sembiring, Eddy Rismanda. (2005). Characteristics of the company and disclosure of liability social responsibility: Empirical study in Jakarta Stock Exchange. *Accounting National Symposium VIII*. Solo
- Setiawan, Doddy. (2004). Analysis of Fundamental Factor influencing the Systematic Risk before and during Monetary Crisis. *Journal of Indonesia Economics and Business*; Vol. 19, No.3, page: 224-237.
- Sri Artatik. (2007). The Influence of Earning Per Share (EPS) and Price Earnings Ratio (PER) to the Stock Return at the Company of Manufacture in Jakarta Stock Exchange. Under Graduates thesis, Universitas Negeri Semarang.
- Suherman. (2003). The Analysis of Financial Variable influences to the systematic risks in Jakarta Stock Exchange. *Journal of Economics of STEI* No.3.
- Suryana, Bambang Ongki. (2006). The influence of Market, Size, and Book Market Ratio to the stock Return in Indonesia. *Company Financial Sector and Investment in the Period of Juli 1994-June 2005*. *Journal of SNA*.
- Tandelilin, Eduardus. (1997). Determinants of Systematic Risk: The Experience of Some Indonesia Common Stock. *Kelola*; No. 16/IV, p. 101-114.
- Taringan, D.S. (2009). The influence of Inflation Level, Interest rate, and currency exchange to banking company stock prices listed in Indonesia stock exchange. Final Project of Economics Faculty of University of North Sumatera
- Ulpui, I G. K.A. (2005). The Analysis of Liquidity Ratio, Leverage, Activities, and Profitability Influences to Stock Return (The study of Food and Beverage Company categorized as products for consumption in Jakarta Stock Exchange). Udayana University. Denpasar, Bali. *Journal of National Accounting Symposium V*.
- Utami, M and Rahayu, M. (2003). The role of profitability, interest rate, inflation and exchange of value to influence the capital market of Indonesia during economic crisis. *Journal of economic and management*. Vol. 5
- Watts, R., and Zimmerman, J. (1990). Positive accounting theory: a ten year perspective. *The accounting review* 65
- Wayuladi, Toto. (2015). The Analysis of Beta syariah Share (Study in The Jakarta Islamic Index 2010 – 2015). Thesis of Magister Management study program of Mercuru Buana University.

iHOME : An Ambient Intelligence Mobile CrowdSensing Smart Home System

Lim Poon Koon, and Manmeet Mahinderjit Singh

University Sains Malaysia, Malaysia, limpoonkoon@gmail.com; manmeet@usm.my

ABSTRACT

iHOME is a monitoring system that aims to help caregivers take care of their elderly. The main module of the HOPE system provides an intelligent ambient environment by employing prediction based on elderly's daily activity monitor. The goal of iHOME is for non-invasively monitor the elderly behavior pattern and to notify the caregiver upon abnormality detection such as fall detection in the their movement pattern. This enhances the safety of the elderly so that he/she could live independently. The technology behind this includes Arduino-based ambient sensors, tracking based sensors, Case-Based Reasoning prediction algorithm and Pebble wearable application.

Keywords: RFID, Arduino, fall detection, case-based reasoning prediction, smart homes, smartwatch

I. INTRODUCTION

Apart from Malaysia, the world is also ageing rapidly, as we see, population ageing is a long term trend which began several decades ago. People aged 60 and older make up over 11 percent of the global population, and by 2050, that number will rise to about 22 percent. Globally, 40 percent of older persons aged 60 aged 60 years or over live independently, that is to say, alone or with their spouse only (United Nation, 2013). Current systems that introduce by industries provide many types of care services but issues in term of its operational and efficiency still exist.

When an elderly person still has the physical and mental capacity to live independently, but wants companionship with others who are their age, independent living could be a good option. On the other hand, they still need to add the luxury of services and amenities that independent living provides for maintain their independence. Therefore, industries have already targeted on this aspect and present numbers of a system to fulfill the elderly's requirement.

Besides that, in the evolution of embedded Internet or Internet of Thing (IoT), besides of the embedded sensors with other component, it also consumer centric mobile sensing and computing devices such as smartphone mobile devices. Mobile devices will auto consuming the sensor data contribute by the number

of sensors whereas opportunistic sensing is more autonomous and user involvement is minimal (Ganti et.al, 2011). In this project, we are going to achieve Mobile Crowd Sensing by utilizing various ambient sensors and mobile devices. This work is an extension of the existing system known as AMISHA (Lim et.al, 2015).

The aim of this paper is to provide a non-invasive protection with real-time monitoring system for elderly. The focus is on emphasizing how the combination of multiple sensors improves the locate elderly without boundary. Besides that, by utilizing ambient sensors such as motion sensor and weight sensor and placing them correctly into the elderly's environment, the system is able to analyze the daily activity pattern of the elderly and it can inform the caregiver upon abnormality detection such as a missed event or fall. Using the same prediction feature, the system can also intelligently control the home appliances. The objectives of HOPE system-To provide a non-invasive monitoring of elderly behavior pattern and robust notification engine which react upon abnormality detection for enhancing safety and independent living. This paper is organized as follows. Section II reviews related study of existing works of research or industries' field. Section III describes the system implementation of system and introduce the predictive and the fall detection algorithm and hardware implementation of this project. Section IV contains discussion of the system. Finally, section VI contains the conclusion and draws some guideline for the future works.

II. BACKGROUND STUDY OF PROTOTYPE

Based on the requirement of the project, study of related technologies has been done. The study can divide into two sections:

- i. Smart Home, Ambient Intelligent and Prediction
- ii. Fall detection Algorithm & Design

A. Smart Home, Ambient Intelligent and Prediction

i) Smart Home

Researchers around the world have been focusing on the development of the smart home that could potentially assist the daily activities of people. As early as 2002, one of the idea and product discussed in (Das et.al, 2002), the MavHome is a smart home that

uses prediction algorithms to predict and thus automate those activities. In the paper, an example is given that the smart home is able to warm the heater prior to the waking up of user and ready the coffee maker once the user wakes up. This particular smart home uses four layers of agent architecture. The first layer is the physical layer which consists of the sensors, actuators, networks and agents. This is the layer of physical hardware within the house. The second layer is the communication layer where operations such as formatting and routing data done by software to different agents for different needs. The third layer is the information layer that gathers, stores and generates knowledge useful for decision making. Lastly, the decision layer selects actions to execute upon receiving information from other agents.

Besides its architecture, the specialty of MavHome is the three algorithms used for it to accomplish the prediction and automation. The first algorithm is LeZi-update. It is an approach to the location management problem which uses movement histories to learn likely future locations. The second one is SHIP (Smart Home Inhabitant Prediction). The algorithm uses sequence matching with inexact allowances and decay factors to determine the most likely next inhabitant interaction with the home. Instead of automating all the activities, MavHome uses Episode Discovery (ED) to determine which episodes (activities) in an inhabitant are significant and automates them.

ii) Ambient Intelligence

Ambient intelligence (Cook et.al, 2009) is an emerging discipline that brings intelligence to our everyday environments and makes those environments sensitive to us. Ambient intelligence (AmI) research builds upon advances in sensors and sensor networks, pervasive computing, and artificial intelligence. There are five major contributing technologies to AmI: sense, reason, act, secure and HCI. Since AmI is designed for real-world, physical environments, effective use of sensors is important. Some examples of sensors used are strained and pressure sensors on floors, sound sensor for security and speech recognition, image sensor for contextual understanding. To further categorize them, the wired sensors are often cheaper, more robust and use power sources while wireless sensors are more expensive, without wiring and relies on batteries. Another important aspect of AmI is reasoning, without proper model and algorithm to make reason of the collected sensor data, the data are useless. There are different activities to be recognized for different environments. For instance, lifestyle pattern recognition is more suitable in smart home while medicine intake pattern analyzing should be designed for hospital usage. Very

often these pattern recognitions are highly related to spatial and temporal reasoning, very little can be done within an AmI system without an explicit or implicit reference to where and when the meaningful events occurred. For a system to make sensible decisions, it has to be aware of where the users are and have been during some period of time. Apart from the reasoning, HCI (Human-computer interaction) is another big field in AmI as many believe that it should be made easier to live with. While AmI offers great benefits to users by customizing their environments and unobtrusively meeting their needs, privacy and security challenges still exist. The current applications of AmI include smart homes, health monitoring and assistance, hospitals, transportation, emergency services, education, and workplaces.

iii) Human Movement Prediction

In the paper of Akhlaghinia et.al (2007), a few soft computing prediction techniques in ambient intelligence are discussed. One of the major technique is Case-Based Reasoning (CBR). As discussed in the paper, CBR relies on the analysis of data of the sensors to determine the best case to represent the daily activities undergone by the monitored person. The components of CBR consist of case representation, case retrieval, case reuse, case adaptation, case storage and the case base. Case representation will use the sensor data to generate a case based on it and the case retrieval will match the generated case using cases from the case base. User actions will influence the case adaptation process and case storage will store the adapted case. One example of this will be assuming a person goes to a lounge in a predictive building at 7pm and sets his or her favorite light intensity and temperature. In this case, the system will generate a new case in the database for the situation. When the same person goes to this location at the same time in the future, the favorite light intensity and temperature will be set automatically by the system as an existing case in the database matches this situation.

B. Fall detection Algorithm & Design

Cao et.al (2012) designed an Android-based smartphone fall detection application is able to detect a fall event with high efficiency. In the work , the hardware used is a HTC G8. It is a smartphone that is equipped with MSM7225 ARM CPU and most important a tri-axis accelerometer that is used for the fall detection. For the software of this system, Android 2.2 Platform is used and the application written is based on Java and runs on the Dalvik virtual machine.

The equation used in the smartphone application is a threshold algorithm which is more classical in fall

detection. However, the algorithm is made to be able to dynamically adjust its threshold value and time window according to user information such as the ratio of height and weight, sex and age. The algorithm is tested with real data of 400 falls and 1200 ADLs and hence the sensitivity of the algorithm is calculated to be 92.75%. The sensitivity of the adaptive algorithm is higher than the classical algorithm by 6%. The method is proven to be very useful and accurate. However, the smartphone needs to be attached to the waist of the user. It may not be the case in a home environment where users are not usually carrying their smartphones around in the home. Cheffena (2015) research present a system using Smartphone to detect fall. In the study, audio features such as spectrogram, Mel frequency Cepstral coefficients (MFCCs), linear predictive coding (LPC) and matching pursuit (MP) are considered. Besides, four different machine learning classifiers are considered for distinguishing between fall and no-fall events based on the extracted audio features. The classifiers are k-Nearest Neighbor Classifier (k-NN), Support Vector Machine (SVM), The Least Squares Method (LSM) and Artificial Neural Network (ANN). The classifiers are implemented in MATLAB environment.

A 10-fold cross validation is employed to carry out the experiment and analysis. 10 partitions of 26 sound events each are used with 1 of them being the test/validation data and 9 others being training data for the classifiers. The final result shows that best performance is achieved using spectrogram features with ANN classifier with sensitivity, specificity and accuracy all above 98%. The classifier also has an acceptable computational requirement for training and testing. However, there are some limitations with the system. For instance, the young volunteers are used in the experiment, the fall characteristics may not be totally similar to the actual falls by the elderly. Besides, the maximum distance of the subject to the smartphone is limited (around 5 meters) and the system may not work when the person is in a different room.

III. HOME CARE AND POSITIONING SYSTEM FOR ELDERLY (HOPE) IMPLEMENTATION

This section will present the implementation of HOPE.

A. Architecture of iHOME System

Figure 1 shows the overall system architecture design. Basically, the system divides into 4 parts which are users, indoor, outdoor and server.

i) User

The caregiver and admin can access the web application through the computer, whereas caregiver

and elderly are accessing mobile applications through Windows Phone devices. Besides that, elderly required to wear a Pebble smart watch and attached RFID wearable tag with an unique ID. The fall detection algorithm is implemented in the Pebble smart watch.

ii) Indoor

The active RFID readers are located at indoor coverage, which responding to elderly's wearable for indoor tracking purpose. The Arduino-based ambient sensors include different kind of sensors and are placed at different locations for different purposes. For example, motion sensors placed at each location are used to determine the presence of elderly while weight sensors placed on the bed or sofa determine if the elderly is using the particular furniture. All of these ambient sensors transmit data to the Arduino-based parent node in which the node will propagate the data to the web server via Internet connection. Raspberry Pi is configured to simulate different home appliances. It allows real-time changes made to the home appliances' settings to be reflected immediately as the Pi constantly fetch the settings from the web server.

iii) iHOME Server

The web server will host a bunch of RESTful Web services that responding to web and mobile application.

The prediction service and notification service are also hosted in the server. A scheduler is used to run the prediction algorithm daily to update the adapted cases to the latest.

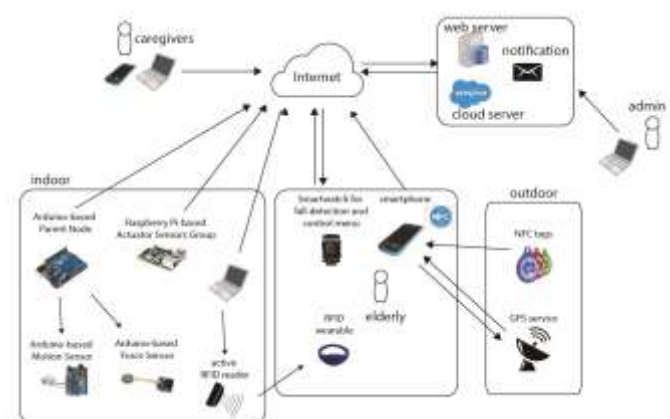

Figure 1. Overall iHOME system architecture

B. Use Case of the system

Figure 3 shows that use case diagram of HOPE system. From the diagram, there are 4 actors of the system which are caregiver, elderly, admin and biometric cloud server. Each actor will describe detail as follows:

i) The caregiver is able to:

- Monitor indoor real-time position

- Send/receive notification
- Trace featured location of elderly visited
- Navigate to elderly current/latest position
- Set elderly's home location
- Receive help message
- Authenticate access mobile application
- Configure elderly's biodata
- Manage user (elderly)

ii) Elderly is able to:

- Wearable update preferences
- Control home appliances
- Being track position
- Navigate to the home
- Call for help to caregiver
- Authenticate access mobile application

iii) The administrator can:

- Do tasks as a caregiver
- Troubleshooting system
- Activate the wearable application
- Sensors pre-configuration & setup
- Setup automation for notification
- Monitor server condition

C. Hardware implementation of the system

i) Arduino-based Ambient Sensors

Arduino boards are used along with different sensors and transceiver to develop the ambient sensors. The framework used in the development process is MySensors libraries. Figure 2-3 shows two different implementations. All the nodes communicate through the transceivers.

Parent Node:

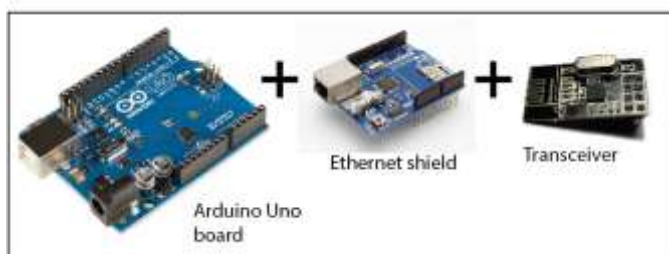

Figure 2. Arduino-board (Parent Node)

The parent node consists of an Arduino Uno board, an Ethernet Shield and a transceiver.

Child Node (Motion):

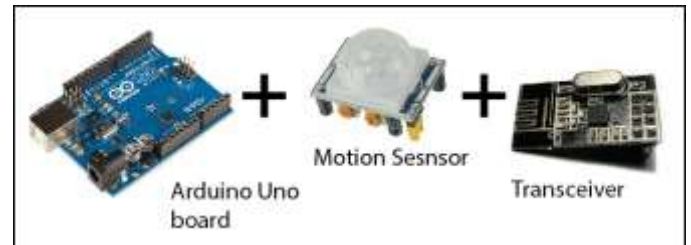

Figure 3. Arduino-board (Child Node) with Motion Sensor

The child node (motion) consists of an Arduino Uno board, a motion sensor and a transceiver.

ii) Raspberry Pi-based TV

Raspberry Pi board is used along with basic color LEDs (red, blue and green) and transistors to simulate the status of home appliances, TV, in this case.

iii) Active 2.4 G RFID reader

Active RFID reader is used to locate elderly at each zone of indoor coverage for position elderly by using wearable RFID tags.

D. Algorithm implementation of the system

i) Fall Detection Algorithm

For prediction algorithm implementation, algorithm in Cheffena (2015) is used. The basic steps involved in the calculation are divided into two: pre-processing of BMI data and accelerometer data analysis. For the preprocessing step, Threshold max ($T_{h_{max}}$) and Window trim (T_{win}) are calculated based on the age, sex and BMI of the elderly. These values are stored and are sent to Pebble smart watch. For the accelerometer data analysis, it is done on the smart watch. Firstly, the resultant acceleration A_{sum} is obtained from the following equation:

$$A_{sum} = \sqrt{A_x^2 + A_y^2 + A_z^2}$$

The resultant acceleration signal is partitioned using the T_{win} and for each segment, A_{max} and A_{min} are captured. The fall is determined if $A_{max} > T_{h_{max}}$ and $A_{min} < T_{h_{min}}$ and $T_{min} < T_{max}$ and signal will be sent from Pebble to the web server immediately.

ii) Prediction Algorithm (Case-Based Reasoning, CBR)

For the prediction algorithm to work, CBR as discussed in Cao et.al (2012) is implemented. The algorithm has been modified to suit the processing need and data available in the system. The algorithm will go through several steps as listed at below to come out with the daily activities schedule (adapted case) of the elderly:

- Retrieve sensor data for latest three days and store them into three different lists

- For each list, partition the sensor data according to location and time and extract the sensors involved in each segment
- For each segment, look for, best suited case from the case base, determine the start time and the time of the case and search for actuator data to get the last settings of home appliances involved. Adapted case is generated for each segment
- Combine the adapted cases from all three days into one single schedule

E. Case study of HOPE Based on Various Scenarios

i) Scenario of elderly moving from one location to another

In this scenario, the elderly will move from bedroom to living room. He or she has just woken up from a nap and would like to watch TV in the living room. Upon reaching the living room, the motion sensor in the living room is triggered. The system will determine if the trigger is fresh (firstly triggered) and will automatically turn off appliances such as light and fan in the bedroom. At the same time, the light and fan in the living room will be turned on with the favorite settings analyzed by the prediction algorithm. When the elderly proceeds to sit on the sofa, the weight sensor on the sofa will be triggered, as set using the automation feature, the activity will switch on the TV along with his or her favorite channel. Figure 4-10 illustrates the notification samples, mobile and wearable user interface for home.

ii) Scenario of elderly abnormal behavior at indoor
The abnormal behaviors of elderly include fuel or missed activity. If the Pebble smart watch detects if elderly has fallen down, signal will be sent to the web server. The web server will send notifications such as SMS or email to the caregiver as configured.

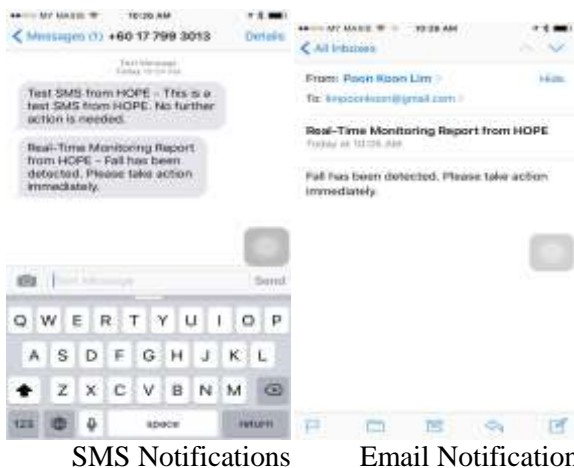

Figure 4 – 5. Sample notifications from HOPE

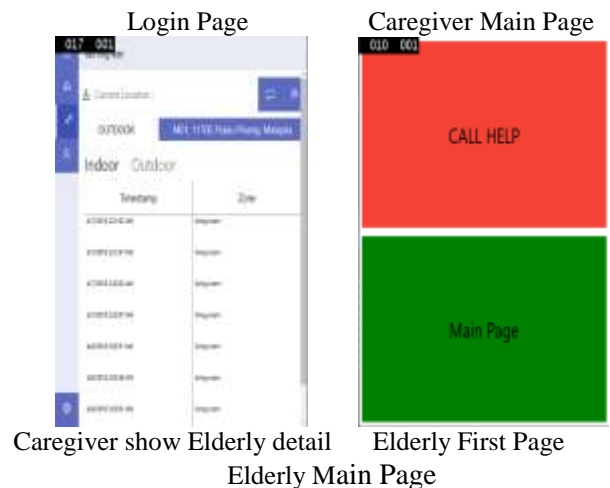

Figure 6 – 7. User interface of iHOME mobile application

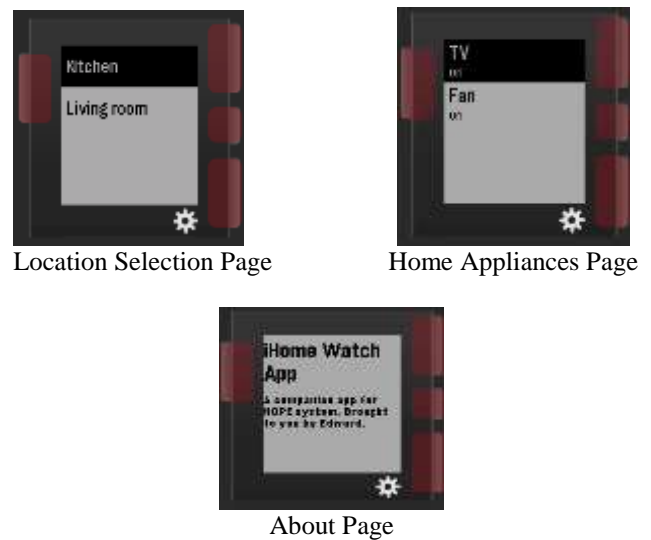

Figure 8 – 10. User interface of iHOME wearable app

IV. SYSTEM DISCUSSION

The system will benefit to the caregiver and elderly by providing the better and caring home environment without caregiver putting full of attentions on elderly. It provides the non- invasive protection of elderly without limiting his/her freedom. In control of the indoor environment by elderly, provide elderly comfort condition. By detecting abnormal behavior of the elderly can enhance the safety of elderly and prevent elderly falls in a dangerous situation. Besides that, the fall detection of smartwatch can acknowledge by caregiver immediately and allow the caregiver react in time.

However, system provided the monitoring and tracking platform for elderly for the caregiver, but the limitation of this system still exists:

A. Mobile Phone

For outdoor coverage, GPS and network access are required to track elderly position and exchange data to cloud server. But there are some places is not coverage of internet and GPS. Therefore, an assumption made is that the mobile phone is always connected to network, no matter is mobile data service or public Wi-Fi. Besides that, the alternative of outdoor tracking service, NFC tags that contain geolocation data assuming deployed around the home region or the city by assuming the smart city concept achieved. Mobile devices using the GPS and mobile service data is high consume battery life of the device which will limit elderly movement at outdoor. Therefore, the system cannot ensure that elderly be tracking and monitoring in 24/7.

B. Ambient Sensors

Despite the ability of ambient sensors to detect the environment, they cannot differentiate if there is more than one person at the location. For example, motion sensor in the living room can only detect the presence of people, but they cannot determine the exact person in the room.

C. Pebble Smart Watch

To make sure the fall detection work, the watch app needs to be activated 24/7. This limits the ability of the elderly to use other watch apps as he or she will need to switch the running app back to the HOPE watch app in order to let the fall detection works correctly. Besides, the Pebble smart watch relies on mobile device to send data to the web server. Hence the overall cost of implementation has increased, but since there are high possibilities that elderly will have at least a smartphone with them, the impact is reduced.

time. This project definitely can provide the bigger convenient to caregiver and elderly as well. As part of the future plan, there are a couple of ways to improve this system:

- Replace smartwatch that consist fitness, medical check sensors to monitor the heartbeat of elderly as a medical alert device
- Include a specialized GUI to let caregiver create custom automations to suit each adapted case from the prediction algorithm according to his or her preferences
- Create a wearable device that has all the functionalities needed for the system because it is more convenient to bring a single device around in the house especially wearable

REFERENCES

- Akhlaghinia.M.J, Lotfi.A, Langensiepen.C, "Soft Computing Techniques in Ambient Intelligence Environments," IEEE, 2007.
- Cao.Y, Yang.Y, Liu.W, "E-FallID: A Fall Detection System Using Android-Based Smartphone," 9th International Conference on Fuzzy Systems and Knowledge Discovery (FSKD 2012), 2012.
- Cheffena.M, "Fall Detection using Smartphone Audio Features," 2015.
- Cook D.J, Augusto J.C, Jakkula V.R, "Ambient intelligence: Technologies, applications, and opportunities," 2009.
- Chaudhary.S, Nath.R, "A Multimodal Biometric Recognition System Based on Fusion of Palmprint, Fingerprint and Face", 2009 International Conference on Advances in Recent Technologies in Communication and Computing.
- Das S.K, Cook D.J, Bhattacharya.A, Edwin O. Heierman III, Tze-Yun Lin, "The Role of Prediction Algorithms in the MavHome Smart Home Architecture," IEEE Wireless Communications, December 2002.
- Ganti R.K, Ye.F and Lei.H , "Mobile crowdsensing: current state and future challenges," in IEEE Communications Magazine, vol. 49, no. 11, pp. 32-39, November 2011.
- Lim.J; Mahinderjit Singh.M; Ahamad Malim.N ; Ambient Intelligence Smart Home Automation (AMISHA) System , i4CT Kota Kinabalu (to be published)
- United Nations Department of Economic and Social Affairs | Population Division, "World Population Ageing 2013", 2013.

V. CONCLUSION & FUTURE WORK

As a conclusion, this system is able help elderly live independently by monitoring and tacking elderly real-

A Secure Near Field Communication (NFC)-enabled Attendance on Android Mobile for Higher Education

David Ong Da Wei, and Manmeet Mahinderjit Singh

Universiti Sains Malaysia, Malaysi, dodwei.dev@gmail.com; manmeet@usm.my

ABSTRACT

Today, many universities evaluate the performance of students in a semester based on the student's attendance to class to make sure that they do not miss out any important class. This lead to taking attendance system is an important issue in universities. In this work, a sensor based attendance system is proposed. This approach adopts sensing technology, which is Near Field Communication (NFC). Besides that, this system also includes face detection and recognition function to identify the person that taking attendance is currently being the owner of the NFC tag. This multi-factor identification system will be designed to cater the limitation of the conventional attendance system. The final results demonstrate that the proposed system thwart against replaying events leading to duplications recording and cheating by legitimate and illegitimate users have due to the added randomization effect in generating sessions for each event recorded within the web-service database. The overall system provides an efficient, accurate and portability solution and work well for the real-life attendance environment within the university.

Keywords: Attendance system, near field communication, cloud-based face detection and recognition

I INTRODUCTION

Successful schools begin by engaging students and making sure that they will come to school regularly, so the attendance rate becomes very important. The attendance rate will be calculated based to the average percentage of students attending school in every class of the course. The attendance rate is important because students are more likely to succeed in academics when they attend class consistently. It's difficult for the lecturer and the class to build their skills and progress if a large number of students are frequently absent. Moreover, the students have given the right to have their own time management at university. This will cause the attendance rate of the class become a major problem because some student may choose to absent from the class. Therefore, students from university in Malaysia are required to attend the class not less than

80% per semester, otherwise a student will be barred from taking any examinations.

The main aim of this paper is to present a sensor-based attendance system designed for recording university students attendance. The objectives of this proposed prototype are : i) to provide a secure student's attendance capturing and tracking processes by enhancing NFC sensor primitive commands and ii) to increase the efficiency and effectiveness of taking student's attendance procedure by using multi-factor authentications concept. In ensuring high accuracy, identification and verification, biometric features such as face identifier has been added together. By adding dual-factor authentication factors; the overall security is enhanced. In this paper, the implementation and architecture of a proposed attendance system known as Multi-factor Identification Authentication System (MIDAS) are presented. The outline of the paper is as follows. Section II focuses on the background studies. Section III provides comprehensive information on the methodology of the system. Nest, section IV and section V present the implementations and the evaluations of the system. Finally, section VI presents the discussion and followed by the conclusion an future work in section VII.

II BACKGROUND STUDY

There have some researches that develop technology-based attendance system. Basically technology-based attendance system can divide into two groups:

- Biometric-based Attendance System
- Sensor-based Attendance System

A. Biometric-based Attendance System

Biometric-based attendance system recognize a person's identity based on the biological characteristic such as fingerprint, hand geometry, voice, retina, iris and face recognition, which reliably distinguishes one person from another or used to recognize the identity. They have five subsystems: data collection, signal process, matcher, storage and transmission. However, the biometric system is suitable for highly secured system and mostly the biometric system is expensive (Meng and Mahinderjit Singh, 2015). Kadry and Smaili (2007) implement an attendance system based on iris recognition. The system takes attendance as follows:

A digital image of one person's eyes to be verified is captured. A feature extracting algorithm is carried out. Minutiae are extracted and stored as a template for verifying later. People to be verified place his eye on the iris recognition sensor. A matching algorithm is applied to match minutiae. Talaviya et.al (2013), implement a system that takes attendance of student by using fingerprint sensor module. When the student enrolls his/her finger on the finger print sensor module, his/her fingerprint will be matched with database to mark the attendance. Chintalapati and Raghunadh (2013), implement an automated attendance management system based on face detection and recognition algorithm. Every time the student enters the class, his / her images will be captured by the camera placed in the entrance. The images will retrieve the identity of the student and take attendance for that student. They use Viola-Jones algorithm for the face detection part. There are five performance evaluation conditions used by them for the face recognition part, which are PCA + Distance Classifier, LDA + Distance Classifier, PCA + SVM, PCA + Bayes, LBPH + Distance Classifier.

B. Sensor-based Attendance System

Sensor based attendance systems are becoming popular nowadays. Barcode technology is a method of identification, which is used to retrieve information in a shape of symbol generally in bar, vertical, space, square and dots which have different widths with each other. A reader or scanner is required to identify the data that is represented by each barcode by using a light beam and scan directly to the barcode. Smart cards can be used as individual identification, building access and network access are part of a multi-tiered program that is in the final stages of rolling out.

Meng and Mahinderjit Singh (2015), implement an attendance system that takes attendance by using RFID. RFID can be categorized into three categories, which are low frequency (LF) RFID, high frequency (HF) RFID, and ultra-high (UHF) RFID. LF has 120-150 kHz, HF has 13.56 MHz, and UHF has 433 MHz. RFID is an automatic identification method, whereby identification data are stored in electronic devices, called RFID tags (Transponders), and RFID readers (interrogators) retrieve these data. Students only need to place their RFID tags which contain a unique ID number on the reader and their attendance will be taken immediately. Every time the student enters / leaves the class, they need to scan their RFID tags with the RFID reader. The RFID reader will read the identification code in the RFID tags and transfer the code to the PC, which is connected with USB. A program in the PC will retrieve the student's identity from the database using the identification code that is received and take attendance for that student.

Figure 1 shows the system architecture of the RFID attendance system.

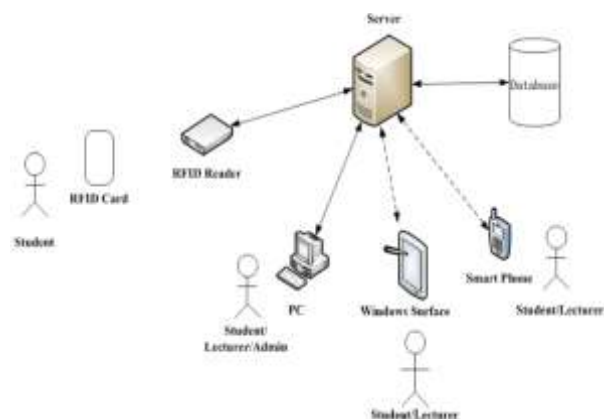

Figure 1. System Architecture for RFID attendance system (Ayu and Ahmad, 2014)

Ayu and Ahmad (2014), implement an NFC-supported attendance system in a University Environment named as TouchIn. Before the class starts, the lecturer will run a mobile application on his/her own NFC-enabled smartphone, and the student that wants to take attendance will run another mobile application which will fetch the student ID from a file, read the device ID and beam (send) it to the lecturer's device by simply touching the device. The attendance of the student will be taken.

III NFC-ENABLED ATTENDANCE SYSTEM

Figure 2 shows the system architecture of the Multifactor Identification System (MIDAS). The system consists of client applications (web application and mobile application) that will be used by the users of the system. The web application will serve as the main platform to be used by any of the system, whereas students and lecturers use the mobile application to view the class attendance information or status. The mobile application also has an additional feature for the student when taking attendance for the class. The web services will act as a medium agent between the view layer (Web application and mobile application) and the data layer (Database).

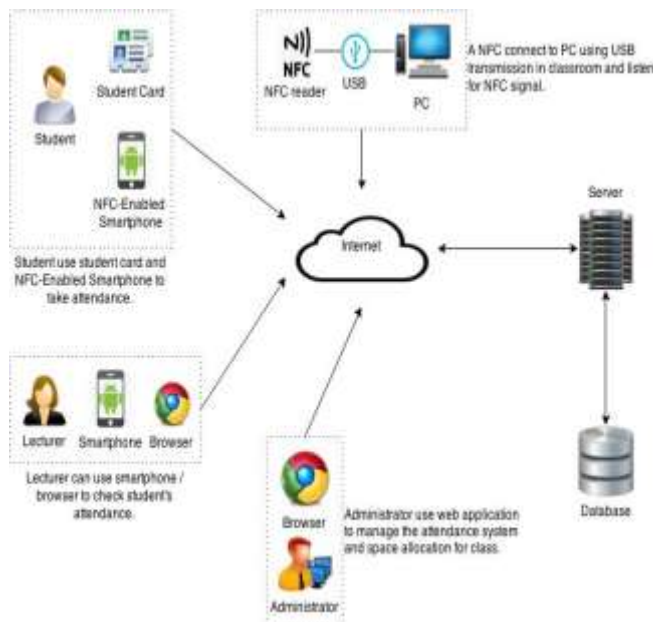

Figure 2. System Architecture Diagram for MIDAS.

A. MIDAS modules

The system consists of four different modules, which are web application, mobile application, Restful Web Services, and Windows Application integrate with NFC. The user of this system divided into three groups, which are:

i) Administrator

An administrator is a user who has the highest privileges and authorization. An administrator can enroll a new student and lecturer, create a class for course in specific academic year, semester, date and time, register course for student and lecturer and user management for the system.

ii) Lecturer

A lecturer is a user who has enrolled by administrator. The lecturer can create a class for course in a specific academic year, semester, date and time, check the class attendance's statistic, check the students' attendance and movement.

iii) Student

A user is a student who has lowest privileges and authorization. The student can check his attendance and movement for a particular class only.

Web Application is to be used by the administrator, lecturer and student. It have five main functions, which are:

- i) Login/Logoff Function
- ii) Registration
- iii) Class Management
- iv) Course Registration Management
- v) Class Attendance & Movement Mangement

A web service contains a set of methods or functions that made visible and accessible on the server in order to be called or invoked by mobile application. Currently, the web services are implemented using Microsoft's ASP.NET Web API, deployed using Windows's Internet Information Service (IIS). The web services are coded in C#. The web protocol used to communicate and access to ASP.NET web services is REST (Representational State Transfer). REST is an architectural pattern that creating an API by uses HTTP as its underlying communication method. The mobile device is connected to the internet uses HTTP. HTTP is a request and response system. The client (Browser, Mobile) sends a request to the endpoint, which is web services and the endpoint, will reply to the client. The window application plays an important role in the system. It is responsibilities for:

i) Check the NFC card is authorized or not.

If the student failed to authorize the NFC card and take attendance by using the unauthorized NFC card, the system will not allow the student take attendance and alert him for authorized the NFC card. However, if the student takes attendance by using the authorized NFC card, the system will allow the student to take attendance and record the student's attendance and movement in the database.

ii) Take student attendance when student scanned the NFC card.

The application has the logic implemented inside and it is able to identify the following condition:

- The student is the first time enters the class.
- The student is out from the class in the middle of class.
- The student enters the class after the student out from the class.
- The student leaves the class after the class is ended.

iii) Classify the student attendance status

Calculate the total time of the student stay in the class. The application has the logic implemented inside and it is able to identify the different scenario, such as Attend, Attend & Incomplete, Incomplete and Absent.

Figure 3 shows some user interface of application and NFC reader/tag that used for this project.



Figure 3. NFC Reader and Tag

Mobile application is to be used by the lecturer and student. The student uses the mobile application for takes and check attendance. The lecturer uses it to view the class statistics and student attendance.

B. Case-scenario of NFC-Attendance System

There are four case scenarios will be discussed in this section whereby the student using the system to sign attendance. In these four cases, three assumptions will be made below.

- If the student scans the card when he/she enters in class time, the system will recognize the student as entering the classroom.
- If the student scans the card in leave class time, the system will recognize the student as leaving the classroom.
- Besides all the assumptions above, the system will recognize the student as out from class or enter class by checking the last movement of the student. If the student scan the card and the last movement of the student is enter class, then the system will recognize the student move out from the class. If the student scan the card and last movement of the student is out from the class, then the system will recognize the student move in to the class. The total duration of time the student leave the class will be calculated based on the time differences between the times move in to the class and last movement, which is the time move out from the class.
- Total time of the student stay in the class should be 80% of the total class time.

Case 1: Student's attendance status is "attend"

If the total time of the student stay in the class is more than 80% of the actual class time, the system will recognize the student as attend to the class.

Case 2: Student's attendance status is "attend & incomplete"

If the total time of the student stay in the class is less than 80% of the actual class time, the system will recognize the student's attendance status as attend & incomplete.

Case 3: Student's attendance status is "incomplete"

The student scans the card when he/she first time enter the class. After that, the student moves out from the class during the class on going. Next time, the class entered the leave class time already when the student enters again into the class. The system will recognize the student's attendance status as incomplete.

Case 4: Student's attendance status is "absent"

The student didn't scan his/her NFC card during the system class time.

IV. EVALUATION AND TESTING FOR THE MIDAS

The system is tested for usability, security and evaluated the system on the cost and compare with other similar system.

i) Usability

In order to do the system's function testing, user will log in as the administrator, lecturer and student. Web Application, mobile application, web services and window application were fully tested. Below are the results of the function testing for web application.

Table 1. Web Application Function Testing.

No.	Function	Working
1	User Login	✓
2	Admin Register Student	✓
3	Admin Register Lecturer	✓
4	Admin Register Course for Student	✓
5	Admin Register Course for Lecturer	✓
6	Admin Setting Class Time	✓
7	Lecturer Checking Student Attendance	✓
8	Lecturer Checking Student Movement	✓
9	Class Statistic	✓
10	Student Checking Attendance	✓
11	Student Checking Movement	✓
12	User Forgetting Password	✓
13	User Changing Password	✓

Based on Table 1, we demonstrate that all the functions work successfully. The role of the administrator could register student and lecturer, register course for student and lecturer, and setting the class time and location. The role of lecturer can check student's attendance status, movement and class statistics. The role of student can check his/her own attendance status and movement.

ii) *Security*

ITU-T Recommendation X.800 uses as references to systematically evaluate and define security requirements. In this section, we will evaluate our system with the X.800 Security Standards.

Authentication ensures that entities do communication is the correct entity. This service is ensuring there is no interference from the third of the communication is done. The users of MIDAS need to provide the correct username and password in order to access into the system. The student need to provide his/her own card when record attendance. If he / she failed to do it, he / she is not allowed to proceed the record attendance process.

Access Control is the ability to limit and control access to the host system and applications. Its implementation is done by early identification of the entity that will enter the lines of communication. Prevent users not authorized to access the resource. MIDAS is using role-based access control approach that assigns the users into three roles, which are an Administrator, Lecturer and Student, based on their responsibilities.

Data Confidentiality is the protection of data from unauthorized disclosure. The private data should not disclose to unauthorized individuals. Private record (the images and database record) is protected and administrator is the user who has the privileges to access all the private record.

Data Integrity is the assurance that the data received is really from the data sent from the correct sender. The sensor-biometric approach that using is ensure that the record or any data that send from the legitimate student.

Non-repudiation is providing protection against denial by one of the entities involved in a communication of having participated in all or part of the communication. The student's image will be save into database when he / she is completed the record attendance process.

iii) **Comparison between Systems**

Table 2 shows the comparison between MIDAS and other attendance system in term of effectiveness, security and cost.

Table 2. MIDAS to Other Attendance Systems.

Attendance System	Effective	Security	Cost
RFID-enabled Attendance System (Meng and Mahinderjit Singh, 2015)	High	Low	Low
TouchIn (Ayu and Ahmad, 2014)	High	Low	Low
NFC-Attendance System	High	High	Medium

The effectiveness of three systems that stated above is same because they can record student's attendance by using different approaches. However, the security of MIDAS is greater than the other two attendance systems because it is using multifactor authentication which using NFC and biometric via face. Besides that, NFC commands are extended to add the randomization effect in generating sessions for each event recorded within the web-service database. It has higher security on against replaying events leading to duplications recording and cheating by legitimate and illegitimate users. It is costly than other two attendance systems because of the including of biometric approaches.

V. **SYSTEM DISCUSSION**

The Multifactor Identifications Attendance System (MIDAS) is implemented based on the requirement that discuss during the analysis stage. However, it still has some weakness and threats.

i) *Strength*

This system implemented and meet the requirements of the system design, and the strength of the system. The portability of the system increases because it includes a web application and mobile application. A session ID is generated using complex algorithm based on time and computer's MAC address and assigned to each of the student when the student authorizes his/her NFC card with the server. The system's security increase. The NFC card store a session ID and does not store any student's private information, it is protects user privacy. The accuracy of the system increases because the system combines sensor technology, which is NFC with the biometric authentication, which is face. The cheating issue has been eliminated. NFC commands are extended to add the randomization effect in generating sessions for each event recorded within the web-service database. Globally Unique Identifier (GUID) used to provide randomness based on time is designed using MD5 for data hashing purposes. MIDAS thwart against replaying events leading to duplications

recording and cheating by legitimate and illegitimate users.

ii) Weakness

Same like other system, the system still has some challenges and limitations to be improved.

The system is developed by using the cloud-based face detection and recognition API, so the system will not work if the network failure happens. The accuracy of the face detection and recognition depends heavily on the lighting of the surroundings. For instances, the accuracy of the face detection system will be reduced if the student snaps the photo in the low light condition. The performance of the system relates closely to the action done by the students in recording their attendance themselves. If a student forgets to scan his/her NFC card according to the procedure in case if he has left the class before the class ends, the system will fail to calculate his attendance record correctly. There have different screen resolution for the Android smartphone. The mobile application UI can present perfectly in Samsung Galaxy Note 3 only. If the mobile application install in the android smartphone, which have smaller screen resolution, the UI components will not aligned on the original position in the screen.

iii) Opportunities

There have some opportunities the can let the system become more perfect and advance. The system can combine with subway entrance guard machine, to make the system become more perfect. If the student wants to enter or leave the classroom, they must scan the card, otherwise the door will not open, and the door permits only one student pass for each opening. Nowadays, biometric become more and more popular in the mobile device, such as fingerprint and face. The cost of implement and employment of the system will become cheaper because the system will not rely on the third party for the face detection and recognition.

iv) Threats

The system has some threats. Card cloning is the biggest threat to the system. Although each of the card has a unique ID and it is only readable. The card very difficult to be duplicated because the card

has some limitation at some important fields and it is not writeable. However, there still has some software or machine could clone a same card in the market. The server does not own any certificate for its secure socket layer. Certificate is important to ensure the integrity of data transferred in and out from the server (to prevent man-in-middle attack). In order to get a legal certificate, it must be purchased from any known certificate authority (CA) such as VeriSign.

VI. CONCLUSION AND FUTURE WORK

Multifactor IDentifications Attendance System (MIDAS) is a system, which can help lecturer to take the student's attendance. The system is integrating the face detection and recognition function into NFC. The main outcome for this project especially the important of Multifactor Identification System can stand as an extension to the existing student card currently used in University. In addition, the lack of automated attendance system in the University is the main motivation for implementing this system. The system can combine with subway entrance guard machine. If the student want to enter or leave the classroom, they must scan the card, otherwise the door will not open, and the door permits only one student pass for each opening. This can make the system accuracy on getting the student's attendance and movement become higher

REFERENCES

- S.Kadry; K.Smaili , "A Design and Implementation of A Wireless Iris Recognition Attendance Management System", ISSN 1392 – 124X Information Technology and Control, 2007, Vol.36, No.3.
- G.Talaviya; R.Ramteke; A.K.Shete, "Wireless Fingerprint Based College Attendance System Using Zigbee Technology", International Journal of Engineering and Advance Technology (IJEAT), ISSN: 2249-8958, Volume-2, Issue-3, February 2013.
- S.Chintalapati; M.V. Raghunadh, "Automated attendance management system based on face recognition algorithms," Computational Intelligence and Computing Research (ICCIC), 2013 IEEE International Conference on , vol., no., pp.1,5, 26-28 Dec. 2013, doi: 10.1109/ICCIC.2013.6724266.
- Z.Meng, M.Mahinderjit-Singh, "RFID-enabled Smart Attendance Management System" 2014, Lect. Notes Electrical Eng.,Vol. 329, James J. (Jong Hyuk) Park et al. (Eds): Future Information Technology - II, 978-94-017-9557-9, 328439_1_En.
- M. Ayu and B. Ahmad, 'TouchIn: An NFC Supported Attendance System in a University Environment', *International Journal of Information and Education Technology*, vol. 4, no. 5, pp. 448-453, 2014.

Determinants of Collaboration and Innovation in Creative Industries A Case of the Czech Republic

Jan Stejskal, and Petr Hajek

University of Pardubice, Czech Republic, Europe, {jan.stejskal; petr.hajek}@upce.cz

ABSTRACT

The process of knowledge acquisition, creation and effective utilization is considered a key determinant of innovation activity. Thus, this process becomes a strong source of competitiveness. Knowledge is best transferred in a collaborative environment with strong links between actors. Here we focus on creative industries which can be characterized by a high importance of individuals and their social networks in the local and regional development. The paper deals with the determinants of cooperation and innovation in the creative industries, including knowledge acquisition from various sources, R&D activity and support, and creative individuals. We empirically show that firms from creative industries create innovation mainly through knowledge acquisition from clients and competition. The industry effect was also a significant determinant of innovation activity.

Keywords: Creative industry; knowledge acquisition; collaboration; innovation

I INTRODUCTION

Traditional production sources such as the amount of manpower, natural resources and available capital are necessary for production and economic development (Porter & Van der Linde, 1995). However, at present, these production factors are not sufficient to maintain the market position and mostly not to gain competitiveness in all industries in the globalized world economy (Carney, 1998). During the second half of the 20th century, the significance of the original production factors has decreased and, on the other hand, the importance of knowledge and ability to learn has substantially increased.

Using the knowledge for generating innovations provides a critical source competitiveness too. The concept of competitiveness can be viewed from different perspectives, namely from microeconomic, mezzoeconomic and macro-economic level (Krugman, 1994). In terms of the microeconomic level, competitiveness refers to the ability of the entity to compete, be profitable, develop and grow (Porter, 2004). The competitiveness of firms is derived from the competitive advantages that the firms create through its strategy and actions in the markets (Prokop & Stejskal, 2015). In contrast, the competitiveness of a region at the mezzoeconomic level cannot be

expressed simply as the sum of the efforts and achievements of the firms in the region (Balkyte & Tvaronavičienė, 2010). Regional competitiveness is a result of the activities of various institutions and organizations working in the same environment, including knowledge-intensive organizations such as universities and research organizations (Kitson, Martin & Tyler, 2004).

Innovative processes are considered the key factors of both firm competitiveness and the performance of the whole national economy. They should be therefore supported by public policies (Merickova & Stejskal 2014). Innovations are closely associated with research, development and new technologies. Due to cost-cuts and time-cuts for acquiring new knowledge, firms and other institutions are using collaboration (also in creativity) as a production factor (Laperche, Lefebvre & Langlet, 2011). It is mainly a collaboration of universities and private firms that leads to innovation networks and to the transfer of knowledge (Siegel et al., 2003). Innovations are currently not generated in one firm in isolation, but mostly in the cooperative based networks. Moreover, innovations are relevant to a particular region which provides essential production factors. Thus, there exists a natural connection between these concepts and many studies have analysed firm competitiveness in specific regional and industrial settings.

Recent studies for manufacturing industries have shown that collaboration with other entities allows the effective use of the acquired knowledge, resulting into increased innovation activity (Belderbos et al., 2004). However, little attention has been given to creative industries that have increasing potential to create wealth. This paper aims to fill this gap and analyse the innovation determinants of creative industries in the Czech Republic. Specifically, we use logistic regression to develop two models, one for innovation and the other one for collaboration activity in creative industries.

The remainder of this paper is structured as follows. In the next section, we present a theoretical background for the innovation determinants in creative industries. Section 3 provides the characteristics of the dataset and the research methodology. Section 4 provides the experimental results. In Section 5, we discuss the obtained results and conclude the paper with suggestions for future research.

II THEORETICAL BACKGROUND

In the context of firm innovation activity, regional level is emphasized for several reasons: (a) the regions are increasingly becoming the drivers of development; (b) there is a considerable allocation of production factors, which are moved to places with better (cost) conditions for production; (c) there are no macroeconomic stabilizers at the regional level (such as devaluation of the exchange rates and the flexibility of wages and prices, migration of mobile factors), i.e. capital and labour can become a threat for the region; (d) regional competitiveness is also influenced by the decentralization of public innovation policies, often there is a shift of decision-making and coordination of activities towards the regional level (Porter, 2003; Skokan, 2004; Chapain & De Propris, 2009; Blažek et al., 2011).

Innovative regions have a high level of productivity and labour forces. Regions with a higher productivity usually achieve a higher economic growth. They create and attract investments (especially FDI) and associated jobs. Productivity is defined through the value of goods and services produced per unit of labour and capital and the development in recent years has demonstrated that competitiveness is based on productivity level (Porter, 2004). To maintain competitiveness, firms have fundamentally changed the attitude to production factors in the last decade. Whereas the old approach was based on optimal cost and efficiency, the new one is based on knowledge, innovation and creativity. Productivity is affected not only by policy, law and macro-economic framework but also by innovation milieu and the firm performance and sophistication of firm strategies (Karaev et al., 2007).

With the development of the knowledge economy, the characteristics of competitive advantage have dynamically changed (i.e., the ways of competition, the sources of competitiveness, etc.). Porter et al. (1998) analysed the various stages of competitive development. In the long term, the successful economic development is the process of gradual recovery, when the national innovation environment evolves and promotes the growth and productive ways of competing firms that operate in the same region (Lucas, 1988). The development of the country can be divided into four stages. The first three stages are called economy driven by (a) production factors, (b) efficiency and (c) innovations. These three stages reflect improving national prosperity. The fourth stage is called economy driven by prosperity. When the region gets to this stage, there is a lock-in problem, the dynamics of innovation is reduced and competitiveness can be decreased (Skokan, 2004).

In each of these stages, the economy is stimulated by various determinants; there is another innovative

environment (milieu) where the innovation processes are taking place. The innovation process of enterprises differs substantially between various industries whose innovation activities require specific knowledge bases (Asheim & Gertler, 2005; Hajkova & Hajek, 2014). Asheim et al. (2007) highlight the need for specific knowledge in creative industries. They introduced symbolic knowledge, which is characterized by a distinctive tacit component and high context-specificity. Although creative industries also draw on an analytical knowledge base, which relies on codified knowledge and university-industry links, symbolic knowledge is essential in the creative process. The knowledge required by creative industries is often narrowly tied to a deep understanding of the habits and culture of specific social groups (Asheim & Hansen, 2009). Therefore, this type of knowledge tends to be generated in interpersonal (face-to-face) interactions, this is via socialization. In this process, “know-who” knowledge (of potential collaborators) is acquired.

Contrary to synthetic knowledge, which is typical for engineering industries, symbolic knowledge is less sensitive to regional economic and institutional structures. Another distinction lies in the knowledge creation process. Synthetic knowledge is usually created via interactive learning with customers and suppliers, whereas symbolic knowledge is gained through learning by working in project teams (Asheim & Hansen, 2009). Camelo-Ordaz et al. (2012) included additional determinants of innovation activity for enterprises in creative industries and demonstrated that the entrepreneurial characteristics (previous experience and value system) positively affect the innovation performance of small enterprises in creative industries.

III DATA AND RESEARCH METHODOLOGY

For the data collection we used a harmonized questionnaire of EU Member States from the Community Innovation Survey (CIS). The survey was carried out in the Czech Republic for the period 2008-2010 by combining sample (stratified random sampling) and exhaustive surveys taking into account the regional dimension of NUTS3. In total, data on 5,151 Czech enterprises with at least 10 employees was obtained. Enterprises in selected sectors of creative industries were then incorporated in our sample: Publishing activities (J58.1 - Publishing of books, periodicals and other publishing activities; J58.2 - Software publishing), Computer programming, consultancy and related activities (J62) and Architectural and engineering activities (M71). This list is based on recent literature (Bakhsi et al., 2013; Boix et al., 2013); however, some of the creative industries were not present in the dataset (J59 - Motion picture, video and television programme

production; J60 - Programming and broadcasting activities ; M72 - Scientific research and development; M73 - Advertising and market research; and M74 - Other professional, scientific and technical activities). The basic characteristics of the dataset are given in Table 1. The innovation activity of creative industries was estimated by calculating the number of enterprises that introduced a new product or process to the market. We are aware that this approach may fail to capture all forms of innovation in this sector due to less formalized innovation processes, strong structural dynamics and difficulties in measuring outputs of creative industries (Miles & Green 2008; Kimpeler & Georgieff, 2009). On the other hand, this approach enables comparative analyses in innovation performance across sectors (Müller et al., 2008).

Table 1. Average values of numerical determinants for creative industries.

NACE	J58		J62	
	NO	YES	NO	YES
TURN10	214,163.4	152,374.7	164,882.3	332,779.0
EMP10	99.1	66.9	50.0	125.8
EMPUD	2.9	4.0	4.4	5.0
RRDIN10	522.0	3,077.0	5,280.4	8,496.5
RRDE10	513.6	660.1	973.5	1,729.6
RMAC10	5,781.9	891.6	573.0	4,300.2
ROEK10	1,388.9	272.5	31.4	322.0
RTOT10	8,206.3	4,649.9	6,858.4	14,848.3
N	56	41	122	140
NACE	M71		total	
	NO	YES	NO	YES
TURN10	290,162.8	391,612.7	225,028.9	300,931.9
EMP10	46.1	103.7	57.6	111.6
EMPUD	4.2	4.4	4.0	4.8
RRDIN10	489.7	7,905.1	2,591.7	7,355.1
RRDE10	23.3	143.7	531.0	1,361.4
RMAC10	339.6	1,639.3	1,462.1	3,359.6
ROEK10	63.9	72.2	298.1	287.8
RTOT10	916.6	9,760.3	4,882.9	12,231.6
N	122	18	300	199

Legend: TURN10 – total turnover in 2010, EMP10 – average number of employees in 2010, EMPUD – employees with a university degree, RRDIN10 – in-house R&D expenditure, RRDE10 – external R&D expenditure, RMAC10 – acquisition of equipment, ROEK10 – acquisition of external knowledge, RTOT10 – total innovation expenditure.

Table 1 shows that there are significant differences between sectors. While in the sectors publishing activities (J58) and computer programming (J62) there was a relatively high proportion of innovative enterprises, i.e. 42.3% and 53.4%, respectively, in the sector architectural engineering activities (M71) this proportion was only 12.9%. On the other hand, sector J58 is specific in that the size of innovative enterprises (measured TURN10 and EMP10) was relatively small, even smaller than the size of non-innovative enterprises in this sector. Innovative enterprises in

sector J62 have the highest proportion of employees with a university education. Expenditure on R&D is dominated by in-house R&D expenditure in all sectors. Acquisition of equipment due to innovative activity was the least effective in sector J58.

The determinants of innovation activity in Table 1 estimate: (1) size of enterprise (larger enterprises are generally expected to be more innovative owing to higher resources for innovation projects (Tang, 2006)); (2) human resource competences (the presence of a university-trained workforce can contribute to an enterprise's innovative capabilities (Romijn & Albaladejo, 2002); and (3) technological competences (intensity of R&D usually approximates to R&D expenditure (Souitaris, 2002)).

We further considered the markets in which enterprises sold goods and services, distinguishing local (51.1 % of all enterprises in the dataset), regional (54.1 %), national (85.6 %), EU (49.7 %) and other countries' markets (20.8 %). In total, 37.8 % of the enterprises were part of an enterprise group. International market competition is assumed to require higher innovation activity (Roper & Love, 2002).

Undoubtedly, organisational competencies are another important determinant of innovation activities. These are mainly communications (internal and external) and cooperation (Mention, 2001). Several studies have demonstrated that the new information obtained from other firms and customers (occurring in the innovation environment) is more important than the information obtained from journals, conferences, public agents, private consultants, etc. Firms use the information from suppliers and customers as a stimulus for their innovation.

Cooperation with other companies is a specific source of innovation incentives. It is more important than the collaboration with universities and research institutions (Souitaris, 2002). Based on the analysis of our sample we can state that innovative firms in creative sectors collaborate closely on innovation activity with other enterprises or institutions. Sector J62 shows the most frequent collaboration with other enterprise and sector M71 collaboration with universities or other research institutions.

An important group of determinants supporting innovative firm activity further includes the creativity and creative skilled labour forces. Firms can gain from both internal (own employees) and external sources (bought on the market - including freelancers, consultants, other independent enterprises, other parts of the enterprise group). The largest proportion of the analysed firms used the creative occupation in web design (39.2%), creative occupation in graphic arts (31.7%) and creative occupation in multimedia

(28.1%) as innovation determinants. Individual industries have a similar composition:

- J58 - creative occupation in web design (48.8 %), creative occupation in software development (36.6. %),
- J62 - creative occupation in graphic arts (35.7 %), creative occupation in web design (33.6 %),
- M71 - creative occupation in web design (61.0 %), creative occupation in software development (50.0 %).

The variety of the above-mentioned determinants makes it possible to examine numerous effects on both collaboration and innovation activity in creative industries.

IV EXPERIMENTAL RESULTS

Firstly, a principal component analysis was conducted in order to obtain a set of uncorrelated variables. Sixteen components (factors F_1 to F_{16}) were detected which had eigenvalues greater than one. The components explained 68.7 % of the total variance in the data (Figure 1). The components were further labelled based on the component loadings, see Table 2 for the labels. We used the components as input variables in the logistic regression models. In the collaboration model, the output variable was represented by 0 for no collaboration and 1 for collaboration activity. Similarly, non-innovative and innovative firms were distinguished in the innovation model.

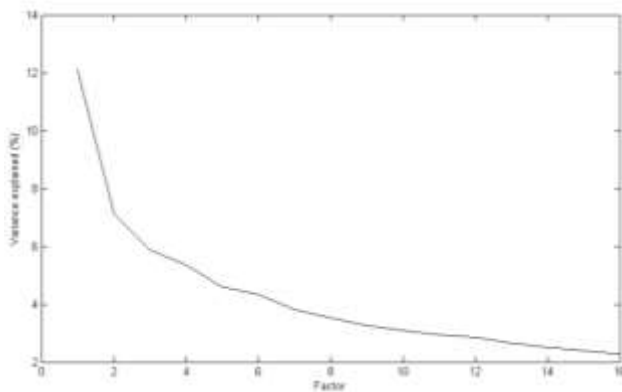

Figure 1. Variance explained by factors with eigenvalues greater than one.

To estimate the quality of the logistic regression models we used approximations of the coefficient of determination, namely Cox and Snell's R^2 which is based on the log likelihoods for the model and baseline model, and Nagelkerke's R^2 which is an adjusted version of the Cox & Snell R^2 . For the collaboration model, information sources were the

only significantly positive determinant of collaboration activity (Table 2).

Table 2. Collaboration and Innovation Logistic Regression Models.

Factor	Collaboration model		Innovation model	
F_1 knowledge acquisition	.541	.000***	.157	.053*
F_2 firm size and expenditure on R&D	.129	.358	.054	.702
F_3 creative individuals	-.151	.146	-.094	.408
F_4 European financial support	.096	.371	.042	.735
F_5 regional market	.037	.734	.105	.378
F_6 university education	-.001	.994	-.011	.935
F_7 group of enterprises	.030	.813	.041	.770
F_8 knowledge acquisition from clients and competition	-.043	.737	.265	.067*
F_9 nat. market and knowledge acquisition from clients	.051	.694	.132	.356
F_{10} nat. market and acquisition of equipment	.181	.264	.042	.794
F_{11} local and regional support	.001	.992	.233	.139
F_{12} knowledge acquisition from suppliers	-.106	.438	-.205	.178
F_{13} Europ.market	.020	.903	-.001	.995
F_{14} multimedia individuals	-.275	.092*	.072	.676
F_{15} other markets	-.110	.476	.275	.099*
F_{16} acquisition of exter. knowledge	-.172	.296	-.037	.837
Industry J58		.346		.088*
Industry J62		.916		.000***
Constant	-.566	.001***	1.496	.000***
Cox & Snell R^2	.251		.227	
Nagelkerke R^2	.339		.267	

Legend: * significant at $P < 0.10$, ** significant at $P < 0.05$, *** significant at $P < 0.01$.

Similarly, information sources were also important for the innovation model, particularly information from clients and competition. In addition, a focus on markets other than those in the EU was a positive determinant of innovation activity in creative industries. The industry effect was significant only in the innovation model. The values of the coefficients showed that while the collaboration activity was partly

explained using the chosen determinants; this was not possible for the innovation activity model, which is strongly dependent on the creative industries in the dataset. Thus, the results supported our primary assumption on knowledge spill-overs and provided a rationale for consequent structural equation models.

V CONCLUSION

Our research contributes to the literature in several ways. Firstly, we have empirically shown that enterprises from creative industries can create spill-overs through innovation collaboration. Secondly, we confirmed that both internal and external collaboration significantly contribute to the creation of innovation. Internal collaboration contributes to a lesser extent than external or their mutual combination. Enterprises can create innovation most effectively by collaborating with other creative enterprises.

In contrast to previous studies on knowledge-based determinants of collaboration and innovation activity (Liao & Wu, 2010), we focused on creative industries. In these creative industries, where a new idea or thought constitutes a new result (typically design, graphic, multimedia), we have shown the greater effect of collaboration and the use of external collaboration or spill-over effects from external collaboration. In contrast, in sectors that use knowledge and information, along with other factors of production only as a means of production, a higher importance of internal collaboration was shown.

The results of our research have other policy implications. These relate mainly to two areas of support. The first is strategic support, which includes support for activities utilizing the collaboration between enterprises or the knowledge-based sector. Here we can see the role of public sector organizations, which can become mediators or institutions for collaboration (as is often the case in industrial clusters for example). The practical implication is support for the establishment of regional innovation systems, which can create a favourable environment for the transfer of tacit knowledge, spill-over effects and their use to create commercial viable results (Matatkova & Stejskal, 2013; Hajek et al., 2014, Stejskal et al. 2015).

The second implication relates to financial support. The research has shown that innovative enterprises in creative industries received more public financial support for innovation activities from all levels of government. Public administration should continue to support innovative enterprises in areas that create commercial viable innovation. However, we should point out a frequently occurring phenomenon called the innovation paradox, which describes the danger of investing public funds into industries and enterprises that fail to transform this support into innovation.

Examination of the individual determinants affecting innovation in creative industries of the Czech economy reveals the following conclusions. The monitored creative industries are specific in terms of the determinants. A key role is played by the acquisition of knowledge, particularly from clients and competitors.

Unlike the manufacturing sector (Belderbos et al. 2004; Murovec & Prodan, 2009) no significant effect was determined based on the size of the enterprise and the amount of expenditure on research and development or on the innovation or collaboration of enterprises. On the other hand, determinants of collaboration between enterprises were common for all of the creative industries examined. Knowledge acquisition and employment of creative individuals (especially from multimedia) leads to greater collaboration in the creative industries.

Surprisingly, we did not observe a direct effect of communication and creative skills on the ability to innovate. This may be explained by the fact that this effect is mainly indirect, requiring collaboration of the enterprise either with other enterprises or with universities and other research institutions. In other words, enterprises alone are not able to transform the communication with their surroundings and their creative staff into innovation. This may be due to the small size of enterprises in the dataset and the nature of the Czech economy, which is a typical export economy dependent on the economies of other countries (especially Germany). Economically significant enterprises are from the manufacturing industry, especially automotive and electrical production. They are more processors than creators. In the context of global production chains (networks) they belong to the so-called third group of suppliers, from which no distinct creativity or ability to create innovation is expected. Other reasons may be the Czech environment, the high level of bureaucracy, complex law enforcement and a high degree of ineffectiveness of both investment and collaboration with scientific research organizations. The latter reason was also demonstrated by our research. In similar economies with comparable characteristics, it is possible to expect completely different determinants which affect collaboration, creativity and innovation. It is necessary, therefore, to subject them to further detailed examination.

ACKNOWLEDGMENT

This work was supported by a grant provided by the scientific research project of the Czech Sciences Foundation Grant No: 14-02836S.

REFERENCES

- Asheim, B. T., & Hansen, H. K. (2009). Knowledge bases, talents, and contexts: On the usefulness of the creative class approach in Sweden. *Economic Geography*, 85(4), 425–442.
- Asheim, B. T., Coenen, L., Moodysson, J., & Vang, J. (2007). Constructing knowledge-based regional advantage: implications for regional innovation policy. *International Journal of Entrepreneurship and Innovation Management*, 7(2), 140–155.
- Asheim, B., & Gertler, M. (2005). *The geography of innovation: Regional innovation systems*. In J. Fagerberg, D.C. Mowery, & R. R. Nelson, The Oxford handbook of innovation (pp. 291–317), Oxford, U.K.: Oxford University Press.
- Bakhshi, H., Freeman, A., & Higgs, P. L. (2013). *A dynamic mapping of the UK's creative industries*. London: CCI.
- Balkyte, A., & Tvaronavičienė, M. (2010). Perception of competitiveness in the context of sustainable development: facets of “sustainable competitiveness”. *Journal of Business Economics and Management*, 11(2), 341–365.
- Belderbos, R., Carree, M., Diederer, B., Lokshin, B., & Veugelers, R. (2004). Heterogeneity in R&D cooperation strategies. *International Journal of Industrial Organization*, 22(8), 1237–1263.
- Blažek, J., Zizalová, P., Rumpel, P., & Skokan, K. (2011). Where does the knowledge for knowledge-intensive industries come from? The case of biotech in Prague and ICT in Ostrava. *European Planning Studies*, 19(7), 1277–1303.
- Boix, R., De-Miguel-Molina, B., & Hervás-Oliver, J. L. (2013). Creative service business and regional performance: evidence for the European regions. *Service Business*, 7(3), 381–398.
- Camelo-Ordaz, C., Fernández-Alles, M., Ruiz-Navarro, J., & Sousa-Ginel, E. (2012). The intrapreneur and innovation in creative firms. *International Small Business Journal*, 30(5), 513–535.
- Carney, M. (1998). The competitiveness of networked production: the role of trust and asset specificity. *Journal of Management Studies*, 35(4), 457–479.
- Hajek, P., Henriques, R., & Hajkova, V. (2014). Visualising components of regional innovation systems using self-organizing maps – Evidence from European regions. *Technological Forecasting and Social Change*, 84, 197–214.
- Hajkova, V., & Hajek, P. (2014). Efficiency of knowledge bases in urban population and economic growth – Evidence from European cities. *Cities*, 40, 11–22.
- Chapain, C., & De Propriis, L. (2009). Drivers and processes of creative industries in cities and regions. *Creative Industries Journal*, 2(1), 9.
- Karaev, A., Lenny Koh, S. C., & Szamosi, L. T. (2007). The cluster approach and SME competitiveness: a review. *Journal of Manufacturing Technology Management*, 18(7), 818–835.
- Kimpeler, S., & Georgieff, P. (2009). *The roles of creative industries in regional innovation and knowledge transfer - The case of Austria*. In E. Villalba (Ed.), Measuring creativity (pp. 207–221). Luxembourg: OPOCE.
- Kitson, M., Martin, R., & Tyler, P. (2004). Regional competitiveness: an elusive yet key concept?. *Regional studies*, 38(9), 991–999.
- Krugman, P. (1994). Competitiveness: a dangerous obsession. *Foreign Affairs – New York*, 73, 28–28.
- Laperche, B., Lefebvre, G., & Langlet, D. (2011). Innovation strategies of industrial groups in the global crisis: Rationalization and new paths. *Technological forecasting and social change*, 78(8), 1319–1331.
- Liao, S. H., & Wu, C. C. (2010). System perspective of knowledge management, organizational learning, and organizational innovation. *Expert Systems with Applications*, 37(2), 1096–1103.
- Lucas, R. E. (1988). On the mechanics of economic development. *Journal of monetary economics*, 22(1), 3–42.
- Matatkova, K., & Stejskal, J. (2013). Descriptive analysis of the regional innovation system – Novel method for public administration. *Transylvanian Review of Administrative Sciences*, 39, 91–107.
- Mention, A. L. (2011). Co-operation and co-opetition as open innovation practices in the service sector: which influence on innovation novelty? *Technovation*, 31(1), 44–53.
- Merickova Mikusova, B., & Stejskal, J. (2014). Value of Collective Consumption Goods. *Politická ekonomie*, 62(2), 216–231.
- Miles, I., & Green, L. (2008). *Hidden innovation in the creative industries*. London: NESTA Research Report.
- Müller, K., Rammer, C., & Trüby, J. (2009). The role of creative industries in industrial innovation. *Innovation*, 11(2), 148–168.
- Murovec, N., & Prodan, I. (2009). Absorptive capacity, its determinants, and influence on innovation output: Cross-cultural validation of the structural model. *Technovation*, 29(12), 859–872.
- Porter, M. (2003). The economic performance of regions. *Regional studies*, 37(6-7), 545–546.
- Porter, M. E. (2004). *Building the microeconomic foundations of prosperity: Findings from the business competitiveness index*. World Competitiveness Report, 2005.
- Porter, M. E., & Porter, M. P. (1998). Location, Clusters, and the "New" Microeconomics of Competition. *Business Economics*, 33(1), 7–13.
- Porter, M. E., & Van der Linde, C. (1995). Toward a new conception of the environment-competitiveness relationship. *The Journal of Economic Perspectives*, 9(4), 97–118.
- Prokop, V., Stejskal, J. (2015). Impacts of local planning to competitiveness index change – using approximate initial analysis to the Czech regions. *WSEAS Transactions on Business and Economics*, 12(1), 279–288.
- Romijn, H., & Albaladejo, M. (2002). Determinants of innovation capability in small electronics and software firms in southeast England. *Research Policy*, 31(7), 1053–1067.
- Roper, S. & Love, J. H. (2002). Innovation and Export Performance: evidence from UK and German Manufacturing Plants. *Research Policy*, 31(7), 1087–1102.
- Siegel, D. S., Waldman, D. A., Atwater, L. E., & Link, A. N. (2003). Commercial knowledge transfers from universities to firms: improving the effectiveness of university–industry collaboration. *The Journal of High Technology Management Research*, 14(1), 111–133.
- Skokan, K. (2004). Competitiveness, innovation and clusters in regional development. 1st ed. Ostrava: Repronis.
- Souitaris, V. (2002). Firm-specific competencies determining technological innovation: A survey in Greece. *R&D Management*, 32(1), 61–77.
- Stejskal, J., Nekolova, K., & Rouag, A. The Use of the Weighted Sum Method to Determine the Level of Development in Regional Innovation Systems – Using Czech Regions as Example. *Ekonomicky casopis*, 63(3), 239–258.
- Tang, J. (2006). Competition and innovation behaviour. *Research Policy*, 35(1), 68–82.

Knowledge Spillover Effects in German Knowledge-Intensive Industries

Petr Hájek, and Jan Stejskal

University of Pardubice, Czech Republic, Europe, {petr.hajek; jan.stejskal}@upce.cz

ABSTRACT

It is widely assumed that firms collaborating in Research and Development (R&D) activities benefit from knowledge spillovers. However, there has been little discussion about the synergistic effects of knowledge spillovers and R&D collaboration. This paper examines the role of three types of knowledge spillovers, namely internal, market and institutional. R&D collaboration mediates the knowledge spillovers effects in the proposed structural equation models. This study demonstrates that German knowledge-intensive firms prefer internal knowledge transfer and market R&D collaboration, respectively. The empirical evidence shows that these tools promote innovation performance. The highest effects are obtained for the combination of market knowledge spillovers (.043***) and market R&D collaboration (.066***). This research thus provides justification for this strategy. It also shows that public financial support represents an effective measure for establishing R&D collaboration based on knowledge spillovers generated in the communication within the firm, in the market and with public institutions. The support of market and institutional R&D collaboration seems to be particularly important.

Keywords: Knowledge spillover, knowledge-intensive industries, innovation, collaboration, Germany

I INTRODUCTION

The great advance in new technologies in the last years has become the driver of the world economy in all industrial sectors (Chesbrough, 2006). Many theoretical and empirical studies have analysed the relationship between innovation capacity and technology-orientation of the firm (Hakala & Kohtamäki, 2011). They confirmed that the use of high-technologies has a positive effect on firm's product and process innovation success. The globalisation leads to higher dynamics of the use of high-technologies. This is associated with the price reduction of the available technologies, increasing scope of their use in "common practice". The rapid tempo of new knowledge application paradoxically requires a high initial investment in science and research (Carpenter & Petersen, 2002).

The firms and organizations that do not have investment necessary for a continuous stream of new technologies, must find new ways to provide them.

More intensive cooperation in innovation processes seems to be a solution; the firms have to cooperate with the specific type of partners (customers, suppliers, competitors, etc.) on innovation processes. The cooperation with a large number of partners forms a cooperative network where every subject involved contributes with specific assets (from common production factors to patents, technology, knowledge or know-how) (Tsai, 2001; Matatkova & Stejskal, 2013; Hajek et al., 2014). These assets form the comparative competitive advantage of the firm. However, the firms have to be willing to share these sources of the advantage in the knowledge network (Meihami & Meihami, 2014).

It should be noted that companies build up and maintain only those relationships which are particularly valuable for them. As companies differ in respect of their needs for networking, it is plausible to assume that companies also differ in respect of the types of external partners they collaborate with (Gemünden, Ritter & Heydebreck, 1996).

The cooperating subjects are forming the networks, which are sometimes based solely on co-operation ties, but the networks based on knowledge usually achieve a greater efficiency. Some authors agree that the network configuration is shaped by both the importance of cooperation (perceived by the members of the network) and the intensity of cooperation. In knowledge networks, the synergistic and knowledge spillover effects occur. These effects significantly increase the efficiency of knowledge and innovation processes (Alegre, Sengupta & Lapedra, 2013; Puškárová & Piribauer, 2016; Wang et al., 2016).

So far, however, there has been little discussion about the synergistic effects of knowledge spillovers and Research and Development (R&D) collaboration. This paper aims to shed some new light on the role of various types of knowledge spillovers on R&D collaboration and innovation performance, respectively. Specifically, it is hypothesized that firm innovation performance is significantly affected by the synergistic effects of knowledge spillovers and R&D collaboration.

The remainder of this paper is structured as follows. In the next section, a theoretical background is presented on knowledge spillover effects. Section 3 provides the research methodology and the characteristics of the data. Section 4 provides the empirical results. In Section 5, the paper is concluded, some political

implications are discussed and future research directions are suggested.

II THEORETICAL BACKGROUND

As mentioned above, knowledge, ability to learn and creativity are precisely those production factors which constitute a source of competitive advantage of different economic actors across the world. The transfer and acquisition of knowledge are realized in networks. Knowledge as a production factor is both easily transferable (codified explicit knowledge) and hardly transferable (un-codified tacit knowledge). Cooperation-based network simplifies the transfer of tacit knowledge. During the cooperation, knowledge articulation and subsequent knowledge transfer is realized. In parallel, knowledge spillover effect occurs too. Generally, the more knowledge is codified, the less possibility of control the owner has. He cannot exercise the ownership rights; there is no control of who receives the tacit knowledge, because its transfer can be influenced by other employees and the transfer also influences others.

However, this does not mean that un-codified knowledge cannot lead to a spillover. Note that this phenomenon is not so common and easy. Tacit knowledge is largely dependent on the absorption ability of firms (and their employees). Mueller (2006) describes the absorption capacity of firms such as the ability to produce, identify and utilize knowledge. This ability depends on the existing knowledge stocks and the absorption capacity of subjects (employees in firms or researchers at universities or research institutions).

Many studies show that knowledge spillovers are an important determinant of the innovative effects (Hajek & Stejskal, 2015). They were defined as unintended, unplanned (and often unwanted) effects, which cause the transfer of knowledge between the different actors. It is a kind of externality, i.e. the transfer does not require any direct costs, and they are incurred outside the market, and have a direct impact on the firms' production function. If there is a knowledge transfer between the originator and the recipient, we call it direct spillover effect. A knowledge transfer realized with the assistance of a third side is then called indirect.

Theoretical approaches define several types of individual spillover effects. Some authors distinguish borrowed knowledge from those obtained by spillover (Lee, 2006), further scholars divide the effects into monetary and non-monetary (Fischer et al., 2009). Monetary spillover effects is embodied in the tradable capital, whereas non-monetary are generated by activity that is financed from the public sector (such new knowledge have the character of a pure collective good). The problem of non-monetary spillover effects is that their transfer cannot be reduced, controlled, and

therefore they do not become a source of competitive advantage. Another way how to divide the spill-over effects is into vertical and horizontal (De Faria et al., 2010). Vertical spillover is associated with the interaction among the suppliers, competitors and customers, and it has a significant impact on research and development activities of the firms. The horizontal spillover occurs when firms are interacting with universities and research institutes, in particular.

There is one important categorization of knowledge spillover effects – according to the subjects that are the source of the effects. We distinguish the *internal knowledge spillovers* that arise in a closed unit (firm) and the effects occur among staff during the work tasks or implementation of research tasks in the firm (Henderson & Cockburn, 1996; Pallotta, Tubaro & Lomi, 2015). There are some advantages attributed to these effects: easy protection of the created knowledge, no spillover outside the firm, and a high level of efficiency (this follows from the very nature of entrepreneurial behavior). On the other hand, internal knowledge spillovers have several disadvantages: the absence of further knowledge expansion and high cost. The second type is *institutional knowledge spillovers* (Audretsch, Hulsbeck & Lehmann, 2012; Casper, 2013). These arise during the implementation of joint projects (often R&D-oriented) between firms and universities (or research institutes). The advantages are as follows: a broad knowledge base, sufficient quantity of skilled science workers from universities, and low cost. The disadvantages include a threat of both free spillover and inflexible university approach (this follows from the behavior of public research subjects). The third type of knowledge spillover effects arises when firms collaborate with any public sector organization - *governmental knowledge spillover effects* (Lichtenberg, 1987; Hayashi, 2003). These are mainly advisory and support public agencies, regional development agencies, associations and professional chambers. This collaboration mode can be beneficial mainly due to the broad involvement of similarly oriented firms, whereas a high inefficiency of the public sector seems to be the disadvantage.

The last type of knowledge spillover is the effects arising from the market knowledge acquisition - *market knowledge spillovers* (where the knowledge acquisition or transfer are taking place in the market and under market conditions; Becker & Dietz, 2004). The advantages of this spillover mode are mentioned as follows: a high speed, technological innovations are found as a "turnkey" solution according to the demand assignment. A high cost and risk of insufficient supply from the market (and semi-market) entities are the disadvantages of market knowledge spillovers.

III DATA AND RESEARCH METHODOLOGY

Our research methodology is based on the conceptual model in Fig. 1, illustrating both the direct and indirect effects of knowledge spillovers on firm innovation performance. Previous literature has shown that knowledge spillovers positively affect firm collaboration and innovation activity (Montoro-Sanchez et al., 2011). As discussed above, collaboration is also regarded as a strong determinant of innovation performance. Therefore, we examined the effects of knowledge spillovers and collaboration in three modes, namely internal, market and institutional. Here, the collaboration (internal, market and institutional) mediates the effects of knowledge spillovers. In addition, the strengths of the effects can be further influenced by R&D expenditure and public financial support (Abramovsky et al., 2009). Therefore, we also included the moderating effects of internal R&D expenditure and public innovation support (local, regional, government and EU).

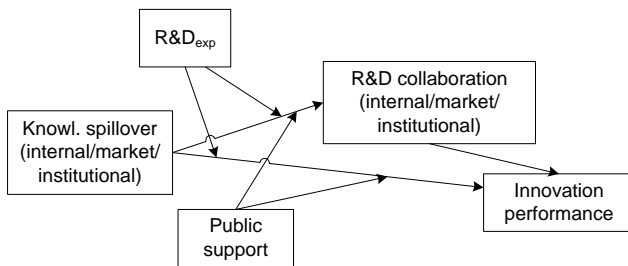

Figure 1. Conceptual Model.

Following previous empirical studies in knowledge spillovers analysis (Hashi and Stojcic, 2013; Stejskal and Hajek, 2015), we used the data collected within the Community Innovation Survey (CIS) carried out Germany for the period 2010-2012. The CIS combines stratified random sampling and exhaustive surveys are thus considered a reliable source of innovation statistics in the EU. The CIS is based on the harmonised questionnaire of EU Member States. The data set contained 6,328 German firms with at least 10 employees. We filtered only the firms in knowledge-intensive industries (NACE rev. 2 activities with more than 33% tertiary educated persons employed). As a result, we obtained data for 2,263 firms. In the data pre-processing step, we used linear regression for the imputation of missing values, where all input variables except the missing one were used to estimate the missing value.

In conformity with prior research (Montoro-Sanchez et al., 2011), we estimated the level of knowledge spillovers from the average degrees of importance of communication sources for innovation activities (measured on a scale from 0 – not used, to 3 – highly important). Thus, internal knowledge spillovers refer to the importance of communication sources within enterprise or enterprise group. Market spillovers come

from suppliers, clients or customers (private and public), competitors and consultants. Finally, institutional spillovers include universities or other higher education institutions and government or public research institutes. The basic characteristics of the data show that firms mostly used internal and private customers' knowledge (Table 1). The same categorization was used for collaboration activities (dummy variable 0 for no and 1 for yes). Table 1 indicates that market collaboration was preferred.

Table 1. Descriptive statistics of knowledge spillovers and collaborative activities.

knowledge spillover	source	average
internal	SENTG	1.67
market	SSUP	0.72
	SCLPR	1.28
	SCLPU	0.65
	SCOM	1.05
	SINS	0.54
institutional	SUNI	0.84
	SGMT	0.21
collaboration		
internal		0.03
market		0.21
institutional		0.05

Legend: SENTG – information within company, SSUP – information from suppliers, SCLPR – information from private customers, SCLPU – information from public customers, SCOM – information from competitors, SINS – information from consultants, SUNI – information from universities, SGMT – information from government institutes.

The internal R&D expenditure included in-house R&D (80% firms), purchase of external R&D (14%), and acquisition of equipment and external knowledge (6%). Furthermore, 12% received local or regional public financial support for innovation activities, 28% government and 12% EU support.

The innovation performance of the industries was estimated by calculating the percentage of total turnover coming from new or significantly improved products introduced during the three years 2010 to 2012. On average, this share was 10% for the knowledge-intensive firms.

To examine the above-mentioned direct and indirect effects, we used structural equation models. In the models, internal/market/institutional knowledge spillovers were used as causal predictors of innovation performance, internal/market/institutional R&D collaboration was a mediator variable, and internal R&D expenditure and public financial support represented the moderators of the causal effect. Thus, we could estimate both the mediation and moderation effects. The modelling was performed using the structural equation models in the Process tool for SPSS (Hayes, 2013).

IV EMPIRICAL RESULTS

To extract uncorrelated input variables for structural equation models, it was necessary to perform a confirmatory factor analysis. We used maximum likelihood estimates to obtain factors. Specifically, we applied this procedure for market and institutional knowledge spillovers because there were more than one source for these input variables. As a result, we obtained one factor for each spillover. Table 2 shows the factor loadings for these new variables. Similarly, we performed the confirmatory factor analysis for internal R&D expenditure and public financial support (Table 3). Using Cronbach's alpha, we confirmed the internal consistency of the factors (all values at least > .60).

Table 2. Confirmatory factor analysis on knowledge spillovers.

	factor loading	institutional	factor loading
market			
suppliers	.669	universities	.808
customers - private	.706	R&D institutes	.808
customers - public	.540		
competitors	.782		
consultants	.523		

Table 3. Confirmatory factor analysis on internal R&D expenditure and public financial support.

internal R&D exp.	factor loading	public fin. support	factor loading
in-house R&D	.447	local/regional	.575
purchase of external R&D	.985	government	.669
acquisition of equip.	.942	EU	.604

Figure 2 shows the results of the structural equation model for internal knowledge spillovers. In this model, internal knowledge spillovers significantly promote both internal R&D collaboration and innovation performance. However, the effect of the internal R&D collaboration on the innovation performance is not significant. This suggests that the use of internal knowledge spillovers directly leads to innovation. Additionally, public financial support plays an important role in promoting innovation performance based on internal knowledge spillovers.

Figure 3 presents the model of market knowledge spillovers. In contrast to the previous model, market R&D collaboration represents a strong mediator of market knowledge spillovers. The indirect effect on innovation performance seems to be even stronger than the direct one. Market R&D collaboration can be significantly increased through public financial support rather than via internal R&D expenditure. On the other hand, internal R&D expenditure promotes innovation performance directly from market knowledge spillovers.

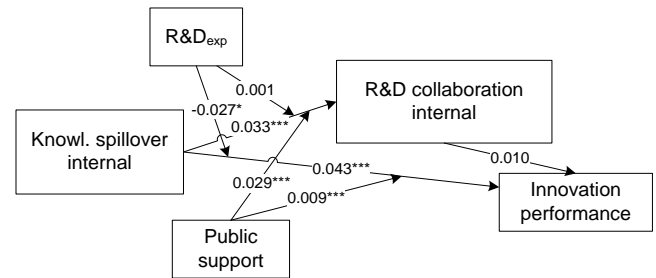

Figure 2. Effects of internal knowledge spillovers.

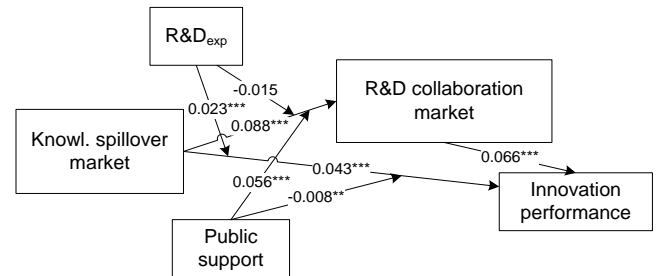

Figure 3. Effects of market knowledge spillovers.

Finally, institutional knowledge spillovers positively influence both innovation performance and institutional R&D collaboration. In addition, the effect of institutional R&D collaboration on innovation performance was also significant. Again, public financial support plays a critical role in supporting institutional R&D collaboration.

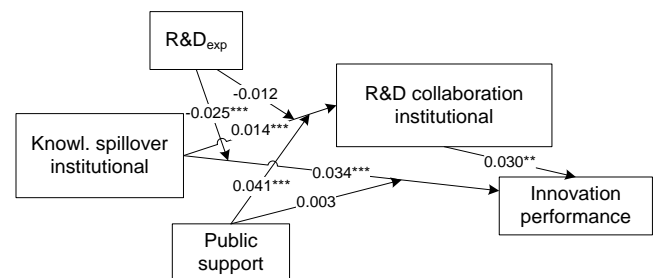

Figure 4. Effects of institutional knowledge spillovers.

V CONCLUSION

The research results confirm that all kinds of knowledge spillover effects have a positive impact on innovation performance. The bidirectional relationship of knowledge effects and collaboration was unveiled in German knowledge-intensive industries. Unveiling of (a) knowledge spillovers role and (b) public sector influence on innovations can help to define with greater precision the public policy and strategy. The effectiveness and outcomes' efficiency will be increased of various government interventions. It will improve both the competitive advantages of economic entities and increase the welfare of the whole society.

The direct and indirect ties were revealed, thanks to them, the innovation performance is realized in practice. All our models confirmed the direct impact of knowledge spillover effects and innovation performance. For the direct tie we further certify that R&D expenditures allocated to direct support of innovative performance have no positive effect. In almost all cases, a negative effect of R&D expenditures was occurred (only in case of the market spillovers, R&D expenditures has positive effects; .023***). Weak and ambiguous effects of public subsidies were identified here.

Further, we analyzed the situation when all selected determinants (spillover effects, collaboration, R&D expenditures, and public support) are involved in innovative activities. The highest effects were measured in case when firms used the market acquisitions (.066***) and institutional collaboration (.030**). Spillover effects are in all three cases positive. The strong positive tie was observed in public subsidies, which aims to innovation collaboration (again, the strongest effects are in market spillovers). R&D expenditures once again have a significant impact. In this case, it should be noted that only in the case of institutional spillovers positive synergy effects were registered. In remaining two cases, there the lower effects were registered due to combination of determinants (even non-significant effect was resulted for indirect market spillover). All results are summarized in Table 4.

The results confirm that different determinants influence the innovative performance with varying degrees. The positive impact of cooperation and public support was shown. Further research should be oriented on investigating of various innovation determinants what are used in high developed countries. The leaders in innovation can provide a benchmark for further continuous improvement.

Table 4. Summary of knowledge spillovers effects (direct/indirect) on innovation performance (+ signif. positive, – sign. negative, 0 – not signif.).

effect	internal	market	institut.
direct	+	+	+
via collab.	+/0	+/+	+/+
R&D exp.	-/0	+/0	-/0
Public supp.	+/+	-/+	0/+

ACKNOWLEDGMENT

This work was supported by a grant provided by the scientific research project of the Czech Sciences Foundation Grant No: 14-02836S.

REFERENCES

Abramovsky, L., Kremp, E., López, A., Schmidt, T., Simpson, H.: Understanding Co-operative Innovative Activity: Evidence from four European Countries. *Economics of Innovation and New Technology* 18(3), 243–265 (2009)

Alegre, J., Sengupta, K., & Lapiedra, R. (2013). Knowledge management and innovation performance in a high-tech SMEs industry. *International Small Business Journal*, 31(4), 454-470.

Audretsch, D. B., Hülsbeck, M., & Lehmann, E. E. (2012). Regional competitiveness, university spillovers, and entrepreneurial activity. *Small Business Economics*, 39(3), 587-601.

Becker, W., & Dietz, J. (2004). R&D cooperation and innovation activities of firms—evidence for the German manufacturing industry. *Research Policy*, 33(2), 209-223.

Carpenter, R. E., & Petersen, B. C. (2002). Capital market imperfections, high-tech investment, and new equity financing. *The Economic Journal*, 112(477), F54-F72.

Casper, S. (2013). The spill-over theory reversed: The impact of regional economies on the commercialization of university science. *Research Policy*, 42(8), 1313-1324.

De Faria, P., Lima, F., & Santos, R. (2010). Cooperation in innovation activities: The importance of partners. *Research Policy*, 39(8), 1082-1092.

Fischer, M. M., Scherngell, T., & Reismann, M. (2009). Knowledge spillovers and total factor productivity: evidence using a spatial panel data model. *Geographical Analysis*, 41(2), 204-220.

Gemünden, H. G., Ritter, T., & Heydebreck, P. (1996). Network configuration and innovation success: An empirical analysis in German high-tech industries. *International Journal of Research in Marketing*, 13(5), 449-462.

Hajek, P., Henriques, R., & Hajkova, V. (2014). Visualising components of regional innovation systems using self-organizing maps – Evidence from European regions. *Technological Forecasting and Social Change*, 84, 197–214.

Hajek, P., & Stejskal, J. (2015). *Predicting the innovation activity of chemical firms using an ensemble of decision trees*. In 11th International Conference on Innovations in Information Technology (IIT), (pp. 35-39). IEEE.

Hakala, H., & Kohtamäki, M. (2011). Configurations of entrepreneurial-customer-and technology orientation: Differences in learning and performance of software companies. *International Journal of Entrepreneurial Behavior & Research*, 17(1), 64-81.

Hashi, I., & Stojčić, N. (2013). The impact of innovation activities on firm performance using a multi-stage model: Evidence from the Community Innovation Survey 4. *Research Policy*, 42(2), 353-366.

Hayashi, T. (2003). Effect of R&D programmes on the formation of university–industry–government networks: comparative analysis of Japanese R&D programmes. *Research Policy*, 32(8), 1421-1442.

Hayes, A. F. (2013). *Introduction to Mediation, Moderation, and Conditional Process Analysis: A Regression-Based Approach*. New York, NY: Guilford Press.

Henderson, R., & Cockburn, I. (1996). Scale, scope, and spillovers: the determinants of research productivity in drug discovery. *The Rand Journal of Economics*, 32-59.

Chesbrough, H. W. (2006). *Open innovation: The new imperative for creating and profiting from technology*. Harvard Business Press.

Lee, G. (2006). The effectiveness of international knowledge spillover channels. *European Economic Review*, 50(8), 2075-2088.

Lichtenberg, F. R. (1987). The effect of government funding on private industrial research and development: a re-assessment. *The Journal of industrial economics*, 97-104.

Matatkova, K., & Stejskal, J. (2013). Descriptive analysis of the regional innovation system – Novel method for public administration. *Transylvanian Review of Administrative Sciences*, 39, 91–107.

Meihami, B., & Meihami, H. (2014). Knowledge Management a way to gain a competitive advantage in firms (evidence of manufacturing companies). *International Letters of Social and Humanistic Sciences*, 3, 80-91.

Montoro-Sánchez, A., Ortiz-de-Urbina-Criado, M., & Mora-Valentín, E. M. (2011). Effects of knowledge spillovers on innovation and collaboration in science and technology parks. *Journal of Knowledge Management*, 15(6), 948-970.

Mueller, P. (2006). Exploring the knowledge filter: How entrepreneurship and university – industry relationships drive economic growth. *Research Policy*, 35(10), 1499-1508.

- Pallotti, F., Tubaro, P., & Lomi, A. (2015). How far do network effects spill over? Evidence from an empirical study of performance differentials in interorganizational networks. *European Management Review*, 12(3), 189-208.
- Pušárová, P., & Piribauer, P. (2016). The impact of knowledge spillovers on total factor productivity revisited: New evidence from selected European capital regions. *Economic Systems*, in press.
- Stejskal, J., & Hajek, P. (2015). *Modelling knowledge spillover effects using moderated and mediation analysis—The case of Czech high-tech industries*. In *Knowledge Management in Organizations* (pp. 329-341). Springer International Publishing.
- Tsai, W. (2001). Knowledge transfer in intraorganizational networks: Effects of network position and absorptive capacity on business unit innovation and performance. *Academy of Management Journal*, 44(5), 996-1004.
- Wang, Z., Cheng, Y., Ye, X., & Wei Y. H. D. (2016). Analyzing the space-time dynamics of innovation in China: ESDA and spatial panel approaches. *Growth and Change*, 47(1), 111-129.

The Optimal LBS Substitution Matrix Technique for Image Hiding

Sunchai Suttipong, and Somboon Anekritmongkol

Rangsit University, Thailand, {sunchai.s57; somboon.a}@rsu.ac.th

ABSTRACT

Least Significant Bit (LBS) Substitution is a hiding information technique by embedded data in the medium and current information won't be recognized. A safety and the quality of the embedded medium are the main point of hiding data because each bits of the medium will be replaced by bits of confidential data. The mediator of data can be changed and noticed and the quality of those data can be measured from Mean Square Error (MSE) and Peak Signal to Noise Ratio (PSNR). LSB substitution matrix was presented to increase the quality of the data which was decreased after the implantation. Every bits of the secret data will be counted as one pixel for changing the position within the matrix. In this current research, the researcher had presented the technique of finding optimal LSB substitution matrix by changing the position of each bits within the matrix integrated with changing the position with the pixel. When comparing the changing position of only with pixel, the changing position with pixel and bit give the better result for MSE and PSNR calculating.

Keywords: Image hiding, least significant bit substitution, LSB substitution matrix, ant colony optimization.

I INTRODUCTION

The communication through the Internet can increase the conveniences of exchanging data but it means that the safety of the data should be focused more. For example, "Operation Shady RAT", their targets are educational institutions throughout the world. A mechanism of an operation is to trick un-careless users opening emails which are created for preparing the back door to users' computers. In the next stages, it will connect to the website and download some files like general HTML or JPEG files. In reality, those files are hidden by the command controlling and can be logged through firewalls without any doubts. These command controlling will order the users' computers receiving an executable code from remote server to allow other users accessing any files within the system (Zielinska et al, 2014).

Besides using hiding data technique (steganography) for illegal purposes, those actions are for a criminal communication, a leakage of internal information systems, and an exchanging of cyber weapons in

other aspects, hiding data technique also can be used to protect copyrights of creative works including some communication of significant data of the government and private in business sector, one interesting technique used to protect some works including songs, movies and works of arts is known as watermarking.

Hiding data (steganography) is often misunderstand with encryption (cryptography) if you look at the etymology derived from Greek, steganography means "covered writing" and cryptography means "secret writing" (Zielinska et al, 2014). An encryption is the technique using cipher algorithm to protect un-allowed users accessing. These are similar to some meaningless code groups or letter groups so these will be forwarded to receivers and they can use cryptographer key changing the information to the default format (Wayner, 2002). This means that the third person can visually see the communication even they can or can't decipher data. This is different from hiding data because those data will be hidden and the third person will not be able to know any communication.

Least Significant Bit (LBS) Substitution is the simple hiding information technique and most researchers give a lot of their attention to it. The data of secret message will be separated and embedded in the lowest bit position in each pixel of cover image for hiding data. After embedding secret message, cover image will be called as stego-image (Katzenbeisser, 2000; Kaur and Kochhar, 2012; Das et al, 2008). In some cases, the quality of stego-image may be low, the introduction of substitution matrix is for enhancing the quality of stego-image (Wang et al., 2001). Every r bit of secret message will be viewed as one pixel and each pixel will be switched positions referenced with substitution matrix. The finding of optimal substitution matrix needs to spend time for a lot of calculating, so Genetic Algorithms (GA) is used to discover optimal substitution matrix taking less time.

Ant Colony Optimization (ACO) is presented by Dorigo which is one of stochastic optimization techniques. Dorigo et al. (Dorigo et al., 1996; Dorigo et al., 1997) and Merkle et al. (Merkle et al., 2002) research have given the result that ACO has more efficiency than GA for solving Traveling Salesman Problem (TSP). Therefore, the research of Ching-Sheng Hsu and Shu-Fen Tu (Ching-Sheng and Shu-Fen, 2010) had taken ACO search an optimal

substitution matrix. Other research also has developed the technique of Wang et al. but the what remains the same is to use pixel for position switching (Chang et al, 2003; Yang and Wang, 2010). Thus, to increase the efficiency of stego-image, this research was conducted the comparison of the result in PSNR calculating between the position switching of pixels with the position switching of pixels and bit that is based on the finding of the optimal substitution matrix with ACO.

II THEORIES AND RELATED RESEARCH

A. The Hiding Data with Simple Least Significant Bit Substitution

Least Significant Bit substitution is the simplest technique of hiding data within the digital images. LBS represents to the position of bit on each byte with the minimum value of the pixel. Thus, when there is a change of bit in each position of pixels, the change of colors within pixels will be soft. For example, there are a pixel $(00100111)_2$ and secret message $(100)_2$, due to the length of the data is equal to three bits so the secret message senders can embed the data in the three rightest bits position of pixels and the result will be shown as $(00100100)_2$. For the receivers, they can extract the secret message by taking the three rightest bits position of pixels out. In case huge secret message, the amounts of bits need to be changed and this would make the differences of stego-image comparing with cover image before the embedding. The simplicity of the technique makes the senders and receivers can embed and pull the data out easily, and the third party can also be easily done as well.

B. The Optimal LSB Substitution

The optimal least significant bit substitution is presented by Wang et al. in 2001 and it aims to increase the qualities and safeties of stego-image. In the first step, the position each r bits of secret message E will be changed by Toral Automorphisms (Voyatzis, 1996) as follow:

$$f(x) = (k_0 + k_1 \times x) \bmod s \quad (1)$$

With that k_0 and k_1 are key x which is the position of r bits and s is the length of Secret message. The highest common factor of k_0 and s is 1. By this method, we can receive secret message which is switched the position E' . Although the stego-image was stolen, the secret message still cannot be accessed without both k_0 and k_1 keys. Calculating substitution matrix $A = \{a_{ij}\}$ can increase the output to calculate PSNR of stego-image. From this procedure, the position of secret message E' will be switched to E^* referenced by matrix A . After two

steps above, E^* will be embedded into the cover image R and the stego-image Z will show up.

Matrix A shown up in second stage will be used for value changing of the secret message. The differences between cover image and stego-image will be made as low as possible. The substitution matrix A is presented as below:

$$A = \{[a_{ij}] | 0 \leq i, j \leq 2^r - 1\} \quad (2)$$

where a_{ij} is a member of set $\{0,1\}$ i and j replaced by horizontal row (row) and vertical row (column) of matrix A and r is the amount of bits per pixel which are used to embed the secret message referenced by matrix A . i is the value of E' replaced by j . If a_{ij} is equal to 1 and there is only one part of vertical and horizontal rows. This part will be equal as 1 and the other parts are equal to 0. The example of the secret image E' and substitution matrix A can be shown as below.

$$E' = \begin{bmatrix} 1 & 3 \\ 0 & 2 \end{bmatrix}_{10} \text{ and } A = \begin{bmatrix} 1 & 0 & 0 & 0 \\ 0 & 0 & 1 & 0 \\ 0 & 1 & 0 & 0 \\ 0 & 0 & 0 & 1 \end{bmatrix}$$

The value s of a_{00} , a_{12} , a_{21} , a_{33} of matrix A have shown that pixel 0, 1, 2, and 3 of E' will be replaced by position 0, 2, 1, and 3. After that, there will be secret image E^* as follow:

$$E^* = \begin{bmatrix} 2 & 3 \\ 0 & 1 \end{bmatrix}_{10}$$

The basic of finding the best of substitution matrix needs to take time for calculating. If the value r is high, all possibility is 2^r so if r is equal to 4, the number of possibilities which must be calculated is 20,922,789,888,000.

Moreover, the research also takes the advantage from hiding data technique within noisy pixel and smoothing pixel areas. 8 bits of each pixel are divided into 2 parts: 4 bits on the left are called as high bits and other 4 bits are called as low byte. Noisy pixel area of the cover image represents to the neighbor of pixel of 8 pixels which have the same high byte value that less than a half or less than 4 pixels. Other pixels apart from those will be called as smoothing pixel. LSB technique can embed the amount of data much more than smoothing pixel

without any observable traces of embedding data on the stego-image.

C. Ant Colony Optimization

Ant colony optimization (ACO) was presented by Dorigo et al. in year 1991 by observing the behaviors of ants (Dorigo et al., 2004). The results had been found that ants could walk through the path of trodden ants. This is because ants can release some chemicals called Pheromone by walking along Pheromone. Ants can find the best route or the shortest of foraging and nesting. From the finding, Dorigo had presented "Ant System" which consists of two parts: the first part had shown the steps of tour construction and the second part had presented Pheromone updating. In the system, ants will stimulate their own path after sampling to find initial capacity. Ants k are determined to stand on point i and point j is another point by applying Random Proportional Rule as below:

$$P_{ij}^k = \frac{[\tau_{il}]^\alpha [\eta_{il}]^\beta}{\sum_{l \in N_i^k} [\tau_{il}]^\alpha [\eta_{il}]^\beta}, \text{ if } j \in N_i^k, \quad (3)$$

where $\eta_{il} = 1/d_{ij}$ and η_{il} is a heuristic value from point i to point j and d_{ij} is the length between point i and point j . τ_{il} is the concentration of pheromone on the path from i to j . p_{ij}^k is the possibility of ant k walking from point i to point j . N_i^k is the set of the neighbor point not including ant k walking to, and α and β are adjustable parameters. Every ant can remember all passed path and calculate a distance of the route. Finally, all ants can walk back to their nest and release Pheromone all the way.

After creating the route, all ants will update the quantity of pheromone during the way back to the nest called "Global Updating". Pheromones are volatile based on this follow formula:

$$\tau_{ij} \leftarrow (1 - \rho)\tau_{ij}, \quad \forall (i, j) \in L \quad (4)$$

where ρ is the rate of the evaporation and $0 < \rho \leq 1$, L is the set of point on the route. When ρ has high value, ants will forget the trodden path. But when ρ has low value, ants can stuck in the same path. The amount of pheromone is increased according to the formula below:

$$\tau_{ij} \leftarrow \tau_{ij} + \sum_{k=1}^m \Delta\tau_{ij}^k, \quad \forall (i, j) \in L \quad (5)$$

where m is the number of all ants and τ_{ij}^k is the number of pheromone released from ants' bodies k on the path from i to j . The variable of $\Delta\tau_{ij}^k$ can be shown as follow:

$$\Delta\tau_{ij}^k = \begin{cases} 1/C^k, & \text{if arc } (i, j) \text{ belong to } T^k, \\ 0, & \text{otherwise.} \end{cases} \quad (6)$$

where T^k is the route created by ant k and C^k is the length of T^k . The increasing of pheromone is the reciprocal of the length of the route. Therefore, we can adjust the amount of pheromone to control the proportion finding the best route.

Next, Dorigo et al. had developed Ant System replacing by Ant Colony System. The difference is the finding of the route or the solution of Ant Colony System based on ants' experiences. Moreover, updating and the evaporation of pheromones are used only with the best route and the update can be appeared both global and local.

D. Finding Optimal LSB Substitution Using ACO

In 2010, Ching-Sheng Hsu and Shu-Fen Tu had presented the technique using ACO for finding matrix A to increase the efficiency of hiding data technique. Firstly, the secret message S will be accessed for changing the position of each pixel by Toral Automorphisms. With this process, we will have the secret message S' . In the system of data embedding on the cover image H , every bit of the secret message S' will be switched the position reference by matrix A from Ant Colony Algorithm (ACO). The first stage is to create an objective function for the substitution matrix. Measuring the quality of digital images can use PSNR (Peak Signal to Noise Ratio) or MSE (Mean Square Error). The objective function represents to the increasing of PSNR results or the decreasing of MSE measured results.

$$f(I') = \sum_{i=0}^{a-1} \sum_{j=0}^{b-1} (I_{ij} - I'_{ij})^2 \quad (7)$$

The next step is to create problem graph. For example, in Figure 1: the problem graph of substitution matrix with the size of 4×4 . Each ant will walk through each node within the graph to create its own route like the ant leave the nest to forage. They have 4 different ways or nodes

v_{00} , v_{10} , v_{20} and v_{30} . When ants choose the path assumed as v_{00} , ants will arrive to v_{00} then they have to decide whether going to any nodes. There will be only three nodes left: v_{11} , v_{21} , v_{31} because each row and column can be set only in one node. After repeating the process until all ants walk to the food, every node which ants walk through will be set as 1 and the other nodes will be set as 0. And we will have the substitution matrix.

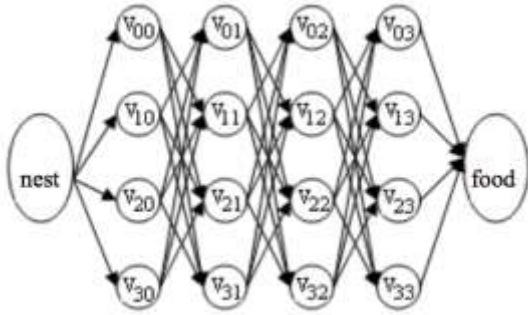

Figure 1. The problem graph

Each parameter used for creating necessary route has to be determined by these follow details:

- m : the number of all ants;
- τ_0 : the initial value of pheromones;
- τ : the concentration of pheromones;
- η : the experiences value;
- α and β = the weight of the concentration of Pheromones and experience value, respectively;
- T : the number of return trips;
- ρ : the parameter of the evaporation of Pheromones;
- q_0 : the random number parameter.

In the part of creating the route, each ant will choose its own path according to the rule below:

$$\tau_{ij}(t+1) = (1 - \rho) \times \tau_{ij}(t) + \rho \times \tau_0 \quad (8)$$

The pattern of pheromones updating can be shown as follows:

$$\tau^{best}(t+1) \rightarrow (1 - \rho) \times \tau^{best}(t) + \rho \left(\frac{1}{\min MSE} \right) \quad (9)$$

When ants create their routes until one set of substitution matrix, the gained result will be used as the determination of value changing in each r bit of S' . Therefore, S' will be changed to S^* and we can embed S^* into H by taking the number of r bits (the rightest R) from the cover image H , replacing R with

S^* and then intergrating with $H-R$. After that we will have the stego-image Z , the receivers will take data S out off the stego-image in each pixel within the amount of r bits and the substitution matrix will switch the position back. S' from switching the position in each r bits by the substitution matrix, there will be decoding process again from the variable k_0 and k_1 by Toral Automorphisms. Finally, the recipient will receive the secret image.

Within the research, the result has been shown that the application of ACO in creating the substitution matrix for increasing the efficiency of hiding data by LBS technique use 21 rounds of walking and the substitution matrix can be created. The good results had shown up even though there will be a lot of possibilities of the paths.

III THE PROPOSED METHOD

This research is based on the basic of hiding image data that have been presented within the report of optimal least significant bit substitution technique (Wang et al., 2001) and the creation of the substitution matrix with ACO (Ching-Sheng and Shu-Fen, 2010) by adding the steps of position switching in each bit. This is to maximize the results of PSNR calculating. The details and processes can be shown as these referencing in Figure 2:

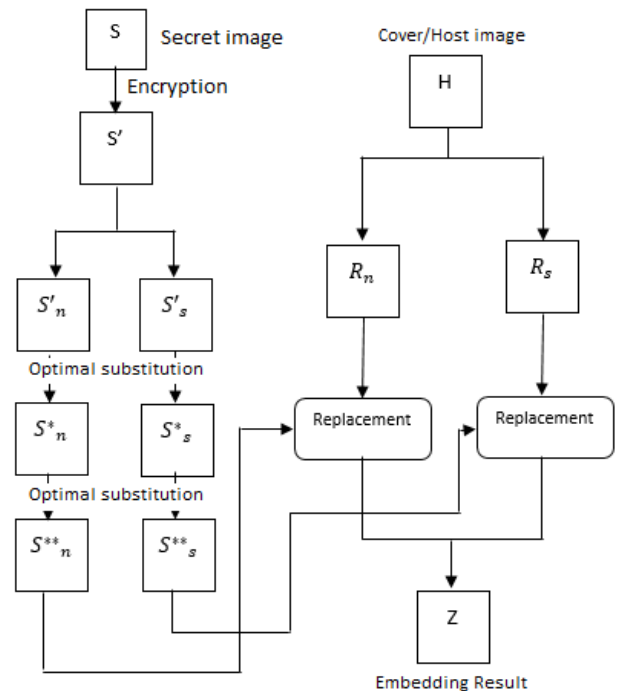

Figure 2. Flowchart of the proposed method

A. The Embedding Process

Encryption. Switching the position of the secret image S in each r bit by Toral Automorphisms to

increase the safety of data, S' will be shown up in this step.

Initial Data. Extract the data from H in the number of r bits in each pixel for comparing the result of MSE calculating to create the substitution matrix. R is divided into two parts: bit from noisy pixel replacing by R_n , smoothing pixel replacing by R_s . Noisy pixel will be embedded in the number of $r = 4$ bits and smoothing pixel will be embedded in the number of $r = 2$ bits.

Construct Substitution Matrix for Pixel. Create problem graph with ACO of both R_n and R_s by using the rule from (Ching-Sheng and Shu-Fen, 2010). When there is one set of round, substitution matrix will be shown up. The switching position of r bits of S'_n for replacing on R_n and S'_s replacing on R_s .

Construct Substitution Matrix for Bit. When switching r bits, there will be S^*_n and S^*_s for creating the problem graph with ACO again as in Eq. (3) by this time, each node of ants' paths will be the switching position of each bit of the secret image. After that S^*_n and S^*_s will be changed the positions by the substitution matrix gaining after S^{**}_n and S^{**}_s .

Embedding. Replace S^{**}_n with R_n and S^{**}_s on R_s and integrate with $H-R$ resulting to stego-image Z .

B. The Extraction Process

Extraction. Get S^{**}_n and S^{**}_s out from stego-image Z .

Recover Bit Position. Change the position of each bit of S^{**}_n and S^{**}_s with the substitution matrix to receive S^*_n and S^*_s .

Recover Pixel Position. Change the position of each r bit of S^*_n and S^*_s with the substitution matrix to receive S' .

Decryption. Reverse the position of S' with the variable of k_0 and k_1 with Toral Automorphisms to receive the secret image.

IV EXPERIMENTAL RESULTS

In this experimental, the researcher had compared hiding data with optimal least significant bit substitution technique combining with the creation of the substitution matrix with ACO, the technique presented in Section III. To add the steps of changing the position in each bit and simple LSB substitution with $r = 4$ bits by the secret image, four images are greyscale size of 256×256 pixels shown up in Figure 3 and the cover image of 3 images size 512×512 pixels shown up in Figure 4. After that the researcher had calculated the result from three techniques and the results had been shown that those presented techniques can maximize the result of PSNR calculating (Eq. (10)) comparing to the

techniques presented in the research (Wang et al., 2001) and (Ching-Sheng and Shu-Fen, 2010) as shown in the Tables 1, 2 and 3.

In Figure 5 had shown the comparison the results of the stego-image. After hiding data with presented techniques and simple LSB substitution, the result had found that presented techniques will not show up any noticed trace



Figure 3. Secret images: greyscale image of 256×256 pixels

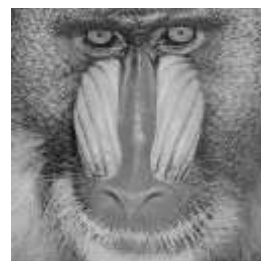
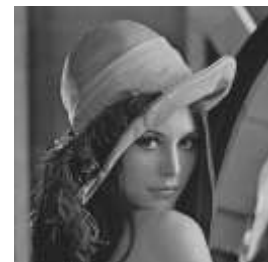

As the computers are more and more integrated into the network, the distribution of digital media is becoming faster, easier, and requiring less effort to make exact copies. One of the major impediments to the lack of effective intellectual property protection of digital media to discourage unauthorized copying and distribution.

Conventionally, in analog world, a printing is signed by the artist to attest the copyright, an identity card is stamped by the state seal to avoid forgery, and the paper money are identified by the embossed portrait, blind kind of hand-written signatures, seals and watermarks have been used from ancient times as a way to identify the source, source of a document or a picture. For example, a priceless painting of the 11th century in National Palace Museum named "Translucence on a Mountain Path" had not been identified as the genuine work.

Figure 4. Cover images: greyscale image of 512×512 pixels

Table 1. The results of PSNR calculating from hiding image data from Figure 3 on the cover image 'Lena' from Figure 4

Techniques	Deer	Zoey	Light-house	Text
Simple LSB Substitution	34.5914	34.6367	35.4246	32.9301
Optimal LSB Substitution	43.9888	43.6377	43.8728	42.9878

The Proposed Method	44.0192	44.0214	44.0714	43.0058
---------------------	---------	---------	---------	---------

Table 2. The results of PSNR calculating from hiding image data from Figure 3 on the cover image 'Baboon' from Figure 4

Techniques	Deer	Zoocy	Light-house	Text
Simple LSB Substitution	34.6234	34.4546	35.315	33.0287
Optimal LSB Substitution	43.6087	43.2658	43.5488	42.4598
The Proposed Method	43.6461	43.645	43.7244	42.5201

Table 3. The results of PSNR calculating from hiding image data from Figure 3 on the cover image 'Text' from Figure 4

Techniques	Deer	Zoocy	Light-house	Text
Simple LSB Substitution	34.4181	31.960	33.6617	35.990
Optimal LSB Substitution	42.7773	41.931	42.5257	42.535
The Proposed Method	42.9093	42.433	42.6993	43.040

$$PSNR = 10 \times \log \frac{255^2}{MSE}, \quad (10)$$

where

$$MSE = \frac{1}{M_1 \times M_2} \sum_{j=1}^{M_1} \sum_{j=1}^{M_2} (c_{ij} - c'_{ij})^2. \quad (11)$$



Figure 5. Stego-image from simple LSB substitution (Left) and presented techniques (Right) with secret image 'Zoocy'

V CONCLUSION

The significant aim of hiding image data is that hidden data will not be noticeable. The proposed method within this research were based on the

available data presented in the findings of optimal least significant bit substitution technique and the creation of the substitution matrix with ACO by adding the steps of changing position of each bit from pixel switching process. The result from the experiment has shown that proposed method can increase the quality of the optimal LSB substitution technique. It means that the safety of hiding data has been increase.

The proposed method is simple and not complicated. Thus, this technique can be integrated with other techniques which have been presented in the current and the quality of the stego-image will not much change. There will be better results and the safety will be maximized because of the various applied techniques. Encoding image data from others will be difficult because they cannot know what technique applied together in the created stego-image.

REFERENCES

- Chang, C., Hsiao, J. and Chan, C. (2003). *Finding optimal least-significant-bit substitution in image hiding by dynamic programming strategy*. Pattern Recognition, 36(7), pp.1583-1595.
- Ching-Sheng, H., & Shu-Fen, T. (2010). *Finding Optimal LSB Substitution Using Ant Colony Optimization Algorithm*. Paper presented at the Communication Software and Networks.
- Das, S., Das, S., Bandopadhyay, B. and Sanyal, S. (2008). *Steganography and Staganalysis: Different Approaches*. Int. Journal of Computers, Information Technology and Engineering (IJCITAE), vol.2, no.1.
- Dorigo, M. and Gambardella, L. (1997). *Ant colony system: a cooperative learning approach to the traveling salesman problem*. IEEE Transactions on Evolutionary Computation, 1(1), pp.53-66.
- Dorigo, M., Maniezzo, V. and Colomi, A. (1996). *Ant system: optimization by a colony of cooperating agents*. IEEE Trans. Syst., Man, Cybern. B, 26(1), pp.29-41..
- Dorigo, M. and Stützle, T. (2004). *Ant colony optimization*. Cambridge, Mass.: MIT Press.
- Katzenbeisser, S. and Petitcolas, F. (2000). *Information hiding techniques for steganography and digital watermarking*. Boston: Artech House.
- Kaur, G. and Kochhar, A. (2012). *A steganography implementation based on LSB & DCT*. International Journal for Science and Emerging Technologies with Latest Trends, vol. 4, no. 1, pp. 35- 41.
- Merkle, D., Middendorf, M. and Schmeck, H. (2002). *Ant colony optimization for resource-constrained project scheduling*. IEEE Transactions on Evolutionary Computation, 6(4), pp.333-346.
- Voyatzis, G. and Pitas, I. (1996). *Applications of toral automorphisms in image watermarking*. Proceedings of IEEE International Conference on Image Processing, vol. 2, 1996, pp. 237-240.
- Wang, R., Lin, C. and Lin, J. (2001). *Image hiding by optimal LSB substitution and genetic algorithm*. Pattern Recognition, 34(3), pp.671-683.
- Wayner, P. (2002). *Disappearing cryptography*. Amsterdam: MK/Morgan Kaufmann Publishers.
- Yang C.-H. And Wang S.-J. (2010). *Transforming LSB Substitution for Image-based Steganography in Matching Algorithms*. Journal of Information Science and Engineering, vol. 26, pp. 1199-1212.
- Zielinska, E., Mazurczyk, W. and Szczypiorski, K. (2014). *Development Trends in Steganography*, Commun. ACM 57(2).

Exploring Affective Mediation Digital Training Model for Training of Trainers (ToT) in Education

Siti Nurhazzalilla Omar, Sobihatun Nur bt Abdul Salam, and Fauziah Abdul Rahim

Universiti Utara Malaysia, Malaysia, snurhazzalilla@yahoo.co.uk, {sobihatun, ziah}@uum.edu.my/

ABSTRACT

Affective mediation in education setting is crucial in order for learners to enhance their motivation to learn, thus will encourage the learners to enjoy the teaching and learning session. Due to its capability therefore the purpose of this paper is to review and examines affective mediation digital training model for ToT (Train of trainers) for the past seven years (2009-2015) and seeks how affective mediation can be implemented in digital training for ToT in education. Ten papers were selected based on the digital training model for ToT in education and this study is related and scoped in Malaysia context. This paper was reviewed based on the components, elements as well as the theory and approaches that are adapted by researchers in their experiment. This study has contributed to the affective mediation development of working model of digital training for TOT in education.

Keywords: digital training for ToT, affective mediation in digital training.

I INTRODUCTION

The purpose of this paper is to review and examines affective mediation digital training model for training-of-trainers (ToT) for the past seven years (2009-2015) and seeks how affective mediation can be implemented in digital training for ToT in education. Since Malaysia is working to become a developed nation, it requires certain need that people are equipped with the basic literacy skills, thus lifelong learning can be achieved in order for the individuals to expand their capacity to learn (Fauziah, 2007).

A lifelong learning on the other hand can be achieved through training which aimed to improve knowledge, skills, and competences within a personal, civic, social, and/or employment related perspective (Georgieva, 2011; Loos & Fowler, 1999). Besides that, the existence of ToT was also beneficial in providing ongoing support to trainees (Suhreinrich, 2011), so that the lifelong learning can be attained. Since technology is being developed impressively, many studies on digital training model, also known as e-training or online training model have been successfully conducted. The models had contributed in human performances in ICT, students' understanding through blended learning in traditional classroom,

visually impaired students to improve their knowledge and IT skills, and helped teacher training agencies in China to increase their ability in implementing e-training during teaching (Pumipuntu, Kidrakarn & Chetakarn, 2015; Sriprasertpap, 2015; Mahajan & Nagendra, 2014; Yan, 2009). The effectiveness and evaluation of training model also have been conducted (Khawaja, 2012; Steensma, 2010; Hiner et al., 2009). However, studies on the affective involvement of trainers when intending to enhance the motivation of learners on digital training model for ToT are still lacking. It was found that the affective mediation elements are crucial in order for learners to enhance their motivation to learn, thus will encourage the learners to enjoy the teaching and learning session (Mahadi & Jafari; Fauziah, 2007).

Affective has been referred to a domain that relates to humans' emotions (Shackleton-Jones, 2010; Fauziah, Hood & Coyle, 2009; Tooman, 2006; Brett, Smith, Price & Huitt, 2003). When emotions were attached in learning process, the sense of information will occur (Shackleton-Jones, 2010) thus one will perform better in her/his learning (Jones & Bouffard, 2012). Mediation on the other hand defined by Fauziah et al. (2009) in their study was referred to the interventions. An intervention is when a mediator provides teaching to enrich the learning process to learners and will engage the learner to learn. When humans' emotions were concerned in the learning process, an effective learning will occur and learners' understandings are mediated affectively.

II DIGITAL TRAINING MODEL

The advances of technologies nowadays have grabbed the attention of educators and researchers (Varank, 2006; Marrison & Frick, 1993). A lot of tools and applications based on technologies have been developed purposely to help trainees engage in learning, increase their motivation to learn, as well as to help them understand the learning better (Nowaczyk & Weber, n.d.; Mishra & Sharma, 2004). The tools and applications were including digital training or also known as e-training and online training. However, developing such training needs a model to ensure that the content of the training meets the objectives and provide a better result (Akyurek, 2005).

From the previous studies, development of a digital training model had improved in students' computer

skills and learning outcomes (Pumipuntu, Kidrakarn & Chetakarn, 2015), helped in blended learning in traditional classroom and in the job training for students, teachers and educational officers (Sriprasertpap, 2015), and imparted IT knowledge and skills to visually impaired students (Mahajan & Nagendra, 2014). On the other hand, the studies on the effectiveness of the digital training model had also shown that a digital training model was effective to improve trainees' knowledge (Steensma & Groeneveld, 2010) and increase employees' job satisfaction (Khawaja, 2012). But, to date there is lacking of study in affective involvement of trainers through digital training model when intending to mediate learners to enhance their motivation to learn. Therefore, there is a need to conduct this study in order to develop an affective mediation digital training model in enhancing trainees' motivation to learn.

III AFFECTIVE MEDIATION IN EDUCATION

Affective mediation according to Fauziah (2007) was related to affective involvement of trainers when intending to enhance the learners' motivation to learn. Trainers also provide learning to learners and encourage them to engage in learning. In addition, the used of dimensions such as global values and praising to learners would enhance the learners' motivation to learn, especially to the less able ones (Fauziah et al., 2009; Fauziah, 2007). The learners' motivation to learn on the other hand is crucial in order for them to feel the learning activities are enjoyable (Mahadi & Jafari, 2012). With the benefits that learners will acquire from the affective mediation, trainers (teachers and/or educators) should see their role as a mediator so as placing affective mediation concept as core to provide better teaching and learning process.

IV METHOD

This study uses Systematic Literature Review (SLR) on ten selected papers that were based on the digital training model for ToT in education and this study is related and scoped in Malaysia context. This paper was reviewed based on the components, elements as well as the theory and approaches that are adapted by researchers in their experiment. The reviewing process started with the relevant selection of sources from the main online database such as ScienceDirect, Emerald Insight, ERIC and little from Google Scholar. The keywords used while searching the sources were such as "training", "training model", "digital training", "e-training", "training of trainers" and "affective mediation". At the initial searches, the ScienceDirect database returned 5,460 open access articles while Emerald Insight and Eric database returned 3,343 and 2,541 respectively when using the relevant keywords. Next, the relevant articles were

selected and being compared to each other to determine any duplication among them. The title and the abstract of the selected articles were then reviewed independently and re-selected based on the criteria of this study. The next part of the review was screening the content of the selected articles to determine the suitability of the article for this study.

A. Review Criteria

At the end of the reviewing process, only 10 articles were selected which related to the digital training model for ToT. Those related articles were selected based on the following criteria:

1. The article is an empirical study related to the digital training model for ToT.
2. The research methods are well explained by the author; means that the author had listed the components of the model and provided a clear reason on why the components were needed. On the other hand, the author also had provided the process on how those components were obtained.
3. The literature from various countries which was published from the year 2009 to 2015; a systematic literature review that tends to review the latest studies which are relevant to the need of this study.
4. Relevant articles; are the articles which were discussed on any online or digital training used to train teachers. Although database searching resulted in massive result, but mostly were discussed on using online or digital training tool to train students in classroom, which is totally not related to this study.

V FINDINGS

From the reviewed studies, three findings were highlighted which has helped to carry out this study. The findings were divided into three; category of study, roles of digital training model, and the domain of studies. Category of study defined the level which the studies reviewed has given impact on this study. Roles of digital training model on the other hand defined the objectives to be achieved from the reviewed studies, and domain of studies highlighted on the field/domain which the studies had contributed into.

A. Category of Study

Table 1 summarizes the result of the reviewed studies. The result was categorized into three types of effects; positive, partially positive and negative or no effect. In summary, a ToTal of six studies reported positive effect from the digital training model which comprised 60% of the ToTal reviewed studies. Three studies reported partially positive and a study

reported no effect which comprised 30% and 10% respectively of the ToTal reviewed studies. The result showed in the Table 1 below.

Table 1. Category of Studies.

Result	Studies	ToTal	Percentage
Positive	(Sriprasertpap, 2015), (Rossemi et al., 2010), (Yan, 2009), (Pumipuntu, Kidrakarn & Chetakarn, 2015), (Mahajan & Nagendra, 2014) and (Syamsul & Norshuhada, 2014)	6	60%
Partially positive	(Groeneveld, 2010), (Khawaja, 2012) and (Ozturan & Kutlu, 2010)	3	30%
No effect	(Sanders & Hampson, 2014)	1	10%

B. Roles of Digital Training Model

It is now necessary to have new generation of training that imports the use of technology such as assistive technology to ensure full access, participation and equality for all trainers including the disabled ones, and in an effort to implement the cost-effective training for trainers (Mahajan & Nagendra, 2014). On the other hand, the use of digital training in this 21st century was beneficial not only to students but also to teachers and educational officers when the digital training was able to go for a lifelong learning (Sriprasertpap, 2015). Akyurek (2005) claimed that a model is needed in developing such training so the content of the training will meet the training objectives. Based on the studies reviewed, the objectives of having digital training was described as roles of digital training that can be referred in the Table 2 below.

Table 2. Roles of Digital Training

Roles	Studies	ToTal	Percentage
Develop IT knowledge	(Mahajan & Nagendra, 2014), (Sriprasertpap, 2015), (Rossemi et al., 2010), (Yan, 2009), (Pumipuntu, Kidrakarn & Chetakarn, 2015), (Norizan & Nor, 2011)	6	50%
Long life / interactive learning	(Sriprasertpap, 2015), (Rossemi et al., 2010), (Pumipuntu, Kidrakarn & Chetakarn, 2015), (Norizan & Nor, 2011)	4	33.3%
Improve knowledge / trainers' satisfaction	(Ozturan & Kutlu, 2010), (Norizan & Nor, 2011)	2	16.7%

As can be seen in the Table 2 above, three main roles of digital training have been highlighted. Out of 10 articles being reviewed, seven of them described that digital training was able to develop IT knowledge, create long life or/and interactive learning, and able to improve knowledge or/and satisfaction among trainers. On the other hand, in order to make the digital training plays its roles, the model of the digital training was developed by implementing relevant components, elements, as well as theories. Those relevant components, elements and theories were gathered and can be referred in the following Table 3.

Table 3. Components and Elements of Digital Training Model

Components	Elements
Student profile, topics to be taught, cognition process, generics contents for every learning styles, tools and equipment, instructional material, administering the training model, certified teacher, training system, training factors (eg. multimedia presentation, interaction and learning instrument), collaborative learning factors (eg. individual accountability, interpersonal skills)	Creativity as the main aim of learning, learning management system, instruction media for learning content, interactive online activities, evaluation, sufficient online resources, a platform with high usability, professional managers, professional tutors

As listed in the Table 3 above, the components and elements has been used to develop digital training model. However, none of them were discussing on the affective mediation theory in digital training that able to enhance trainers' motivation to learn. Thus this study aims to implement the affective mediation theory (Fauziah, 2007) and the relevant components and elements from the reviewed studies into a digital training model in education.

E. Domain of Studies

Table 4 below reported the result of the reviewed studies based on the domain of the target behavior of the digital training model. As a result, education was the major domain of the digital training model with 50 of percentage, followed by social/community and health domain with the percentage of 40 and 10 respectively. This result shows that education is an important domain to have the digital training model. Although health and social/community domain showed less percentage among the studies, however the digital training model can also be implemented in those domain since the use of digital training is not specified to be used in certain domain.

Table 4. Domain of Studies

Domain	Study	ToTal	Percentage
Education	(Mahajan & Nagendra, 2014), (Sriprasertpap, 2015), (Rosseni et al., 2010), (Yan, 2009), (Pumipuntu, Kidrakarn & Chetakarn, 2015),	5	50%
Health	(Mahajan & Nagendra, 2014)	1	10%
Social / Community	(Yan, 2009), (Ozturan & Kutlu, 2010), (Khawaja, 2012), (Steensma & Groeneveld, 2010)	4	40%

VI CONCLUSION

Digital training is an effective way for trainers especially in Malaysia education to meet the challenge of massive and routine training. This study has contributed to the body of knowledge in term of technology development and practical use of the digital training for TOT in education in Malaysia. On the other hand, this study has also contributed to the affective mediation development of working model of digital training for TOT in education. Besides that, this study eventually helps towards sustainable development of the society by enhancing learners' motivation to learn through affective involvement of the trainers in education. It could be a driving factor to improve human psychological in handling emotions or feelings aspects and behaviors problem among the trainees. When trainees' emotions or feelings involved in the learning, an engagement between learners and learning will happen, thus will contribute to effective fun learning. In conclusion, the reviewed studies showed that digital training model can be an effective contribution in developing the digital training tool as a medium to deliver effective training. On the other hand, the theory of affective mediation which able to motivate trainers' to learn could also be implemented in the digital training model.

REFERENCES

Akyurek, F. (2005). A model proposal for educational television programs. *Turkish Online Journal of Distance Education (TOJDE)*, 6(2), 55-64.

Brett, A. M., Smith, M. L., Price, E. A., & Huitt, W. G. (2003). Overview of the Affective Domain. *Educational Psychology Interactive*, 1-21.

Fauziah. (2007). Expanding the capacity to learn through the ECAM model of mediation: Teaching and learning English and Mathematics as a second language in a Malaysian primary school. (Unpublished doctoral dissertation). University of Nottingham, UK.

Fauziah, A. R., Hood, P., & Coyle, D. (2009). 'Becoming Experts': Learning through Mediation. *Malaysian Journal of Learning and Instruction (MJLI)*, 6, 1-21.

Georgieva, N. (2011). Definition of training plan. The EnEf Consortium.

Hiner, C. A., Mandel, B. G., Weaver, M. R., Bruce, D., McLaughlin, R., & Anderson, J. (2009). Effectiveness of a training-of-trainers model in HIV counseling and testing program in the Caribbean Region. *Human Resources for Health*, 1-8.

Jones, S. M., & Bouffard, S. M. (2012). Social and emotional learning in schools from programs to strategies. *Society for Research in Child Development*.

Khawaja, F. L. (2012). An integrated model of training effectiveness and satisfaction with employee development interventions. *Industrial and Commercial Training*, 211-222.

LaVigna, G. W., Christian, L., & Willis, T. J. (2005). Developing behavioral services to meet defined standards with a national system of specialist education services. *Pediatric Rehabilitation*, 144-155.

Mahadi, & Jafari. (2012). Motivation, Its Types, and Its Impacts in Language Learning. *International Journal of Business and Social Science*, 3(24), 230-235.

Mahajan, J., & Nagendra, A. (2014). Developing a Training Model Using Orca (Assistive technology) to Teach IT for Visually Impaired Students. *Symbiosis Institute of Management Studies Annual Research Conference* (pp. 500-5009). Elsevier B. V.

Marrison, D. L., & Frick, M. J. (1993). Computer multimedia instruction versus traditional instruction in post-secondary agricultural education. *Journal of Agriculture Education*, 31-38.

Mishra, S., & Sharma, R. C. (2004). Interactive multimedia in education and training. *The Turkish Online Journal of Distance Education*, 115-122.

Norizan Mat Diah & Nor Azan Mat Zin. 2011. Digital Training Tool Framework for Jawi Character Formation. *Visual Informatics: Sustaining Research and Innovations, Lecture Notes in Computer Science*, 164-175.

Nowaczyk, L., & Weber, A. (n.d.). Multimedia training tools used in teaching work organisation methods in relation to industrial workers of enterprises at SMEs sector. Retrieved from Projects and Products Portal for Leonardo da Vinci: http://www.adam-europe.eu/prj/5423/prj/folder_en.pdf

Pumipuntu, N., Kidrakarn, P., & Chetakarn, S. (2015). The development of web-based collaborative training model for enhancing human performances on ICT for students in Banditpattanasilpa Institute. *Educational Research and Reviews*, 1468-1475.

Shackleton-James, N. (2010, May 5). Towards a working theory of learning: The affective context model. Retrieved from Aconventional not observing any conventions: <http://www.aconventional.com/2010/05/towards-working-theory-of-learning.html>

Sriprasertpap, K. (2015). The Development of Online Training Model for Srinakharinwirot University in Thailand. 7th World Conference on Educational Sciences (pp. 1913-1917). Athens, Greece: Elsevier Ltd.

Steensma, H., & Groeneveld, K. (2010). Evaluating a training using the "four levels model". *Journal of Workplace Learning*, 319-331.

Suhrheinrich, J. (2011). Examining the effectiveness of a train-the-trainer model: Training teachers to use Pivotal Response Training. *SREE Conference*, 1-4.

Tooman, T. (2006). Affective Learning: Activities to Promote Values Comprehension. Retrieved from Soulstice Training: Improving Business from the Inside Out: <http://www.soulsticetraining.com/commentary/affective.html>

Varank, I. (2006). A comparison of a computer-based and lecture-based computer literacy course: A Turkish case. *Eurasia Journal of Mathematics, Science and Technology Education*, 112-123.

Yan, H. (2009). Teacher training in China and a practical model: e-Training Community (eTC). *Campus-Wide Information Systems*, 114-121.

Inter-organizational Knowledge Transfer Processes: An Integrative Perspective

Sommaï Khantong¹, and Mohammad Nazir Ahmad²

¹Maharakham University, Thailand, sommaï.k@acc.msu.ac.th

²University of Technology Malaysia, Malaysia, mnazir@utm.my

ABSTRACT

A process view on inter-organizational knowledge transfer (IOKT) is valuable in developing support strategies and in bridging the gap between human- and technology-oriented approaches for IOKT operations. However, there are few studies explicitly identifying and explaining IOKT processes, and those intensively focus on post-transfer processes and neglect the knowledge source perspective. In this paper, the IOKT processes are identified by focusing on how organizations can receive knowledge from another and by considering both the receiver and source perspectives. From the receiver perspective, the identification of the transfer processes is influenced by absorptive capacity theory. From the provider perspective, knowledge codification is taken into consideration. Based on the integrative perspective, the IOKT processes include identification, codification, acquisition, and interpretation have been established. The practical and research implications of the study for further studies are discussed.

Keywords: Absorptive Capacity, Inter-Organizational Knowledge Transfer Processes, Knowledge Codification, Knowledge Management.

II INTRODUCTION

Knowledge is a critical resource for building and maintaining organizational competitive advantages, especially in today's globally competitive environment (Khamseh & Jolly, 2008). Accordingly, organizations continuously create new knowledge (Choi & Lee, 2002; Kang et al., 2010), and implement knowledge management (KM) as an important strategy to convert the knowledge into organizational competitive advantages (Wu, 2008), which consists of knowledge creation, accumulation, transfer, and application processes (Alavi & Leidner, 2001). Among these processes, knowledge transfer is one of the most important activities of KM (Riege, 2007), especially in inter-organizational contexts (Meier, 2011), which is called inter-organizational knowledge transfer (IOKT).

In the IOKT context, knowledge is transferred through the interaction between two organizations (Easterby-Smith et al., 2008). It is different from transferring

knowledge within the organization and is more complicated because of the multifaceted nature of the boundaries, cultures and processes involved (Inkpen & Tsang, 2005; Martinkenaite, 2011). In response to these challenges, several studies have sought to understand the ways in which organizations manage and gain potential benefits from external knowledge transfer by investigating and examining its various antecedents and consequences (Martinkenaite, 2011). Indeed, they provide the concept of and meaningful knowledge about how to manage and control the IOKT initiatives. However, in practice, when organizations want to transfer the knowledge from external organizations, they require more knowledge about how to do it.

As knowledge can be of different types: individual, social and structured knowledge (David & Fahey, 2000), the type of knowledge to be transferred is a critical factor in deciding on the type of process needed to facilitate the transfer of knowledge (Goh, 2002). Broadly, there are two approaches of knowledge transfer, namely unstructured and structured approaches (Chen & McQueen, 2010). This paper concerns only with the transfer of structured knowledge that is embedded in organizational systems, its processes, tools and routines, and focuses on the structured approach for transferring this type of knowledge as it is designed to ensure that the transfer of knowledge takes place between the organizations, which requires a very structured transfer process. In addition, as organizations typically implement KM projects based on human- and technology-oriented approaches (Inkinen, 2016), an emphasis on the processes is critical for bridging the gap between these approaches; the processes determine the need for technology and define the roles of and knowledge needed by human (Maier & Remus, 2003). Therefore, it is important to investigate the processes of IOKT, by which the most efficient and effective strategies to support these processes can be developed. Nevertheless, there are few studies explicitly identifying and explaining the transfer processes. Alavi and Leidner (2001) state that the balance between the processes of knowledge receiver and knowledge provider is crucial for knowledge transfer. Therefore, this paper aims to identify the processes of IOKT by considering both the source and receiver perspectives.

The remaining sections are organized as follows: the following section presents background concept of inter-organizational knowledge transfer from external organizations, and reviews some related works on IOKT processes, and summarizes the absorptive capacity theory and knowledge codification. The third section presents and describes the transfer processes identified in the present study. The final section discusses some possible directions for future research and concludes the paper.

III RESEARCH BACKGROUND

A. The Concept of IOKT

IOKT refers to the flow of knowledge from one organization to another (Chou et al., 2015; Sussman & Siegal, 2003). It is seen as an essential part of KM dealing with the flow of knowledge from external organizations. In any case of IOKT, the objective is to facilitate the flow of knowledge between collaborating organizations (Bou-Llusar & Segarra-Ciprés, 2006). In this context, there are two main components involving in the transfer processes: the source who shares knowledge and the receiver who acquires that knowledge (Liyanage et al., 2009). As such, in this paper, IOKT focuses on the process related to the flow of knowledge from the source organization to the receiver organization. As shown in Figure 1, IOKT processes aim to facilitate the flow of knowledge from external knowledge sources into the organization, which may support other processes of KM in the organization such as knowledge creation, capture, application and integration. In this definition, IOKT is achieved when the receiver organization obtains the knowledge transferred from the source organization.

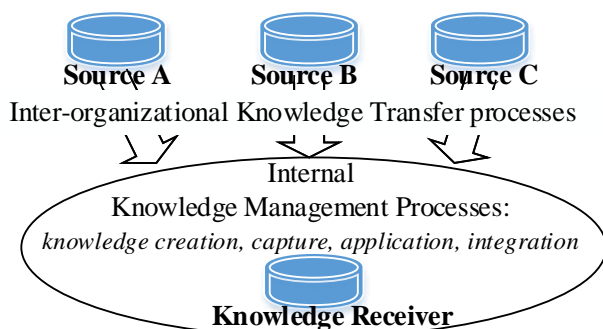

Figure 1. The IOKT Concept

B. IOKT Processes

Knowledge transfer approaches can be broadly divided into structured and unstructured approaches (Chen & McQueen, 2010). The unstructured approach is an informal, unplanned and spontaneous transfer process. In contrast, the structured approach is formal, planned and is an intentional transfer process. This paper focuses on the structured approach as it is designed to ensure that the transfer of knowledge takes place between the organizations, which requires

a very structured transfer process. However, there are few studies that explicitly identify and describe the various processes involved in the transfer of knowledge. The studies discussed in this section are representative of efforts to identify the knowledge transfer processes.

Chua and Pan (2008) state that the knowledge transfer process is similar to organizational learning sub-processes that consist of (1) knowledge acquisition – knowledge is acquired from the source, (2) Information distribution – information is distributed in the organization, (3) Information interpretation – the meaning and understanding of the information is developed, and (4) Organizational memory – knowledge is stored for future use.

Abou-Zeid (2005) conceptualizes the transfer of knowledge as a process in which the knowledge created within one organizational context is re-created and utilized in another organizational context. The knowledge transfer processes include (1) initialization – selection of the knowledge source and the type of collaborative arrangement; (2) inter-relation – initiating constructive dialogues between the source and receiver organizations and establishing the transfer conduits for transferring the knowledge; (3) implementation – unpacking and interpreting the newly acquired knowledge, and applying such knowledge in the receiver organization; and (4) internalization – routinizing and institutionalizing the new knowledge within the receiver organization.

Vito Albino et al. (1998) state that the knowledge transfer process begins with the transfer of information and ends with the interpretation of the transferred information to become knowledge through a learning process, which consist of (1) acquisition – simply acquiring information from another organization; (2) communication – distributing the acquired knowledge in the organization; (3) application – applying the communicated knowledge to be retained in the organization; and (4) assimilation – assimilating the results of applying the transferred knowledge.

Liyanage et al. (2009) propose that, based on communication and translation theories, the transfer processes consist of (1) awareness – the appropriate or valuable knowledge is identified to be transferred; (2) acquisition – the knowledge is acquired from the source; (3) transformation – the acquired knowledge is transformed by simply adding or deleting knowledge or by means of translation; (4) association – the transferred knowledge is associated with the internal needs; and (5) application – the useful knowledge is applied in the organization in order to create value.

Szulanski (2000) argues that the transfer of knowledge should be emphasized as the process of knowledge

movement, not a gradual process of dissemination. Therefore, the transfer of knowledge is seen as a process of dyadic exchanges of knowledge between the source and the recipient, which includes (1) initiation – the consideration of the feasibility of the transfer that leads to the decision to transfer, which involves the identification of the need and the

potential knowledge to meet that need; (2) implementation – the actual flow of the knowledge from the source to the receiver; (3) ramping-up – the initial use of the transferred knowledge by the receiver; and (4) integration – the gradual institutionalization of the new routines that result from the use of the transferred knowledge.

Table 1. Knowledge Transfer Processes Identified in Prior Studies

Study	Concept used	Pre-transfer	Transfer	Post-transfer
Chua and Pan (2008)	Organizational learning	NA	Acquisition	Information distribution, Information interpretation, Organizational memory
Abou-Zeid (2005)	Knowledge re-creation	Initialization	Inter-relation	Implementation, Internalization
Vito Albino et al. (1998)	Learning processes	N/A	Acquisition	Communication, Application, Assimilation
Liyanage et al. (2009)	Communication and translation theories	Awareness	Acquisition	Transformation, Association, Application
Szulanski (2000)	Knowledge movement processes	Initiation	Implementation	Ramping-up, Integration

The studies mentioned above use different concepts to identify the transfer processes, but these processes are likely to be similar in terms of the phases of the process (see Table 1). In addition, they intensively focus on post-transfer processes such as application, integration and internalization. It seems that the processes needed to foster obtaining external knowledge may not be adequate, while they are a prerequisite for other KM processes in utilizing the transferred knowledge. Further, as the IOKT concept defined in this paper, the authors argue that the transfer of knowledge and the application or exploitation of transferred knowledge may not occur in the same process. The knowledge has to be transferred before it is able to be utilized.

Knowledge application involves the use of knowledge to create value, whereas knowledge transfer focuses on how the organizations can receive knowledge from other organizations (Meier, 2011). Moreover, these studies neglect the perspective of the source organization. The IOKT processes involves both the source and receiver organizations (Easterby-Smith et al., 2008; Liyanage et al., 2009) and the balance between the processes of the receiver and the provider is crucial for knowledge transfer (Alavi & Leidner, 2001). Therefore, it is important to identify the transfer processes by considering both the two perspectives. This paper tries to do this by using absorptive capacity theory, from the receiver perspective, and by taking into account knowledge codification, from the source perspective. These will be described in the following sub-sections.

C. Absorptive Capacity Theory

The absorptive capacity (ACAP) theory has become one of the most prominent constructs in the area of knowledge transfer (Van Wijk et al., 2008). Several studies have indicated that a receiver's absorptive capacity impacts the level of knowledge transfer (Roberts et al., 2012). The ability of organizations to absorb new external knowledge is crucial for facilitating knowledge transfer across organizations (Easterby-Smith et al., 2008; Martinkenaite, 2011). Accordingly, from the receiver perspective, the theory of ACAP is influential in identifying the processes of IOKT.

ACAP is defined as “a set of organizational routines and strategic processes by which firms acquire, assimilate, transform, and exploit knowledge for purpose of value creation” (Zahra & George, 2002, p. 186). Therefore, ACAP consists of knowledge acquisition, assimilation, transformation and exploitation. These components are subsequent to each other, and are categorized in two subsets: potential and realized ACAP. The former refers to the ability to acquire and assimilate new knowledge, whereas the latter refers to the ability to transform and exploit this knowledge. These two subsets have separate but complementary roles.

Todorova and Durisin (2007) argue that Zahra and George's model is not built systematically enough on Cohen and Levinthal's (1990) original contributions and that there are some gaps and ambiguities in their model. Therefore, Zahra and George's model was refined in which the “ability to recognize the value” component was reintroduced from the original conceptualization by Cohen and Levinthal (1990) as

the first component. Recognizing the value of new knowledge is about understanding the potential value of the new external knowledge, whereas acquisition mainly focuses on the intensity, speed and effort to gather knowledge (Todorova & Durisin, 2007). Accordingly, ACAP consists of recognizing the value, acquisition, assimilation, transformation and exploitation of new external knowledge. As shown in Figure 2, the three first components are categorized as potential ACAP, whereas the two latter are components of realized ACAP.

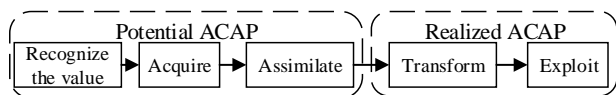

Figure 2. Components of Absorptive Capacity

D. Knowledge Codification

Knowledge codification may be essential for the transfer of external knowledge. Knowledge that is codified and is in explicit form makes it possible to exchange, share and disseminate (Janicot & Mignon, 2012). Accordingly, codification strategies are required to facilitate flows of organizational knowledge (Schulz & Jobe, 2001; Yang, 2010), especially for KM implementing based on system or technology strategies that focus on codifying and storing knowledge via information technology (Choi & Lee, 2002).

Knowledge codification is seen as “the process of conversion of knowledge into messages which can then be processed as information” (Cowan & Foray, 1997, p. 596). From this definition, there are two aspects of the codification of knowledge in which the information is created (Hall, 2006): codification of tacit knowledge, and codification of information. Tacit knowledge codification involves the use of language to explain, describe and articulate, and so on. It can be taken as a process by which the knowledge is transformed to be explicit. In the case of the codification of information, codification is of knowledge that has already been codified into information. This codification can be seen as a process of classification or organization of information. However, the tacit and the codified forms are not substitutes, but rather complements (Cohendet & Meyer-Krahmer, 2001). Typically, the key issue of codification is to convert knowledge into information that is represented in an object (the explicit form) such as expressed in documents or manuals. It is the process to represent the knowledge into the explicit form by linguistic and symbolic means (Senaratne & Malewana, 2011). In other words, knowledge becomes information, when it is presented in the form of text, graphics, words, or other symbolic forms (Alavi & Leidner, 2001).

IV IOKT PROCESSES IDENTIFICATION

In this paper, the identification of IOKT processes is made from the perspectives of the receiver and the source involving in the transfer processes. From the receiver perspective, the theory of ACAP is useful for identifying the IOKT processes. This paper follows the model by Zahra and George (2002) that distinguishes ACAP into potential ACAP and realized ACAP. Consistent with our definition of IOKT, the transfer process should be separated from the process of knowledge application or exploitation. It should mainly focus on how organizations can receive knowledge from other organizations. Therefore, knowledge exploitation is not considered to be included in the IOKT process as it is the process of utilizing or applying the transferred knowledge. Meanwhile, this paper also follows the model by Todorova and Durisin (2007) that reintroduces the “ability to recognize the value” as the first component. Accordingly, from the receiver perspective, IOKT is described as being dependent on the organization’s ability to recognize the value of new external knowledge, to acquire and assimilate that knowledge. Furthermore, from the source perspective, IOKT is also dependent on the organization’s ability to codify knowledge to be transferred. The following subsections describe these components in detail.

A. Ability to Recognize the Value of New External Knowledge

The ability to recognize the value of new external knowledge involves understanding and valuing new external knowledge, which is influenced by prior knowledge related to the new knowledge (Cohen & Levinthal, 1990). It should be the first component before acquisition because acquisition mainly directs attention to the intensity, speed and effort to gather knowledge; consequently, the ability to motivate these efforts by understanding the potential value of such knowledge may be ignored (Todorova & Durisin, 2007). This has crucial implications for IOKT. The transfer of knowledge from external organizations does not occur automatically; rather, it occurs when an organization understands the potential value of the external knowledge or has the motivation to seek the transfer of that knowledge. Accordingly, the motivation to seek the transfer of knowledge is one of the most important antecedents of IOKT (Easterby-Smith et al., 2008; Martinkenaite, 2011). In this paper, this process is referred to as “identification”, whereby knowledge is identified for transfer through recognition of its potential value. Several activities are involved, such as identifying the type of knowledge to be transferred, evaluating the expected outcome and potential source, together with the type of arrangement to be established with the source of the required knowledge (Abou-Zeid, 2005).

B. Ability to Codify Identified Knowledge

In the literature, it has been suggested that the ability to codify knowledge enables the ease and speed of the transfer of knowledge (Bou-Llusar & Segarra-Ciprés, 2006; Smeets & Bosker, 2011). Especially, in the IT-based system, transferring knowledge that is codified in the form of electronic documents saves times and reduces the access cost (Janicot & Mignon, 2012). In fact, knowledge that is codified, making it easier to transfer than tacit knowledge that is abstract (Dhanaraj et al., 2004; Hau & Evangelista, 2007).

Knowledge that can be transferred needs to be represented in a code which can range from natural language to numbers, from analytical models to images (Albino et al., 2004). Therefore, knowledge codification is necessary for organizations wanting to transfer knowledge to others, especially the transfer of organizational knowledge that is the focus of this paper. Accordingly, before acquiring, knowledge needs to be codified into information at the source organization in order to facilitate the flow of knowledge to the receiver. In this process, knowledge is codified into information representing in an object such as documents or manuals, which is influenced by cultural background, goals and experience of the subject who performs codification, depending on the knowledge transfer context (Albino et al., 2004).

C. Ability to Acquire Codified Knowledge

Knowledge acquisition is defined as the process in which the codified knowledge that has been identified to be transferred is acquired from the source organization by the receiver organization. From the absorptive capacity perspective, there are three attributes of an organization's efforts in the new knowledge acquisition that influence absorptive capacity: intensity, speed, and direction (Zahra & George, 2002). The intensity and speed in gathering knowledge can determine the quality of an organization's acquisition capabilities, whereas the direction of accumulating knowledge can affect the paths that the organization follows in obtaining external knowledge (Zahra & George, 2002). However, these activities vary in their richness and complexity, and expertise from different domains in the organization is required in order for the activities to be accomplished (Zahra & George, 2002). In this paper, knowledge acquisition is identified as an important process in IOKT as it involves the actual transfer of the required knowledge from the source organization to the receiver organization. Once the identified knowledge to be transferred is codified, the knowledge is acquired and then flows from the source to the receiver organization.

D. Ability to Assimilate Acquired Knowledge

Knowledge assimilation refers to interpreting, processing, analyzing and understanding the new knowledge acquired from external sources (Zahra & George, 2002). In this paper, this process is referred to as "interpretation" and is considered to be the last process of IOKT in which the newly acquired knowledge is processed. Once the knowledge is acquired, the organization has to understand and interpret what it has acquired. This can be seen as the process of reconstituting acquired knowledge in the form of information into knowledge. Information that is interpreted to be used in a particular context can be considered as knowledge. Therefore, interpretation is an important activity in the knowledge transfer process by which the information acquired from the source is turned into knowledge at the receiver (Garavelli et al., 2002).

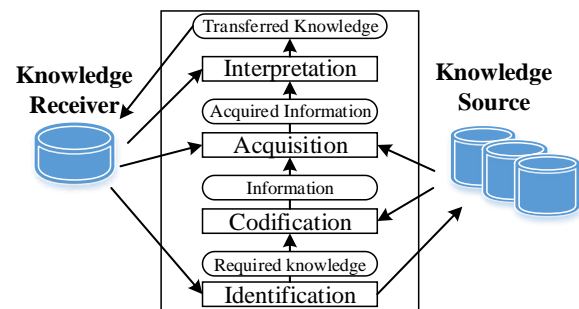

Figure 3. IOKT Processes

As indicated above, the transfer starts with the prospective receiver organization identifying what knowledge is required to be transferred from external organizations by recognizing its potential value, and which organization is appropriate to provide that knowledge. Before knowledge acquisition, the identified knowledge needs to be codified into information by the source organization. Then, the codified knowledge in the form of information is acquired from the source organization. The last process is interpretation where the acquired information is turned into knowledge. Figure 3 shows the sequence of these processes.

V CONCLUSION AND FUTURE RESEARCH

In this paper, the identification of IOKT processes is made from both knowledge receiver and knowledge source perspectives, which is different from previous studies that neglect the source perspective. From the receiver perspective, the transfer processes is influenced by the ACAP theory. From the source perspective, knowledge codification processes of the knowledge provider is taken into consideration. Further, the present paper considers that IOKT processes should be separated from the process of application or utilization of transferred knowledge. Accordingly, based on the integrative perspective, IOKT consists of the processes of identification,

codification, acquisition, and interpretation. These processes are essential to be sufficiently addressed in order to ensure that the transfer of external knowledge can be achieved.

This paper provides an understanding of IOKT in terms of the processes. It has some practical and research implications. For practical implications, this study provides a concrete way to conduct the external knowledge transfer initiatives. For research implications, the proposed IOKT processes would be used as the basis for future research with the ultimate goal of developing the most efficient and effective strategies, both human-and technology-based strategies, for supporting and operationalizing these processes. It would be helpful to determine human activities and roles and the need for and value of technology that are relevant in supporting IOKT effectively in a specific context. It serves as a procedure and methods to guide the implementation of the support strategies for IOKT. In particular for technology-based strategies, several technologies can be used to enhance the efficiency of knowledge transfer by increasing the speed of transfer and decreasing costs due to time and distance. However, without human intervention, technology is insufficient. Therefore, it is interesting for future research to explore in details the roles and value of technology as well as human roles in supporting and operationalizing the IOKT processes.

REFERENCES

- Abou-Zeid, E. S. (2005). A culturally aware model of inter-organizational knowledge transfer. *Knowledge Management Research & Practice*, 3(3), 146-155.
- Alavi, M., & Leidner, D. E. (2001). Review: Knowledge Management and Knowledge Management Systems: Conceptual Foundations and Research Issues. *MIS Quarterly*, 25(1), 107-136.
- Albino, V., Garavelli, A. C., & Gorgoglione, M. (2004). Organization and technology in knowledge transfer. *Benchmarking: An International Journal*, 11(6), 584-600.
- Albino, V., Garavelli, A. C., & Schiuma, G. (1998). Knowledge transfer and inter-firm relationships in industrial districts: the role of the leader firm. *Technovation*, 19(1), 53-63.
- Bou - Llusar, J. C., & Segarra - Ciprés, M. (2006). Strategic knowledge transfer and its implications for competitive advantage: an integrative conceptual framework. *Journal of Knowledge Management*, 10(4), 100-112.
- Chen, J., & McQueen, R. J. (2010). Knowledge transfer processes for different experience levels of knowledge recipients at an offshore technical support center. *Information Technology & People*, 23(1), 54-79.
- Choi, B., & Lee, H. (2002). Knowledge management strategy and its link to knowledge creation process. *Expert Systems with Applications*, 23(3), 173-187.
- Chou, C.-H., Wang, Y.-S., & Tang, T.-I. (2015). Exploring the determinants of knowledge adoption in virtual communities: A social influence perspective. *International Journal of Information Management*, 35(3), 364-376.
- Chua, A. L., & Pan, S. L. (2008). Knowledge transfer and organizational learning in IS offshore sourcing. *Omega*, 36(2), 267-281.
- Cohen, W. M., & Levinthal, D. A. (1990). Absorptive Capacity: A New Perspective on Learning and Innovation. *Administrative Science Quarterly*, 35(1), 128-152.
- Cohendet, P., & Meyer-Krahmer, F. (2001). The theoretical and policy implications of knowledge codification. *Research Policy*, 30(9), 1563-1591.
- Cowan, R., & Foray, D. (1997). The Economics of Codification and the Diffusion of Knowledge. *Industrial and Corporate Change*, 6(3), 595-622.
- David, W. D. L., & Fahey, L. (2000). Diagnosing Cultural Barriers to Knowledge Management. *The Academy of Management Executive (1993-2005)*, 14(4), 113-127.
- Dhanaraj, C., Lyles, M. A., Steensma, H. K., & Tihanyi, L. (2004). Managing tacit and explicit knowledge transfer in IJVs: the role of relational embeddedness and the impact on performance. *J Int Bus Stud*, 35(5), 428-442.
- Easterby-Smith, M., Lyles, M. A., & Tsang, E. W. K. (2008). Inter-Organizational Knowledge Transfer: Current Themes and Future Prospects. *Journal of Management Studies*, 45(4), 677-690.
- Garavelli, A. C., Gorgoglione, M., & Scozzi, B. (2002). Managing knowledge transfer by knowledge technologies. *Technovation*, 22(5), 269-279.
- Goh, S. C. (2002). Managing effective knowledge transfer: an integrative framework and some practice implications. *Journal of Knowledge Management*, 6(1), 23-30.
- Hall, M. (2006). Knowledge management and the limits of knowledge codification. *Journal of Knowledge Management*, 10(3), 117-126.
- Hau, L. N., & Evangelista, F. (2007). Acquiring tacit and explicit marketing knowledge from foreign partners in IJVs. *Journal of Business Research*, 60(11), 1152-1165.
- Inkinen, H. (2016). Review of empirical research on knowledge management practices and firm performance. *Journal of Knowledge Management*, 20(2), 230-257.
- Inkpen, A. C., & Tsang, E. W. K. (2005). Social Capital, Networks, and Knowledge Transfer. *Academy of Management Review*, 30(1), 146-165.
- Janicot, C., & Mignon, S. (2012). Knowledge codification in audit and consulting firms: a conceptual and empirical approach. *Knowl Manage Res Prac*, 10(1), 4-15.
- Kang, J., Rhee, M., & Kang, K. H. (2010). Revisiting knowledge transfer: Effects of knowledge characteristics on organizational effort for knowledge transfer. *Expert Systems with Applications*, 37(12), 8155-8160.
- Khamseh, H. M., & Jolly, D. R. (2008). Knowledge transfer in alliances: determinant factors. *Journal of Knowledge Management*, 12(1), 37-50.
- Liyanage, C., Elhag, T., Ballal, T., & Li, Q. (2009). Knowledge communication and translation – a knowledge transfer model. *Journal of Knowledge Management*, 13(3), 118-131.
- Maier, R., & Remus, U. (2003). Implementing process - oriented knowledge management strategies. *Journal of Knowledge Management*, 7(4), 62-74.
- Martinkenaite, I. (2011). Antecedents and consequences of inter-organizational knowledge transfer: Emerging themes and openings for further research. *Baltic Journal of Management*, 6(1), 53-70.
- Meier, M. (2011). Knowledge Management in Strategic Alliances: A Review of Empirical Evidence. *International Journal of Management Reviews*, 13(1), 1-23.
- Riege, A. (2007). Actions to overcome knowledge transfer barriers in MNCs. *Journal of Knowledge Management*, 11(1), 48-67.
- Roberts, N., Galluch, P. S., Dinger, M., & Grover, V. (2012). Absorptive capacity and information systems research: review, synthesis, and directions for future research. *MIS Q.*, 36(2), 625-648.
- Schulz, M., & Jobe, L. A. (2001). Codification and tacitness as knowledge management strategies: an empirical exploration. *The Journal of High Technology Management Research*, 12(1), 139-165.
- Senaratne, S., & Malewana, C. (2011). Linking Individual, Team and Organizational Learning in Construction Project Team Settings. *Architectural Engineering and Design Management*, 7(1), 50-63.
- Smeets, R., & Bosker, E. M. (2011). Leaders, laggards and technology seeking strategies. *Journal of Economic Behavior & Organization*, 80(3), 481-497.
- Sussman, S. W., & Siegal, W. S. (2003). Informational Influence in Organizations: An Integrated Approach to Knowledge Adoption. *Information Systems Research*, 14(1), 47-65.
- Szulanski, G. (2000). The Process of Knowledge Transfer: A Diachronic Analysis of Stickiness. *Organizational Behavior and Human Decision Processes*, 82(1), 9-27.

- Todorova, G., & Durisin, B. (2007). Absorptive capacity: Valuing a reconceptualization. *Academy of Management Review*, 32(3), 774-786.
- Van Wijk, R., Jansen, J. J. P., & Lyles, M. A. (2008). Inter- and Intra-Organizational Knowledge Transfer: A Meta-Analytic Review and Assessment of its Antecedents and Consequences. *Journal of Management Studies*, 45(4), 830-853.
- Wu, W.-W. (2008). Choosing knowledge management strategies by using a combined ANP and DEMATEL approach. *Expert Systems with Applications*, 35(3), 828-835.
- Yang, J. (2010). The knowledge management strategy and its effect on firm performance: A contingency analysis. *International Journal of Production Economics*, 125(2), 215-223.
- Zahra, S. A., & George, G. (2002). Absorptive Capacity: A Review, Reconceptualization, and Extension. *The Academy of Management Review*, 27(2), 185-203.

Social Information Retrieval for Online Community Question Answering Services

Jun Choi Lee¹, Yu-N Cheah², and Wai Shiang Cheah³

¹Universiti Malaysia Sarawak, Malaysia, {jclee; wscheach}@unimas.my

²Universiti Sains Malaysia, Malaysia, yncheah@usm.my

ABSTRACT

Online Community Question Answering Services is a platform that allows users to seek for answers anytime and anywhere. The services cover a large collection of unstructured knowledge and become a knowledge repository for problem solving. The answers in the services are generated by other public user. This environment creates a large collection of unstructured knowledge, which can be use as knowledge source for other intelligent processes. From the review, it is a challenge to access accurate information from the Online Community Question Answering services. This study propose a social information retrieval method to access the knowledge from the services. The proposed method query and retrieve information the online services through query expansion. Then, the retrieved information is filtered through a similarity analysis between a question with a query statement and semantic relatedness between answers and the query statement. The accuracy of the proposed approach is evaluated through human evaluation.

Keywords: Social Information Retrieval, Online Community Question Answering Services, Semantic Relatedness.

I INTRODUCTION

Online Community Question Answering Services (CQA) like Yahoo! Answers, Quora and Baidu Knows are online platforms to guide users in seeking for answers. A question is posted online. Then, people can post answers based on their expertise and personal experience. Lots of studies are conducted based on online CQA. These studies ranged from artificial intelligent to human behavior studies. However, most of these studies are conducted based on pre-collected data from online CQA data. We argue that the pre-collected CQA data is not suitable for real-life applications. This is because the pre-collected data is only a snapshot of the online CQA. Application of pre-collected data in real life application will require the pre-collected data to be updated from time-to-time. Therefore, knowledge in pre-collected data cannot represent the overall knowledge in online CQA.

On the other hand, it is a time consuming and complex process in working on pre-collected data. Besides limitation of knowledge, application of pre-collected CQA data in real-life applications also required the data to be stored in a structured storage which allows it to be query and retrieved. This is a resource consuming task as online CQA constantly receive huge amount of user generated data daily.

Social Information Retrieval (SIR) is the study to apply social media in information retrieval. The process can be conducted by either query and retrieve information from social media, or applying social profile data in performing information retrieval. In this study, a social information retrieval framework is proposed to query and retrieve relevant information from selected online community question answering service.

This study presents a Social Information Retrieval to query and retrieve relevant information from the selected online CQA. Section two explains the background and motivation of the proposed SIR, while section three provides a detailed description of the proposed SIR. The evaluation of the proposed SIR and its result are presented in the section four. The paper is concluded in Section five.

II BACKGROUND AND MOTIVATION

Information Retrieval (IR) is science to gain access and retrieve relevant information from different information sources in order to satisfy information thirst of a user. This definition is shared by Salton (1968), Baeza-Yates and Ribeiro-Neto (2010), and Bouadjenek, Hacid and Bouzeghoub (2015). Boudjenek (2013) defined SIR as “The process of leveraging social information (both social relationships and the social content), extracted from social platforms, to perform an IR task with an objective of better meeting users’ needs.” Goh and Foo (2007) introduced a platform to share knowledge through Social Information Retrieval. Bouadjenek, Hacid and Bouzeghoub (2015) reported on IR approaches and platforms for social networks. From the review, most of the studies on SIR were on expanding the IR model with social network applications. These studies provide fundamentals for involving data from social network in various stages in IR architecture.

CQA also provide opportunities in various computer science and information science research. Researches in CQA covers question classification, answer quality evaluation, experts routing, user behavior analysis and answers generations. Shtok, Dror, Maarek and Szpektor (2012) uses CQA as evaluation platform for their proposed Question Answering (QA) system. To date, most of the CQA related researches are based on question answer archives. The archives are good in evaluating the proposed models, but it has some limitations in real-life applications. The limitations include the need for a huge storage capacity to store the archives, and having not up-to-date data in the archives.

Yahoo Answers provided Application Program Interface (API) to access certain information from their online CQA repository. This service was adopted by Chen (2009) and Kai (2011) in their QA research. However, the service only available for a short period of time before it was discontinued in mid of year 2014. Therefore, there is a need to looks for an alternative to access directly the online CQA repository for the relevant third party research to forward from theoretical stage to actual implementation.

A good SIR for CQA should able to retrieve useful information from their sources. Since responses in CQA are user generated, the quality of the answers is varying. Therefore it is necessary to identify quality answers from the data retrieved from the CQA. Answer quality evaluation is a research domain in IR studies. Jeon, Croft, Lee and Park (2006) attempted to predict the quality of answers 13-nontextual features in Maximum entropy learning model from the finding, they discovered that 1/3 of the dataset from Naver.com have a quality issue, and 10% of the total dataset are identified with bad answers. Jeon, Kim and Chen (2010) extended the study using price as a factor to identify quality answers in fee-based CQAs. Harper, Raban, Rafaeli and Konstan (2008) presented the differences between quality answers in different CQAs and observed how users accept the different quality criterion. Liu et al. (2008) tried to predict the answer quality using non-contextual information. Fichman (2011) studied the quality of the answers from of different online Community QA Services. Agichtein, Castillo, Donato, Gionis and Mishne (2008) applied feature extraction technique to determine a quality of the answers given. Adamic, Zhang, Bakshy, and Ackerman (2008) explored a method to predict answer quality using question and answer provided. Answer Quality prediction study done by Shah and Pomerantz (2010) were based on the information extracted from questions, answers and user profile. Blooma, Chua and Goh (2010) also explore the methods to select best answers in CQA. Tian, Zhang and Li (2013) investigated different

features from question and answers in the CQA, www.stackoverflow.com, to measure answer quality. Their study shows that the most significant factors in determining the answers quality were the number of responses and the minimum similarities between the answers.

In the previous studies, the most effective methods to evaluate the answer quality is based on non-textual features like length of answers and user reputation. However, the actual answer quality should still base on the content of the answer.

This study aims to overcome two limitations in retrieving quality information from CQA by introducing a new SIR for CQA. In the proposed SIR, a mechanism to access the online CQA repository is proposed to overcome the limitation of using archives. This study also proposed to filter quality information from the online data using text semantic relatedness. This method aims to measure the quality of the answers or data from CQAs based on content, rather than non-contextual features.

III PROPOSED SOCIAL INFORMATION RETRIEVAL

The proposed social information retrieval for online community question answering services consists of two major components: query and accessing selected online community question answering services, and filtering useful information based on the query posted by a user.

A. Query And Access Selected Online CQA

Accessing the information from online CQA is one of the most crucial and challenging components in the proposed SIR. Most online CQAs do not have API that allows user to access the collection of question and answers in their services, therefore this is the major challenge in information retrieval for these services.

Every online CQAs have at least one web services that allows user to access the question and answers in their web portal. For example, Yahoo! Answers provides Rich Site Summary (RSS) feeds that allows user to access a snapshot of the online CQA, while other online CQA like Quora and Baidu allows user to search the content of the online CQA through their web addresses. Although these web services only provides a glimpse of information in the selected CQAs, but it is enough to function as a gateway to retrieve information from these online CQAs. Therefore, the proposed SIR exploited these web services to access and query a selected online CQAs. This task is done by applying query expansion on the RSS or web link uses to retrieve information on the selected CQAs.

The query expansion is done by placing the user query in the web service links. The results of this query expansion is a list of web links. Each link represents a dedicated webpage with a specific questions and answers from the selected online CQA. The proposed SIR then will harvest the Hyper Text Markup Language (HTML) data from each of this links using web access. These HTML data contains all the information regarding a particular questions and its answer. These information are later extracted through pattern recognition process. The pattern used in extracting question and answers information from HTML data are vary depends on the CQAs, this is because each CQA have their own web design.

The final results for this process is a list of questions and their answers that related to the query statement provided by a user. However, these information need to be further filtered to obtain useful information.

B. Filtering Relevant Information

The questions and answers extracted through the query expansion and pattern recognition in previous section are user generated information. These data consists some noises that are not important such as user conversations, emotional arguments or even advertisement spam. In this process, the proposed SIR applied text semantic relatedness measures to filter the important information related from the collected data. In the study conducted by Lee and Cheah (2015), Text semantic relatedness that used to measure the degree of relationship between two texts has reasonable accuracy in identify relevant information in online CQAs. In that study, Lee and Cheah applied a text semantic relatedness that is based on Wul & Palmer (WUP) measures (Wu & Palmer, 1994) in WordNet to identify relevant answers from Yahoo! Answers.

C. Output of Proposed SIR

The result returned by the proposed SIR Framework is a list of text or answer(s) that being filtered. However the result is in the form of answers. The content of the information is highly dependent on the query statement provided by user. The results also shows another characteristic, where the answers in the results are highly redundant. This happen because of these answers are extracted from questions that share high degree of similarity. The proposed SIR remains the high redundancy characteristic of the result for it may be useful in many application of the SIR results such as in Decision Supports System or Question Answering system.

IV IMPLEMENTING THE PROPOSED SIR ON YAHOO! ANSWERS

In the final section of this study, the proposed SIR is evaluated through an implementation of the proposed SIR. For the implementation, this study had selected

Yahoo! Answers to serve as knowledge source for the proposed SIR. Yahoo! Answers is selected for implementation in this study because it is one of the most popular and active online CQAs currently available on Internet. The study from Harper, Raban, Rafaeli and Konstan (2008) had indicated that Yahoo! Answers not only have more responses from user compare to other online CQAs, the responses in Yahoo! Answers are also higher quality compare to other online CQAs. Another crucial element for selecting Yahoo! Answers as the online CQA for the proposed SIR is because Yahoo! Answers is open question answering platform, where there is no topic limitation in posting the question.

The querying of Yahoo! Answers online repository is done through RSS query expansion. Yahoo! Answers provides Rich Site Summary (RSS) feed for user to access a snapshot of repository in Yahoo! Answers. The RSS feature also provides search function, where user can directly search the Online Yahoo! Answers repository. The social information retrieval access Yahoo! Answers repository by reconstruct the RSS feed based on the user query. The RSS feed for the reconstructed link is obtained through normal HTTP web request. The RSS feed returns from Yahoo! Answers are (Extensible Markup Language) XML that consists of questions and their Yahoo! Answers links. No answer is provided in the RSS feed.

The RSS feed only consists a numbers of questions and some basic information such as the question, the link to the question in Yahoo! Answers, the date the question is posted and some brief description regarding the question posted by the author. These information need to go through several process before it can be extracted for further use.

Each link in the RSS feed represents a dedicated webpage in Yahoo! Answers for a particular question. The raw format of the webpage (HTML) is obtained through a web request for each of the question in the RSS feed. Before extracting the information from the webpage, all HTML tags in the document is removed. The remaining text is an array of text. The answers for each question are extracted from this array of text using a text pattern rules. The text pattern rules used in extracting the information is shown in Table 1. These rules are obtained through detailed study on the text pattern exists in the Yahoo! Answers webpage. There are three type of possible answers in a page: "Best Answer", "First Answer" and "Other Answers".

Table 1. Text Pattern To Extract Information From Webpage After Removing HTML Tag

Information	Text Patterns
Best Answer	Start: After the line starts with “Best Answer:” End: before the line starts with “Source(s)” AND The third line starts with “·” and ends with “ago”
First Answer	Start: the line starts from “Oldest” End: before the line starts with “Source(s)” AND The third line starts with “·” and ends with “ago”
Other answer	Start: After the line starts with “Report Abuse” End: before the line starts with “Source(s)” AND The third line starts with “·” and ends with “ago”

All the possible answers for a question in the question and answer page are extracted for further usage. However, as mentioned in Section III, the answers collected need to be filtered to obtain relevant information regarding the query statement. And the filtering is conducted through the use of text semantic relatedness based on WUP measure in WordNet, with a threshold value of 0.6. The threshold value used to filter the answer is based on the experiment conducted by Lee and Cheah (2015). The filtering result is the final output of the proposed SIR. Figure 1.0 shows the screenshot of an implementation of the proposed SIR.



Figure 1. Screenshot Of The Implementation For The Proposed SIR

V CONCLUSION

This study presented a SIR framework to extract and filter information from a selected CQAs. The SIR queries selected CQA through web request and harvest questions and answers. Then, useful information from the question answer is obtained

through a filtering process. The filtering process uses a text semantic relatedness in order to measure relationship between a query statement and candidate answers. The final output of the SIR is a list of answers from related CQAs. These outputs can serve as information for further knowledge process. An implementation of the SIR based on Yahoo! Answers as knowledge source is developed in this study. This implementation demonstrates the capability of the proposed SIR in querying an existing online CQAs and return a set of answers that presumable relevance to the query statements.

The proposed SIR have a wide range of potential applications. It can be applied as knowledge source for various intelligent process such as decision support systems or answer generation system. The proposed SIR is also useful in studies such as event summarizer and human behavior studies.

Although the proposed SIR currently is able to retrieve relevant information from selected CQAs. The study can be furthered in various ways. One of the future enhancement for this study is to incorporate more than one social platform to retrieve information relevant to the query statement. The current implementation of the SIR is only based on Yahoo! Answers, but it had been identified that other CQAs such as Quora, and Baidu Knows is also compatible to serve as knowledge source in the proposed CQAs. Combining different CQAs in the proposed SIR will enrich the knowledge pool to obtain information. Besides CQAs, the proposed SIR framework should also expands to other social platform such as Facebook and Twitters to further enrich the content for the information retrieval process.

Besides enriching the content of the results through expand the knowledge source to various social platforms. The proposed SIR can be further enhanced by using a more comprehensive filtering process. The current filtering processes is done using a text semantic relatedness that based on WUP measure in WordNet. This semantic relatedness still possess some limitation due to the limited real-world concept knowledge in WordNet. Therefore, filtering the information in SIR using a more comprehensive filtering technique such as using Latent Semantic Analysis (LSA) will improve the quality of the information retrieved using the SIR framework.

Finally, this study only demonstrated the proposed SIR through a simple implementation. A detailed evaluation is needed to understand the performance of the proposed SIR in information retrieval.

ACKNOWLEDGMENT

This study is supported by Universiti Malaysia Sarawak (UNIMAS) and Universiti Sains Malaysia (USM).

REFERENCES

- Adamic, L. A., Zhang, J., Bakshy, E., & Ackerman, M. S. (2008). Knowledge sharing and yahoo answers: everyone knows something. In Proceedings of the 17th international conference on World Wide Web (pp. 665-674). ACM.
- Agichtein, E., Castillo, C., Donato, D., Gionis, A., & Mishne, G. (2008). Finding high-quality content in social media. In Proceedings of the 2008 International Conference on Web Search and Data Mining (pp. 183-194). ACM.
- Baeza-Yates, R., & Ribeiro-Neto, B. (1999). *Modern IR* (Vol. 463). New York: ACM press.
- Blooma, M. J., Chua, A. Y. K., & Goh, D. H. L. (2010). Selection of the best answer in CQA services. In Seventh International Conference on Information Technology: New Generations (ITNG), 2010 (pp. 534-539). IEEE.
- Budan, I. A., & Graeme, H. (2006). Evaluating WordNet-Based Measures of Semantic Distance. *Computational Linguistics*, 32(1), 13-47.
- Bouadjeneq, M. R., Hacid, H., & Bouzeghoub, M. (2015). Social Networks and IR, How Are They Converging? A Survey, a Taxonomy and an Analysis of Social IR Approaches and Platforms. *Information Systems*.
- Bouadjeneq, M. R. (2013). *Infrastructure and Algorithms for Information Retrieval Based On Social Network Analysis/Mining* (Doctoral dissertation, Versailles-Saint-Quentin-Yvelines).
- Chen, L. (2009). *Recommending best answer in a collaborative QA system*. (Master dissertation, Queensland University of Technology)
- Fichman, P. (2011). A comparative assessment of answer quality on four QA sites. *Journal of Information Science*, 37(5), 476-486.
- Goh, D., Foo, S. (2007). *Social IR Systems: Emerging Technologies and Applications for Searching the Web Effectively: Emerging Technologies and Applications for Searching the Web Effectively*. IGI Global.
- Harper, F. M., Raban, D., Rafaeli, S., & Konstan, J. A. (2008). Predictors of answer quality in online Q&A sites. In Proceedings of the SIGCHI Conference on Human Factors in Computing Systems (pp. 865-874). ACM.
- Jeon, G. Y., Kim, Y. M., & Chen, Y. (2010). Re-examining price as a predictor of answer quality in an online Q&A site. In Proceedings of the SIGCHI conference on human factors in computing systems (pp. 325-328). ACM.
- Jeon, J., Croft, W. B., Lee, J. H., & Park, S. (2006, August). A framework to predict the quality of answers with non-textual features. In Proceedings of the 29th annual international ACM SIGIR conference on Research and development in information retrieval (pp. 228-235). ACM.
- Kai, W. (2011). *Retrieving questions and answers in community-based Question Answering services* (Doctoral dissertation, National University of Singapore).
- Lee, J.C. & Cheah Y-N. (2015b). Identifying Relevant Answers in Online CQA Services. In Conference of Information Technology in Asia 2015 (CITA'15). 4th – 5th August, 2015. Kuching, Malaysia.
- Liu, Y., Li, S., Cao, Y., Lin, C. Y., Han, D., & Yu, Y. (2008). Understanding and summarizing answers in community-based QA services. In Proceedings of the 22nd International Conference on Computational Linguistics-Volume 1 (pp. 497-504). Association for Computational Linguistics.
- Salton, G. (1968). Automatic information organization and retrieval. In *Information Processing & Management*, 24(5): 513-523.
- Shah, C., & Pomerantz, J. (2010). Evaluating and predicting answer quality in community QA. In Proceedings of the 33rd international ACM SIGIR conference on Research and development in information retrieval (pp. 411-418). ACM.
- Shtok, A., Dror, G., Maarek, Y., & Szpektor, I. (2012). Learning from the past: answering new questions with past answers. In Proceedings of the 21st international conference on World Wide Web (pp. 759-768). ACM.
- Tian, Q., Zhang, P., & Li, B. (2013). Towards Predicting the Best Answers in Community-based Question-Answering Services. In ICWSM.
- Wu, Z., & Palmer, M. (1994). Verbs semantics and lexical selection. In Proceedings of the 32nd annual meeting on Association for Computational Linguistics (pp. 133-138). Association for Computational Linguistics.

Linking Community of Practices and Open Innovation Through Absorptive Capacity: A Conceptual Framework for University-Industry Collaboration

Rabiah Eladwiah Abdul Rahim, Juraifa Jais, and Nor'ashikin Ali

*Universiti Tenaga Nasional (UNITEN), Malaysia
{rabiah@uniten.edu.my, juraiifa@uniten.edu.my, shikin@uniten.edu.my}*

ABSTRACT

Across organizations, community of practice (CoP) plays an important role for knowledge creation. This informal structure assists intra-community knowledge transfer which facilitates the learning or absorption of new knowledge. However, lack of research examines the role organizational absorptive capacity in assisting CoP towards open innovation. Based on resource based view and dynamic capabilities theory, this paper proposes a conceptual framework to investigate the relationship between CoP involvement and absorptive capacity and open innovation. This framework provides a sound basis for further research to shed light on the effects of R&D CoP with regards to university industry collaboration. Contributions to research and practice are discussed.

Keywords: University-industry collaboration, absorptive capacity, resource based view, dynamic capability.

I INTRODUCTION

University-industry collaboration (UIC) has taken place around the world with the notion that university as a knowledge producer will transfer knowledge into industrial sector. Operators who have knowledge in excess with respect to the internal capacity enhancement, or whose mission is the exchange of knowledge like universities and training systems in general, give knowledge to those who need it and who have the ability to acquire and enhance it (Davenport & Prusak, 1998).

Firms are increasingly streamlined in their operations and have typically developed boundary spanning collaborations for knowledge creation (Jonsson, Holmström, & Lyytinen, 2009). This is due to the rapidly rising costs for research and development (R&D) and shortened product and technology lifecycles (Sandberg, Holmström, & Levén, 2015). The reasons for these linkages are also diverse and ranging from student practical training to production and commercialization of new products (Othman & Omar, 2012). Other forces drive this collaboration also due technological advances, the shortening of

product life cycles and changes in governmental support for universities which make companies and universities to combine their resources and efforts to remain competitive (Plewa, Korff, Baaken, & Macpherson, 2013).

For universities, this collaboration will benefit primarily in economic terms, including financial support for future research (Harman, 2001), as well as the application of basic research results to industry problems (Lee, 2000). This interaction provides immense opportunities for the utilisation such newly generated knowledge in both its teaching and research activities, if it can enhance its own learning and absorptive capacity (Sparrow, Tarkowski, Lancaster, & Mooney, 2009). However, the gaps remain in respect of the role of universities in what might be termed the new open innovation landscape (Gassmann et al., 2010).

To be innovative, knowledge must be continuously created in individual, group and across organization. community of practice (CoP) create “epistemic cultures” (Knorr Cetina, 1999) where knowledge is created and transferred across organization. Originally developed by Lave & Wenger (1991) in a study of situated learning in apprenticeships, the CoPs approach has since been used to analyse and facilitate knowledge transfer in a wide variety of inter and intra organisational environments (Amin & Roberts, 2008). A common identity among members in the networks and social structures in the network (Brown & Duguid, 2001) impacts knowledge mobility since it increases motivation to participate in interactions and willingness to share experiences (Dhanaraj & Parkhe, 2006).

There has been an increased pressure put on universities to address ideas suggested by the outside and take on board actual problems faced by the industry. In doing this, the necessity of community formed in industry has been mentioned in several studies (e.g. Giudice, Peruta, & Maggioni, 2013), but lack of studies conducted in the university contextual situation. Considerable work is still required to elucidate the roles of research communities in universities and how it interacts toward the open innovation. It also remains largely unexplored how these communities benefit from

absorptive capacity to turn knowledge derived from community into innovation. In particular, there is a lack of knowledge of the degree to which the open innovation is affected by their absorptive capacity (AC) of an organization. There are needs for theoretical development and specific studies such as the impact of certain organizational antecedents, such as structures and informal networks on AC (Volberda, Foss, & Lyles, 2010).

This study develops a conceptual framework linking Research and Development (R& D) CoP involvement and AC to open innovation capability. Specifically, this research adopts Resource Based View (RBV) and dynamic capability theory to explore how CoP involvement can contribute open innovation through AC. In the following section we first introduce the conceptual framework for investigating the interplay of CoP, AC and open innovation. The subsequent section explains the background of used theories and the propositions of this study. Next, we discuss the contributions which this work makes to research and practice.

II LITERATURE REVIEW

Striukova & Rayna (2015) classified collaboration between industry and universities into formal and informal. Formal engagements include licensing of university patents, university spin-offs, employment of graduates, collaborative R&D, copublications and mutual secondments. In contrast, activities such as meetings, jointly attended lectures and conferences, e-mail communication can be considered as informal relationships. For Schartinger, Rammer, Fischer, & Fröhlich (2002), the interactions between universities and industry can be classified according to four different categories: joint research (including joint publishing), contract research (including consulting, financing of university research assistants by firms), mobility (staff movement between universities and firms, joint supervision) and training (co-operation in education, training of firm staff at universities, lecturing by industry staff). To this respect, a large number of academics, especially those involved in applied research, use several types simultaneously (D'Este & Patel, 2007).

Meanwhile, Ankrah and Al-Tabbaa (2015) viewed UIC into two categories; i) rational process which focuses on planned resource and knowledge transfer and ii) irrational process which emphasizes on knowledge creation located within informal social interaction between the organization. Studies have shown how knowledge is created within communities (Johnson, 2010 and Kassicieh, 2010). Giudice, Peruta, & Maggioni (2013) describe CoP possesses the following elements a) members of a community learn knowledge that is embedded in the

community by participating in the community and practicing their jobs, b) firmly set by the task, culture, and history of the community, c) members belong to the community and d) the membership is fairly stable, while new members need time to learn about the community of practice and become fully participatory.

The strength of the CoPs approach is its focus on the social and practice-based interaction at the heart of the learning process (Gertner, Roberts, & Charles, 2011). Within this group, interdependent individuals are working together to develop shared identities and by having this mutual understanding facilitates knowledge transfer (Roberts, 2000). The interactions within these communities allow them to share, refine, pool and disseminate best practice for their work responsibilities (West & Lakhoni, 2008). In these communities, learning is a question of new meanings and structures emerging from common enterprise, experience, and sociability—learning by doing, and does not ensue from conscious design or recognizable rationality and cognitive frames (Cohendet & Llerena, 2003; Ancori, Bureth, & Cohendet, 2000). Brown & Paul (1991) refer to practice as the “way work is done”, where practice as a locus of learning and knowledge transfer (Gherardi, 2006).

Studying the impact of informal relation and social interaction is essential to understand innovation process in UIC as this process is rooted in the nature of knowledge creation as a socially embedded process (Ankrah and Al-Tabbaa, 2015). Innovation has been evolved from individual and internal process centric into inter-collaborative innovation. The open innovation model suggests that organisations should combine external and internal ideas and technologies as effective pathways to market when advancing and commercializing technologies (Wynarczyk et al., 2013 and Leydesdorff, 2013). Open innovation can be classified into inbound (outside-in) and outbound (inside-out). The research publication by universities acts as sources for further development by other researchers and industries which can be described as outbound (or inside-out) aspect of the Open Innovation process (Striukova & Rayna, 2015). Collaboration between university and industrial partners/organizations in the open innovation context aims to support companies and universities to share their research and development resources (knowledge, ideas, expertise, patents etc.) in order to better develop and valorize the created products and services (Perkmann et al., 2013 and Leydesdorff, 2013).

III THEORETICAL FOUNDATION

Resource-Based View

To understand the linkage between community of practices and open innovation through absorptive capacity, this study integrates the resource-based view of the firm (RBV) into the development of theoretical framework. Building on a study conducted by Wernerfelt (1984), RBV of the firm has been defined as a simple economic instrument for evaluating the firm organizational resources. The evaluation is done by examining the strengths or weaknesses of the organizational resources in determining the ability of the firm to compete with other firms in the same market or industry.

Barney (1991) stated that valuable, rare, inimitable and non-substitutable resources can be a source of greater performance, enabling the firm to achieve sustained competitive advantage. To exemplify, distinctive assets, such as patents or brands are identified contributor for firm performance. Thus, a company must ensure that a firm's resources add value, rare, and costly to imitate. If a firm can create a position by which its organizational resources are difficult for other firms to imitate and these resources are highly important from the stakeholder's perspective, the firm has managed to create an organizational competitive advantage (Alvarez & Busenitz, 2001).

Based on this theory, community of practices (CoPs) is viewed as a distinctive resources and capabilities in which the deployment of these valuable resources is prominently central for the management to increase the value of the organization (Grant, 1996). CoPs allow an effective transfer of tacit knowledge through relationships and social interaction. Even though codified or explicit knowledge can be transmitted across time and space in tangible measures such as software, operating manuals, and patents, tacit knowledge transfer could only be implemented through demonstration and learning by doing (J. Roberts, 2000). Thus, tacit knowledge has distinctive capability which makes it more difficult to transfer and imitate (Szulanski, 2003). Similarly, Grant (1996) conclude that tacit knowledge is the core of firm-specific advantage.

Dynamic Capabilities

The Resource-Based View has become a major paradigm in strategy research, offering a way of identifying unique resources and providing the basis for a new theory of the firm (Conner, 1991) and a theory of competitive advantage (Barney, 1991). However, critiques claim that RBV do not address appropriately the competitive advantages in situations that require rapid and unpredictable change

(Eisenhardt & Martin, 2000). Danneels (2002) argues that it is crucial for the RBV to have a dynamic perspective, in understanding how firms evolve over time, through their deployment and acquisition of resources. Moreover, firm's sustainability depends on the ability to renew and reconfigure if they want to survive (Zahra, Sapienza, & Davidsson, 2006).

The Dynamic Capabilities Approach which emerged in the 1990s, building the missing dynamic perspective to the RBV. The concept of dynamic capabilities provides additional insights in explaining dynamic environment (i.e. globalisation, shorter product life-cycles and rapid technological developments). Dynamic capabilities have been defined as "the capacity to renew competencies to achieve congruence with the changing business environment by adapting, integrating, and reconfiguring internal and external organizational skills, resources, and functional competencies". (Helfat et al., 2007, p. 1) stated that a dynamic capability as "the capacity of an organization to purposefully create, extend or modify its resource base".

In a dynamic and turbulent environment, knowledge is a critical resource to create value and to develop and maintain competitive benefits (Teece, Pisano, & Shuen, 1997). In line with the discussion, the concept of absorptive capacity shows enough flexibility to be applied to diverse units of analysis and in research areas such as strategic management, industrial organization, organizational learning, and originality management (Zahra & George, 2002). Absorptive capacity can be defined as the ability to identify, incorporate, change, and apply external knowledge (Cohen & Levinthal, 1990). Measures of absorptive capacity as dynamic capability are often quantitatively done (Lichtenthaler, 2009).

Similarly, this study has adopted the notion of absorptive capacity to facilitate the development of theoretical framework. Foss, Iakovleva, & Kickul, (2013) agree that the dynamic capabilities view can offer a valuable theoretical lens for investigating innovation at the organizational level. In line with the nature of innovation, dynamic capabilities are more specifically associated with change (Zahra, et al., 2006). Firms must adapt their strategies and change their valuable resources to encounter and overcome multiple challenges over time. In adapting to these changes, absorptive capacity is central for firm learning processes as it can assimilate existing internal knowledge and new knowledge. Roberts, Galluch, Dinger, & Grover (2012) state that the capacity to absorb new knowledge can be leveraged to gain a competitive advantage in the marketplace, resulting in experimentation with new alternatives and knowledge about unknown market

opportunities. Therefore, the combination of existing and new knowledge via absorptive capacity allows open innovation to happen, which further expands the markets for external exploitation of innovation.

Nevertheless, a firm's absorptive capacity is fundamentally dependent on the tacit knowledge of its members, who experience the environment, add knowledge into the firm, and transfer the knowledge in products and processes (Cohen & Levinthal, 1990). The nature of tacit knowledge limits the ability of individuals to transfer the knowledge, which in turn limits the firm's absorptive capacity. The attainment of tacit knowledge is viewed as a process of learning and socialization, where members need to share tacit knowledge to participate in collaborative partnership (Gertner, et al., 2011).

Teece, et al. (1997) found that the capability of firm to manage boundary spanning collaborations efficiently is indeed a crucial capability for a firm to integrate, build and reconfigure competences to manage volatile changing environments. Therefore, the transfer of these intangible assets in collaboration or partnership is central to sustain firm competitiveness, which requiring new conceptual frameworks for business and competitive analysis. Drawing up on both RBV and Dynamic Capabilities theories, this study develops a conceptual framework to examine how university-industry collaboration can be leveraged by linking CoPs and open innovation through absorptive capacity.

IV HYPOTHESES

A. The role of CoP in open innovation

CoP is one of the organizational forms of structure which exist including in universities. Communities of practice can be defined as groups of people who are devoted to the same practice and share similar working visions (Giudice, et al., 2013). The value of the CoPs approach lies in its focus on the interactions between community members as they engage in their everyday work practices (Drew, Joanne, & David, 2011). This epistemic community is strongly dependent on the socialization of knowledge, increasing predominance of routines, and repeated interactions, in oppose to incorporation in rules or in an organizational design (Giudice, et al., 2013).

Innovations often arise from re-combination of existing methods, components or sub-systems in novel syntheses (Arthur, 2007). Contemporary organizations increasingly leverage external knowledge sources in their innovation processes

(Chesbrough, Vanhaverbeke, & West, 2008). As innovation often emerge in unpredictable ways, and informal communication and common practices are essential for knowledge transfer, open forums and informal communication channels are key ingredients of well- functioning innovation networks (Tsai, 2001).

Intra-community interactions also offer the prospect of defining the boundaries of a given innovation community (West & Lakhoni, 2008). The interactions might be extended to inter organisational level as the deliverables of particular projects might require external sources of knowledge. Open innovation advocates argue that there are particular benefits in combining competencies from academic and industrial sources in networks of innovators (Chesbrough, 2003; Levén, Holmström, & Mathiassen, 2014). By participating in such innovation networks, universities can receive financial benefits, generate valuable research findings and contribute to economic growth (Etzkowitz & Leydesdorff, 2000 and Lind, Styhre, & Aaboen, 2013).

H1: R &D CoP involvement is positively related to open innovation

B. The mediating effect of absorptive capacity

Cohen and Levinthal's (1990) define of absorptive capacity: "a limit to the rate or quantity of scientific or technological information that firm can absorb". AC may be affected by the internal organization structure and that different divisions/units may be able to absorb different kinds of knowledge (Van den Bosch et al. 1999; Cohen and Levinthal (1990, p. 135) but also may have different capabilities for transferring that knowledge internally (Volberda, et al., 2010).

Knowledge externalization and socialization in the research group of specialists are important activities in human resources development process (Draghicia, Babanb, Gogana, & Ivascua, 2015). These activities are based on the knowledge transfer process inside and outside the research groups where open innovation could better support the knowledge creation process through the knowledge transfer processes (Volberda, et al., 2010).

We argue that absorptive capacity may mediate the relationship between R &D CoP involvement and open innovation. The experience of participating in working groups by sharing and exchanging tacit knowledge may increase the ability to acquire, assimilate, transformed and exploited knowledge

from external including industry. In turn, absorptive capacity can enhance open innovation, since the more the members can absorb knowledge from industry, the higher the chance they can create innovative solutions as results of this capability. The proposed framework is shown in Figure 1.

H2: Organizational absorptive capacity mediates the relationship between R & D CoP involvement and open innovation.

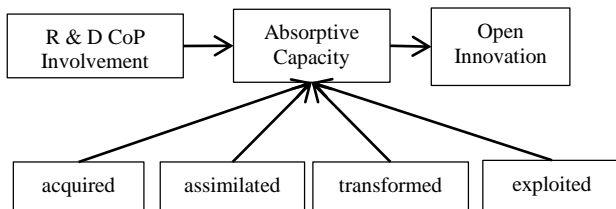

Figure 1: Conceptual Framework

V CONTRIBUTIONS

A. Contributions to Theory

First, studies on CoP within UIC have been previously conducted but how this structure lead toward open innovation through AC is not being investigated. There is insufficient evidence of theoretical development and specific studies such as the impact of CoPs and AC for open innovation capability from university context. This research contributes to the body of knowledge by formulating a conceptual framework that shows the link between CoPs and absorptive capacity for open innovation by focusing on university context.

Second, this research extends the concept of CoPs by integrating the theory of RBV and Dynamic Capabilities into the conceptual framework to examine how university-industry collaboration can be leveraged by linking CoPs and open innovation through absorptive capacity. This study considers the importance of absorptive capacity to link CoPs and open innovation between university and industry. The previous study did not incorporate the absorptive capacity for CoP approach for knowledge transfer in universities (Gertner, Roberts, and Charles, 2011). In other words, this study adds insights on how academic and industry can enhance collaboration by exploring the effect of CoPs on absorptive capacity.

B. Contributions to Practice

This research offers a number of contributions to practice. First, while CoP has been discussed widely as a strategic approach for fostering learning and

transferring knowledge, its benefits that can link university and industry have not been realized. This study provides insights to university and industry stakeholders on how the relationship of university-industry can be improved through absorptive capacity approach for CoP.

Second, the conceptual framework addresses the need for both university and industry to give attention to CoPs as a strategy for open innovation. The success of CoPs in absorptive capacity may contribute to the promotion of collaborative interaction in which the university and industry work together for open innovation.

VI CONCLUSION

The central aim of this article has been to understandings of how CoPs can be linked to open innovation through absorptive capacity approach. Our proposed framework lays the groundwork for future study to examine the relationships between CoP, absorptive capacity, and open innovation.

REFERENCES

- Ankrah, S. and Al-Tabbaa, O. (2015). Universities–industry collaboration: A systematic review. *Scandinavian Journal of Management*. 31 (3), 387-408.
- Alvarez, S. A., & Busenitz, L. W. (2001). The entrepreneurship of resource-based theory. *Journal of Management*, 27(6), 755-775.
- Amin, A., & Roberts, J. (2008). Knowing in action: beyond communities of practice. *Research Policy*, 37(2), 353-369.
- Ancori, B., Bureth, A., & Cohendet, P. (2000). The economics of knowledge: the debate about codification and tacit knowledge. *Industrial and Corporate Change*, 2, 255-287.
- Arthur, W. B. (2007). *The Nature of Technology: What it is and How it Evolves*. New York: The Free Press.
- Augier, M., & Teece, D. J. (2008). Strategy as evolution with design: The foundations of dynamic capabilities and the role of the managers in the economic system. *Organizational Studies*, 29(8-9), 1187-1208.
- Barney, J. B. (1991). Firm resources and Sustained competitive advantage. *Journal of Management*, 17(1), 99-120.
- Brown, J. S., & Duguid, P. (2001). Knowledge and organization: A social-practice perspective. *Organization Science*, 12(3), 198-213.
- Brown, J. S., & Paul, D. (1991). Organizational learning and communities of-practice: Toward a unified view of working, learning, and innovation. *Organization Science* 2(1), 40-57.
- Chesbrough, H. (2003). *Open Innovation: The New Imperative for Creating and Profiting from Technology*. Cambridge, MA.: Harvard Business School Press.
- Chesbrough, H., Vanhaverbeke, W., & West, J. (2008). *Open Innovation: Researching a New Paradigm*. Oxford: Oxford University Press.
- Cohen, W. M., & Levinthal, D. A. (1990). Absorptive Capacity: A New Perspective on Learning and Innovation. Special Issue: Technology, Organizations, and Innovation *Administrative Science Quarterly*, 35(1), 128-152.
- Cohendet, P., & Llerena, P. (2003). Routines and incentives: The role of communities in the firm. *Industrial and Corporate Change*, 12(2), 271-297.
- Conner, K. (1991). A Historical Comparison of Resource-Based Theory and Five Schools of Thought Within Industrial Organization Economics: Do We Have a New Theory of the Firm? *Journal of Management*, 17(1), 121-154.

- D'Este, P., & Patel, P. (2007). University – industry linkages in the UK: what are the factors underlying the variety of interactions with industry? *Research Policy*, 36(9), 1295-1313.
- Danneels, E. (2002). The dynamics of product innovation and Betaompetencies. *Strategic Management Journal*, 23, 1095-1121.
- Davenport, T. H., & Prusak, L. (1998). *Working knowledge: How organizations manage what they know*. USA Harvard College.
- Dhanaraj, C., & Parkhe, A. (2006). Orchestrating innovation networks. *Academy of Management Review*, 31(3), 659-669.
- Draghicia, A., Babanb, C.-F., Gogana, M.-L., & Ivascu, L.-V. (2015). A Knowledge Management Approach for The University-Industry Collaboration in Open Innovation. *Procedia Economics and Finance*, 23, 23 – 32.
- Eisenhardt, K. M., & Martin, J. A. (2000). Dynamic Capabilities: What Are They? *Strategic Management Journal* 21(10/11), 1105-1121.
- Etzkowitz, H., & Leydesdorff, L. (2000). The dynamics of innovation: from national systems and 'Mode 2' to a triple helix of university-industry-government relations. *Research Policy*, 29(2), 109-123.
- Foss, L., Iakovleva, T., & Kickul, J. (2013). *The role of microfoundations in explicating dynamic capabilities: A case study of commercializing discontinuous innovation in the Norwegian petroleum sector*, Working Paper. Retrieved from www.uis.no/getfile.php/.../FossilakovlevaKickulOfstedalSolheim.docx.
- Gertner, D., Roberts, J., & Charles, D. (2011). University-industry collaboration: a CoPs approach to KTPs. *Journal of Knowledge Management*, 15(4), 625 - 647.
- Gherardi, S. (2006). *Organizational Knowledge: The Texture of Workplace Learning*. Oxford: Blackwell Publishing.
- Giudice, M. D., Peruta, M. R. D., & Maggioni, V. (2013). Collective Knowledge and Organizational Routines within Academic Communities of Practice: An Empirical Research on Science–Entrepreneurs. *J Knowl Econ* 4, 260–278.
- Grant, R. M. (1996). Toward a knowledge-based theory of the firm. *Strategic Management Journal*, 17, 109-122.
- Harman, G. (2001). University-industry research partnerships in Australia: extent, benefits and risks. *Higher Education Research and Development*, 20(3), 245-264.
- Helfat, C. E., Finkelstein, S., Mitchell, W., Peteraf, M. A., Singh, H., Teece, D. J., et al. (2007). *Dynamic Capabilities: Understanding Strategic Change in Organizations*. Malden, MA: Blackwell Publishing.
- Johnson, S. (2010). *Where good ideas come from: The natural history of innovation*. New York, NY: Riverhead Books.
- Jonsson, K., Holmström, J., & Lyytinen, K. (2009). Turn to the material: Remote diagnostics systems and new forms of boundary-spanning. *Information and Organization*, 19(4), 233-252.
- Kassicieh, S. K. (2010). The knowledge economy and entrepreneurial activities in technology-based economic development. *Journal of Knowledge Economy*, 1, 24–47.
- Knorr Cetina, K. (1999). *Epistemic Cultures: How the Sciences Make Knowledge*. Cambridge: Harvard: University Press.
- Lave, J., & Wenger, E. (1991). *Situated Learning: Legitimate Peripheral Participation*. Cambridge: University Press.
- Lee, Y. S. (2000). The sustainability of university-industry research collaboration: an empirical assessment. *Journal of Technology Transfer*, 25(2), 111-133.
- Levén, P., Holmström, J., & Mathiassen, L. (2014). Managing research and innovation networks: evidence from a government sponsored cross-industry program. *Research Policy*, 43(1), 156-168.
- Leydesdorff, L. (2013). *Triple Helix of University-Industry-Government Relations*. New York: Springer.
- Lichtenthaler, U. (2009). Absorptive Capacity, Environmental Turbulence, and the Complementarity of Organizational Learning Processes. *Academy of Management Journal* (52(4), 822-846.
- Lind, F., Styhre, A., & Aaboen, L. (2013). Exploring university-industry collaboration in research centres. *European Journal of Innovation Management*, 16(1), 70-91.
- Mansfield, E. (1991). Academic research and industrial innovation. *Research Policy*, 20(1), 1-12.
- Othman, R., & Omar, A. F. (2012). University and industry collaboration: towards a successful and sustainable partnership. *Procedia - Social and Behavioral Sciences*, 31, 575-579.
- Perkmann, M., Tartari, V., McKelvey, M., Autio, E., Broström, A., D'Este, P., et al. (2013). Academic engagement and commercialisation: A review of the literature on university–industry relations. *Research Policy*, 42(2), 423-442.
- Roberts, J. (2000). From know-how to show-how? Questioning the role of information and communication technologies in knowledge transfer. *Technology Analysis & Strategic Management*, 12(4), 429-443.
- Roberts, N., Galluch, P. S., Dinger, M., & Grover, V. (2012). Absorptive Capacity and Information Systems Research: Review, Synthesis, and Directions for Future Research. *MIS Quarterly*, 36(2), 625-648.
- Sandberg, J., Holmström, J., & Levén, N. N. P. (2015). Balancing diversity in innovation networks. *European Journal of Innovation Management*, 18(1), 44 - 69.
- Schartinger, D., Rammer, C., Fischer, M. M., & Fröhlich, J. (2002). Knowledge interactions between universities and industry in Austria: sectorial patterns and determinants. *Research Policy*, 31(3), 303-328.
- Sparrow, J., Tarkowski, K., Lancaster, N., & Mooney, M. (2009). Evolving knowledge integration and absorptive capacity perspectives upon university-industry interaction within a university. *Education + Training*, 51(8/9), 648 - 664.
- Striukova, L., & Rayna, T. (2015). University-industry knowledge exchange. *European Journal of Innovation Management*, 18(4), 471 - 492.
- Szulanski, G. (2003). *Sticky Knowledge: Barriers to Knowing in the Firm*, London: Sage.
- Teece, D. J., Pisano, G., & Shuen, A. (1997). Dynamic capabilities and strategic management. *Management Journal*, 18(7), 509–533.
- Tsai, W. P. (2001). Knowledge transfer in intraorganizational networks: effects of network position and absorptive capacity on business unit innovation and performance. *Academy of Management Journal*, 44(5), 996-1004.
- Volberda, H. W., Foss, N. J., & Lyles, M. A. (2010). Absorbing the Concept of Absorptive Capacity: How to Realize Its Potential in the Organization Field. *Organization Science*, 21(4), 931-951.
- Wernerfelt, B. (1984). A resource-based view of the firm. *Strategic Management Journal*, 5(2), 171-180.
- West, J., & Lakhoni, K. R. (2008). Getting clear about the role of communities in open innovation. *Industry and Innovation*, 15(3), 223-231.
- Zahra, S. A., & George, G. (2002). The Net-Enabled Business Innovation Cycle and the Evolution of Dynamic Capabilities. *Information Systems Research*, 13(2), 147-150.
- Zahra, S. A., Sapienza, H. J., & Davidsson, P. (2006). Entrepreneurship and Dynamic Capabilities: A Review, Model and Research Agenda. *Journal of Management Studies*, 43(4), 917-955.

Opinion Spamming in Social Media: A Brief Systematic Review

Khairul Nizam Baharim^{1,3} and Suraya Hamid²

¹University of Malaya, Malaysia, khairulnizam@siswa.um.edu.my

²University of Malaya, Malaysia, suraya_hamid@um.edu.my

³TM Research and Development, Malaysia, khairulnizam@tmrd.com.my

ABSTRACT

Opinion spamming in social media is an activity of people giving or sharing fake reviews or irrelevant opinions to online communities. The fake reviews are not merely misguided sentiment analysis and opinion mining system, but also severely affected online communities' decision and businesses reputation. Thus, opinion spamming detection (OSD) technique is needed to enhance an opinion mining system and prevent such cases from happening to the online communities. This study was conducted using the systematic literature review (SLR) procedure to classify known opinion spam features in social media platforms, and to reveal types of social media platforms that are being addressed by OSD's researchers. The result is, we found that, spatial and temporal factors in reviewer feature type is a current issue and is important to be solved because of spammer always changing their spamming strategy. On the other hand, most of the studies leveraged n-gram character and part-of-speech approaches in a review feature type because of its significant improved OSD's accuracy. Furthermore, we found that, most of the studies focused on trading and marketing-based social media platform, in which a lack of OSD's study in other forms of social media platforms i.e. social networking and user generated content sites.

Keywords: Opinion spamming detection, Opinion spam, Review spam, Fake reviews, Social media, Survey.

I INTRODUCTION

Social media are increasingly used by online communities and organizations in their daily decision-making. Online communities usually searched for an opinion of existing product consumers before purchasing new products or services. In the mean time, organization leveraged social media information to analyze and understand customer satisfaction and demand for future products development and services improvement. Because of that, sentiment analysis and opinion mining system now become more visible and freely accessible to the online community. For example, Google Shopping² and Bing Shopping³

provide a review rating of the searched product, also a sentiment of product features related to it; where user could do a comparison across similar products before making the purchasing decision. Unfortunately, the sentiment analysis result may not accurate due to the possible existence of a fake review or an opinion spam.

In recent years, numerous high-profile fake review cases have been reported in the news media (Competition and Markets Authority, 2015; Griffith-Greene, 2014). Most of the cases involved businesses hiring people to write a fake review for them to promote their products and services. Unfortunately, it could be also to discredit their business competitors. Fake reviews in social media are thus not only harmful to consumers, but also to businesses. It would affect consumers' decision and businesses reputation severely.

Social media is a group of Internet-based applications that build on the ideological and technological foundations of Web 2.0., and that allow the creation and exchange of user generated content (Kaplan & Haenlein, 2010). Definitely categorizing various types of social media platforms is impossible, but identifying their objectives is a key to understand how the platforms were built in different niches. Dijck (2013) defines general types of social media platform as follows:

- Social networking sites (SNS) – These sites primarily promote interpersonal contact, whether between individuals or groups of people. It allows personal, professional and geographical connections exchange. Examples are Facebook, Twitter, LinkedIn, Google+, and Foursquare.
- User generated content sites (UGC) – These sites support creativity, foreground cultural activity, and promote the exchange of amateur or professional content. Well-known UGC sites are YouTube, Blogger, WordPress, and Wikipedia.
- Trading and marketing sites (TMS) – These sites principally aim at exchanging products or selling them. TMS usually contain product reviews by the consumers. Amazon and eBay come to mind as notable examples.

² <https://www.google.com/shopping>

³ <http://www.bing.com>

- Play and games sites (PGS) – These sites provide online gamers for interaction. Popular games such as a FarmVille, CityVille, The Sims Social, allow online users to communicate and exchange games feature.

However, there were no exact boundaries separating the social media platforms (Dijck, 2013). For example, SNS and TMS sites could also have creative content generated by users i.e. UGC. Thus, in this study, we scoped our review of OSD in social media for particular SNS, UGC and TMS platforms.

The contribution of this study is as follows:

- It has discovered and confirmed type of social media that are being addressed by OSD’s researchers; where most of OSD’s study were focused on TMS category and lack of OSD’s study in other forms of social media platform category i.e. SNS, UGC.
- It has revealed and tabulates type of OSD features in social media platform reported by the researchers. This findings complement with the latest OSD’s survey in (Heydari et al., 2015). The latest opinion spam features being studied were related to reviewer behavior feature and spatial-temporal factors.

The remainder of this work is structured as follows: In section II, we describe our review methodology and present the result and discussion in section III. In section IV, we conclude this study and propose an avenue of future work.

II METHOD

The SLR procedure (Kitchenham, 2004; Kitchenham et al., 2009) was first published in software engineering domain. Lately, it has been used widely in various software related domains such as information systems, computer networks, and mobile application. Hence, this study used SLR procedure to review the state-of-the-art in opinion spam detection research, particularly in social media platforms.

A. Research Questions

The research questions that addressed by this study were:

- RQ1. What type of social media platforms were being addressed by OSD’s researchers?
 RQ2. What types of opinion spam features in social media were being used by OSD’s researchers?

With respect to RQ1, opinion spam problem was first formulated by Jindal & Liu (2007) in the context of product reviews in Amazon platform, which is a type of TMS. Further comprehensive opinion spam analysis continued in (Jindal & Liu, 2008). Since then, OSD are mostly studied in the context of online

reviews and not much study has been done in the contexts of other forms (e.g. forum discussions, blogs, microblogs) of social media (Liu, 2015). To address RQ1, we identified OSD’s study published each year, the quality of journal/conferences that published them and scope of the study or dataset that are being used.

With respect to RQ2, Heydari et al. (2015) highlighted the issue of extracting the most effective and efficient OSD’s features reported in literatures. To address RQ2, we identified empirical OSD’s literature in social media, then captured and classified the reported OSD’s features.

B. Research Questions

The search process was a manual search using two most important free citation-based academic search engines i.e. Google Scholar⁴ and Microsoft Academic⁵. The search date range was set between 2007 and 2016, as the leading article by Jindal & Liu (2007) was published after Oct 31st, 2007.

The search keywords grown during the search process as depicted in Figure 1. It started by using well-known relevant keywords (we called it “seed keywords”) extracted from (Jindal & Liu, 2008) article as follow: “opinion spam”, “review spam”, “fake reviews”. A manual search was performed then using OR/AND Boolean operations. For example, the search command is: “opinion spam” OR “review spam” OR “fake reviews”. The article was selected by the researcher based on its relevant title, keywords, and abstract. New relevant keywords found in the selected article were used in the next round of search until no new result appeared.

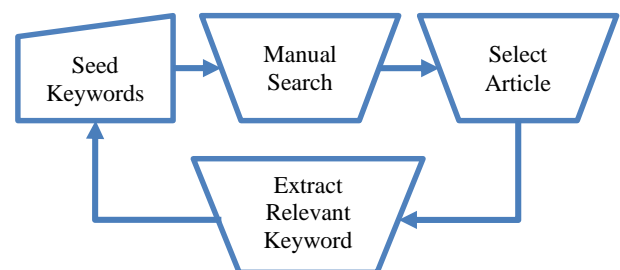

Figure 1. Keywords Development in the Search Process

The selected articles from the search process were then filtered by its quality. Relevant data were collected and analyzed to answer the research questions. The following sections detailed the process after the articles were selected.

⁴ <https://scholar.google.com/>

⁵ <https://academic.microsoft.com/>

C. Quality assessment

Articles on the following topics were excluded:

- Non-related article based on its title, keywords or abstract (not related with a problem of opinion spam in social media).
- Duplicate articles of the same study (when several articles of a study exist in different journals, the most complete version of the study was included in the review).
- Non-empirical studies (because we wanted to extract used OSD's features).
- Informal empirical studies (no defined methodology, dataset, and finding result).

D. Data collection

The data extracted from each selected article were:

- Authors.
- Article's year and keywords.
- The source (journal or conference).
- Other indexed source e.g. Web Of Science (WoS).

- Form of social media or dataset.
- OSD's features.

E. Data analysis

The data was tabulated to show:

- Literatures quality.
- Type of social media platforms (addressing RQ1).
- Classification of OSD's features (addressing RQ2).

III RESULTS & DISCUSSION

Due to space limitations, we only tabulate most significant articles based on their citation and organization reputation. The list of searched articles depicted in Table 1 for literature quality assessment. The "Selected Article" column in Table 1 indicates the articles that we have used to produce results in Table 2 for addressing RQ1, Table 3, Table 4, and Table 5 for addressing RQ2.

Table 1. Literatures Quality Assessment

Author(s)	Date	Source	Main Indexed Sources	Duplicate with Article	Methodology	Data set	Empirical Result	Selected Article
(Jindal & Liu, 2007)	2007	Conf. ICDM	WoS, IEEE	-	Y	Y	Y	N
(Jindal & Liu, 2008)	2008	Conf. WSDM	ACM	(Jindal & Liu, 2007)	Y	Y	Y	Y
(Lim, Nguyen, Jindal, Liu, & Lauw, 2010)	2010	Conf. CIKM	ACM	-	Y	Y	Y	Y
(Jindal, Morgan, & Liu, 2010)	2010	Conf. CIKM	ACM	-	Y	Y	Y	Y
(F. Li, Huang, Yang, & Zhu, 2011)	2011	Conf. IJCAI	ACM	-	Y	Y	Y	Y
(Ott, Choi, Cardie, & Hancock, 2011)	2011	Meeting ACL	ACM	-	Y	Y	Y	Y
(Wang, Xie, Liu, & Yu, 2011)	2011	Conf. ICDM	IEEE	-	Y	Y	Y	Y
(Arjun Mukherjee, Liu, & Glance, 2012)	2012	Conf. WWW	ACM	-	Y	Y	Y	Y
(Fei et al., 2013)	2013	Conf. ICWSM	ACM	-	Y	Y	Y	Y
(H. Li, Liu, Mukherjee, & Shao, 2014)	2014	Journal	WoS	-	Y	Y	Y	Y
(Banerjee & Chua, 2014)	2014	Conf. SAI	WoS, IEEE	-	Y	Y	Y	Y
(H. Li, Chen, Mukherjee, Liu, & Shao, 2015)	2015	Conf. ICWSM	AAAI	-	Y	Y	Y	Y
(KC & Murkherjee, 2016)	2016	Conf. WWW	ACM	-	Y	Y	Y	Y

Our findings in Table 2 shows that most of the OSD's studies were related to online review sites, particularly in TMS-based social media platforms. It confirmed the highlighted issue in RQ1. The social media platforms that are being addressed were: Amazon,

Epinions, Dianping, TripAdvisor, and ResellerRatings.

The main obstacle in OSD study was to find or build gold-standard opinion spam dataset in order to evaluate OSD's technique in those platforms. H. Li et

al. (2015) seems had a large-scale labeled fake reviews dataset, but the data was private due to confidential agreement with Dianping. The only available small-size public dataset⁶ for OSD modeling was created by (Ott, Cardie, & Hancock, 2012), particularly for TripAdvisor platform.

Table 2. OSD by Social Media Category and Platform

Social Media Category	Platform/ Dataset	Author(s)
Trading & marketing sites (TMS)	Amazon	(Fei et al., 2013; Jindal & Liu, 2008; Jindal et al., 2010; Lim et al., 2010; Arjun Mukherjee et al., 2012)
	Epinions	(F. Li et al., 2011)
	TripAdvisor	(Banerjee & Chua, 2014; Ott et al., 2011)
	ResellerRatings	(Wang et al., 2011)
	Dianping	(H. Li, Chen, et al., 2015; H. Li et al., 2014)
	Yelp	(KC & Murkherjee, 2016)

In the context of product reviews, there were three main types of reviews (Jindal & Liu, 2007, 2008):

- Type 1 (untruthful opinion) – It is a false opinion to lead the readers to positive or negative sentiment of the product.
- Type 2 (reviews on brand only) – Such reviews did not comment the product itself; instead emphasize the seller, organization or business.
- Type 3 (non-reviews) – Such reviews did not contain opinions, thus did not serve the purpose of reviews. It can be categorized into two main sub-categories: (1) Advertisements and (2) Other type of non-reviews such as question-and-answer communication between seller and reviewer.

Jindal & Liu (2007, 2008) considers duplicate and near-duplicate reviews as Type 1 reviews, which is one of opinion spamming factors that could be used for building OSD's model. Later in OSD's study, there were various complex opinion spamming scenarios and features identified by OSD's researchers.

We used general type of OSD's features category that were defined in (Jindal & Liu, 2007, 2008) to classify the collected OSD's features. Those were: (1) Review Features, (2) Reviewer Features, and (3) Product Features. However, later studies focused on reviewer behavior, in which we classified it as a kind of Reviewer Features in Table 4. Arjun Mukherjee et al. (2012) categorized spamming reviewer behavior indicators as: (1) Group Spam Behavior, and (2) Individual Spam Behavior. Rich reviewer behavior indicator further experimented in (H. Li, Chen, et al.,

2015) were related to spatial and temporal features. The experimental result shown, by combining all kind of features that were behavior (A Mukherjee, Venkataraman, Liu, & Glance, 2013), linguistic (Ott et al., 2011) and spatial-temporal increased the accuracy of OSD's technique (H. Li, Chen, et al., 2015).

We classified type of OSD's features depicted in Table 3, Table 4, and Table 5 to answer the RQ2. In review features, n-gram characters and part-of-speech approaches were mostly used because of its significant improved OSD's accuracy. As discussed earlier, spatial and temporal factors in reviewer features are the current issues that are being explored by OSD's researchers. It is important because of professional opinion spammers always change their strategy in order to gain business profit.

Table 3. Review Features-based OSD

Feature(s)	Author(s)
Metadata – e.g. total-feedback, helpful feedback, title-length, body-length, review-position	(Jindal & Liu, 2008; F. Li et al., 2011)
Textual – e.g. capital, numeral, personal-pronouns, question, exclamation	(Jindal & Liu, 2008; F. Li et al., 2011; Arjun Mukherjee et al., 2012)
Similarity - e.g. similar-with-other-reviews	(F. Li et al., 2011)
Rating – e.g. review-rating, deviation-average, feature-rating, after-good/bad review?	(Jindal & Liu, 2008; Jindal et al., 2010; F. Li et al., 2011)
Sentiment analysis	(Jindal & Liu, 2008; KC & Murkherjee, 2016; F. Li et al., 2011)
N-gram characters	(Jindal & Liu, 2008; KC & Murkherjee, 2016; F. Li et al., 2011; H. Li, Chen, et al., 2015; H. Li et al., 2014; Ott et al., 2011)
Part-of-speech	(Banerjee & Chua, 2014; H. Li, Mukherjee, Liu, Kornfield, & Emery, 2015; Arjun Mukherjee et al., 2012; Ott et al., 2011)
Psycholinguistic – using Linguistic Inquiry and Word Count (LIWC).	(Banerjee & Chua, 2014; H. Li, Mukherjee, et al., 2015; Ott et al., 2011)
Readability – e.g. complexity, reading-difficulty	(Banerjee & Chua, 2014)
Honesty – store-reliability, agreement-with other-reviewer-within-time-window.	(Wang et al., 2011)

⁶ http://myleott.com/op_spam/

Table 4. Reviewer Features-based OSD

Feature(s)	Author(s)
Review – e.g. wrote-first-review, the-only reviewer, multi-review-single-product, multi-review-group-product, review-diff-brand, burst-review-ratio, similar-review-diff-product, review-on-weekend, posted-via-PC,	(Fei et al., 2013; Jindal & Liu, 2008; F. Li et al., 2011; H. Li, Mukherjee, et al., 2015; Lim et al., 2010; Arjun Mukherjee et al., 2012)
Rating – e.g. avg/stddev-rating-given, good/bad-rating-given, deviation-avg-rating, weight-early-rating, diff-brand-diff rating,	(Fei et al., 2013; Jindal & Liu, 2008; F. Li et al., 2011; H. Li, Mukherjee, et al., 2015; Lim et al., 2010; Arjun Mukherjee et al., 2012)
Profile – e.g. reviewer-id, real-name?, homepage?, self-description, rank-popularity, registered-user,	(Jindal et al., 2010; F. Li et al., 2011; H. Li, Mukherjee, et al., 2015)
Trustworthy – e.g. reviewer-trust-reviewer, high-honest-review-score, amazon-verified-purchase,	(Fei et al., 2013; F. Li et al., 2011; Wang et al., 2011)
Group behavior – e.g. group-time-window, group-deviation, group-content-similar, group-early-time, group-size, group total-product,	(Arjun Mukherjee et al., 2012)
Location – e.g. user-distance, avg-travel-speed, avg-distance, unique-IP, unique-cookies, unique-cities-writing-review,	(H. Li, Mukherjee, et al., 2015)

Table 5. Product Features-based OSD

Feature(s)	Author(s)
Price	(Jindal & Liu, 2008)
Sales – e.g. sales-rank	(Jindal & Liu, 2008)
Rating – e.g. product-rating, avg/stddev product-rating	(Jindal & Liu, 2008; F. Li et al., 2011)
Profile – e.g. product-id, brand-id	(Jindal et al., 2010)
Review – e.g. brand/product-mentioned, review similar with product features, first product-review?	(F. Li et al., 2011)
Reliability – e.g. trustworthy-reviewer-say good	(Wang et al., 2011)

IV CONCLUSION

Opinion spamming in social media is a critical problem that needs to be solved because of its impact towards consumers and businesses decision. In this study, we tabulated a list of significant OSD articles from 2007 till early 2016 to show the known opinion spam features in OSD and social media that are being addressed. The findings confirmed that most of the OSD studies are in online reviews platform or TMS social media category. The latest opinion spam feature being studied is related to reviewer behavior and spatial-temporal features. Our future works are to

explore OSD in social networking sites and user generated content platforms. We will perform empirical studies to discover the most effective and efficient OSD features.

REFERENCES

- Banerjee, S., & Chua, A. Y. K. (2014). Applauses in hotel reviews: Genuine or deceptive? *Proceedings of 2014 Science and Information Conference, SAI 2014*, 938–942. <http://doi.org/10.1109/SAI.2014.6918299>
- Competition and Markets Authority. (2015). *CMA acts to maintain trust in online reviews and endorsements*. Retrieved from <https://www.gov.uk/government/news/cma-acts-to-maintain-trust-in-online-reviews-and-endorsements>
- Dijk, J. Van. (2013). *The culture of connectivity: A critical history of social media*. New York: Oxford University Press.
- Fei, G., Mukherjee, A., Liu, B., Hsu, M., Castellanos, M., & Ghosh, R. (2013). Exploiting Burstiness in Reviews for Review Spammer Detection. *Proceedings of the Seventh International AAAI Conference on Weblogs and Social Media*, 175–184.
- Griffith-Greene, M. (2014, November 6). Fake online reviews: 4 ways companies can deceive you. *CBC News*. Retrieved from <http://www.cbc.ca/news/business/fake-online-reviews-4-ways-companies-can-deceive-you-1.2825080>
- Heydari, A., Tavakoli, M. A., Salim, N., & Heydari, Z. (2015). Detection of review spam: A survey. *Expert Systems with Applications*, 42(7), 3634–3642. <http://doi.org/10.1016/j.eswa.2014.12.029>
- Jindal, N., & Liu, B. (2007). Analyzing and detecting review spam. *Proceedings - IEEE International Conference on Data Mining, ICDM*, 547–552. <http://doi.org/10.1109/ICDM.2007.68>
- Jindal, N., & Liu, B. (2008). Opinion spam and analysis. *Proceedings of the International Conference on Web Search and Web Data Mining WSDM 08*, 219. <http://doi.org/10.1145/1341531.1341560>
- Jindal, N., Morgan, S., & Liu, B. (2010). Finding Unusual Review Patterns Using Unexpected Rules. In *Proceedings of the 19th ACM international conference on Information and knowledge management* (pp. 1549–1552). <http://doi.org/10.1145/1871437.1871669>
- Kaplan, A. M., & Haenlein, M. (2010). Users of the world, unite! The challenges and opportunities of Social Media. *Business Horizons*, 53(1), 59–68.
- KC, S., & Mukherjee, A. (2016). On the Temporal Dynamics of Opinion Spamming: Case Studies on Yelp. In *International World Wide Web Conference Committee (IW3C2)* (pp. 369–379). <http://doi.org/10.1145/2872427.2883087>
- Kitchenham, B. (2004). *Procedures for Performing Systematic Reviews. Joint Technical Report*.
- Kitchenham, B., Pearl Brereton, O., Budgen, D., Turner, M., Bailey, J., & Linkman, S. (2009). Systematic literature reviews in software engineering - A systematic literature review. *Information and Software Technology*, 51(1), 7–15. <http://doi.org/10.1016/j.infsof.2008.09.009>
- Li, F., Huang, M., Yang, Y., & Zhu, X. (2011). Learning to identify review spam. In *International Joint Conference on Artificial Intelligence (IJCAI)* (pp. 2488–2493). <http://doi.org/10.5591/978-1-57735-516-8/IJCAI11-414>
- Li, H., Chen, Z., Mukherjee, A., Liu, B., & Shao, J. (2015). Analyzing and Detecting Opinion Spam on a Large-scale Dataset via Temporal and Spatial Patterns. *Proceedings of Ninth International AAAI Conference on Web and Social Media*, (MAY), 634–637.
- Li, H., Liu, B., Mukherjee, A., & Shao, J. (2014). Spotting Fake Reviews using Positive-Unlabeled Learning. *Computación Y Sistemas*, 18(3), 2–10. <http://doi.org/https://dx.doi.org/10.13053/CyS-18-3-2035>
- Li, H., Mukherjee, A., Liu, B., Kornfield, R., & Emery, S. (2015). Detecting Campaign Promoters on Twitter Using Markov Random Fields. *Proceedings - IEEE International Conference on Data Mining, ICDM*, 290–299. <http://doi.org/10.1109/ICDM.2014.59>
- Lim, E.-P., Nguyen, V.-A., Jindal, N., Liu, B., & Lauw, H. W. (2010).

- Detecting Product Review Spammers using Rating Behaviors. *Proceedings of the 19th ACM International Conference on Information and Knowledge Management*, 939–948. <http://doi.org/10.1145/1871437.1871557>
- Liu, B. (2015). *Sentiment Analysis: Mining Opinions, Sentiments and Emotions*. New York: Cambridge University Press.
- Mukherjee, A., Liu, B., & Glance, N. (2012). Spotting fake reviewer groups in consumer reviews. *Proceeding WWW '12 Proceedings of the 21st International Conference on World Wide Web*, 191–200. <http://doi.org/10.1145/2187836.2187863>
- Mukherjee, A., Venkataraman, V., Liu, B., & Glance, N. (2013). What yelp fake review filter might be doing? In *ICWSM*.
- Ott, M., Cardie, C., & Hancock, J. (2012). Estimating the prevalence of deception in online review communities. *Proceedings of the 21st International Conference on World Wide Web - WWW '12*, 201–210. <http://doi.org/10.1145/2187836.2187864>
- Ott, M., Choi, Y., Cardie, C., & Hancock, J. T. (2011). Finding Deceptive Opinion Spam by Any Stretch of the Imagination. *Proceedings of the 49th Annual Meeting of the Association for Computational Linguistics*, 11.
- Wang, G., Xie, S., Liu, B., & Yu, P. S. (2011). Review graph based online store review spammer detection. *Proceedings - IEEE International Conference on Data Mining, ICDM*, 1242–1247. <http://doi.org/10.1109/ICDM.2011.124>

Student's Perception to Learning of Innovative Skills through Multi-Dimensional Visualization System: Reliability and Validity Tests of some Measurements

Ishola D. Muraina, and Huda Haji Ibrahim

Universiti Utara Malaysia, Malaysia {ishod;huda753@uum.edu.my}

ABSTRACT

Learning has been described as the process of obtaining new knowledge, skills and habits, and can be subjective to the individual preparedness to learn, especially in the context of gaining the innovative skills. Knowing the perception of student's towards learning of innovative skills would assist the management and teachers on the appropriate approach for teaching. However, there has been less or no research that focuses on bringing the perception of students towards the learning of innovative skills into reality prior to the commencement of teaching. Therefore, a Multi Dimensional Visualization system is proposed in this research to reveal the level of perception of students towards learning of innovative skills in university set up by adapted Expectation Confirmation Model. An experiment was conducted by engaging 200 undergraduate students within the university campus so as to measure their level of perception towards learning of innovative skills using the proposed system. A measurement model analytical technique from the perspective of Partial Least Square of Structural Equation Model was used to confirm the reliability and validity of the proposed system, while the result shows high accuracy. This research gives useful hints for the university's management by obtaining the perception of student prior to learning of innovative skills.

Keywords: Multi Dimensional Visualization, Learning Perception, Innovative Skills, Expectation Confirmation Model.

I INTRODUCTION

Innovation in teaching and learning has been viewed as an approach of changing past orientation of knowledge sharing and moving towards acquisition of skills in a centralized way, thus increasing the self practicing of student's acquired knowledge (Smith, 2012 & Gosling, 2009). Teaching of innovation as part of the curriculum in the institution of higher learning does not only broad the student's reasoning but also allowing them being creative in the field of their endeavour (Molenaar et al., 2011; Cachia et al., 2010). This implies that students require acquisition of innovative skills which should be part of their

curriculum in order to be independent in practicing and be employability in life.

Learning of innovative skills by the students of institution of higher learning should be encouraged in order to instill mind of being creative, self-learning, learning to learn, build competence and confidence among students (Molenaar et al., 2011). Thus, innovative skill could be liken to approach of forming a creative learning and process of effecting new techniques, tools and contents that add to the value of learners and their creative potential (Cachia et al., 2010; Zavertrnik et al., 2010). In the aspect of teaching, many institutions of higher learning have introduced different innovations in their teaching towards complimentary of achieving innovative skills among the students, such as online learning, forum and virtual classroom (Smith, 2012; Pundak & Rozner, 2008). On the other hands, the perception of students towards learning or acquiring knowledge about innovative skills is the issue of concerned which can lead to its success or failure.

Previous studies have portrays variation in the attitude of students towards acquiring innovative skills while learning (Parai et al., 2015; Jwayyed et al., 2011). This may due to the influence of different learning style on the students' assimilations (Parai et al., 2015). In other words, perceptions of students towards learning of innovative skills may become difficult to study since it is intrinsic in nature, thus require its expression in reality form so as to identify the appropriate learning style for individual students. Studies have shown that student's perceptions have been conducted on the pedagogical content knowledge on self-efficacy in self regulating learning (Criu & Marian, 2014); e-learning in blended environment (Bauk, 2015); dimensional comparisons of the learning environment (Arens & Moller, 2016). However, there has not been study to the knowledge of researcher that focuses on bringing the perception of students towards learning of innovative skills into reality prior to the teaching. Knowing the perceptions of students on the learning of innovative skills would assist in using the appropriate teaching style to enhance their academic achievement (Wei et al., 2011).

Visualization of one's cognitive mood portrays the implementation of processed data to arrive at a

specified level of understanding (Yusoff & Salim, 2015). On the other hands, visualization of individual's perception on a subject matter may be referred to as the interpretation of different dimensions of modeled factors (Lukeneder, 2012). Therefore, visualization of one's intention can be achieved through a computerized system that is capable of interpreting modeled dimensions. Hence, this research proposes a Multi Dimensional Visualization (MDV) system towards bringing the student's perception to learning of innovative skills into reality. This will assist the teacher in choosing the appropriate teaching approach while teaching.

II RELATED WORKS

Possession of innovative skills subjects individual into presentation of work and its content differently and effectively (Brzycki & Dudt, 2005; Cheung & Huang, 2005). The study of Brzycki and Dudt (2005) argued that learning of innovative skills provides avenue and mechanism for developing new method and technology for problem solving. Thus, innovative skills provide opportunity for the learners to gain more information on the holistic cycle of the new techniques. On the other hands, innovative skills ensure self development and encourage creativity on the learners (Wolff, 2008). Hence, learners should be active in seeking for the innovative skills so as to become authentic and experienced learners.

Researchers have stressed that success of introducing the innovative skills as part of the curriculum in higher institutions could be on its relevant to the concept of the respective institutions (Smith, 2012; Heilesen & Josephsen, 2008; Ozdemir & Abrevaya, 2007). This may have direct effects on the perception of some students towards learning of innovative skills. Previous study has stressed that perceptions of students in the institutions of higher learning have been captured through the use of questionnaires, focus groups and interviews (Parai et al., 2015). However, each of the known approach has one or the other pros and cons depend on the ground of usage and the researchers. Moreover, a technological based mode of teaching has been described as the new method of imparting knowledge (Sanz et al., 2000; Zahorian et al., 2000). Thus, using a technological approach in visualizing the perception of students towards learning of innovative skills cannot be overestimated (Parai et al., 2015). Hence, this study proposes a system to assist in bringing the perception of students towards learning of innovative skills into reality.

III THEORETICAL FRAMEWORK

This study bases its theoretical foundation on the Expectation Confirmation Theory (ECT) due to its ability to ascertain the continuity or discontinuity of individual on the use of technology (Muraina et al., 2016; Muraina et al., 2015; Ham et al., 2012; Hwang et al., 2011; Chiu & Wang, 2008; Bhattacharjee, 2001). The ECT portrays that users of technology possess initial expectation prior to assessment of a service. Thus, users bound to compare the perceived performance vis-a-vis original expectation which leads to continue or discontinue. In the context of this study, visualization of student's perception on the innovative skills could be obtained by capturing their belief on the expected benefit of acquiring innovative skills. Besides, it requires focusing on the agreement between their expectation and the main performance of the innovative skills, thus inducing their feelings about acquiring the skills. Hence, the ECT would assist in obtaining the perceptions of individual students towards learning of innovative skills. The adapted model of the ECT together with the conceptual definitions of their constructs is shown in Figure 1, research model and Table 1 respectively.

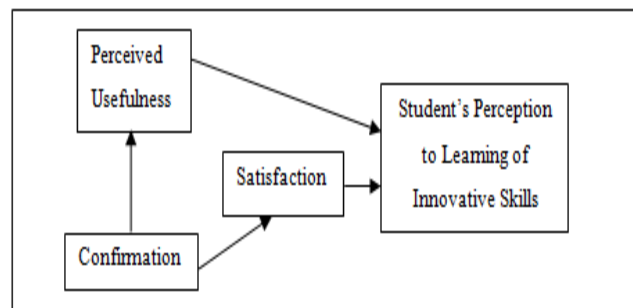

Figure 1. Research Model

Table 1. Conceptual Definition

Constructs	Definitions
Perceived usefulness	Student's perception of the expected benefits of learning of innovative skills.
Confirmation	Student's perception of agreement between their expectation and the learning of innovative skills.
Satisfaction	Student's feelings prior to learning of innovative skills
Learning perception of innovative skills	Student's change or reaction in knowledge or behavior as a result of experience gained in learning innovative skills.

IV RESEARCH METHODOLOGY

A. Designing of Multi Dimensional Visualization System

Visualization of the student's perception towards learning of innovative skills is achieved in this

research through the MDV system. The MDV system was designed using C# programming language. Besides, computation of the system is based on the research model in Figure 1 by taking its constructs; perceived usefulness, confirmation, satisfaction and learning perception into consideration. The system is designed to estimate the level of perception of students towards learning of innovative skills and visualize their status as shown in Figure 2 and 3. Thus, the MDV system categorizes the perception level as low perception ($\leq 60\%$), moderately perception (61% – 70%) and highly perception ($> 70\%$).



Figure 2. Login Page

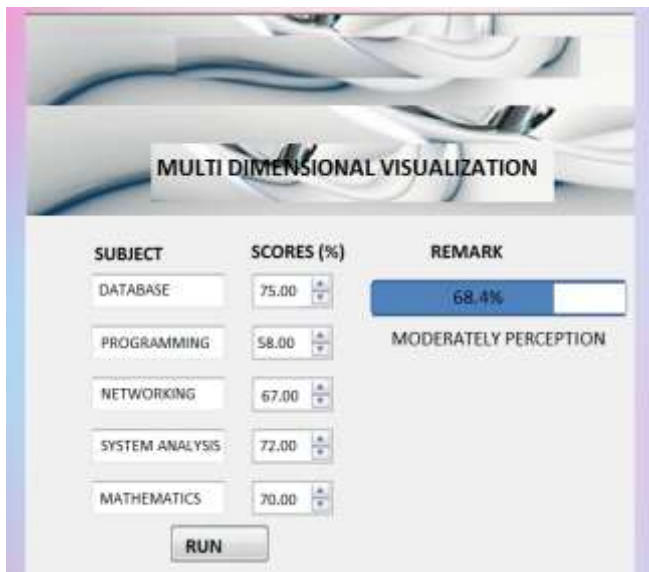

Figure 3. Perception's Measuring Page

B. Experimental Procedure and Data Collection

The experimental procedure in this research was achieved by asking the students to install the MDV application on their respective Personal Computer

(PC), running on Windows 10 operating system. Therefore, we ensure that all the students' PCs have only one Google chrome browser and Java Script to achieve homogenous of the systems and avoid bias in the participants' results. The instructions were given to the selected undergraduate students to register with the proposed MDV system and answer the required questions which based on their previous performance in the selected courses. The MDV system runs the participant's responses and visualizes their perceptions level as shown in Figure 3.

Meanwhile, selection of participants for the experiment was done through simple random sampling from the undergraduate students in Universiti Utara Malaysia. The total number of 200 undergraduate's students was selected through fishbowl technique of simple random sampling towards testing of functionality of the MDV system. Moreover, 200 survey questionnaires were distributed to all the students that took part in the experiment to measure their perception on the functionality of the proposed system. The designed questionnaire comprises of the measurement items for the research model's constructs as shown in Table 2.

Table 2. Constructs and their Measurement Items

Constructs	Measurement items
Perceived usefulness	<ul style="list-style-type: none"> i. Using MDV system helps determining my performance towards learning of innovative skills. ii. Using MDV system helps determine my level of effectiveness in the classroom towards learning of innovative skills. iii. Using MDV system assist in determining my capacity in solving the class's tasks towards learning of innovative skills. iv. Using MDV system is useful in revealing my academic performance with respect to learning of innovative skills.
Confirmation	<ul style="list-style-type: none"> i. I have better experience while using MDV system towards my perception in learning innovative skills. ii. The service level provided by MDV system was better than my expectation towards my perception in learning of innovative skill.
Satisfaction	<ul style="list-style-type: none"> i. I was satisfied with overall experience gained while using MDV system towards determining my perception to learn innovative skills. ii. I was very pleased with overall experience gained while using MDV system towards knowing my perception to learn innovative skills. iii. I was very contented with overall experience had while using MDV

	<p>system towards knowing my perception to learn innovative skills.</p> <p>iv. I was absolutely delighted with overall experience gained while using MDV system towards knowing my perception to learn innovative skills.</p>
Learning perception of innovative skills	<p>i. I intend to use MDV system to reveal my perception to learning of innovative skills.</p> <p>ii. I intend to use MDV system than use any alternative to reveal my perception to learning of innovative skills.</p> <p>iii. I oppose using MDV system to reveal my perception to learning of innovative skills.</p> <p>iv. I intend to use alternative method than MDV system towards revealing my perception to learning of innovative skills.</p>

IV DATA ANALYSIS AND RESULTS

The reliability and validity of the MDV system were achieved by observing the measurement model of the research model in Figure 1, since it is the basis for development of the MDV system. This was done using the Partial Least Square (PLS) of Structural Equation Model (SEM). The measurement model of the research model in Figure 1 takes care of the convergent validity based on the Fornell Lacker criteria that all the items must be significant at 0.05 with their loading factors greater than 0.7, while the Average Variance Extracted (AVE) should exceed 0.5. The obtained results which confirmed the reliability of the MDV system revealed that loaded factors were above 0.7, while the results of AVE exceeded 0.5 as shown in Table 3 and Table 4 which confirmed discriminant validity.

Table 3. Composite Reliability and AVE for the Factors

Construct	Composite Reliability	Cronbach Alpha	AVE	R ²
Perceived usefulness	0.8341	0.7234	0.5453	-
Confirmation	0.8967	0.7652	0.6342	-
Satisfaction	0.8852	0.8324	0.6236	-
Learning Perception of Innovative Skills	0.7935	0.7634	0.5735	0.621

Although, Cronbach alpha as been described as a conservative way of measuring the internal

consistency (reliability) of the indicators of the correlated variable (Hair et al., 2014). Yet, the result of the reliability of the correlated variables used in designing the MDV system were high, ranges from 0.7234 to 0.8324, as shown in Table 3. This implies that any output generated from the MDV system should be reliable as a result of the high Cronbach alpha which is higher than the threshold of 0.7. Moreover, the obtained values in the composite reliability column in Table 3 with high internal consistency values indicate that input into the MDV system do not interfere with each other, thus capable of classifying the perception of students towards learning of innovative skills into different groups (low perception, moderate perception and high perception). Hence, the MDV system is reliable in taking care of visualizing the perception of students to learning of innovative skills.

Table 4. Discriminant Validity (Fornel Lacker Criteria)

Variables	Perceived usefulness	Confirmation	Satisfaction	Learning Perception of Innovative Skills
Perceived usefulness	0.7435			
Confirmation	0.6342	0.8534		
Satisfaction	0.5873	0.6453	0.7641	
Learning Perception of Innovative Skills	0.5673	0.7453	0.6432	0.7564

The discriminant validity as shown in Table 4 represents the extent at which a construct is distinct from another constructs by view of empirical explanation. This confirms that the constructs used in the MDV system do not repeat what the other construct stands for. In other words, all the four constructs in the MDV system measure different constituents of perceptions of the students towards learning of innovative skills. Thus it assists the MDV system to avoid interference of one construct on another constructs while categorizing and visualizing (low perception, moderate perception and high perception) the perceptions of the students towards learning of innovative skills. Hence, the empirically analysis through the Fornel Lacker Criteria of discriminant validity as shown in Table 4 represents the validity of MDV system.

V DISCUSSION AND CONCLUSION

The main objective of developing the MDV system is to bring the perception of students towards learning of

innovative skills into reality and more interpretable to the audience. The use of the presented MDV system eases determining the level of perceptions of students to learning of innovative skills in the institution of higher learning. Besides, the reliability and validity of the presented MDV system is high as shown in Tables 3 and 4 respectively. This shows that any value and the categorized perception generated by the MDV system would be reliable to interpret the cognitive mood of individual towards the use of the system. On the other hands, this research will be extended in future by increasing the attributes of participants for generalization of the research.

REFERENCES

- Arens, A.K., & Moller, J. (2016). Dimensional Comparisons in Students' Perceptions of the Learning Environment. *Learning and Instruction*, Vol. 42, pp. 22-30.
- Bauk, S.I. (2015). Assessing Students' Perception of E-Learning in Blended Environment: An Experimental Study. *Procedia Social and Behavioural Sciences*, Vol. 191, pp. 323-329.
- Bhattacharjee, A. (2001). Understanding Information Systems Continuance: An Expectation-Confirmation Model. *MIS Quarterly*, Vol. 25, No. 3, pp. 351-370.
- Brzycki, D., & Dudt, K. (2005). Overcoming Barriers to Technology Use in Teacher Preparation Program. *Journal of Technology and Teacher Education*, Vol. 13, No. 4, pp. 619-641.
- Cachia, R., Ferrari, A., Ala-Mukta, K., & Punie, Y. (2010). Creative Learning and Innovative Teaching: Final Report on the Study on Creativity and Innovation in Education in the EU Member States. *Luxembourg: Publications office of the European Union*.
- Cheung, W., & Huang, W. (2005). Proposing a Framework to Assess Internet Usage in University Education: An Empirical Investigation from a Student's Perspective. *British Journal of Educational Technology*, Vol. 36, No. 2, pp. 237-237.
- Chiu, C.M., & Wang, E.T.G. (2008). Understanding Web-Based Learning Continuance Intention: The Role of Subjective Task Value. *Information & Management*, Vol. 45, No. 3, pp. 194-201.
- Criu, R., & Marian, A. (2014). The Influence of Students' Perception of Pedagogical Content Knowledge on Self-Efficacy in Self-Regulating Learning in Training of Future Teachers. *Procedia Social and Behavioural Sciences*, Vol. 142, pp. 673-678.
- Gosling, D. (2009). Educational Development in the UK: A Complex and Contradictory Reality. *International Journal for Academic Development*, Vol. 14, No. 1, pp. 5-18.
- Hair, J.F., Hult, G.T.M., Ringle, C.M., & Sarstedt, M. (2014). *A Primer on Partial Least Squares Structural Equation Modeling (PLS-SEM)*. Sage Publications, Inc., USA, pp. 101-104.
- Ham, J., Park, J., Lee, J.N., & Moon, J.Y. (2012). Understanding Continuous Use of Virtual Communities: A Comparison of Four Theoretical Perspectives. *IEEE Computer Society*, pp. 753-762.
- Heilesen, S.B., & Josephsen, J. (2008). E-learning: Between Augmentation and Disruption? *Computers & Education*, Vol. 50, No. 2, pp. 525-534.
- Hwang, I.H., Yu, C.C., Tsai, S.J., Lin, C.H. (2011). An Empirical Study of the Factors Affecting Continuous Usage Intention of Double Reinforcement Interactive E-Portfolio Learning System. *IEEE Explore*, pp. 246-249.
- Jwayyed, S., Stiffler, K.A., Wilber, S.T., Southern, A., Weigand, J., & Bare, R. (2011). Technology-Assisted Education in Graduate Medical Education: A Review of the Literature. *International Journal of Emergency Medicine*, Vol. 4, p. 51.
- Lukeneder, A. (2012). Computed 3D Visualisation of An Extinct Cephalopod using Computer Tomographs. *Computers and Geosciences*, Vol. 45, pp. 68-74.
- Molenaar, I., Van Boxtel, C.A.M., & Slegers, P.J.C. (2011). Metacognitive Scaffolding in an Innovative Learning Arrangement. *Instr Sci. Springer*, Vol. 39, pp. 785-803.
- Muraina, I.D., Osman, W.R.S., Ahmad, A., Ibrahim, H., & Yusof, S.A. (2016). Modeling the Behavioural Intention of Broadband Technology Usage among Teenagers: Application of UTAUT Model. *Asian Journal of Information Technology*, Vol. 15, Issue 3, pp. 593-601.
- Muraina, I.D., Osman, W.R.S., & Ahmad, A. (2015). The Roles of Some Antecedents of Broadband User Behavioural Intention among Students in the Rural Areas through PLS-SEM. *American Journal of Applied Sciences*, Vol. 12, No. 11, pp. 820-829.
- Ozdemir, Z.D., & Abrevaya, J. (2007). Adoption of Technology-Mediated Distance Education: A Longitudinal Analysis. *Information and Management*, Vol. 44, No. 5, pp. 467-479.
- Parai, M., Shenoy, P., & Loh, K.Y. (2015). Students' Perception of Technology-Assisted Learning in Undergraduate Medical Education-A Survey. *The Social Science Journal*, Vol. 52, pp. 78-82.
- Pundak, D., & Rozner, S. (2008). Empowering Engineering College Staff to Adopt Active Learning

- Methods. *Journal of Science Education and Technology*, Vol. 17, No. 2, pp. 152–163.
- Sanz, S., Iskander, M.F., & Yu, L. (2000). Development of an Interactive Multimedia Module on Antenna Theory and Design. *Computer Applications in Engineering Education*, Vol. 8, No. 1, pp. 11–17.
- Smith, K. (2012). Lessons Learnt From Literature on the Diffusion of Innovative Learning and Teaching Practices in Higher Education. *Innovations in Education and Teaching International*, Vol. 49, No. 2, pp. 173-182.
- Wei, C.Y., Hoo, Y.H., & See, J. (2011). Relationship between Learning Styles and Content Based Academic Achievement among Tertiary Level Students. *Enhancing Learning: Teaching and Learning Conference*.
- Wolff, W.I. (2008). A Chimera of Sorts?: Rethinking Educational Technology Grant Programs, Courseware Innovation, and the Language of Educational Change. *Computers & Education*, Vol. 51, No. 3, pp. 1184–1197.
- Yusoff, N.M., & Salim, S.S. (2015). A Systematic Review of Shared Visualisation to Achieve Common Ground. *Journal of Visual Languages and Computing*, Vol. 28, pp. 83-9.
- Zahorian, S., Swart, W., Lakdawala, V., Leathrum, J., & Gonzales, O. (2000). A Modular Approach to Using Computer Technology for Education and Training. *International Journal of Computer Integrated Manufacturing*, Vol 13, No. 3, pp. 286–297.
- Zavertnik, J.E., Huff, T.A., & Munro, C.L. (2010). Innovative Approach to Teaching Communication Skills to Nursing Students. *Journal of Nursing Education*, Vol. 49, No. 2, pp. 65.

Knowledge Management In Indonesia Small And Medium Enterprises (SMEs): A Conceptual Model

Ardian Adhiatma and Olivia Fachrunnisa

Sultan Agung Islamic University (UNISSULA), Indonesia, {ardian; olivia.fachrunnisa@unissula.ac.id}

ABSTRACT

In this global market, the growth of Small to Medium Enterprises (SMEs) has improving. Thus, the competition among SMEs becomes more rapid which requires them to put more efforts in maintaining their existence and development. Facing this issue, organizations should turn their entrepreneurial orientation from money oriented to innovation oriented. To innovate better, HRs in an organization should be knowledgeable hence the organization has to advance its knowledge management. This research aims to examine the relationship of entrepreneurial orientation, knowledge management, total quality management, and organizational innovation performance. Theoretical model drawn from literature review/survey is presented in this study. Therefore, this research can be one of new literatures which study about this issue from new frame. Thus, future research is presented in this study.

Keywords: entrepreneurial orientation, knowledge management, total quality management, organizational innovation performance

I INTRODUCTION

In this century, the economic system direction in the world has changed into entrepreneurial economy (Audretsch & Thurik, 2004). The competitive environment gets wider as a result of globalization challenge and all organizations attempt to reconstruct strategies to achieve sustainable competitive advantage (Madhoushi, Mehrdad, 2011). From the last three decades it is found that there is relationship pattern between knowledge management practice and innovation coming from SME (Thompson & Leyden, 1983).

Word (2012) explains that there is structural change of work and organization which more focus on managing and maximizing the working output. A dynamic working environment is used by organization to take knowledge and change the competitive advantage suited to the environment (Yeo, 2005). Organizational culture will always support organizational learning and bring benefit for the organization by generating knowledge (Nonaka et al, 2008). As globalization increases challenge in organization, the organization should focus on speed and innovation for customers (Ruona & Gibson, 2004).

Therefore, surviving in industrial world, SMEs should have strategy focus, such as knowledge-based economy in order to maintain competitive advantage (Ruona & Gibson, 2004). A knowledge based enterprise use knowledge for enhancing its performance through information management which enable the enterprise to share, manage, reuse, and transfer knowledge as well as provide knowledge for other parties in the organization (Lin, Hsiu-Fen, 2007; Takeuchi & Nonaka, 2004; Uhlener & Van Santen 2007). Thus, an appropriate knowledge management is essential for the development of SMEs. On the other side, O'Dell and Grayson (1998) state that Total Quality Management (TQM) is a long-term key motor of competitive advantage in the world. TQM will bring benefit to an organization, such as in decreasing cost, improving service, and satisfying customers, if it is well-applied (Oakland & Porter, 2004; Longest, Rakich, & Darr, 2000).

In the attempt competitive advantage, performance and value of an organization need to be improved, hence causing organizational innovation (Gloet & Terziovski, 2004; Singh & Smith 2004). Innovation also takes big role in maintaining sustainable competitive advantage through performance enhancement, problem-solving, and value improvement (Prajogo, Power, & Sohol, 2004). Brock (2003) finds that innovation will improve the effectiveness and competitiveness through autonomy, where innovation directly impact on performance (West & Iansiti, 2003; Brockman & Morgan, 2003) and entrepreneurial action has direct effect on innovation process (Ireland & Webb, 2007). Mei and Nie (2007) and Chung-Jen, et al (2010) see a positive and significant relationship between knowledge management and organizational innovation. Corso, et al (2002) emphasizes that knowledge management will increase the research interest about innovation ability in the organization. Thus, SMEs need to witness its organization support the innovation (Prince & Brecht, 2000). However, what happens in the reality is low research contribution in understanding the knowledge management issues related to SMEs innovation (Sparrow, 2001).

Aside of the relation between knowledge management and organizational innovation, there are other aspects influencing innovation, such as culture and Total Quality Management (TQM). Hung, et al (2010) finds that TQM significantly related to innovation and organizational changes. Pinho (2008) also states that TQM has given positive contribution

to management practice, so the organization performance improved.

There are many aspects which impact on the organization performance, hence it is important for an organization to understand the relationship among them. This research aims to analyze the relationship among entrepreneurial orientation, knowledge management, total quality management, and organizational innovation performance.

II LITERATURE REVIEW

Entrepreneurial orientation has become one of the most established and researched constructs in the entrepreneurship literature (Wales, William, 2013, 2015; Covin, Jeffrey; Lumpkin, 2011). Entrepreneurial orientation has been shown to be a strong predictor of organization performance with a meta-analysis of past research indicating a correlation in magnitude roughly equivalent to the prescription of taking sleeping pills and getting better sleep (Rauch, Andreas; Wiklund, Johan; Lumpkin, G.T.; Frese, Michael, 2009). Entrepreneurial orientation has most frequently been assessed using nine-item psychometric instrument developed by (Jeff Covin and Dennis Slevin; Wales, William, 2015). Thus, this research uses the five dimension of entrepreneurial orientation, such as autonomy, innovativeness, proactiveness, aggressiveness and risk-taking in order to realize the product and process innovation. Strategic orientation entrepreneurial orientation enhances organization performance as well as overall variance in it. Increased variance occurs as result of the observation that many entrepreneurial actions ultimately fail to generate an economic return thereby contributing to an increased distribution of firm performance outcomes (Wiklund, Johan; Shepherd, Dean, 2011; Wales, William; Patel, Pankaj; Lumpkin, 2013). As a core organizational strategic orientation, the breadth and depth research on entrepreneurial orientation continues to expand as the concept is adopted to understand the effects of being entrepreneurial across an increasing number of research contexts (Wales, William; Gupta, Vishal; Mousa, Fariss, 2013). In order to increase sustainable competitive advantage and improve organization performance, SMEs need to manage knowledge in the organization. Beckman (1999) states that knowledge can be defined as belief, experience, as well as information. The combination of those three aspects will provide an illustration to evaluate and merge new experience and information (Davenport & Prusak, 1998).

Knowledge management then refers to systematic and integrative process which helps the organization to find, decide, manage, distribute, and transfer substantial information, knowledge, experience, and ability needed in certain activities, such as problem-solving, dynamic learning, strategic planning, and decision-taking. The maximization of knowledge management bring benefit to people in the

organization as every member of organization will gain and share more knowledge, so it will increase their performance and ability to innovate. Liao, et al (2003) state that innovation mobility and innovation process effectiveness are influenced by knowledge management (covers knowledge adding and sharing). Nonaka and Takeuchi (1995) and Argote, et al (2003) explain that the effectiveness of knowledge management become mediation of communication and exchange in the innovation process. It will improve the organization performance through new ability.

Proposition 1: Entrepreneurial orientation is positively related to knowledge management

The concept of innovation involves research and enhancement of technology, idea, process, service, and management in the organization. Then, it will result on the enhancement of organization operational performance (Singh & Smith, 2004). In general, innovation has many contributions on organization performance, and then it analyzes how an organization can adapt with market changes, competition, and technology. Kanji (1996) explains that there are six types of innovation, such as product, process, implication, system, competition and horizontal. However, it is based on the resource and competency of the organization.

Gopalakrishnan and Bierly (2001) divide innovation into six types, such as administrative, technical, product, process, radical, and incremental. According to Boone (2000), the result of product innovation is the new-coming product in the market. This also covers restoration in product-making process or change in product-making method. The result of process innovation covers company cost reduction. Innovation may cover the improvement of product or service, innovation process, and organization ability. It is important that these three elements are linked together and are compatible. Innovation can be an important way for SMEs to succeed and remain running the business, so the SMEs will be able to compete in dynamic environment.

Proposition 2: Entrepreneurial orientation is positively related to organizational innovation performance

Proposition 3: Knowledge management is positively related to organizational innovation performance

Total Quality Management (TQM) is one of quality-based approaches (Sun 2000). TQM contribute to improve the organization performance and achieve sustainable competitive advantage. This concept is based on loyalty as it will bring long-term benefit for the organization. Thus, the organization need to instill the quality of value by putting the consumer and producer elements together supported by top management, continuous enhancement commitment, quality assurance, training and culture change in the

organization (Crosby, 1996 ; Deming, 1996; Basterfield, 2003).

Besides, Antony et al. (2002) and Maguad (2006) state that the concept of total quality management is directed to the achievement of long-term organizational success through continuous enhancement, hence it will be beyond the customers' expectation.

Proposition 4: Knowledge management is positively related to total quality management

Proposition 5: Total quality management is positively related to organizational innovation performance

III PROPOSED MODEL

Entrepreneurial Orientation (EO) is a firm-level strategic orientation which captures organization's strategy-making practices, managerial philosophies, and organizational behaviors that are natural (Anderson, Brian; Covin, Jeffrey; Slevin, Dennis, 2009). In this research, entrepreneurial orientation comprises five dimensions, such as autonomy, innovativeness, pro-activeness, aggressiveness and risk-taking.

Knowledge Management (KM) refers to a systematic and integrative process of coordinating organization activities, such as acquiring, creating, storing, sharing, diffusing, developing, and spreading knowledge to pursuit major organizational goals (Rastogi, 2000). In this research, knowledge management comprises three dimensions, such as acquisition, sharing and application.

Total Quality Management (TQM) is recognized as a key to achieve long-term sustainable competitive advantage around the world (Dean & Bowen, 1994; Prajogo & Sohol, 2001; Oakland). In this research, Total Quality Management (TQM) involves five dimensions, such as top management support, employee involvement, continuous improvement, customer focus and database decision.

Organizational Innovation Performance (OIP) plays a critical role in maintaining sustainable competitive advantage (Prajogo, Power, & Sohol, 2004; Tushman & Nadler, 1986). In this research, organizational innovation performance includes two dimensions, such as product innovation performance and process innovation performance.

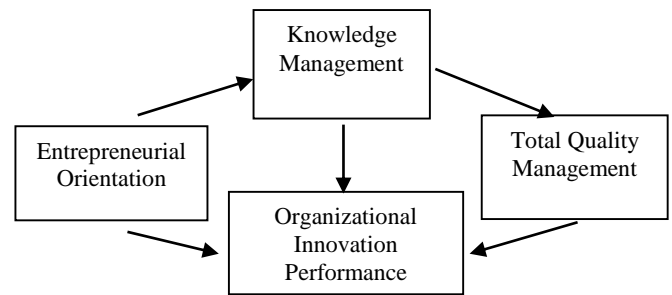

Figure 7. The Proposed Model of the relationship among entrepreneurial orientation, knowledge management, total quality management, and organizational innovation performance

IV DIRECTION FOR FUTURE RESEARCH

In economic growth, there are two main aspects can be used by SMEs to improve organizational performance, such as knowledge management and organizational innovation. However, there are other aspects presumed as having influence on organizational performance, such as total quality management, and organizational innovation performance. This study is kind of initial step to analyze theoretical structure on the relationship among variables towards organizational performance improvement, especially on knowledge management, which then will open the study gate for further researches. Empirical proof should be presented in the future to show the influence of the aspects on organizational performance of SMEs. Therefore, the study should demonstrate the significance of the relationship among variables, including how the aspects are able to impact the SMEs performance. Then, future research questions arise as follows:

- How is the relationship among all variables in influencing organizational performance?
- How the relationship between knowledge management and organizational performance differs from other aspects?
- How will organizational performance improve if it is impacted by all aspects at once?

V CONCLUSION

This study proposes a model that show the relationship of (1) entrepreneurial orientation which comprises autonomy, innovativeness, pro-activeness, aggressiveness and risk-taking, (2) knowledge management which involves acquisition, sharing and application, (3) total quality management which includes top management support, employee involvement, continuous improvement, customer focus and database decision, and (4) organizational

innovation performance which comprises product innovation performance and process innovation performance. By analyzing all variables, this study aims to be able to improve a conceptual model on the relationship of knowledge management and organizational performance.

REFERENCES

- Anderson, Brian S. ; Covin, Jeffrey G. and Slevin, Dennis P., Understanding the relationship between entrepreneurial orientation and strategic learning capability: an empirical investigation, Strategic Management Society. Published by John Wiley & Sons, Ltd. Strategic Entrepreneurship Journal Volume 3, Issue 3, pages 218–240, 2009
- Antony, J., K. Leung, G. Knowles, and S. Gosh 2002. Critical success factors of TQM implementation in Hong Kong industries. International Journal of Quality & Reliability Management 19, no.5: 551-566.
- Argote, L., B. McEvily and R. Reagans, 2003. Managing knowledge in organizations: An integrative framework and review of emerging themes. Manage. Sci., 49(4): 571
- Audretsch, D., & Thurik, R. 2004. A model of entrepreneurial economy. International Journal of Entrepreneurship Education, 2(2):143-166.
- Audretsch, D., & Thurik, R. 2000. Capitalism and democracy in the 21st century: from the managed to the entrepreneurial economy. Journal of Evolutionary Economy, 10:17
- Basterfield, D. 2003. Quality control. 7th ed. New York: Prentice-Hall.
- Beckman, T.J. 1999. The current state of knowledge management. In J. Liebowitz (Ed.), Knowledge Management Handbook. Boca Raton, FL: CRC Press.
- Boone, J. 2000. Competitive pressure: The effects on investments in product and process innovation. RAND Journal of Economics 31, no. 3: 549-569.
- Brockman, B.K. and R.M. Morgan, 2003. The role of existing knowledge in new product innovativeness and performance. Decision Sci., 34: 385-420.
- Brock, D.M., 2003. Autonomy of individuals and organizations: Towards a strategy research agenda. Inter. J. Bus; Econ., 2(1): 57-73.
- Chung-Jen, C., Jing-Wen, H., Yung-Chang, H. (2010). Knowledge management and innovativeness: The role of organizational climate and structure. International Journal of Manpower, 31(8), 848-870.
- Corso, M., Martini, A., Pellegrini, L., & Paolucci, E. 2002. Technological and organizational tools for knowledge management: in search of configurations. Small Business Economics, 0:1- 12.
- Covin, Jeffrey; Lumpkin, G. T. (2011). "Entrepreneurial Orientation Theory and Research: Reflections on a Needed Construct". Entrepreneurship: Theory & Practice 35 (5): 855–872.
- Crosby, P.B. 1996. Quality is still free: Making quality certain in uncertain times. New York: McGraw-Hill.
- Davenport, T.H. and L. Prusak. 1998. Working knowledge: How organizations manage what they know. Boston, MA: Harvard Business School Press.
- Dean, J.W. and D.E. Bowen. 1994. Management theory and total quality: Improving research and practice through theory development. Academy of Management Review 19, no. 3:392-418.
- Deming, W.E. (1986). Out of the crisis. Cambridge, MA: MIT press.
- Gloet, M. and M. Terziovski 2004. Exploring the relationship between knowledge management practices and innovation performance. Journal of Manufacturing Technology Management 15, no.5: 402-409.
- Gopalakrishnan, S. and P. Bierly. 2001. Analyzing innovation adoption using knowledge based approach. Journal of Engineering and Technology Management 18, no. 2: 107-118.
- Hung, R. Y. Y., Lien, B. Y. H., Fang, S. C., McLean, G. N. (2010). Knowledge as a facilitator for enhancing innovation performance through total quality management. Total Quality Management, 21(4), 425-438.
- Ireland, R.D. and J.W. Webb. 2007. A cross disciplinary exploration of entrepreneurship research. J. Manage., 33(6): 891-927.
- Kanji, G.K. 1996. Can total quality management help innovation? Total Quality Management 7, no. 1: 3-9.
- Liao, J., Welsch, H., & Stoica, M. 2003. Organizational absorptive capacity and responsiveness: an empirical investigation of growth-oriented SMEs. Entrepreneurship Theory and Practice, fall: 63-85.
- Lin, Hsiu-Fen, Knowledge sharing and firm innovation capability : an empirical study, International Journal of Manpower, vol 28 no. 3/4 315-332, 2007
- Longest, Jr. B., J. Rakich, and K. Darr 2000. Managing health services organizations and systems. 4th ed. MD: Health Professions Press.
- Madhoushi, Mehrdad, Sadati Abdolrahim, Delavari Hamidraza, Mehdivand Mohsen and Mihandrost Ramin, Entrepreneurial Orientation and innovation Performance : The Mediating Role of Knowledge Management, Asiam Journal of Business Management 3(4):310-316, 2011.
- Maguad, B.A. 2006. The modern quality movement: Origins, development and trends. Total Quality Management 17, no. 2: 179-203.
- Mei, S., Nie, M. (2007). Relationship between knowledge sharing, knowledge characteristics, absorptive capacity and innovation: An empirical study of Wuhan optoelectronic cluster. The Business Review, 7(2), 154-161.
- Nonaka, I. and H. Takeuchi, 1995. The Knowledge-Creating Company. Oxford University Press, New York.
- Nonaka, I., Toyama, R., Hirata, T. and Ebrary, I. (2008), Managing Flow: A Process Theory of the Knowledge-based Firm, Palgrave Macmillan, NY.
- O'Dell, C. and C.J. Grayson. 1998. If only we knew what we know: Identification and transfer of internal best practices. New York: The Free Press.
- Oakland, J. and L. Porter. 2004. Quality 21. Quality World 30, no. 1: 10-14.
- Pinho, J. C. (2008). TQM and performance in small medium enterprises: The mediating effect of customer orientation and innovation. International journal of quality & reliability management, 25(3), 256-275.
- Prajogo, D.I. and A.S. Sohol. 2001. The relationship between TQM practices and innovation performance: A literature review and research framework. Technovation, The international Journal of Technological Innovation and Entrepreneurship 21, no. 9: 539-558.
- Prajogo, D.I., D.J. Power, and A.S. Sohol. 2004. The role of trading partner relationships in determining innovation performance: An empirical examination. European Journal of Innovation Management 7, no. 3: 178-186.
- Prince, Y.M., & Becht, J.A. 2000. MKB-Kenniscirkels, waar zoekt het MKB welke kennis EIM, Zoetermeer.
- Rastogi, P.N. 2000. Knowledge management and intellectual capital-The new virtuous reality of competitiveness. Human Systems Management 19, no. 1: 39-49.
- Rauch, Andreas; Wiklund, Johan; Lumpkin, G. T.; Frese, Michael (2009). "Entrepreneurial Orientation and Business Performance: An Assessment of Past Research and Suggestions for the Future". Entrepreneurship: Theory & Practice 33 (3): 761–787.
- Ruona, W.E. and Gibson, S.K. (2004), "The making of twenty-first-century HR: an analysis of the convergence of HRM, HRD, and OD", Human Resource Management, Vol. 43 No. 1, pp. 49-66.
- Singh, P.J. and A. Smith. 2004. Relationship between TQM an innovation: An empirical study. Journal of Manufacturing Technology Management 15 5: 394-401.
- Sparrow, J. 2001. Knowledge management in small firms. Knowledge and Process Management, 8 (1):3-16.
- Sun, H. 2000. Total quality management, ISO 9000 certification and performance improvement. International Journal of Quality & Reliability Management 17, no. 2: 168-179.
- Takeuchi, H., & Nonaka, I. 2004. Hitotsubashi on Knowledge Management, Singapore: John Wiley and Sons.
- Thompson, J.H., & Leyden, D.R. 1983. The United States of America. In Storey, D.J. (Eds.), The small firm – an international survey: 7-45. London: Croom Helm.
- Uhlener L.M. & Van Santen J. 2007. Organization context and knowledge management in SMEs: A study of Dutch technology-based Firms', in H. Landstrom, M. Raffa, and L. landoli (Eds.), Entrepreneurship, Competitiveness and Local Development

- Frontiers in European Research, Cheltenham, UK: Edward Elgar Publishing: 170-199.
- Wales, William; Gupta, Vishal; Mousa, Fariss (2013). "Empirical research on entrepreneurial orientation: An assessment and suggestions for future research". *International Small Business Journal* 31 (4): 357–383.
- Wales, William; Patel, Pankaj; Lumpkin, G. T. (2013). "In Pursuit of Greatness: Ceo Narcissism, Entrepreneurial Orientation, and Firm Performance Variance". *Journal of Management Studies* 50 (6): 1041–1069.
- Wales, William (2015). "Entrepreneurial orientation: A review and synthesis of promising research directions". *International Small Business Journal*
- West, J. and M. Iansiti, 2003. Experience, experimentation and the accumulation of knowledge: The evolution of R&D in the semiconductor industry. *Res. Policy*, 32: 809-826.
- Wiklund, Johan; Shepherd, Dean (2011). "Where to from Here? Eo-as Experimentation Failure, and Distribution of Outcomes". *Entrepreneurship: Theory & Practice* 35 (5): 925–946.
- Word, J. (2012), "Engaging work as a calling: examining the link between spirituality and job involvement", *Journal of Management, Spirituality and Religion*, Vol. 9 No. 2, 147-166.
- Yeo, R.K. (2005), "Revisiting the roots of learning organization: a synthesis of the learning organization literature", *The Learning Organization*, Vol. 12 No. 4, 368-382.

Knowledge Audit on the Implementation of Knowledge Management in Public Sector Research Institute in Malaysia: A Case Study

Harlisa Zulkifli¹, Mohammad Fikry Abdullah² and Mardhiah Ibrahim³

National Hydraulic Research Institute of Malaysia (NAHRIM), {harlisa¹, fikry²}@nahrin.gov.my, mardhiah.iat³@gmail.com

ABSTRACT

Knowledge Management (KM) is a strategic initiative essential for any organisation to succeed. This paper discusses the evaluation of KM initiatives in the Malaysian Government Research Institute by performing knowledge audit. The evaluation was conducted to test the effectiveness of the current KM initiatives adopted by National Hydraulic Research Institute of Malaysia (NAHRIM) and to identify shortcomings that exist for the purpose of improvement. The methodology of the study involved an initial study by operating the company visit and literature on four other organisations that have successfully implemented the KM as a benchmark. Then, a survey was carried out to the employees of NAHRIM to identify their awareness; and the interviews were conducted among Top Management Officers of NAHRIM to gather their opinions towards current KM initiatives. In the final section of this paper, recommendations are presented as the results of the evaluation that has been carried out.

Keywords: Knowledge Audit, Survey, Interview, Government, Knowledge Management.

I INTRODUCTION

Knowledge Management (KM) has generated demanding interest in organisations, academic institutions as well as public sector. KM implementation is a need to ensure the sustainability and agility of the growth and successfulness of an organisation, especially for an organisation that relies on intellectual property and knowledge workers. KM is aimed to leverage organisation's knowledge assets or often referred as intellectual property (employee's core competencies, skills and experiences, organisational workflow and business processes) by providing a systematic way of capturing and making use of employee's expertise towards organisation's survival, sustainability and continuity.

Research Institute (RI) has high dependencies towards creation, usage, storing and sharing of knowledge. It requires KM to ensure sustainability of its business continuity and agility. Implementation of KM in Public Sector Research Institution is therefore, inline with the initiative by Malaysian Administrative Modernisation and Management Planning Unit, through its Knowledge Management

Blueprint (MAMPU, 2011). RI uses gigantic amount of knowledge in the form of tacit (knowledge in an individual's mind) and explicit (documented knowledge) (NAHRIM, 2014). Knowledge that exists in RI normally tacit, generated from the skills and experiences gained by Researchers through day to day job tasks basis, studies, research and development (R&D) activities, investigations, observations, experiments and so forth, especially Researchers who work in a cross-functional and cross-field environment (NAHRIM, 2014). Knowledge that they acquire, specifically by Subject Matter Experts (SME) is beneficial to organisation. Hence, effective KM and sharing is crucial to RI to fully utilise knowledge gained.

Evaluation of KM implementation in an organisation is a need to see whether it meets the expectation, requires improvement, could be an indicator for other exploration and etc. We perform knowledge audit (KA) in National Hydraulic Research Institute of Malaysia (NAHRIM) to evaluate the successfulness and weaknesses of KM implemented in this organisation. Most of the KM initiatives in some organisations ended up with failure or doesn't meet the objective merely because the organisations were not ready (Choy, Lee, & Cheung, 2004).

II PREVIOUS WORK

The implementation of KM in NAHRIM started in 2007 under the 9th Malaysia Development Plan (RMK9) through the development of an online repository system namely Pusat Gedung Hidraulik Kebangsaan (GEDUNG). Initially, GEDUNG is used for storing, retrieving, accessing and sharing of technical reports, publications and internal documents of NAHRIM. The project was initiated and coordinated by Information Technology Division of NAHRIM. Technical report overviewed by (Mohammad Fikry, Juhaimi, & Salmah, 2008) briefly explained the needs of a focal repository system to integrate the documents management related to the knowledge of hydraulic, water and the environment of water research, owned by NAHRIM and the stakeholders. From information system, GEDUNG evolved into a knowledge sharing system through the enhancement of modules and functionalities, as well as Standard Operation Procedures (SOP) performed during the implementation. The internal task force that manages the dissemination of knowledge in NAHRIM is done

by an appointed and dedicated Steering Committee that is also responsible for monitoring the information, storing and sharing the knowledge. In the initial phase of implementation, the knowledge repository system is functioning based on modules such as illustrated in Table 1.

Table 4. GEDUNG Modules. Source : (NAHRIM, 2008)

Module	Function
Coastal Engineering Information Repository	Online database for accessing documents and meta-data for coastal engineering research
Water Resources Information Repository	Online database for accessing documents and meta-data for coastal water resources research
Lake inventory	Online database for accessing documents and meta-data for lake research
Coastal Resources Risk Index (CORRI)	Online database for accessing documents and meta-data for CORRI
Laboratory and Instrumentation	Online database for accessing documents, meta-data and facilities for Hydraulic and Instrumentation Laboratory
Registry of Experts	Online database of Knowledge Workers of the organisation, or often addressed as Subject Matter Experts (SME)
Waterpedia	Online database for definitions, technical and fundamental terms, abbreviations and dictionary of water related terminology
Waternews	Current issues and archives of news for water and its environment
Water information Repository Portal	Online portal to share all of the above data, meta-data, information and knowledge to the stakeholders and public

In 2012, through the 10th Malaysian Development plan funding, GEDUNG has been revamped and rebranded (namely GEDUNG1NAHRIM) to suit the purpose of integrated knowledge repository system. The system transitioning from a proprietary tool to a collaborative tool (Microsoft SharePoint) that integrates the role of people, process and also technology equally in KM to achieve the business goals. The management of people, process and technology in NAHRIM's KM requires evaluation. Thus, we conducted a knowledge audit to assess the effectiveness of the KM. KA becomes an important tool to monitor the effectiveness of KM implementation by Researchers and Practitioners to investigate the organisations' knowledge availability and needs, its flow and usage in processes, by employees, etc (Gourova & Todorova, 2010).

III METHODOLOGY

The approaches that were used while performing the knowledge audit are visit, literature, survey and interview. The phases for this method involved :

Phase 1: Information gathering from visits to organisation and literature. This phase was to thoroughly gather the information from organisations that implement KM through visits and literature.

Phase 2: KM implementation benchmark. This phase provides a brief description of current KM practices as a benchmark for the KM implementation in NAHRIM that includes how KM was initiated in organisation (KM processes and activities, system and technologies used, knowledge used and needs, etc), and how KM contributes to development of knowledge and social learning, and recommendation for a successful implementation of KM.

Phase 3: Understanding organisation of case study on current KM implementation through survey and interview. Information gathered was to understand the current environment of NAHRIM in managing its data, information and knowledge, through an online survey to all NAHRIM's employees. This process is to identify every knowledge produce by NAHRIM, who produce and use it, how frequent is the knowledge used, and where it is stored. It is aimed to identify the following:

- i. Scarce (uncommon) of information;
- ii. Lack of awareness of information elsewhere in the organisation;
- iii. Inability to keep up-to-date relevant information;
- iv. Any reinvention;
- v. Use of outdated or obsolete information; and
- vi. Unclear path for expertise in a specific area.

Along with the survey, two types of interview sessions took place with the Top Management of NAHRIM, with the expectation to help on defining the current requirements to manage knowledge in the organisation.

Phase 4: Summarising the findings. Findings of KA results for all methods were discussed at the end of the manuscript with some recommendations.

A. Visit and Literature

The data for the initial stage was gathered through a visit that has been carried out at Multimedia Universiti (MMU) and Petroleum Management Unit (PMU), and through a literature review that was done on the other two organisations, Siemens and Malaysian Agricultural Research and Development Institute (MARDI). Comparative Analysis

Framework of KM practices is used to guide our study in this stage that involved :

- i. KM Processes and Activities;

Using the framework, we summarise the KM practices based on our visits and literature on these four organizations that is shown in Table 2.

Table 2. Summary of Initial Requirement Findings on Company Visits and by Literature

KM	iKnow Media, MMU (visit)	PMU, Petronas (visit)	MARDI (literature)	Siemens (literature)
KM Processes and Activities	<ul style="list-style-type: none"> • Knowledge capture through discussion board, shareNet community • Knowledge storage-knowledge banking • Knowledge sharing-K-Space, Pasar Ilmu, k-cafe 	<ul style="list-style-type: none"> • Knowledge capture • Knowledge storage • Knowledge map 	<ul style="list-style-type: none"> • Knowledge capture • Knowledge storage 	<ul style="list-style-type: none"> • Knowledge capture • Knowledge develop • Knowledge reuse
KM Tools and Technologies	<ul style="list-style-type: none"> • ShareNet-Siemen's KM solution, customised for academic purposes • Discussion Forum • Success Story Competition 	<ul style="list-style-type: none"> • Espresso-discussion forum • SKILLS-database of lessons learned • Portals • AXIS-PMU KM portal and knowledge repository • Intranet 	<ul style="list-style-type: none"> • MyFruit • MePIS • AgrobIS • iSMART • AnjungNet 	<ul style="list-style-type: none"> • ShareNet – an intranet that facilitates knowledge transfer
KM Environment	<ul style="list-style-type: none"> • KM Centre –iKnow Media • Research Group –CeKIM (Centre of Excellence of Knowledge and Innovation Management) • Research areas: Soft KM, KMS, Community & Disaster • Capacity Building – Master and PhD in KM 	<ul style="list-style-type: none"> • A dedicated corner for KM Centre • A culture of knowledge sharing 	<ul style="list-style-type: none"> • A culture of knowledge sharing • Community of Practices (CoP) 	<ul style="list-style-type: none"> • Creation of multi-community network
Knowledge Sharing Platform	<ul style="list-style-type: none"> • K-Space(the centre for KM research) • R&D • Pasar Ilmu – Informal Knowledge Sharing Knowledge bank (repository to store knowledge) 	<ul style="list-style-type: none"> • Mainly through the implementation of KMS (internet and intranet) 	<ul style="list-style-type: none"> • Mainly through the implementation of KMS (internet and intranet) 	<ul style="list-style-type: none"> • A network of multiple communities – creation of discussion forums over the network that allow the employees to join more than one community to share their knowledge

- ii. KM Tools and Technologies Used;
- iii. KM Environment; and
- iv. The Delivery Platform (K-Sharing)

MMU was chosen because it is one of local universities that owned an effective KM Centre. PMU successfully implemented KM since 2006 with high commitment from the staffs. Government Research-based like MARDI is similar to NAHRIM and it is actively use KM to capture and disseminate its products' knowledge while Siemens applied KM that has proven to help improving organisational performance (Nielsen & Ciabuschi, 2003)

B. Survey

An online survey was conducted and distributed to all employees to gather information on understanding the current practices of KM in NAHRIM specifically on managing its data, information and knowledge. Survey questionnaire is divided into four sections:

Section 1: Demographic Information. This section is to collect information on the respondents about the gender, age range, position, division/research centre, year of service in the organisation and their awareness on KM. This section can be a primary concern to expect the level of awareness of KM among them based on the demography.

Section 2: Knowledge Profile. Knowledge profiling is aimed to know the respondents' education level and their skill of ICT.

Section 3: Knowledge Requirement/Knowledge Flow Analysis. This section is to gather the flow of knowledge in the organisation that incorporates perception towards knowledge sharing; knowledge inventories (source of knowledge explicit and tacitly); and social interactions between colleagues (communication medium, knowledge and communication problems and barriers).

Section 4. Knowledge Management in The Organisation. This section is to analyse thoroughly how knowledge is managed within the organisation specifically among people, process and technology.

C. Top Management Interview

Two series of interviews were done that comprises the involvement of Top Management Officers of NAHRIM. The main objective is to identify precisely what knowledge the employees possess and what knowledge is lacking that needs to be addressed as the requirement in the future in order to meet the vision of NAHRIM. Six Top Management Officers were selected randomly and two groups of interview sessions were conducted. They were separated into two different sessions due to time constraint and tight workload schedule. Same set of questions checklist were used for both groups with the same procedure. Table 3 below summarise the details of the interviews.

Table 3. Details of Interview Sessions

Interview Session	First Session	Second Session
Date and Time	3 rd June 2014, 12noon	21 st July 2014, 3pm
Venue	NAHRIM	NAHRIM
Interviewees	1. Director of Hydraulic and Instrumentation Laboratory cum Chief Information Officer (CIO) 2. Director of Information Management Division	1. Director of Corporate Planning Division 2. Director of Water Resources and Climate Change Research Centre 3. Director of Coastal Management and Oceanography Research Centre 4. Senior Officer Cum Acting Director of Water Quality and Environment Research Centre

IV FINDINGS AND DISCUSSION

A. Initial Requirement

To summarize, we have uncovered three important elements of KM practices in these four organisations:

- i. These organisations follow the same KM basic processes:
 - a. Knowledge creation,
 - b. Knowledge storage (for preservation) and
 - c. Knowledge application (knowledge is disseminated and shared)
- ii. Three objectives were identified:
 - a. Create knowledge repository,
 - b. Improve knowledge access for re-use and
 - c. Manage knowledge as an asset.
- iii. The implementation of KMS is driven by information technology (e.g portal, intranet).

Lessons learned from these four organisations are:

- i. The success of KM relies on commitment from employees. Employees have to be willing to share knowledge and are committed in contributing their knowledge, be it to the repository or directly face-to-face.
- ii. These companies practice rewards and incentives as a motivation factor to encourage knowledge sharing among their employees.
- iii. Commitment from top management is essential for promoting knowledge sharing among their employees.
- iv. Quality of knowledge content is very important to sustain the use of KMS.

B. Survey

Demographic. Survey respondents represent a balance gender percentage of employees from NAHRIM, 51.4% male and 48.6% female respectively. Majority of them are in age group of 30 to 39 years old (54.2%), followed by 18 to 29 years old (29.2%), 50 above years old (9.7%) and 40 to 49 years old (6.9%). 54.2% of the respondents are employees from the management and professionals, 44.4% from supporting employees and 1.4% from the top management. About 6.9% of the respondents have been working at NAHRIM for more than 10 years, 6-10 years (34.7%), 3-6 years (25%), 1-3 years (12.5%) and less than 1 year (20.8%) respectively. They are from Information

Management Division (19.4%), Coastal Management and Oceanography Research Centre (18.1%) and Water Resources and Climate Change Research Centre (15.3%) and followed by other department/ research centres.

Knowledge Profile. One of the objectives of the study was to identify the level of awareness about KM among organisation's employees. 50% of the respondents ever heard and understood KM well while the other 36% of them have heard about the term but did not understand the meaning of it. 14% of them had never heard of KM and no awareness on KM at all. More than 50% of the respondents that do not understand KM were from the age group of 18-29 and 30-39 years old. Hence, the organisation needs to further educate their young employees about KM as well as making them actively involve in future KM implementation.

Knowledge Requirement/Knowledge Flow Analysis. One of an important aspect assessed was on the knowledge sharing among members of departments and inter-departments. Most of them agreed that their department facilitates knowledge creation, storage, access or retrieval and knowledge transfer. Respondents agreed that NAHRIM should encourage and promote knowledge sharing in current work environment and they somewhat agree that the office environment helps them to do their work effectively and efficiently. In a way, the employees realised that knowledge sharing is beneficial for them to improve their job performances, thus increasing their willingness to implement knowledge management in their work and change their work culture.

Knowledge Management in The Organisation. The result indicates that 68% employees do not think that the information stored in GEDUNG1NAHRIM is useful and important for their work as they still rely on resources stored in their private folders and files found in the intranet such as Network Acces Storage to do their work that may be due to easy access within network and file folder based, rather than web-based. Most of the respondents (83%) agree that the most useful knowledge resources can be found in the electronic files on their PC.

Meanwhile, the employees are still facing problems to find information related to their work. Sometimes the respondents are not sure what they should do when they face problems at work, how to solve the problems, to whom should they collaborate and where to find relevant information to solve problems at work. Respondents answered on a 5-point scale with 5 representing the highest score (Rarely-Always). The result suprisingly shows that knowledge in NAHRIM is not managed properly,

and the current information management system does not meet their KM implementation objective.

C. Top Management Interview

The top management of the organisation believes that the organisation will benefits a lot from KM, but some of them found that it is a hard to express the expectation of the actual benefits of KM specific to their jobscope. The expectation includes; improved decision making time, enhance quality of service and improve delivery time. However, when asked whether they are facing problems to search for information for decision making needs, they agreed that sometimes they could not find the information needed. One of them mentioned that sometimes they have problems to access knowledge from external expertise, as some specific knowledge is not available internally. Currently, information about research such as technical reports, technical guide, journals and non-confidential report are stored in GEDUNG1NAHRIM and raw data related to research projects are mainly kept in internal shared drives (Network Access Storage). Sources of knowledge mainly coming from the experts themselves, internal repositories, and network access storage, while external sources come from other organizations' repositories (i.e universities, Intergovernmental Panel on Climate Change (IPCC) reports, Natural Resources and Environment (NRE) reports, government) and also from the Internet.

According to the interviewed senior managers, knowledge management aims of storing tacit knowledge of the experts is a good initiative, but some of them were not convinced when it comes to practical implementation of this idea. Currently, they try to avoid working in silo to ensure that their expertise is shared with others and to avoid depending on one expert for knowledge related to specific problem area. They encourage teamwork within department or research centre and also knowledge sharing across departments as some of the projects involve multidiscipline research area. Most of the time, they use email for sharing knowledge with their colleagues, besides formal or planned meetings and discussion sessions.

While most of the Top Management personnels are positive about the knowledge management initiative, a few were sceptical about the KM implementation. Some uncertainty exists in the minds of the managers regarding the scope, objectives, and role of KM initiative in the organisation. Overall, the commitment to knowledge management is generally positive. They have not defined which knowledge areas are critical in order to improve its current or future performance as they believe all knowledge of

different research centres and business division are equally important.

V RECOMMENDATION

The finding of this study indicates that NAHRIM holds large volumes of data, information and knowledge that reside in GEDUNG1NAHRIM and also in the Subject Matter Experts (SME). As these examples demonstrate, NAHRIM stores, manipulates, and produces a great deal of data and information. Certain elements of KM do exist in NAHRIM in terms of technology. It includes;

- i. Official website – a portal that enables retrieval of information;
- ii. GEDUNG1NAHRIM - for storing and retrieval documents;
- iii. Network access storage – provide commonly accessed documents through internal shared drives or intranet.

While these technologies are considered as key resources of information, they do not focus on a core component of KM that is, people. KM is not only concern about managing information, but also emphasise on managing experts. The current systems do not store knowledge of employees, thus making the current management of people (SME), were left behind. They are at the risk of losing its extensive tacit knowledge as a result of retirement of its senior employees, staff resigning or transferred. We recommend that SME management needs to be taken into account for the organisations' future KM enhancement. Experts profiling, for example can be implemented and become a reliable tool for other employees and stakeholder of the organisation, such as Academia and Researchgate. Finding experts, binds with their research area of expertise, publications, technical papers, achievements and level of competency such as using semantic enrichment web searching is one of a growing approach nowadays (Thiagarajan, Manjunath, & Stumptner, 2008). With this, we suggest technology like web semantic for example, to be incorporated with existing KM because it enables the network relationship, information and knowledge among experts in NAHRIM and outsiders within the same domain of expertise so that it can lower the risk of losing experts' knowledge.

VI CONCLUSION

We concluded that the current systems used in NAHRIM have certain elements of KM in terms of

technology used such as the repository systems, databases, official websites and network access storage that enable knowledge to be stored, and shared across organisation. However, lack of experts' management may cause problems of NAHRIM to lose their strategic values of knowledge that may affect the organisation's survival, continuity and sustainability. They should apply KM best practices that combine people, process and technology as the key elements of KM, and managing organisational change through change management programme.

ACKNOWLEDGEMENT

Authors would like to thank the Economic Planning Unit of Prime Minister's Department for the 9th and 10th Malaysian Plan funding of this project.

REFERENCES

- Academia. Retrieved April 1, 2016, from <https://www.academia.edu/>
- Choy, S. Y., Lee, W. B., & Cheung, C. F. (2004). A Systematic Approach for Knowledge Audit Analysis: Integration of Knowledge Inventory, Mapping and Knowledge Flow Analysis. *Journal of Universal Computer Science*, 10(6), 674–682. <http://doi.org/10.3217/jucs-010-06>
- Gourova, E., & Todorova, Y. (2010). Knowledge audit data gathering and analysis. *Proceedings of the 15th European Conference on Pattern Languages of Programs - EuroPLoP '10*, 1. <http://doi.org/10.1145/2328909.2328927>
- Malaysia Administrative Modernisation and Management Planning Unit (MAMPU). (2011). *Knowledge management blueprint. Public Sector ICT Blueprint*. Cyberjaya, Malaysia. Retrieved from <http://www.mampu.gov.my/documents/10228/11852/KNOWLEDG E+MANAGEMENT+BLUEPRINT.pdf/e8e4c887-3921-44b6-ab8d-ac16614bec74>
- Mohammad Fikry, A., Juhaimi, J., & Salmah, Z. (2008). *The Development of Gedung - An Information and Data Sharing Repository Platform For Hydraulic Research in Malaysia. The Development of Gedung - An Information and Data Sharing Repository Platform For Hydraulic Research in Malaysia*. Seri Kembangan, Selangor.
- NAHRIM. (2014). *Knowledge Information Integration (KI2)*. Seri Kembangan, Selangor.
- Nielsen, B. B., & Ciabuschi, F. (2003). Siemens ShareNet: Knowledge Management in Practice. *Business Strategy Review*, 14(2), 33–40. <http://doi.org/10.1111/1467-8616.00257>
- Researchgate. Retrieved April 1, 2016, from <https://www.researchgate.net/home>
- Thiagarajan, R., Manjunath, G., & Stumptner, M. (2008). Finding experts by semantic matching of user profiles. *CEUR Workshop Proceedings*, 403, 7–18.

Strategy Mining on University Students' Feedback

Angela Lee Siew Hoong and Tong-Ming Lim

Sunway University, Malaysia, {angelal; tongmingl@sunway.edu.my}

ABSTRACT

Strategies can be mined by analyzing advices and recommendations from university students. Useful knowledge from text analysis surface potential new strategy, which can be used by university operators. Strategy in this context is defined as a plan of action or policy that gives direction. In the contact of students' feedback, outcomes of text mining can be presented as concept map where key concepts and sub concepts are linked and hence provide directions. However, these linked concepts are not final strategy but rather preliminary draft 'strategy' or 'direction' where fine-tuning is required. The analysis also presents clusters of concepts where themes that are closely interrelated are put into the same cluster so that different strategy can be formed on different issues. The feedback in this research consists of advice and recommendations of the university students in a yearly university survey. The text mining methodology used in this research entails text parsing, filtering, and topics and clustering of themes once these unstructured texts are pre-processed. This paper concludes by drawing several issues to the attention of the institute.

Keywords: Strategy, text mining, feedback, concept map.

I INTRODUCTION

Strategy is a set of actionable items that consist of policy and rules that provide direction for an organization. Strategy can be mined from advices and recommendations from students in a university. University students express themselves in many forms. Some pour out their unhappiness and dissatisfaction on social media platforms such as Facebook and Twitter. Some choose to file their complaints to the administrators of the universities. In order to obtain voices from these students, universities in Malaysia carry out survey periodically to collect their feedback and analyze them in order to listen to students' voices. Their voices in the form of unstructured text are analyzed and used so that draft strategies in the form of rules can be obtained. Analyzing unstructured text can be carried out using text analytics. In the text analysis, concepts and sub concepts, discussion topics and cluster of themes are highlighted by the process of text analysis. Some past research has provided evidence with respect to the research topic in this paper (Leeman-Munk, Wiebe &

Lester 2014; Blikstein, 2011; Grant, 1991; Weber and Mateas, 2009). RELATED WORKS

Weber & Mateas (2009) presented a data mining approach to opponent modeling in strategy games. Expert gameplay is learned by applying machine learning techniques to large collections of game logs. This approach enables domain independent algorithms to acquire domain knowledge and perform opponent modeling. Machine learning algorithms are applied to the task of detecting an opponent's strategy before it is executed and predicting when an opponent will perform strategic actions. Their approach involves encoding game logs as a feature vector representation, where each feature describes a unit or building type is first produced. In their research, also compare representation to a state representation in perfect and imperfect information environments and the results show that representation has higher predictive capabilities and is more tolerant of noise. They also discuss how to incorporate data mining approach into a full game playing agent.

In Grant (1991) paper, he stated that strategy is defined as "the match an organization makes between its internal resources and skills and the opportunities and risks created by its external environment". In Leeman-Munk, Wiebe & Lester (2014) work, they pointed out that real-time formative assessment of student learning has become the subject of increasing attention. Students' textual responses to short answer questions offer a rich source of data for formative assessment. However, automatically analyzing textual constructed responses poses significant computational challenges, and the difficulty of generating accurate assessments is exacerbated by the disfluencies that occur prominently in elementary students' writing. With robust text analytics, there is the potential to accurately analyze students' text responses and predict students' future success. They presented WRITEEVAL, a hybrid text analytics method for analyzing student-composed text written in response to constructed response questions. Based on a model integrating a text similarity technique with a semantic analysis technique, WRITEEVAL performs well on responses written by fourth graders in response to short-text science questions. Further, it was found that WRITEEVAL's assessments correlate with summative analyses of student performance.

Ferguson & Shum (2011) pointed out that generic web analytics tend to focus on easily harvested quantitative data, Learning Analytics will often seek qualitative understanding of the context and meaning of this information. This is critical in the case of dialogue, which may be employed to share knowledge and jointly construct understandings, but which also involves many superficial exchanges. Previous studies have validated a particular pattern of “exploratory dialogue” in learning environments to signify sharing, challenge, evaluation and careful consideration by participants. This study investigates the use of sociocultural discourse analysis to analyze synchronous text chat during an online conference. Key words and phrases indicative of exploratory dialogue were identified in these exchanges, and peaks of exploratory dialogue were associated with periods set aside for discussion and keynote speakers. Fewer individuals posted at these times, but meaningful discussion outweighed trivial exchanges. If further analysis confirms the validity of these markers as learning analytics, they could be used by recommendation engines to support learners and teachers in locating dialogue exchanges where deeper learning appears to be taking place.

II PROBLEM STATEMENT AND OBJECTIVE

Formulating strategy for any organization has never been an easy thing to do. The Malaysia Ministry of Education has conducted a yearly university experience survey to both Malaysian and international students in order to understand their needs and areas of improvement. These surveys have generated a lot of data such as advices and recommendations in the form of unstructured text. However, due to skill, expertise and resources constraints by these universities and the ministry, these comments and feedback were not analyzed and looked at seriously using text analysis. More than often, the analysis is only carried out manually. Considering the amount of unstructured text that one needs to read and analyze, it is not efficient and productive. This research focuses on advice and recommendations provided by the students. The objective of this research is to analyze the feedback from all the students in the university to highlight key concerns and sub concepts. From the analysis of these key terms, important issues can be examined and strategies can be formed to resolve and improve the issues concerned. Text cluster and topics are used to exhibit themes from these unstructured texts. The advice and recommendations from students that are grouped can be used to form draft university strategy. This paper attempts to answer “Can advise

and recommendations from students are good to be used as draft strategy mined from their unstructured text?”.

III RESEARCH METHODOLOGY

An annual survey was carried out by a private university to obtain feedback on students' university lifestyle. Data collected was secondary and the feedbacks are in unstructured text format. The main participants for this research was students and all are asked to enter their feedback on a voluntarily basis. The total population of the university is the total population size for this research. Students name and private details are not expose in this research due to data privacy and confidentiality. Analysis of this research was carried out using SAS Eminer. Text mining node was used to analyze any corpus of documents or texts. Text parser breaks sentence into tokens or terms. The reasons of doing so are to eliminate unwanted noises from these sentences in order not to be processed further. Parsing activity output will be inputs into text filter. The text filter node were chosen to process keyterms based on dictionary used, multi-terms, stem words, stop-list and start-list definitions. In SAS EMiner, Text Cluster node will discover themes for each terms. Meanwhile the Text Topic node will discover themes but assign each document to zero or more of those themes. Text Cluster node is suited for documents that generally focus on a particular topic because when multiple concepts are present in a document, the chosen theme could be 'biased' (for lack of a better word). This allows analysis in the paper to examine key issues in the form of key terms from the students' feedback. Visual concept maps are used to link key concept (from the key term) to related sub concepts. Lastly, topics and clusters are highlighted by the text miner software.

IV ANALYSIS AND DISCUSSION

In this section, key terms that are concept mined from the unstructured text are ranked using weight (or level of importance). All the concepts (or terms) will be grouped as topics and clusters of themes to be highlighted to the university operators for the formulation of strategy and hence improve quality of university students' experience. In this analysis, topics or themes and cluster of themes surfaced by the software will be discussed. In addition, each topic is examined closely in this section. Multiple themes surface from corpus of feedback (because each feedback is stored in an individual database cell) are grouped in each cluster. The outcomes of the text analysis are analyzed and explained in the following sections.

a. Advice Given to Junior Students

The feedback captured on advice given to junior students provide information on study, cost of living, attitude, living environment, saving tips and so on. From the feedback obtained, several issues arise. The following are several key terms that are important: “environment”, “procrastinate”, “journey”, “institution”, “program” and “result” (Figure. 1). Figure 2 illustrates key concepts and their relevant sub concepts visually. The thickness of the line that link between two terms (or concepts) indicate they are closely related. Once notices that “student” and “friendly” are linked by a bold and thick line. This allow one to drill down the actual feedback provided by the students to examine the actual issue on these two concepts. Other link that has thick bold line includes “student” – “different” – “country”.

TERM	FREQ	# DOCS	KEEP	WEIGHT ▼
environment	6	4	✓	0.76
procrastinate	5	4	✓	0.76
journey	5	4	✓	0.76
institution	5	4	✓	0.76
program	5	4	✓	0.76
result	5	4	✓	0.76

Figure. 1. Key terms based on Advice Feedback

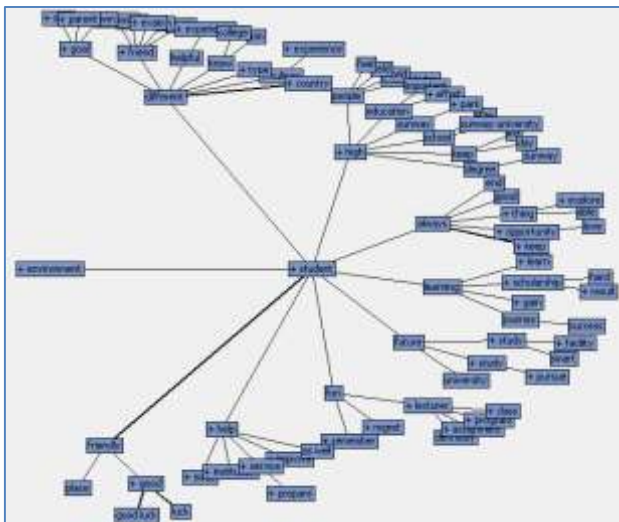

Figure. 2. Concept map for “Environment”

In Figure. 3, samples feedback on “Environment” are listed. This allows detail examination on the advice provided by the students hence formulating strategy becomes more accurate. The “journey” concept map is illustrated in Figure. 4.

The overall experience in Sunway has been great as most of the lecturers are helpful and easy to approach. However, there should be more improvement on the environment of the entire campus

In order to succeed, your desire for success should be greater than your fear of failure, you must refuse to be a captive of the environment in which you find yourself.

Prepared your own packed food because the food is quite expensive due to the living cost. If he or she can afford it, then is fine. Computer service is first come first serve so be quick otherwise it will be taken by other students. Hope you can tolerant hot condition because the environment is pretty packed and crowded resulting a stuffy and uncomfortable environment.

If you want to aces in your studies, go home and study as the school environments is not catering for student to do revision but more to socialize like a food court environment, that if you are going to study in Sunway University. Be involve in Student community :)

Figure. 3. Samples feedback for “Environment” key term

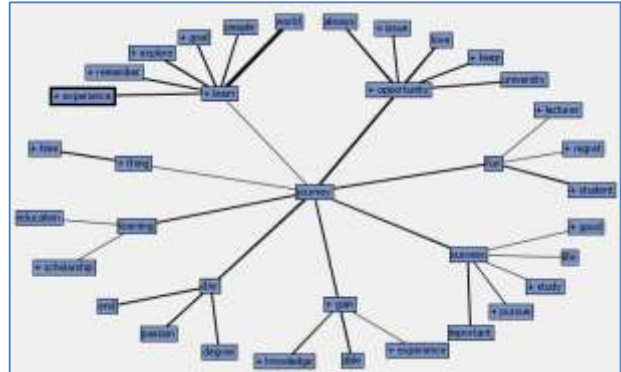

Figure. 4. Concept map for “journey”

In Figure. 5, a sample of feedback were extracted. Based on the links that are highlighted in thick bold lines, a close examination can be carried out based on the concept links. For example, concept links for "journey" - "opportunity" - "university", "learn" - "world" and "learn" - "experience" can be further zoomed into the actual advice provided by their senior.

Knowledge is one of the best gift anyone can give to themselves because with knowledge one is empowered to go out in the world and make something out of themselves and to give back to society. If you have the opportunity to study at a University and take up a course make good use of everything that is offered, that is your right, don't take things for granted (ie. always be humble, respect others point of view, show gratitude),persevere and keep going even when it gets tough because the fruits that you will yield at the end of the day will be worth every last sweat you poured into becoming the person you are. Work hard but remember to have fun. Apply the things you have learnt, don't just learn something because it is in the course syllabus or because you have to do it in order to finish the semester do it with a passion, gain something from what you are doing and use the knowledge you have gained in your everyday life because that is when you learn best. You learn best when you are able to apply what you have learnt to the world we live in. Don't ever stop learning, there is so much to explore, so much to gain, so much to do; always have a thirst for knowledge and you will never go hungry another day in your life. Make something your trade and give back to the world to the best of your ability, leave an everlasting mark on the world and a strong imprint in the people you come in contact with because that is what will be remembered by people you live behind when you time is up. Be the best you can ever be and share your ability and talents with the people around you as that is what will make you a rich person spiritually and you will always feel whole. Knowledge is power, now and forever. All the very best to all you students out there who will be embarking on this fulfilling journey, trust you will never regret

Education should be a journey of fun learning! Everyone is capable of gaining a scholarship, as long as effort is put into what you do.

Do your best and strive for success due to the hardship faced. Hopefully you manage to secure a good career prospects and it will brighten up your journey in future!

Figure. 5. Samples feedback for “Journey” key term.

“Institution” is another key term that was highlighted by students. The concept map in Figure. 6 shows a snapshot of the linked concepts.

life, enjoy, live, +full, live
 +study, hard, smart, +scholarship, +full
 good luck, luck, +good, play, job
 sunway, +lecturer, +experience, better, +remember
 different, +country, +culture, +friend, +type
 sunway university, +lecturer, +good, join, +program
 give up, +pay, work, smart, dont
 +choose, wisely, +regret, +friend, enjoy
 sunway, join, +park, +friend, +experience
 success, +opportunity, important, help, hesitate
 +learn, +thing, world, +knowledge, people
 always, good, +good, give up, +procrastinate
 +student, +help, +experience, future, +scholarship
 +work, hard, play, fun, enjoy
 +want, stay, +pursue, +stay, passion
 school, stay, fun, +high, place
 future, join, know, better, +prepare
 hard, work, +help, +good, college
 +hard, +friend, fun, +work, smart
 money, waste, +time, waste, especially
 +study, better, dont, +pursue, sunway university
 +find, +good, food, enjoy, +environment
 +scholarship, education, college, +result, +good
 +time, +friend, know, +exam, college
 university, +facility, enjoy, people, +service

Figure 12. Topics discussed by students on “Advice”.

b. Recommendation from Students

This sections examine recommendation remark from the students. The text analysis highlights four (4) key terms that are of high concern by the students include “different”, “person”, “park”, and “world” (Figure. 13).

TERM	FREQ	# DOCS	KEEP	WEIGHT ▼
different	6	4	<input checked="" type="checkbox"/>	0.706
person	5	4	<input checked="" type="checkbox"/>	0.705
park	5	4	<input checked="" type="checkbox"/>	0.705
world	5	4	<input checked="" type="checkbox"/>	0.705

Figure 13. Key terms for “Recommendation” feedback.

Figure. 14 illustrates the concept map for “different”. Links that connect several important key concepts are "good" - "sunway university", "good" - "lecturer", "different" - "student" - "sunway university", "different" - "people" - "world".

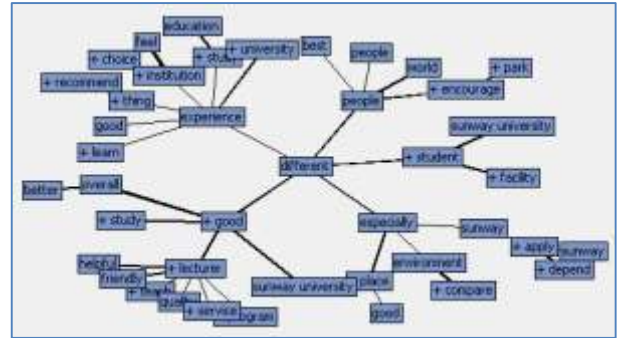

Figure 14. Concept map for “Different”.

Figure 15 displays sample feedbacks for “different”.

Ambience here in Bandar Sunway is good(high-class) but sometimes hazy. People here nice and it's an English-speaking environment, important for students to go pursue their life elsewhere in the world. Course fee is considerably affordable with the help of PPTN. I can also see the effort of Jeffrey Cheah, Elizabeth Lee & relevant authorities in dedicating their best to educate the youngsters (Good or bad the effort shall be appreciated because it doesn't sound easy to manage a bunch of people). Sunway University will be the choice after local university (different life-style, I personally prefer less-materistics environment unlike here and cost of living in a city is high too, students loss quite a sum of money in the long run). I appreciate the well-maintained swimming pool in Sun-U residence, a good place to swim and relax). I would also suggest the management team of Sunway to build a runway for the students and staffs who walk or cycle to school for the sake of Mother Earth and the health of the people especially the students. Car usage shall be reduced just like in the other foreign countries and at least to me it is a better policy. It takes time, effort, money, resources etc to change but why shall we not give it a try? The world is changing. Sunway shall be the one who leads. That's all from me. Thanks.

Good studying place and learning experience, but services, especially synchronization between different management departments can be much better. Currently, the student is supposed to synchronize the info from different departments.

Figure 15. Samples feedback for “Different” key term.

Figure. 16 illustrates concept map for “Park” concept.

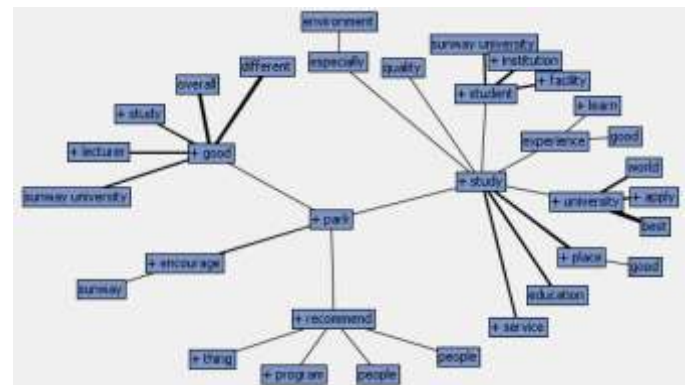

Figure 16. Concept map for “Park”.

Samples of feedback on “Park” are presented in Figure. 17.

If I encourage them, where will they park? The university has good programs but terrible parking services. I wouldn't recommend people to study here if all they are going to be doing is paying for summons on top of the tuition fees.

Awesome lecturers and very convenient as shopping mall and leisure park is just a walking distance away

Figure 17. Samples feedback for “Park” key term.

Figure. 18 illustrates the concept map for “World”.

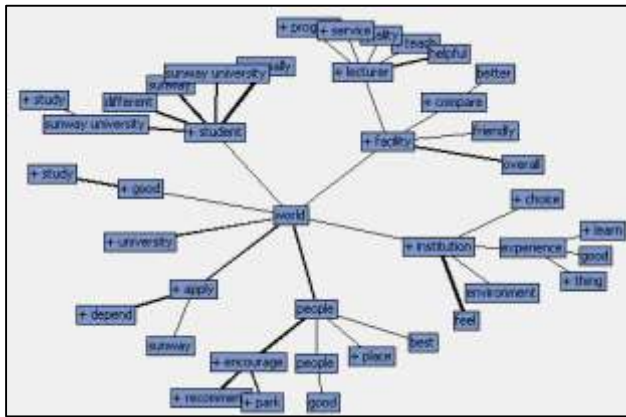

Figure. 18. Concept map for “World”.

Some links that connect important concepts are "world" - "student" - "sunway university", "world" - "institution" - "feel", "world" - "people" - "encourage" where samples feedback are illustrated in Figure 19.

The institution is already overcrowded, and some of the facilities are just unusable. The road connecting the institution to the outside world is like the surface of the moon.
I have been impressed with Sunway University even before I applied to study here. For one, the generosity of the University and the JCF in providing scholarships to deserving students have always attracted my attention. Not only does this provide many students with opportunities for good education, it helps lighten the burden of many students who find it difficult to afford tuition fees. The collaboration between Sun-U and many esteemed institutions around the world including Lancaster University, Victoria University and Le Cordon Bleu also impressed me and many of my peers.

Figure. 19. Samples feedback for “World” key term.

In Fig. 19, the concept map for “Improvement” is illustrated. The “Improvement” concept is found to have stronger link to “park” – “car” – “space” where Fig. 20 illustrates sample feedback on the “Improvement” concept.

Figure. 20 and 21 show the themes generated by the text miner presented by the text cluster. In the text cluster, “+teach +thing +recommend sunway different good people +encourage +good education experience +lecturer” has a much higher weight which means this cluster and all the feedback in this cluster is a more important set of concepts.

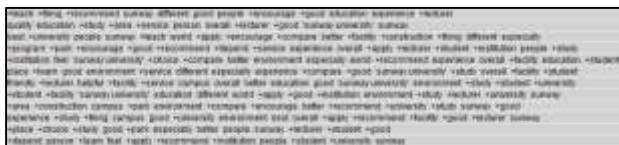

Figure. 20. Cluster of themes.

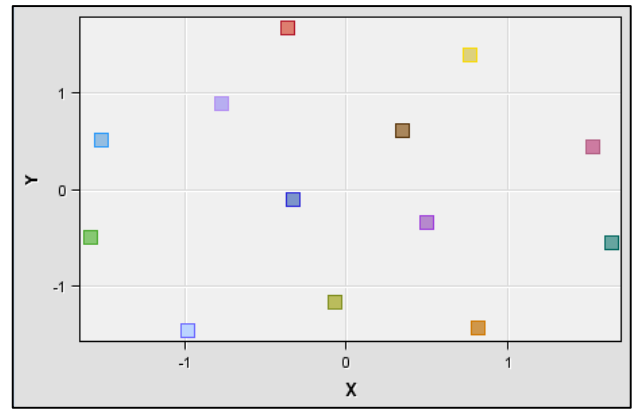

Figure. 21. Cluster of themes.

Figure 21 demonstrates that all the clusters are clearly independent of each other. Figure. 22 illustrates a list of topics produced by the text topics function of the text miner software. Topic one consists of “+place +study +park +lecturer people”, for example, has the highest weight which is the most talk about topic among students. For strategy formulation, it is easier and effective with the right topic being surfaced and highlighted to the university operator.

```
+place,+study,+park,+lecturer,people
+student,different,especially,+learn,sunway
+apply,+depend,sunway,+student,+study
person,+learn,+depend,quality,people
+lecturer,+teach,sunway,+good,+university
sunway,best,+university,overall,people
+institution,world,+apply,+university,feel
+encourage,+park,people,+recommend,+good
good,sunway,people,+thing,+recommend
+study,education,quality,+area,+place
+facility,+university,+good,overall,better
campus,better,+thing,+study,helpful
+choice,better,+institution,+learn,+depend
overall,quality,+good,education,+study
sunway university,+recommend,+service,quality,better
friendly,helpful,+lecturer,+learn,overall
people,education,different,world,best
environment,+compare,+institution,+area,+service
+program,+recommend,+depend,+park,overall
place,+compare,+service,different,helpful
+area,+construction,+learn,+park,education
sunway university,+recommend,education,friendly,+good
experience,+learn,+university,+study,overall
feel,+compare,better,+thing,education
good,+learn,+thing,+lecturer,especially
```

Figure. 22. Topics discussed by students on “Recommendation”.

V DISCUSSION AND CONCLUSION

The number of advice and recommendations remarks from students are large and to do a comprehensive analysis manually will not be very effective and accurate. The use of text miner to analyze unstructured text to highlight new knowledge, new direction and strategies is a new approach in the process of strategy finding. In this paper, several

potential strategies based on the key concepts can be derived:

- “park” – “car” – “space” can be interpreted as “car park space is not sufficient”
- "world" - "student" - "sunway university" is “students in sunway university is from worldwide”
- "world" - "institution" - "feel" is interpreted as “it feels like world institution”
- "good" - "lecturer" is interpreted as “good lecturer in sunway university”
- "different" - "people" - "world" is interpreted as “different type of people from the world”

“result” – “hard” – “work” is interpreted as “to get result must work hard” Strategy can be deriving by simply looking at the relationship between two key terms from the text mining output. When the term park; car and space are link closely it means students complaints about not having enough car park space, hence the management of the universities should take note of how to manage and provide more space to solve this problem.

REFERENCES

- Leeman-Munk, S. P., Wiebe, E. N., & Lester, J. C. (2014, March). Assessing elementary students' science competency with text analytics. In Proceedings of the Fourth International Conference on Learning Analytics And Knowledge (pp. 143-147). ACM.
- Ferguson, R., & Shum, S. B. (2011, February). Learning analytics to identify exploratory dialogue within synchronous text chat. In Proceedings of the 1st International Conference on Learning Analytics and Knowledge (pp. 99-103). ACM.
- Blikstein, P. (2011, February). Using learning analytics to assess students' behavior in open-ended programming tasks. In Proceedings of the 1st international conference on learning analytics and knowledge (pp. 110-116). ACM.
- Shrimoyee M. (2014) Theoretical Framework for analyzing International Students' Concept of Expectation and Consumer Satisfaction in an International University, E-Leader Bangkok 2014.
- Kok, J. K., Cheah, P. K., & Ang, S. M. (2011). The Role of the University: Malaysian Students' Perceptions. *Science*, 37, 20-00.
- Bashir, S., Sarki, I. H., & Samidi, J. (2012). Students' perception on the service quality of Malaysian universities' hostel accommodation. *International Journal of Business and Social Science*, 3(15).
- Rasli, A., Shekarchizadeh, A., & Iqbal, M. J. (2012). Perception of service quality in higher education: Perspective of Iranian students in Malaysian universities. *International Journal of Academic Research in Management (IJARM)*, 1(1).
- Che Rozaniza Azizan, Asbah Razali, Rajalingam Pillai. Promoting Positive Mental Health among Students in Malaysia. *Psychology and Behavioral Sciences*. Vol. 2, No. 2, 2013, pp. 73-82. doi: 10.11648/j.pbs.20130202.18.
- Weber, B. G., & Mateas, M. (2009, September). A data mining approach to strategy prediction. In *Computational Intelligence and Games, 2009. CIG 2009. IEEE Symposium on* (pp. 140-147). IEEE.
- Grant, R. M. (1991). The resource-based theory of competitive advantage: implications for strategy formulation. *California management review*, 33(3), 114-135.

Knowledge Management, Innovative intelligence and Sustainable Competitive Advantage in Small and Medium Enterprises

Rohana Ngah, Zarina Salleh, and Ismail Ab Wahab

Universiti Teknologi MARA, Malaysia, {hana.ngah; zarsalleh; iwahab596} @gmail.com

ABSTRACT

This study is to explore the relationship of knowledge management, innovative intelligence and sustainable competitive advantage by using partial least square. Knowledge management practices are known for its impact on organizational performance however, it is yet to be explored on sustainable competitive advantage especially on Small and Medium Enterprises (SME). This study is also attempts to explore the role of innovative intelligence in mediating the relationship. Hundred twenty questionnaires have been collected from knowledge-based SMEs. Partial least square analysis is used in the analyses to determine the relationships. Knowledge management was found to have indirect relationship with sustainable competitive advantage where innovative intelligence served as a mediator of the relationship of knowledge management and sustainable competitive advantage. The findings showed that SMEs have not exploited their organizational knowledge to develop sustainable competitive advantage through innovation. Innovative intelligence is identified as an important catalyst for SMEs to sustain its competitive advantage.

Keywords: Knowledge Management Practices, Innovative intelligence, Sustainable Competitive Advantage.

I INTRODUCTION

Knowledge management is a weapon for company's competitive advantage (Lee & Choi, 2000). According to OECD report (1996), knowledge-based economy is an economy that is directly based on the production, distribution and use of knowledge and information. Knowledge plays a greater role in productivity and economic performance. Knowledge management (KM) has become an important component for sustaining competitive advantages. Small and medium-sized enterprises (SMEs) play an important role in the Malaysian economy. SMEs contributed to 99% of business establishments in Malaysia. It contributed 33% to Malaysia GDP. SMEs are known to be poor in practicing a complete knowledge management due to cost and expertise (Montequin et al., 2006). However, SMEs commonly practice knowledge sharing through informal interactions. However, knowledge management practices can help

SMEs to be more competitive and innovative as well as can lead SMEs to sustainable competitive advantage (SCA). In addition, KM can also help to improve organizational and individual performance (Friedman & Prusak, 2008). Knowledge management is commonly practiced in large organizations and has been proven to contribute to the organization's success. SMEs can benefit from KM practices regardless of their size and location (Okuneye & Karsten, 2002). Not many studies of KM practices have been done on SMEs especially on SCA thus this study would explore the relationship of KM, innovative intelligence and sustainable competitive advantage in exploring any possibilities.

II LITERATURE REVIEW

A. Knowledge Management and Sustainable Competitive Advantage

In a knowledge economy, knowledge remains as the main resources for companies to gain its competitive advantage. If knowledge in the organization is properly managed and become formalized, the organization can achieve its strategic competitive advantage compared to its competitors (Chikati & Mpofu, 2013). Knowledge management is a process that supports organization to acquire, accumulate, create, disseminate and protect important knowledge so as to exploit their knowledge-based resources thus propel them to be innovative in the market (Khan, 2014) as well as furthering the organization's objectives (Davenport & Prusak, 2000). Competitive advantage is the aspects enterprises have to go beyond or better than competitors in the specific business (Wei et al. 2010) while Wu (2010) described the competitive advantage as the value creation, value capture and value protect (Mahdi et al., 2011). According to Barney (2008), competitive advantage is temporary where it will result in profit and attract competition which shortens the company's competitive advantage while sustainable competitive advantage is when competitors are unable to imitate the source of advantage or if no one produces a better offering for a long period of time (Barney, 2008). Companies that effective and efficiently manage their organizational knowledge will be able to create and sustain its competitive advantage (Deel & Hill, 1996). Knowledge management can play a role in sustaining competitive by transforming knowledge from tacit to explicit and from individual to organizational (Gao et al. 2008).

B. Knowledge Management and Innovative intelligence

Knowledge is the main important ingredient for innovation. In today's knowledge economy, organizations must rely on innovation as a source of competitive advantage (Weiss & Legrand, 2011). Many studies found that knowledge management leads to innovation (Mathews, 2003). Intelligence can be defined as the ability to apprehend the interrelationship of presented facts in such a way to guide towards the desired goal (Ahmad, 2015). Merriam-Webster dictionary provides a definition of intelligence as the ability to apply knowledge to manipulate one's environment. Intelligence has been a main focus of organizations to survive the competition. Few type of intelligence has been discussed for sometimes such as competitive intelligence (Danet, 2006), financial intelligence (Sternberg, 2004), emotional intelligence (Amy, 2010; Erin B. McLaughlin, 2012) and multiple intelligence (Weiss & Legrand, 2011). Weiss & Legrand (2011) promote that companies must have intelligence pertaining to innovation in order to identify and exploit innovation in the company to gain competitive advantage. They defined innovative intelligence is defined as the human cognitive ability to gain insight into problems or opportunities in new ways and to discover new and unforeseen implementable solutions (Weiss & Legrand, 2011). It is important for the company to acquire innovative intelligence as it creates the capability to gain insights into complex problems or opportunities and discover new and unforeseen solutions that can be implemented (Ünay & Zehir, 2012). The ability of SMEs to use innovative intelligence is crucial to achieving competitive advantage in the competition. Innovative intelligence can help SMEs to discover business opportunities through knowledge management.

C. Knowledge Management and Innovative intelligence and Sustainable Competitive Advantage

Innovation has become the backbone of every company (Tidd and Bessant, 2011). However, innovation has become increasingly difficult and challenging due to changing customer needs, competitive pressure and rapid technological change (Cavusgil et al., 2003). KM supports innovation through new ideas and exploitation of organization's knowledge and thinking power (Parlby & Taylor, 2000) which helps company develops and sustains its competitive advantage. Knowledge resides in people and structure. As knowledge management helps to change from tacit knowledge to explicit knowledge, this can create and develop innovative intelligence in the company. For SMEs, smaller size helps them to discover their innovative intelligence thus produce

innovation output to sustain their competitive advantage. Knowledge management has been said to have an impact the sustainable competitive advantage in large companies but remains vague in SMEs. SMEs might be able to create competitive advantage but having difficulty in sustaining it. According to Rangone (1999), basic capabilities for SME's sustainable competitive advantages are innovation capability, production capability, and market capability.

III RESEARCH METHODOLOGY

The study population comprises owners, senior managers, and managers of SMEs that operating in central of Malaysia. A purposive sampling technique was employed because the relevance of its nature to this study. To ensure meaningful data are collected, each respondent was required to acknowledge that his company is involved in R&D and innovation before completing the questionnaire. About 140 responses were received from 300 questionnaires distributed indicated 45 percent of response rate. However, 5 were rejected due to errors in completing sections of the questionnaire. Data were collected using a questionnaire which used a seven-point Likert scale response format. Survey items were developed from a review of the literature and pilot tested with 10 SMEs' owners. Not many changes were made to the final version of the questionnaires. Knowledge management practices measurement was adapted from Lee & Choi (2002), Gold et al (2001) and Nonaka & Takeuchi (1995) and sustainable competitive advantage measurement was adapted from Zabid (2000), Bamberger (1989), Roberts & Grover (2012) and Wu et al. (2007).

IV FINDINGS

The demographic profile of respondents is presented in Table I. There was almost equal representation from manufacturing and service sectors of 41.9% and 58.1 respectively. Majority has between 5-75 workers and majority of SME recorded annual sales turn-over in between RM300, 000 to 15 million. About 28% of SMEs have been operating more than 10 years and the majority has been in business for 5-7 years.

To assess the model, SmartPLS M3 2.0 (Ringle et al., 2005) was used to estimate the parameters in the outer and inner model. PLS tries to maximize the variance explained of the dependent variables. It offers many benefits with respect to distribution requirements, type of variables, sample size and the complexity of the model to be tested. This study utilized PLS path modeling with a path-weighting scheme for the inside approximation (Chin, 1998; Tenenhaus et al., 2005; Wetzels et al., 2009). Nonparametric bootstrapping approximation was applied with 200 resampling to obtain the standard

errors of the estimates (Chin, 1998; Tenenhaus et al., 2005; Wetzels et al., 2009).

Table 1. Demographic Profile of Respondents

Variables	Category	Frequency	%
Sector	Manufacturing	57	42.5
	Services	79	58.5
Annual allocation of R&D	<50 k	73	57.9
	51 – 100k	25	18.4
	101 – 300 k	13	9.6
	> 300k	15	11.0
Annual Sales Turnover	< 300k	34	32.1
	300k – 5 mil	74	54.4
	5 mil – 15 mil	18	13.2
	> 20 mill	13	9.3

Assessment of the measurement model

In assessing the measurement model, convergent validity which is the degree to which multiple items measuring the same concept are in agreement was tested. As suggested by Hair et al. (2010), the factor loadings, composite reliability and average variance extracted was used to assess convergence validity. The loadings for all items exceeded the recommended value of 0.5 (Hair et al., 2010). Composite reliability values (see Table 2), which depict the degree to which the construct indicators indicate the latent construct ranged from 0.923 to 0.956 which exceeded the recommended value of 0.7 (Hair et al., 2010). The average variance extracted, which reflects the overall amount of variance in the indicators accounted for by the latent construct, were in the range of 0.708 and 0.789 which exceeded the recommended value of 0.5 (Hair et al., 2010). Therefore, the measures of the all the variables/constructs have high levels of convergent validity.

Table 2. Result Of The Measurement Model

Variable	Construct	Loadings	α	CR	AVE
KM	KA	0.759 – 0.901	0.708	0.923	0.708
	KAP	0.844- 0.885	0.751	0.924	0.751
	KC	0.852-0.893	0.772	0.932	0.772
	KD	0.777-0.893	0.719	0.948	0.712
	KP	0.854-0.903	0.768	0.943	0.768
SCA	CL	0.788-0.907	0.851	0.887	0.723
	PD	0.789-0.922	0.872	0.919	0.789
	INVPER	0.789-0.915	0.912	0.938	0.742
IINV		0.832-0.945	0.946	0.956	0.756

Notes: CR- composite reliability; α – Cronbach's alpha; AVE- average variance extracted; KA – Knowledge Acquisition, KAP – Knowledge Accumulation, KC- Knowledge Creation, KD- Knowledge Dissemination, KP- Knowledge Protection; CL – cost leadership; PD – Product Differentiation; INVPer- Innovation Performance; KD4 was deleted due to low loadings.

Discriminant validity of constructs

Discriminant validity is the extent to which the measures is not a reflection of some other variables and is indicated by the low correlations between the

measure of interest and the measures of other constructs (Cheung and Lee, 2010). Discriminant validity can be examined by comparing the squared correlations between constructs and the average variance extracted for a construct (Fornell and Larcker, 1981). As shown in Table 3, the squared correlations for each construct are less than the average variance extracted by the indicators measuring that construct indicating adequate discriminant validity. In total, the measurement model demonstrated the adequate convergent validity and discriminant validity.

Table 3. Discriminant Validity of Constructs

	1	2	3	4	5	6	7	8	9
1 KA	0.70 8								
2 KA P	0.52 0	0.75 1							
3 KC	0.68 1	0.69 9	0.77 2						
4 KD	0.59 9	0.63 3	0.69 7	0.71 2					
5 KP	0.55 8	0.49 4	0.62 2	0.68 0	0.76 8				
6 CL	0.20 6	0.15 5	0.16 8	0.17 6	0.14 4	0.72 2			
7 PD	0.20 1	0.27 1	0.25 5	0.25 7	0.25 6	0.16 4	0.79 2		
8 IPP	0.25 9	0.41 5	0.30 8	0.36 3	0.37 2	0.34 8	0.41 5	0.74 2	
9 INV	0.49 0	0.58 2	0.59 1	0.60 0	0.55 6	0.26 8	0.34 7	0.41 3	0.75 6

Note: Diagonals are the AVE while the off-diagonals are the squared correlations.

Assessment of the Structural Model

Figure 1 represents the structural model results with the coefficients for each path that indicates the causal relations among the constructs in the model (Sang, Lee and Lee, 2010). The tests on the significance of the path and hypothesis in the path model were performed using the SmartPLS's bootstrap re-sampling technique. KM has a weak relationship to SCA (0.307) and has explained variance of 0.094 in SCA. However, KM has a strong indirect relationship with SCA (0.564, $p > 0.01$) where innovative intelligence (IInv) mediates the relationship between KMP and SCA. Together, both KMP and IInv contributed 23.6% of variance explained in SCA. There could be other factors influenced the SCA in SMEs in Malaysia.

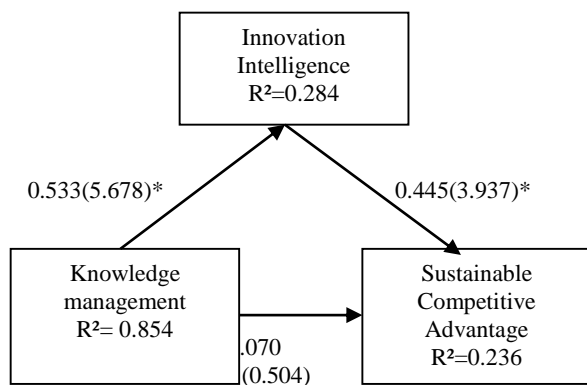

Figure 1. Structural Model

V CONCLUSION

This paper attempts to investigate the relationship of KM and SCA of SMEs. The finding showed that KM has a weak relationship to SCA of SMEs. This finding is similar to Banjo & Doren (2015) knowledge management orientation has not fully utilized by SMEs to leverage their knowledge-based resources. Plessis (2007) found that the difficulty in managing knowledge are faced by organization regardless of size, however, large organizations have more systematic structures and focus. Nevertheless, it has shown that knowledge management is important to help SMEs in gaining its SCA. KM has been used widely in large organizations which KM was proven to contribute to the organizational effectiveness (Nghah et al. 20086). However, KM has not been widely explored in SMEs as SMEs always been perceived too small and not capable of practicing KM. Innovation is extremely dependent on knowledge (Plessis,2007). Knowledge management has a strong relationship to innovation intelligence which is similar to study done by Lee and Choi (2002) where they found a strong relationship between knowledge creation and creativity. This is can be reiterated that the systematic flow of knowledge inside the organization would develop innovative intelligence. Knowledge management has an impact on SCA through innovative intelligence. This finding is similar with Ahmad (2015) who found that KM has an impact on SCA via business intelligence.

Limitations

This study has certain limitations. This study only focuses on SMEs are assumed to be knowledge-intensive. As such, there is still room for further investigation into the adoption of innovation by a more general population. Second, the study was carried out innovation performance as one of the elements of SCA which was never used before. Therefore, the future research should focus on SMEs that involved actively in innovation and technology to generate more accurate findings. Finally, a bigger size of sample and respondents would give better results.

Additionally, the instrument was also self-administered and there could be situations where respondents may need further clarification, which was not available. Finally, this study provides an empirical finding of innovative intelligence which has never been done before. It is interesting to find out the importance of innovative intelligence especially in helping SMEs in sustaining their competitive advantage. In fact, the findings have shown that innovative intelligence has a strong impact on innovation performance which proven that innovative intelligence is important to improve innovation in the organization. Knowledge management is important to SMEs to competitive advantage and improves their innovation capability through innovative intelligence. This study has shown that innovative intelligence exists in SMEs and has been utilized effectively. Thus, the findings have important implications not only for theory but for practice as well.

ACKNOWLEDGEMENTS

The authors would like to thank the Research Management Institute of Universiti Teknologi MARA and the Ministry of Education for supporting and funding this study. This study was awarded a research grant by the Ministry of Education (MOE), Malaysia, under the Fundamentals of Research Grant Scheme (600-RMI/FRGS 5/3 (69/2014)).

REFERENCES

- Ahmad, A. (2015). Sustaining Competitive Advantage via Business Intelligence, Knowledge Management, and System Dynamics. *Advances in Business Marketing & Purchasing*, 22A (1-2).
- Bamberger, I. (1989). Developing competitive advantage', *Long-Range Planning*, 22(5), 27-35
- Banjo, R. & Doren, C. (2015). Knowledge management view of environmental sustainability in manufacturing SMEs in the Philippines. *Journal of Knowledge Management Research and Practices*. DOI 10.1057/kmrp.2015.30
- Barney A (1997). Exploiting organizational knowledge in the learning organization. *Work Study*, 46 (6): 202-206.
- Cheung, C.M.K. and Lee, M.K.O. (2010), A theoretical model of intentional social action in online social networks, *Decision Support Systems*, 49(1), 24-30
- Chin, W. (1998). Issues and opinions on structural equation modeling, *MIS Quarterly*, 22(1),7-16.
- Cavusgil, S.T., Calantone, R.J., Zhao, Y. (2003). Tacit knowledge transfer and firm innovation capability. *Journal of Business & Industrial Marketing*, 18(1), 6-21.
- Chikati,R. & Mpofu, N. (2013). Developing Sustainable Competitive Advantage through Knowledge Management. *International Journal of Scientific & Technology Research*, 2(10), 77 – 81.
- Danet, D. (2006). Competitive Intelligence and SMEs: Small Firms are They Less Intelligent Than the Large Ones? Available at SSRN 875405.
- Darcy, C., Hill, J., McCabe, T., & McGovern, P. (2014). A consideration of organisational sustainability in the SME context. *European Journal of Training and Development*, 38(5), 398-414. doi: 10.1108/ejtd-10-2013-0108.
- Davenport T. H. & Prusak,L. (1998). How Organizations Manage What They Know, Boston, Harvard Business School

- Fornell, C. and Larcker, D.F. (1981), Evaluating structural equation models with unobservable variables and measurement error. *Journal of Marketing Research*. 18(1), 39-50.
- Gao F, Li M, Clarke S (2008). Knowledge, management, and knowledge management in business operations. *Journal of Knowledge Management*. 12(2):3-17.
- Gold A. H., Malhotra A. & Segars, A. H. (2001). Knowledge management: An organisational capabilities perspective. *Journal of Management Information Systems*, 18(1), 185-214.
- Hair, J.F., Black, W.C., Babin, B.J. and Anderson, R.E. (2010), *Multivariate Data Analysis*, Prentice-Hall, Upper Saddle River, NJ.
- Khan, R.A. (2014). Sustainable competitive Advantage through knowledge management. *International Journal of Advanced Research in Computer Engineering & Technology*, 3(4), 1079-1082.
- Lee, H. and Choi, B. (2003). Knowledge Management Enablers. Process and organizational performance; an integrative view and empirical examination. *Journal of Management Information Systems*. 20 1 179-228.
- Mahdi, O.R., Almsafir, M.K. & Yao, L. (2011). The role of knowledge and knowledge management in sustaining competitive advantage within organizations: A review. *African Journal of Business Management*. 5(23), 9912-9931, doi: 10.5897/AJBM11.1118
- Matthews, J. (2003). Knowledge Management and Innovation: How are they related? KM Challenge 2003 Knowledge Management Conference April 24, Melbourne.. Retrieved from <http://eprints.qut.edu.au/14629/1/14629.pdf>.
- Montequin, V.R., Fernandez, F.O., Cabal, V .A. and Gutierrez, N.R. (2006) . An integrated framework for intellectual capital measurement and knowledge management implementation in small and medium-sized enterprises. . *Journal of Knowledge Management* 32(6) 525-538.
- Ngah, R. , Chua, B.H. and Ibrahim, R. (2008). Knowledge management and trust in Auditing firms in Malaysia. *Conference paper in IBIMA 2008*.
- Omotayo, Funmilola Olubunmi, "Knowledge Management as an important tool in Organisational Management: A Review of Literature" (2015). *Library Philosophy and Practice* (e-journal). Paper 1238. <http://digitalcommons.unl.edu/libphilprac/1238>
- Plessis, d.M. (2007). The role of knowledge management in innovation. *Journal of Knowledge Management*, 11(4), 20 – 29. Doi. <http://dx.doi.org/10.1108/13673270710762684>
- Ranggone, A. (1999). A Resource-Based Approach to Strategy Analysis in Small-Medium Sized Enterprises. *Small Business Economics* 12, 233–248.
- Ringle, C.M., Wende, S. and Will, A. (2005), "SmartPLS 2.0 (beta)", available at: www.smartpls.de (accessed April 22, 2016).
- Roberts, N. and Grover, V. (2012), Investigating firm's customer agility and firm performance: the importance of aligning sense and respond capabilities, *Journal of Business Research* , 65(5), 579-585
- Tidd, J & Bessant, J. (2011). *Managing Innovation. Integrating Technological, Market and Organizational Change*. 5th ed. John Wiley & Sons Ltd, Sussex, UK.
- Tenenhaus, M., Vinzi, V.E., Chatelin, Y.M. & Lauro, C. (2005), PLS path modeling, *Computational Statistic and Data Analysis*, 48(1), 159-205.
- Ünay, F. G., & Zehir, C. (2012). Innovation intelligence and entrepreneurship in the fashion industry. *Procedia - Social and Behavioral Sciences*, 41, 315-321. doi: 10.1016/j.sbspro.2012.04.036
- Weiss, D., & Legrand, C. (2011). *Innovative Intelligence* Ontario, Canada: Wiley and Sons.
- Wetzels, M., Schroder, G.O. and Oppen, V.C. (2009), Using PLS path modelling for assessing hierarchical construct models: guidelines and empirical illustration, *MIS Quarterly*, 33(1), 177-95.
- Wu S.E., Lin, L.Y. & Hsu M.Y. (2007). Intellectual Capital, Dynamic Capabilities And Innovative Performance Of Organisations *International Journal of Technology Management*, 39(3-4). Doi: <http://dx.doi.org/10.1504/ijtm.2007.013496>
- Zabid, M.A.R (2000). Business Strategies and Competitive Advantage Factors in the Electronics Industry in Malaysia. *Jurnal Pengurusan*, 19, 27-39.

Behavioral Intention to use Knowledge Sharing Tools: Positive and Negative Affect on Affective Technology Acceptance Model

Angela Lee Siew Hoong and Tong-Ming Lim

Sunway University, Malaysia, {angelal; tongmingl} @sunway.edu.my

ABSTRACT

This study examines the affective aspect of the technology acceptance by extending TAM with positive and negative affect as external construct. This research attempts to study on the Knowledge workers that work in the Multimedia Super Corridor (MSC)-status organizations to understand their behavioral intention to use the knowledge sharing tools (KS tools) in their day-to-day tasks based on several motivators. KS tools in this research includes collaborative and communicative functions such as email, blog and Facebook. This research proposes Affective Technology Acceptance (A.T.A) Model that hypothesizes Positive and Negative Affect (PA and NA) have impact on Perceived Usefulness (PU), Perceived Ease of Use (PEOU) and Behavioral Intention to accept (BI) KS tools among knowledge workers in MSC organizations. Positive Affect (PA) and Negative Affect (NA) are defined as the perception of employees on KS tools that induce positive or negative affective states when they interact and evaluate these tools when execute their tasks.

Keywords: Positive affect, negative affect, TAM, knowledge sharing tools, knowledge workers, Affective Technology Acceptance model

I INTRODUCTION

Knowledge sharing and tools used to share knowledge in organizations have always been viewed essential for decade. Some research works focused on acceptance of ICT whereas some examined behavior in knowledge sharing activities. (Lin & Lee, 2004; Hendriks, 1999) From the emotional dimension, the concepts on affect, mood, and emotions have always used been used interchangeably by researchers. Many inconsistent reports and conflicting findings from past studies that consider affect have resulted in very small number of research undertakings in this area. However, research has shown that reflexes, social judgment, perception, and behavior (Russell, 2003; Forgas and George, 2001) are influenced by affect, mood and emotion which constitute the fundamental aspects of human beings. Study on the impact of affect on job performance (Weiss, Nicholas and Daus, 1999), decision making behavior (Childers, Carr, Peck and Carson, 2001), and attitude change or

persuasion (Petty, DeSteno and Rucker, 2001) are some of the works found in the areas of organizational behavior, marketing, social psychology and management. Deep review on the influence of affect on assessment, memory, performance and attention was also carried out (Brave and Nass, 2003). In the recent works reviewed, emotional dimension has started to attract more attention from researchers in the domain of technology acceptance.

In the Information Systems (IS) domain, user evaluation or user acceptance of Information Technology (IT) is considered as volitional behavior (Bagozzi 1982) and has been studied primarily with a cognitive orientation (Davis 1989; Goodhue 1995; Venkatesh, Morris, Davis and Davis 2003). Research in this area has always been heavily influenced by the cognition-attitude-behavior models such as Theory of Reasoned Action and the Theory of Planned Behavior (Ajzen and Fishbein 1980; Fishbein and Ajzen 1975). Even though some works on affect, affectivity, playfulness, enjoyment and emotion have been studied, the affective aspects are less central in most of these studies, with some exceptions, such as studies on emotional usability (Kim, Lee and Choi 2003), aesthetics (Lavie and Tractinsky 2004; Tractinsky, Katz and Ikar 2000), computer playfulness (Webster and Martocchio 1992), flow (Finneran and Zhang 2003; Ghani 1995), and users' holistic experiences of cognitive absorption in technology acceptance (Agarwal and Karahanna 2000). Even when some affective constructs are studied, other important constructs escape scrutiny, and researchers fail to agree on definitions.

Due to these limitations of many current studies, the goals of this paper is to investigate whether affect plays a role in an individual's evaluation, reaction, acceptance and use of IT in different contexts for various purposes. Further, if affect does indeed play a role, the expected outcomes of the research will be able to answer the following questions: what aspects of affect should it be examined; what relationships affect may have with other commonly studied user acceptance constructs; whether the role of affect is due to novelty or short-lived impression or persists over time; and how to design affect-friendly systems that will be more beneficial to users.

II RELATED WORKS

In TAM (Figure 1), the Intention to use is the main determinant of usage behaviour to accept or not to accept a new technology. The Intention to use is determined by the person's attitude toward using a particular technology. Perceived Usefulness and Perceived Ease of Use influence an individual's attitude toward using a particular technology. Perceived Usefulness (PU) is defined as the degree to which a person believes that using a particular system would enhance his or her job performance (Davis, 1989). PU is the key determinant that positively affects users' beliefs and intention to use the technology. Perceived Ease of Use (PEOU) is defined as the degree to which the user uses a particular system is free of effort (Davis, 1989). Past research have shown that Perceived Ease of Use (PEOU) influences intention in two ways: direct and indirect effect through perceived usefulness (Davis, 1989). According to Davis (1989), PEOU has no significant influence on behavioral intention to use because PU mediated its influence. The PEOU does not impact directly on user's behavioral intention because it has an effect on behavioral intention through PU. If users do not have perceptions on the usefulness of new technology, PEOU will not have any effect on intentions.

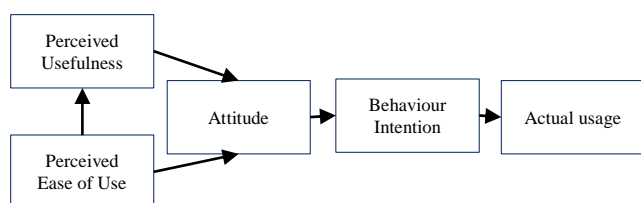

Figure 1. Technology Acceptance Model

All social sciences share a pursuit to try to explain and predict individual's behaviours where these behaviours are influenced by both cognitive processes and emotional or affective markers. Most behavioral theories ignore and sideline role of affect due to affective related factors in user technology acceptance are less consistent, clear and conclusive from both theoretical and empirical perspectives. Affect can range from very specific and acute emotions such as anger or fear; to broader and longer term moods such as cheerfulness and depression. Affect refers to one's feeling state or how one feels when performing some tasks (George and Jones, 1996; Loiacono and Djasasbi, 2010). Affect is also defined as one's moods and emotions (Fredrickson, 2003). Russell (2003), Fredrickson (2003), Lazarus (1991), Moore and Isen (1990) refer to affect as mood, emotion, and feelings. Bagozzi *et al.* (1999) and Liljander *et al.* (2002) said that affect is conceived as an umbrella concept for a set of specific mental processes which

includes emotions, moods and attitudes. Meanwhile, Kelly and Barsade (2001) group affect into five general factors that form different types of affect structure. These are dispositional affect, mood, acute emotions, emotional intelligence and sentiments.

Zhang and Li (2007) investigated the impacts of affective evaluations of IT on IT use decisions. In their work, two object-based affective evaluation constructs: perception on IT's capability to induce positive affect (PC-PA) and perception of the IT's capability to induce negative affect (PC-NA). Their study showed that PC-PA and PC-NA are distinct concepts that have different effects on perceived usefulness (PU), perceived ease of use (PEOU), and attitude toward using the IT (ATB). These effects hold true during both initial use and continued use. PC-PA influences PU, PEOU and ATB but becomes less important to PU over time, and PC-NA only influences PEOU but becomes more important to PEOU over time. In this study, they focus on affective evaluations and their impacts. Zhang and Li (2007) concluded that affect plays an important role in the user interactions with IT.

III PROPOSED AFFECTIVE TECHNOLOGY ACCEPTANCE (A.T.A) MODEL

In this research, PA and NA are defined as the perception on KS tools' characteristics in terms of features and functions to induce positive or negative affective states (Zhang and Li, 2007; Zhang, 2013). PA and NA were adapted from Zhang and Li (2007) where they defined PA and NA as the perception of an IT's Capability to induce positive or negative affect. It is an individual's perception or evaluation that an IT has the features and functions to induce positive or negative affect in him or her. In this study, the external stimulus is KS tools used by the knowledge workers in the MSC-status organizations in Malaysia. The respondents were asked to indicate the extent of how he/she feels on the usefulness, ease of use and intention to use the KS tools in eight (8) different point in times in the instrument. The adopted PANAS scale (Watson and Tellegen, 1985) is to capture a respondent's affective state by reflecting how one feels back in time to observe the influence of affect on one's behaviour. The different affective states of the knowledge workers were self-reported on the survey form. The measurement scale for PA and NA is adopted from Technology Affect Scale (Perlusz, 2004) where Perlusz (2004) adapted the 10-item scale from Watson and Tellegen (1985). The scale was validated using two groups of undergraduate students who were exposed to different types of affects before interacting with mobile

technologies. The Technology Affect Scale is found to be consistent and valid in his experiments.

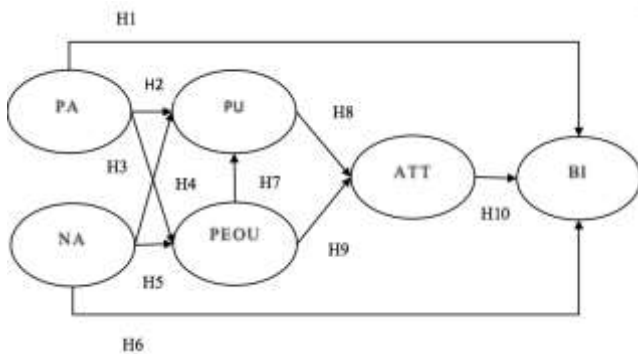

Figure 2.: Affective Technology Acceptance Model

Figure 2 exhibits the proposed model hypothesized that the perceived KS tools' affective quality can induce PA and NA that is able to influence the intention to use and accept the tools.

- H1: PA will have positive effect on BI
- H2: PA will have positive effect on PU
- H3: PA will have positive effect on PEOU
- H4: NA will have negative effect on PU
- H5: NA will negative effect on PEOU
- H6: NA will have negative effect on BI
- H7: PEOU will have positive effect on PU
- H8: PU will have positive effect on ATT
- H9: PEOU will have positive effect on ATT
- H10: ATT will have positive effect on BI

IV RESEARCH METHODOLOGY

The target population for this research is the knowledge workers from MSC-status organizations in Malaysia. The knowledge workers in this samples are anyone who works for living on the tasks that primarily deal with information or require to develop and use knowledge to solve problems. About 2500 MSC-status organizations from the MSC directory(http://www.mscomalaysia.my/company_directory) are invited to participate in this research. Invitations were sent out to these organizations and from the organizations that accepted the invitation, a total of 2505 survey forms were distributed, 302 forms were received and 295 of them were usable forms. From the self-administered questionnaire received, a response rate of 11.87% was achieved. Seven (7) survey forms were discarded because the respondents did not respond 80% of the questions on the survey form. This study uses stratify sampling approach. The respondents evaluate a list of knowledge sharing tools (KS tools) that they use in their day-to-day activities for tasks given to them

V ANALYSIS OF RESULTS

The proposed model and hypothesis testing was conducted using partial lease squares (PLS) software: SmartPLS 3.0. The analysis carried out in this paper follow strictly Hair et al. (2012) on the measurement model and structural model of the A.T.A research model in this research. In this research, a sample size of 295 is sufficient to simultaneously examine the predictive accuracy of constructs and path coefficients of relationships in the models. This section analyzes measurement model that consists of reflective and formative models.

Reflective constructs in the proposed model are Perceived Usefulness (PU_I), Perceived Ease of Use (PEOU_H), Attribute toward use of KS tools (ATT_G), and Behavioural intention to use KS tools (BI_J). Composite reliability varies between 0 and 1 with higher values indicating higher levels of reliability. Composite reliability of 0.60 - 0.70 is acceptable while values between 0.70 – 0.90 can be regarded as satisfactory (Nunally and Bernstein, 1994). However, if composite reliability (Table 1) has a value higher than 0.95, this indicates that all indicators are measuring same phenomenon of a construct and therefore unlikely to be a valid measure of the construct.

Table 1. Composite reliability

Constructs	Composite reliability (CR)
Perceived Usefulness (PU_I)	0.95
Perceived Ease of Use (PEOU_H)	0.93
Attitude toward use of KS tools (ATT_G)	0.93
Behavioral Intention to use KS tools (BI_J)	0.94

Discriminant validity is the extent to which a construct is truly distinct from other constructs by empirical standards. This means a construct is unique and captures phenomena not represented by other constructs in a model. In Table 2, Average Variance Extracted (AVE) are examined. Two measures of discriminant validity are used in the analysis; they are Cross loading and Fornell-Larcker criterion.

Table 2. Average Variance Extracted (AVE)

Constructs	AVE
PU_I	0.71
PEOU_H	0.59
ATT_G	0.64
BI_J	0.68

Table 3 exhibits discriminant validity for reflective constructs. The results indicate that all constructs' AVE have high correlation compared to others. Thus, the results fulfilled the Fornell-Larcker discriminant validity.

Table 3. Discriminant Validity

Reflective Constructs	ATT_G	BI_J	PU_I	PEOU_H
ATT_G	0.799			
BI_J	0.717	0.826		
PU_I	0.756	0.717	0.843	
PEOU_H	0.601	0.506	0.545	0.782

The significance of relationships is examined next. An analysis of the relative importance of relationships is crucial for interpreting the results and drawing conclusions. If path coefficient is larger than the other path on a dependent construct, its effect on the endogenous latent variable is greater. These coefficients represent the estimated change in the endogenous construct for a unit of change in the exogenous construct. As for effects, direct effect is the effect of one construct on another one. Indirect effect is the effect of one construct on another construct via one or more mediating constructs. Total effect is the sum of direct and indirect effects. If a path is significant, the hypothesis is supported which indicate that responses provide significant support to the hypothesis. In the analysis, it is found that one (1) hypothesis is not being supported (Table 4).

Table 4. Hypothesis Testing Decision

Path	Decision
ATT_G -> BI_J	Supported
NA_BI -> BI_J	Supported
NA_PEOU -> PEOU_H	Supported
NA_PU -> PU_I	Not Supported
PA_BI -> BI_J	Supported
PA_PEOU -> PEOU_H	Supported
PA_PU -> PU_I	Supported
PU_I -> ATT_G	Supported
PEOU_H -> ATT_G	Supported
PEOU_H -> PU_I	Supported

VI DISCUSSION

KS tools have been grouped into several major groups for the analysis purposes. In the demographics analysis, several observations have been found. From the aspect of KS tools usage, KS tools that have low usage frequency include Social Media, Web Meeting, Digital Repository, and Messaging System. Many related works reviewed from the past indicated that Web 2.0 technology and systems have been very successfully to provide knowledge sharing capability.

However, this was not found in the study. However, KS tools that have high usage frequency such as Discussion Forum was found to have attracted a lot of knowledge workers. A close examination found that Email is the most extensively used KS tools in the MSC-status organizations to communicate and collaborate.

In the outcomes of the formative construct analysis, PA and NA for PU, PEOU and BI satisfy all the tests as according to Hair et al (2012). Only an item that measures NA for PEOU was found to be not significant. However, based on the instrument adapted, the NA item was retained.

In the hypothesis testing, a total of ten (10) paths have been tested. The data collected supported nine (9) of the ten (10) paths in the proposed model. Only one (1) path was not been supported: NA_PU -> PU_I deduce that negative affect has no impact on Perceived Usefulness of KS tools. This contrast to the findings in the existing works. Zhang and Li (2007) stated that negative affective state has more apparent and easier to measure as compare to positive affect element in many studies. And negative affect always impacts the performance of the knowledge workers and usage of a technology. However, the outcome of this research produces a new finding where it states that negative affect does not impact the Perceived Usefulness of the KS tools. This can be deduced by conclude that when KS tools are perceived to be useful, they remain useful regardless of the affective state of an individual at that point of time.

As for constructs in TAM, the outcomes align to many past research works presented by Davis (Davis, 1989) and Vankatesh (Venkatesh et al., 2003). The findings from the research model can be concluded that Attitude toward KS tools usage has strong influence on Behavioural Intention Usage of KS tools. Perceived Usefulness of KS tools strongly influence the Attitude of the knowledge workers to use the tools. Perceived Ease of Use has positive influence on the Attitude of knowledge workers on the tools usage. And Perceived Ease of Use has strong positive impact on Perceived Usefulness of KS tools. As for PA and NA, they are hypothesized to have either negative or positive impact on PU, PEOU and BI in the A.T.A model.

In the Affective Technology Acceptance Model (A.T.A), Negative Affect has strong impact on Behavioural Intention Usage of KS tools. As knowledge workers use the KS tools to do their day-to-day jobs, this is the extent of they feel after interacting and using these tools provided to them. This could derive that if a tool has strong negative influences on BI, it will deter or slow down the widespread of the tools among the knowledge workers in the organizations. Negative affect also has strong negative influence on PEOU and PU of the KS

tools too. It is apparent that knowledge workers view negative affect is an important element where such negative element can impact on the Behavioural Intention of KS tools usage.

The Positive Affect is hypothesized to have positive impact on PEOU, PU and BI. In the outcomes of the analysis, PA has been found to have positive significant influence on these three (3) constructs. The business operators have to maximize the positive affect to influence the PEOU, PU and BI of the KS tools since the outcomes of the analysis highlight that such positive affective state can help to improve and increase the intention of the knowledge workers to use the KS tools.

Table 5. Path Coefficient

Hypothesis	Path coefficient	t value	P value
ATT_G -> BI_J	0.40	6.05	0.00
NA_BI -> BI_J	-0.10	2.03	0.04
NA_PEOU -> PEOU_H	-0.14	2.30	0.02
NA_PU -> PU_I	-0.07	0.95	0.34
PA_BI -> BI_J	0.13	2.77	0.01
PA_PEOU -> PEOU_H	0.23	4.47	0.00
PA_PU -> PU_I	0.10	1.84	0.07
PU_I -> ATT_G	0.61	15.00	0.00
PEOU_H -> ATT_G	0.27	5.53	0.00
PEOU_H -> PU_I	0.32	4.34	0.00

From the predictive capability of the constructs, Attitude and Behavioural Intention of KS tools usage are the strongest among other constructs. This is followed by PU and PEOU of KS Tools. PU can predict as accurate as 45% of the usefulness of the tools whereas PEOU can predict as much as 36% of the KS tools' ease of use (Table 5). This means that antecedents for PU and PEOU, PA and NA, as external factors for TAM model, are very important. The stronger PA is, the more likely that the positive affect is able to help improving their attitude hence result in stronger intention to use the tools.

VII CONCLUSION

As a conclusion, this research has highlighted that positive and negative affect in the view of the knowledge workers can either negatively or positively influence the Behavioural Intention usage of KS tools in the MSC-status organizations. As business operators are able to maximize the positive energy and minimize the negative energy among the

knowledge workers, the stronger their behavioural intention to use KS tools will be.

A number of future research topics that can be considered include knowledge workers in SME on various industries. Next, different new knowledge sharing tools used by knowledge workers can be used to be tested on A.T.A model in order to validate and improve the model.

REFERENCES

- Agarwal, R., & Karahanna, E. (2000) Time Flies When You're Having Fun: Cognitive Absorption and Beliefs About Information Technology Usage, *MIS Quarterly* (24:2), pp. 665-694.
- Bagozzi, R.P. (1982) A field investigation of causal relations among cognitions, affect, intentions and behavior, *Journal of Marketing Research* (10), November 1982, pp 562-584.
- Bagozzi, R. P., Gopinath, M., & Nyer, P. U. (1999). The role of emotions in marketing. *Journal of the academy of marketing science*, 27(2), 184-206.
- Beaudry, A., & Pinsonneault, A. (2005). Understanding user responses to information technology: A coping model of user adaptation. *MIS quarterly*, 493-524.
- Brave, S., & Nass, C. (2003) Emotion in Human-Computer Interaction, in: *The Human-Computer Interaction Handbook*, J. Jacko and Childers, T.L., Carr, C.L., Peck, J., & Carson, S. (2001) Hedonic and utilitarian motivations for online retail shopping behavior, *Journal of Retailing* (77:4) 2001, pp 511-535.
- Davis, F. (1989) Perceived Usefulness, Perceived Ease of Use, and User Acceptance of Information Technology, *MIS Quarterly* (13:3), September 1989, pp 319-340.
- Finneran, C.M., & Zhang, P. (2003) A person-artefact-task (PAT) model of flow antecedents in computer mediated environments, *International Journal of Human-Computer Studies* (59:4), 10 2003, pp 475-496.
- Forgas, J.P. & George, J.M. (2001) Affective Influences on Judgments and Behavior in Organizations: An Information Processing Perspective," *Organizational Behavior and Human Decision Processes* (86:1), 9 2001, pp 3-34.
- Fredrickson, B. L. (2003) Positive emotions and upward spirals in organizations. In K. S. Cameron, J. E. Dutton, & R. E. Quinn (Eds.), *Positive organizational scholarship: Foundations of a new discipline* (pp. 163-175). San Francisco, CA: Berrett-Koehler.
- Frijda, N. H. (1986). *The emotions: Studies in emotion and social interaction*. Edition de la.
- Frijda, N. H. (1994). Emotions are functional, most of the time.
- George, J. M., & Jones, G. R. (1996). The experience of work and turnover intentions: interactive effects of value attainment, job satisfaction, and positive mood. *Journal of Applied Psychology*, 81(3), 318.
- Ghani, J. (1995) Flow in human computer interactions: test of a model, in: *Human Factors in Information Systems: Emerging Theoretical Goodhue, D. L. (1995) Understanding User Evaluations of Information Systems, Management Science* (41:12), December 1995, pp. 1827-1844.
- Hendriks, P. (1999). Why share knowledge? The influence of ICT on the motivation for knowledge sharing. *Knowledge and process management*, 6(2), 91.
- Kelly, J. R., & Barsade, S. G. (2001). Mood and emotions in small groups and work teams. *Organizational behavior and human decision processes*, 86(1), 99-130.
- Kim, J., Lee, J., & Choi, D. (2003) Designing emotionally evocative homepages: an empirical study of the quantitative relations between design factors and emotional dimensions, *International Journal of Human-Computer Studies* (59:6), 12 2003, pp 899-940.
- Lazarus, R. S. (1991). Progress on a cognitive-motivational-relational theory of emotion. *American psychologist*, 46(8), 819.
- Lavie, T., & Tractinsky, N. (2004) Assessing dimensions of perceived visual aesthetics of web sites, *International Journal of Human-Computer Studies* (In Press, Corrected Proof) 2004.

- Liljander, V., & Roos, I. (2002). Customer-relationship levels-from spurious to true relationships. *Journal of services marketing*, 16(7), 593-614.
- Lin, H. F., & Lee, G. G. (2004). Perceptions of senior managers toward knowledge-sharing behaviour. *Management decision*, 42(1), 108-125.
- Loiacono, E. & Djasasbi, S. (2010) Moods and Their Relevance to Systems Usage Models within Organizations: An Extended Framework. AIS Transaction on Human-Computer Interaction, pp. 55-72.
- Moore, G. C., & Benbasat, I. (1991). Development of an instrument to measure the perceptions of adopting an information technology innovation. *Information systems research*, 2(3), pp 192-222.
- Moore, B. S., & Isen, A. M. (1990). *Affect and social behavior*. Cambridge University Press.
- Mulligan, K., & Scherer, K. R. (2012). Toward a working definition of emotion. *Emotion Review*, 4(4), 345-357.
- Nunnally, J. C., & Bernstein, I. H. (1994). *Psychometric theory*. New York.
- Perlusz, S. (2004, October). Emotions and technology acceptance: development and validation of a technology affect scale. In *Engineering Management Conference, 2004. Proceedings. 2004 IEEE International* (Vol. 2, pp. 845-847). IEEE.
- Russell J.A. (2003) Core affect and the psychological construction of emotion. *Psychol Rev*. 2003 Jan;110(1):145-72.
- Tractinsky, N., Katz, A.S., & Ikar, D. (2000) What is beautiful is usable, *Interacting with Computers* (13) 2000, pp 127-145.
- Venkatesh, V., & Davis, F. D. (2000). A theoretical extension of the technology acceptance model: Four longitudinal field studies. *Management science*, 46(2), pp 186-204.
- Venkatesh, V., Morris, M.G., Davis, G.B., & Davis, F.D. (2003) User Acceptance of Information Technology:Toward a Unified View, *MIS Quarterly* (27:3), September 2003, pp 425-478.
- Webster, J., & Martocchio, J.J. (1992) Microcomputer playfulness: development of a measure with workplace implications, *MIS Quarterly* (16:1) 1992.
- Weiss, H.M., Nicholas, J.P., & Daus, C.S. (1999) An Examination of the Joint Effects of Affective Experiences and Job Beliefs on Job Satisfaction and Variations in Affective Experiences over Time, *Organizational Behavior and Human Decision Processes* (78:1), 4 1999, pp 1-24.
- Zhang, P. & Li, N. (2004) Love at First Sight or Sustained Effect? The Role of Perceived Affective Quality on Users' Cognitive Reactions toward IT, 25th International Conference on Information Systems, Washington D. C., 2004.
- Zhang, P. & Li, N. (2007) Positive and Negative Affect in IT Evaluation: A Longitudinal Study, Proceedings of the Sixth Annual Workshop on HCI Research in MIS, Montreal, December 8, 2007, pp. 67-71.
- Zhang, P. (2013) The affective response model: a theoretical framework of affective concepts and their relationships in the ICT context, *Journal MIS Quarterly* Volume 37 Issue 1, March 2013 pp. 247-274.

A KM-driven Formative Assessment Framework to Problem-Solving for Law Academics Teaching First Year Non-Law Students

Kanchana Chandran¹, Sanath Sukumaran², and Kalpana Chandran³

¹*Sunway University, Malaysia, kanchanac@sunway.edu.my*

²*Taylor's University, Malaysia, sanath.sukumaran@taylors.edu.my*

³*Hogan Lovells International LLP, United Kingdom, kalpana.chandran@hoganlovells.com*

ABSTRACT

This conceptual paper discusses the need for Knowledge Management (KM) intervention in strategising formative assessment for non-law students studying law. It proposes a unique approach through formative assessment to tailor an effective response to the challenges faced by law academics teaching first year non-law students. The research culminates with a formative assessment framework hereafter referred to as KM-IRAC. The conceptual framework embodies tenets of KM manifested in two distinct stages, Stage 1 being the IRAC equation to problem-solving and Stage 2 being the critical elements of authentic assessment. Both stages 1 and 2 are aimed at assisting and providing law academics with a toolkit in teaching first year non-law students.

Keywords: Knowledge Management (KM), formative assessment, problem-solving, first year non-law students.

I BACKGROUND

Generally, the impression non-law students have in studying law for the first time is that they come with this perception that law is a domain that is beyond their scope to even comprehend, somewhat like learning a foreign language. It is never easy to pick up a foreign language. More often than not, this perception is passed on from seniors to juniors as they tend to believe that the subject is heavy-going with a huge amount of facts to remember. Especially for the students coming from the accounting and finance background who are more interested in figures rather than facts, the volume in itself weighs them down. With this mental block already formed in their mind, it is an uphill task to reverse this notion and get them interested in the subject. When interest is lost, all is lost. It feels more like a burden than a pleasure to study law.

Unlike non-law students, law students have a genuine liking for the subject. Unfortunately, the same does not apply to non-law students who are forced to study law as part of their degree as they do not have the same interest (Owens & Wex

2010). These students also fail to understand the importance of this subject to their profession. As educators, we must have realistic expectations with regards to non-law students studying law in terms of assimilation of legal terms and the required mindset commonly expected of a typical law student. Students are always wanting their learning to be made easy by giving good examples related to the subject and by guiding them on how to answer questions. It is on this note that the researcher feels that something can be done to make it easier for these students to acquire an interest in the subject by creating learning opportunities that are closely connected to their vocation through problem-solving. The objective of the paper is to formulate a KM-driven formative assessment framework for law academics teaching first year non-law students albeit limited to problem-based learning.

II LITERATURE REVIEW

A. Teaching Law

The scope of this research focuses on planning and creating a problem-based formative assessment for first year non-law students studying law. Hence, it is imperative that adequate attention is placed towards understanding the intricacies involved in teaching law from the perspective of content (knowledge), skills development and practice (problem-solving). The ensuing discussion will focus on best practices availed from the literature that can be infused in the teaching and learning of law particularly with regards to problem-based formative assessment.

In teaching law, both knowledge and skills are necessary, as illustrated in Figure 1 below. For the transfer of knowledge to take place, it necessitates construction of meaning and understanding by the learners of the material. The transfer of knowledge revolves around the contents of a subject whereas the development of skills requires the use of knowledge in order to solve a given problem. Therefore it is important to have problem-based learning which facilitates learning either on one's own or through teamwork where students are able

to learn about the subject on their own or by supporting each other in applying their knowledge and skills to solve a problem. An interesting view of the same was espoused by Bloxham and West, 2007. They argued that for there to be engagement with the material, a single act of reading can in no way suffice. They advocated that repeated exposure to the material is paramount and central to understanding and engagement. On the same token, for the development of skills in problem-solving, practice over time is required (Walker & Hobson 2014). Research has also shown that problem-solving is a commonly used approach in teaching first year law students (Braye, Preston-Shoot & John 2005; Claydon 2009).

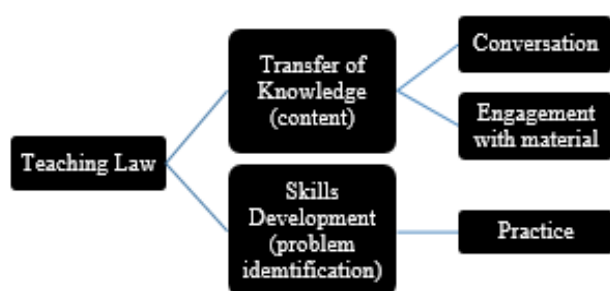

Figure 8. Tools for Teaching Law (adapted from Walker & Hobson 2014)

White (2005) outlined a four step equation which is simple enough for even first year non-law students to use as a guide for answering problem-based questions as illustrated in Figure 2 below.

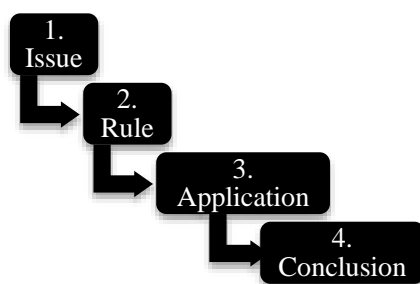

Figure 9. The IRAC Equation to Problem Solving (adapted from Nancy J. White 2005)

Problem solving can be reduced to an easily understood legal equation with IRAC which denotes:

- Issue:** What are the facts in dispute between the parties?
- Rule:** What is the law relevant to the facts in issue?
- Application:** Apply the law to the specific facts
- Conclusion:** Solve the problem

Other authors like Neidwieck was in support of the use of IRAC particularly in the realm of teaching and learning law. In the words of Neidwiecki (2006), “the IRAC is a good model for first year law students” as it helps them organize an answer to a problem-based question.

B. Assessment

In planning the formative assessment framework, Nancy’s approach discussed earlier is a useful guide for non-law students in relation to problem-based learning.

Assessment is about making judgments on the quality of a student’s performance (Knight 2006). Other authors have expanded on this idea to add that an assessment can be used to summarise a student’s achievement to award some form of certification or graded marks – referred to as summative assessment. Conversely unlike summative assessment, formative assessment is not aimed at formal grading but is set out to provide learners with timely feedback that can help in their learning (Falchikov 2005; Sadler 1989; Yorke 2003).

Other authors like Boud & Molloy (2012) have dwelled on the subject of assessment to great length. They summed up saying that the educative purpose of assessment is only achieved when students are capable of producing work that meets the standards as well as making their own judgment about the processes involved in producing the work itself. Hence, weighing on their viewpoints, it is therefore imperative that an assessment – be it formative or summative must be conscientiously tailored to meet the aforementioned aim.

Moving forward, it is important to examine elements of what would constitute authentic assessment. This is best explained by the works of Ashford-Rowe, Herrington & Brown (2014) as depicted in Figure 3.

In a nutshell, it entails the following:

- Demonstrate knowledge and skills: Problem-based learning is aimed at engaging students to use both knowledge of the law and skills in applying the law to solve a problem.
- Transferable: Students should be able to re-apply the knowledge and skills they learn from one area of discipline to a different discipline altogether.

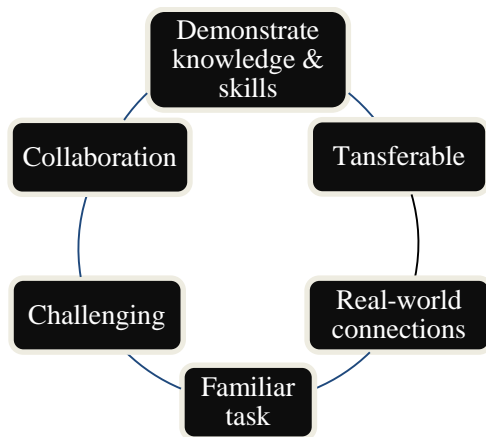

Figure 10. Critical Elements of Authentic Assessment

- Real-world connections: Students should be able to correlate the subject with relevant examples related to their daily lives.
- Familiar task: The task assigned should be a familiar one where students get a flavour of the actual challenge.
- Challenging: The task assigned should offer a challenge in testing one's ability to use the knowledge to solve a given problem.
- Collaboration: Students should be able to learn about a topic in law either on their own or by supporting each other in solving a problem.

C. Knowledge Management

Knowledge Management (KM) can be used as an alternative strategy by universities and higher education institutions to help its academic to be equipped with relevant skills and knowledge to boost learners' core competencies. However, little research has been undertaken on how KM can be applied within the academic setting let alone in teaching and learning law. Since academic staffs are key players in the knowledge creation (Nonaka & Takeuchi, 1995) process, it is imperative that the framework addresses this aspect of importance. This is compounded by the fact that key perspectives of Knowledge Management revolves around dissemination and transfer, acquisition and learning and application (Rodrigues & Pai, 2005). Hence it is imperative that measures to boost quality of teaching and learning ought to revolve around the aforementioned key perspectives.

Figure 4 explains the conceptual framework by showing the link between the KM-IRAC equation in Stage 1 and the critical elements of authentic assessment in Stage 2.

III CONCEPTUAL FRAMEWORK

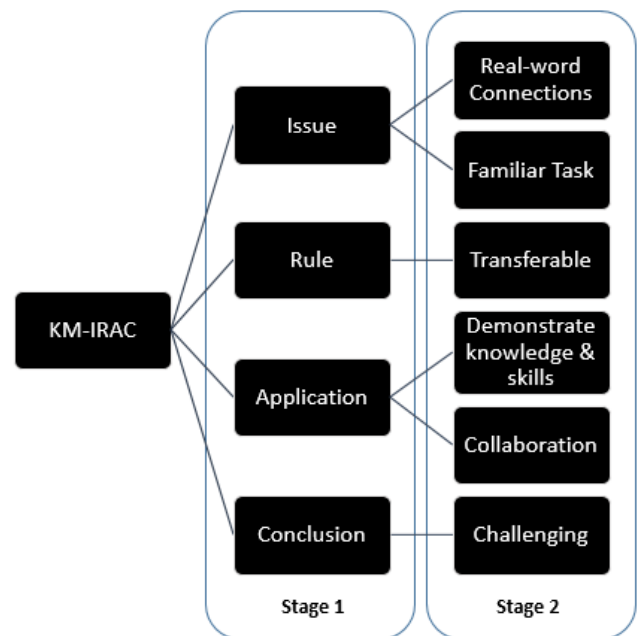

Figure 4. Proposed KM-IRAC Conceptual Framework

A discussion of how this is undertaken is provided herewith:

Issue (Stage 1)

The first IRAC equation on 'Issue' involves:

- The law academic aligning the formative problem-based assessment with the subject (module) learning outcome;
- Identifying the issue between the parties that needs to be solved. This is always in the form of a question. Example: Can X sue Y for breach of contract? There may be more than one issue between the parties; and
- Structuring the question in a chronological sequence of events according to date and time. This is important for a systematic logical flow to be established for the parties involved. The implication of this is far reaching, for instance if this were to be taken to court, the chronological order is of paramount importance.

The law academic must ensure that the case study incorporates real-world connections (Stage 2) with relevant examples related to their daily lives. Along with connecting the formative problem-based assessment to the real world, students should also be familiar with the kind of task (Stage 2) that they may be asked in the actual assessment.

Rule (Stage 1)

The second IRAC equation on 'Rule' involves stating the relevant rule of law to the issue at hand.

An example of a rule of law would be that ‘A contract is formed if there is (i), (ii) and (iii)’. At times there may be more than one rule of law that is applicable to a particular issue. Additionally, students must be made aware that the rule of law must be supported with an Act and/or case law and this must be mentioned in their discussion.

The academic law staff must make this known so that students are vigilant and aware that an issue may have one or more law related implications in real-life contexts. Basically, students should be able to use the knowledge and skills acquired for their present and future life/work opportunities where such knowledge and skills developed can be transferred/used in any field (Stage 2).

Application (Stage 1)

The third IRAC equation on ‘Application’ involves applying the relevant law to the facts of the case study. Students must reconcile these facts to satisfy the rule of law and the issue at hand. For instance, students must be able to give arguments why the facts satisfy or does not satisfy the rule(s) of law. In doing so, the student must be able to make sense of the law in establishing whether the facts of the case study has led to the formation of a contract or otherwise.

It is imperative that the law academic award marks by taking into account both sides of the argument. In facilitating a problem-based learning, students can either work on their own or through teamwork, apply their knowledge and skills (Stage 2) to solve the problem.

Conclusion (Stage 1)

The fourth and final IRAC equation on ‘Conclusion’ involves a closure by providing answers to the issue. For example: X can sue Y for breach of contract. Students must be aware of the far-reaching implications of this statement and the follow-up actions that can take place as a result of this conclusion in order for the party to be advised accordingly.

The law academic must ensure that the conclusion co-relates to the issue, rule and the application of facts in the case study. It is the culmination of all four steps in the IRAC approach that forms the basis of awarding marks. The assigned problem-based assessment should offer a challenge (Stage 2) in testing the students’ ability to use the IRAC equation in problem-solving

IV PILOTING THE KM-IRAC FRAMEWORK

Demographics of the Pilot Group:

The KM-IRAC framework was piloted with a group of 23 students undertaking the module “Business and Hospitality Law”. These students will eventually progress to degree in the field of Culinary Management and International Hospitality Management. The primary focus of this module is to introduce the participants to selected areas of law that are fundamental to the hospitality industry, and give the participants an appreciation of how the law and legal principles relate to the hospitality industry.

Lesson: Tutorial

Topic: Negligence

Learning Outcome:

To explain and apply the legal principles in negligence.

Prior Knowledge/Coverage:

Negligence (covered during lecture)

Case Study:

Mr Loke was driving his Peugeot 508 when it knocked into Mrs Mandy, a pedestrian, who was walking across the road. Mrs Mandy could have easily seen Mr. Loke’s car approaching but she was busy texting on her mobile. Mr. Loke saw Mrs Mandy walking across the road but he was so excited with his car that he did not brake on time. Neither Mr. Loke nor Mrs Mandy took any precautionary measures. Advise Mrs Mandy whether she can succeed in suing Mr Loke in an action based on negligence.

Instruction to Students:

- *The problem-based question should be attempted in groups of 3-5.*
- *You are expected to post your answers on Padlet® by using the IRAC approach.*
- *Padlet® link:
<http://padlet.com/kanchana/negligence>*

Stage 1

The researcher has included an example of how a formative assessment tutorial was tailored using the IRAC structure with the pilot group. A detailed breakdown of how IRAC was used to good effect with the pilot group under Stage 1 of the proposed framework is explained in the table shown in Appendix A. This breakdown is consistent with the explanation in Section IV of this paper.

Stage 2

Padlet® was used to engage in student collaboration where students could express their thoughts on a virtual wall (a common platform) from any device including their mobile phones (Stage 2). Here students were required to map real-world connections by engaging in familiar task and transferring knowledge learnt (negligence in this case). Students were also required to engage in collaborative work and challenged to demonstrate application of knowledge and skills acquired in the process.

The outcome of this exercise is shown here: <http://padlet.com/kanchana/IRAC>

V DISCUSSION

It is important to emphasise the settings or environment where the KM-IRAC framework would exhibit its most impact. It is obvious due to the structure of IRAC (Stage 1) that it works best for only problem-based questions or case based scenarios. Essay questions are generally obvious and relatively straightforward as it focuses only on the rule of law and the explanations of the law.

A problem-based question, on the other hand, involves a hypothetical set of facts which creates issues that need to be addressed by reference to the relevant law in advising a party. Critics however, may argue that there is no stopping in using the IRAC approach in essay-based questions as well, as the discussion of the rule of law or case law can still revolve around the IRAC approach. It must be said however, that the benefits of the KM-IRAC framework is fully realised when Stage 1 is applied in coherence with Stage 2 as shown in the outcome of the pilot study.

Finally, given that the proposed framework is conceptual in nature, there exists the need to further evaluate the framework with other higher education institutions and across different cohorts and academic settings.

VI CONCLUSION

This research discusses challenges and obstacles encountered when teaching law to students from non-legal backgrounds. It is evident that a theoretical framework is necessary to meet the challenges highlighted in the research. The KM-IRAC framework caters for problem based formative assessment and it encapsulates two distinct stages. The first stage being the IRAC equation and the second stage being the critical elements of authentic assessment.

The paper infuses a KM approach in structuring the KM-IRAC framework. The KM-IRAC framework is essentially a toolkit for law academic to devise an effective problem based formative assessment. This is a paradigm shift that law academics must embrace in their quest towards making law relevant towards non-law students. It is hoped that the proposed KM-IRAC framework will be a game changer and influence the preparation of formative assessment amongst law academics in the future.

REFERENCES

- Bloxham, S., and A. West. 2007. Learning to write in higher education: Students' perceptions of an intervention in developing understanding of assessment criteria. *Teaching in Higher Education* 12, no. 1: 77-89
- Boud, D. & Molloy, E., 2012. Rethinking models of feedback for learning: the challenge of design. *Assessment & Evaluation in Higher Education*, (February 2014), pp.1-15.
- Braye, S. M. Preston-Shoot, and R.Johns. 2005. "Law in Social Work Education: Reviewing the Evidence on Teaching, Learning and Assessment." *Social Work Education* 24 (5): 547-563
- Falchikov, N. 2005. Improving assessment through student involvement. Practical solutions for aiding learning in higher and further education. New York, NY: Routledge.
- Gibbs, G. 2014. Dialogue by design: Creating a dialogic feedback cycle using assessment rubrics.
- Knight, P. 2006. The local practices of assessment. *Assessment & Evaluation in Higher Education* 31, no. 4: 435-52.
- Nancy J. White, J.D., 2005. Simple Steps: Teaching Legal Argumentation using the Legal Argument Template. *Journal of Legal Studies in Business*, 15
- Nonaka, I., & Takeuchi, H. (1995). *The knowledge-creating company: how Japanese companies create the dynamics of innovation*. New York: Oxford University Press.
- Niedwiecki, A. (2006). *Lawyers and Learning: A Metacognitive Approach to Legal Education*. *Widener Law Review*, 13(33).
- Owens, A. & Wex, I., 2010. What are the Challenges Involved and the Strategies Employed in Teaching Australian Law to Non-Law Students from Non-English Speaking Backgrounds and Cultures? *Journal of the Australasian Law Teachers Association*
- Reddy, Y. Malini, and Heidi Andrade. 2010. "A review of rubric use in higher education." *Assessment & Evaluation in Higher Education* 35.4 (2010): 435-448.
- Rodrigues, L. L. R., & Pai, R. (2005). Preparation and validation of KM measurement instrument : An empirical study in educational and IT sectors. In S. AlHawamdeh & M. International Conference on Knowledge (Eds.), *Knowledge management : nurturing culture, innovation and technology : proceedings of the 2005 International Conference on Knowledge Management*, North Carolina, USA, 27-28 October 2005 (pp. 582-593). Singapore ; Hackensack, N.J.: World Scientific.
- Sadler, D. R. 1989. Formative assessment and the design of instructional systems. *Instructional Science* 18: 119-44.
- Walker, S., & Hobson, J. 2014. Interventions in teaching first-year law: Feeding forward to improve learning outcomes. *Assessment & Evaluation in Higher Education*, 39(3), 326-338.

Appendix A - IRAC Structure to Problem-Solving

IRAC (Elements)	Duty of Care (DOC)	Breach of DOC	Causation	Remoteness
Issue (Facts)	Was there a duty of care owed by the wrongdoer to the victim?	Did the wrongdoer breach his duty of care?	Did the wrongdoer's act cause harm to the victim?	Was the harm suffered by the victim foreseeable?
Rule (Law)	State the law relevant to DOC. Cite relevant Cases/Act.	State the law relevant to breach of DOC. Cite relevant Cases/Act.	State the law relevant to causation. Cite relevant Cases/Act.	State the law relevant to remoteness. Cite relevant Cases/Act.
Application	Apply the law to the facts. Identify the parties by name & the relevant facts related to the issue	Apply the law to the facts. Identify who the particular wrongdoer is & whether the wrongdoer's conduct amounted to a breach	Apply the law to the facts. Question to address: 'If not for the wrongdoer's actions, would the victim have suffered harm?' If 'YES', wrongdoer is not liable. If 'NO', wrongdoer is liable.	Apply the law to the facts. Consider if the victim's harm is a type that can be expected from the facts.
Conclusion	Establish whether the wrongdoer owed the victim a DOC	Establish whether the wrongdoer was in breach	Establish whether the harm victim suffered was caused by the wrongdoer	Establish whether the harm victim suffered was a foreseeable result of the wrongdoer's action

Comparative Study of Apriori-variant Algorithms

Sofianita Mutalib, Ammar Azri Abdul Subar, Shuzlina Abdul-Rahman, and Azlinah Mohamed

Universiti Teknologi MARA (Shah Alam), Malaysia, {sofi, shuzlina, azlinah}@tmsk.uitm.edu.my

ABSTRACT

Big Data era is currently generating tremendous amount of data in various fields such as finance, social media, transportation and medicine. Handling and processing this “big data” demand powerful data mining methods and analysis tools that can turn data into useful knowledge. One of data mining methods is frequent itemset mining that has been implemented in real world applications, such as identifying buying patterns in grocery and online customers’ behavior. Apriori is a classical algorithm in frequent itemset mining, that able to discover large number of itemset with a certain threshold value. However, the algorithm suffers from scanning time problem while generating candidates of frequent itemsets. This study presents a comparative study between several Apriori-variant algorithms and examines their scanning time. We performed experiments using several sets of different transactional data. The result shows that the improved Apriori algorithm manage to produce itemsets faster than the original Apriori algorithm.

Keywords: Apriori, Association Rule Mining, Frequent Itemset Mining

I INTRODUCTION

Frequent itemset mining is one of the popular techniques in discovering interesting associations among items in database. For example, the resulted associations could be useful information for marketing and determining good prices for products based on customers’ needs. Frequent itemset mining has been used widely in recommendation systems such as in market basket analysis in hypermarket. Recommendation systems are widely used to predict what users are looking for on various kind of things, such as books, movies, music and so on. In recent years, recommendations can be generated from algorithms, such as Apriori. The implementation of recommendation and suggestion systems can be seen in a lot of search tabs, such as in YouTube and Amazon. Recommendation systems can reduce searching time while clicking and scrolling the pages.

Apriori is a multi-pass algorithm; where candidate of itemsets are formed while passing the database by extending prior frequent itemsets with each transaction items. However, lot of candidates of itemset may be infrequent and the process of passing

the database is very time consuming. Apriori applied downward closure property, which refers to an itemset is frequent only if all its subsets are frequent. This means that if {diaper} was found to be infrequent, we can expect {diaper, pizza} to be equally or even more infrequent. So in consolidating the list of popular itemsets, we need not consider {diaper, pizza}, nor any other itemset configuration that contains diaper.

Generally, Apriori uses a "bottom up" approach, where the algorithm starts by finding frequent one itemset and extending one item at a time through candidate generation process. It generates candidate itemsets of length k from item sets of length $k-1$. Then it prunes the candidates which have an infrequent sub pattern. Next, the groups of candidates are tested against the database. It scans the transaction database to determine frequent itemsets among the candidates. The algorithm terminates when no further successful extensions are found. Apriori uses breadth-first search to count candidate item sets efficiently.

In this paper, we prepared an experimental study using Apriori based algorithms in mining itemsets. The rest of the paper is organized as follows. The description of related studies in frequent itemset mining using Apriori based algorithms is given in Section II. Section III describes the experimental setup and Section IV describes the results. Finally, the conclusions are presented in Section V.

II FREQUENT ITEMSET MINING USING APRIORI

The inspirations for association rule mining originally came from market basket analysis. A market basket basically consists of a collection of items purchased by a customer in one transaction. If we investigate the customers’ transactions, we will able to discover group of items that were highly purchased by customers. For example, we found a rule that if customer A buys milk then customer A buys coffee also. So, from this rule, there is a high chance that customer B who buys milk, will also buy coffee. Association rule mining can be generalized to the analysis of sequences, which is called as sequence mining.

The entire dataset, as shown in Table 1, is a sample of transactional data. Association rule mining includes two main processes:

- finding all frequent itemsets with certain support value in the transactional data.

- generating strong association rules from the frequent itemsets that meet confidence threshold.

From both processes, the itemsets and the set of rules will be discovered and can be evaluated as useful knowledge to the domain. Next, we reviewed Apriori algorithm for association rule mining.

Table 1. Sample of Transactional Data, adapted from (Han & Kamber, 2006)

Transaction	Item
1	i_1, i_2, i_5
2	i_2, i_4
3	i_2, i_3
4	i_1, i_2, i_4
5	i_1, i_3
6	i_2, i_3
7	i_1, i_2, i_3, i_4

A. Apriori Algorithm

Apriori algorithm was proposed in 1993 by Agarwal (1994). This algorithm is widely used because it is very simple and easy to be implemented in mining all frequent itemsets in database. The algorithm is basically generating candidate itemsets of a given size, k -itemsets, then scan the database to check, and counts the number of occurrence of each item in the database. Figure 1 shows the pseudo code for Apriori algorithm. The pseudo code for the algorithm is given below for a transaction database T , and a support threshold of $minsup$. C_k is the candidate set for level k .

Algorithm 1 a priori algorithm

```

 $C_1 := \{\{i\} : i \in J\}$  {set of all 1-itemsets},  $k = 1$ 
while  $C_k \neq \emptyset$  do
  For all  $A \in C_k$  determine  $s(A)$  by scanning database.
   $L_k :=$  set of all frequent itemsets in  $C_k$ .
  Construct join  $L_k * L_k$ .
  Prune result by removing sets with infrequent subsets to get  $C_{k+1}$ .
   $k := k + 1$ 
end while
return all frequent itemsets  $\bigcup L_k$ 

```

Figure 1. Apriori Algorithm (Han & Kamber, 2006)

At each step, the algorithm is assumed to generate the candidate sets, A from the large itemsets. The count of $s(A)$, support of itemset A is obtained while scanning T .

- All single itemsets are candidates in the first pass. Any item with support value less than the specific minimum support is eliminated from the pool of candidate itemsets.

- The single itemsets are combined to form two members candidate itemsets. Support values of these candidates are then determined by scanning the database again. Same as before, candidates that has value less than minimum support will be eliminated in becoming frequent two itemsets.
- The next phase, candidates of three itemsets are created. This whole process stops only when all frequent itemsets are found and no further candidate itemset generation is possible.
- All these frequent itemsets are then used to generate association rules and only rules which satisfied the minimum confidence will be stored.

B. Defining Support Measure

Let $I = \{i_1, i_2, \dots, i_m\}$ be a set of m elements called items. A rule is defined as an implication of the form $X \rightarrow Y$, where $X, Y \subseteq I$ and $X \cap Y = \emptyset$. The left-hand side of the rule is named antecedent and the right-hand side is named consequent. Therefore, the association rules can be presented as below and the items are $\{i_2, i_4\}$:

$$i_2 \rightarrow i_4 [s = 40\%, \text{conf} = 60\%]$$

When a specific association satisfies the minimum support threshold, then i is identified as a frequent itemset.

Definition 1 (Support). Let $i \subseteq T$ be a set of items from database, T . The support of an itemset i in T , denoted by $s(i)$, is the proportion of transactions that contain i , Eq. (1):

$$s(i) = \frac{\text{\# of transactions contains } i}{\text{\# of transactions}} \quad (1)$$

If the support of an itemset i is more than minimum support, $minsup$, then i is a frequent itemset.

C. Apriori Algorithm Improved 1

Shirgaonkar *et al.* (2010) has implemented an application using the improved Apriori algorithm for book loan transactional database of a university library. This improvised version of Apriori is solely to increase the efficiency of Apriori in term of time taken for execution. Despite being a simple and easy algorithm, original Apriori algorithm suffers from vast and large generated number of candidates. This has led to highly cost of memory and time taken for each of the execution. The improved Apriori algorithm by Shirgaonkar *et al.* (2010) included a process to remove the transaction that do not have any frequent itemsets prior to mining process. This algorithm safely assumed the transaction/sample that does not have any frequent itemsets would not be considered as a frequent set. This follows the downward property in

Apriori algorithm that if the subset of the item is infrequent, so the superset cannot be frequent. The illustration of the improved algorithm is shown in Figure 2. The improved Apriori algorithm by Shirgaonkar *et al.* (2010) can be summarized as follows:

- All single itemsets are candidates in the first pass. Any item that has support values of less than specified minimum support is eliminated from the pool of candidate itemsets resulting in frequent one item set.
- For every row in transaction database where second item is 0 and first item is infrequent or second item is infrequent and third item is zero, delmark = 0 is marked. (Assume that the end of items in each row is marked with a zero).
- The single itemsets are combined to form two members candidate itemsets. Support values of these candidates are then determined by scanning the database again. Again, only the candidates above the pre-specified minimum support value are retained to get frequent two item set.
- For every row in transaction database where delmark = 1, scan it and determine if third item is 0 and first and second items are infrequent or fourth item is 0 and first and second items are infrequent or fourth item is 0 and second and third items are infrequent then mark delmark = 0.
- The next pass creates 3-member candidate itemsets and the process is repeated. This process stops only when all frequent itemsets are found and no further candidate itemset generation is possible.
- The frequent itemsets constitute the set of frequent items. These frequent item sets are then used to generate association rules which have confidence values greater than or equal to the specified minimum confidence values greater than or equal to the specified minimum confidence. Rules for frequent itemsets are then created.

Due to multiple scanning in the database, the input output equipment becomes heavy. The time taken is normally increasing the efficiency of the Apriori algorithm. However, when the algorithm removes the infrequent items from the original transactional database, the time taken for efficiency may be reduced.

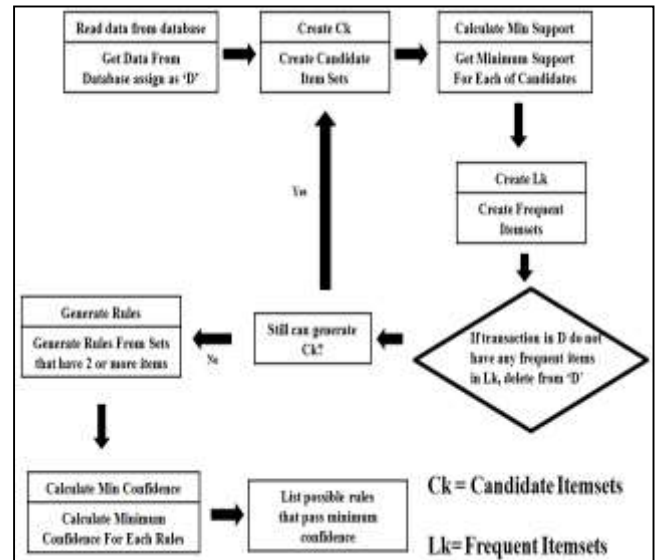

Figure 2. Flow of the Improved Algorithm 1.

D. Apriori Algorithm Improved 2

Another variant of Apriori was proposed by Kaur Gurneet (2014). The algorithm by Gurneet used a simple approach to decrease the time taken and memory used for the execution. This improvise version of Apriori used optimized method by reducing the size of database along with the number of itemsets generated, similarly to Shirgaonkar *et al.* (2010). Furthermore, this algorithm introduced a parameter, *SizeOfTransaction (SOT)*, that stored the number of items for each of the transaction. If the value of *SOT* matches the value of *k*, then the transaction will be deleted. Figure 3 shows the improved algorithm 2 and the pseudocode for this algorithm is shown as below (Gurneet, 2014).

- Firstly, *SOT* column is added to the database.
- In the first iteration, each item is a member of candidate 1-itemset, *C1*. The algorithm simply scans the database to count the occurrences of each item.
- The algorithm will then generate number of items in each transaction as a new parameter, namely; *SizeOfTransaction (SOT)*.
- Depends on the minimum support, for example $min_supp = 2$, the set of frequent 1-itemset, *L1* can be determined.
- After *L1* were generated, the value of *k* becomes 2. Those records of transaction that have $SOT = 1$ in *T* were deleted. These records do not exist in any elements of *C2*.
- After that, the process is repeated until there is no candidate that can be generated.

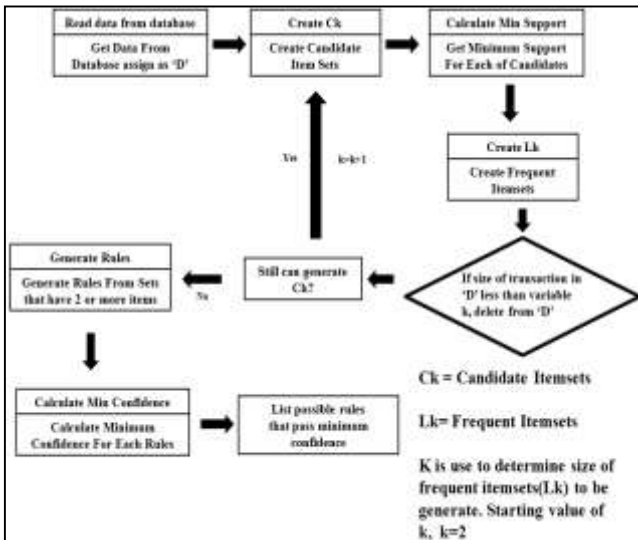

Figure 3. Flow of the Improved Algorithm 2

In order to find the efficient algorithm, we designed a comparative study of time execution in discovering all itemsets that are frequent. This particular method has been applied by various researches that interested in improving the frequent itemset mining algorithm (Bashir *et al.*, 2006, Ahirwal *et al.*, 2012, Yakop *et al.*, 2015).

III EXPERIMENTAL SETUP

In this study, the comparative study was performed to investigate the original Apriori algorithms with two variants of Apriori algorithm, the improved Apriori algorithm by Shirgaonkar *et al.* (2010) as improved Apriori algorithm 1 and improved Apriori algorithm by Kaur Gurneet (2014) as improved Apriori algorithm 2. We were interested to know the outcome of these experiments, due to lack of result findings described in each paper. The experiment was done by varying minimum support value and number of transactions in dataset. The value of minimum support was adjusted and the number of scanning and time of execution were recorded. The numbers of transaction in database were set to 400, 600, 800 and 1000 respectively, and the minimum support are 0.1, 0.3, 0.5, 0.7 and 0.9. Table 2 shows the datasets used and Table 3 summarizes the testing on the algorithms. This experiment was conducted using Windows 8.1 64-bit operating system, Intel(R) Core i5 3.0Hz and 8.00GB RAM.

Table 2. Datasets Used in Experiments

Dataset	# of transactions	# of items
D1	400	1808
D2	600	2357
D3	800	2781
D4	1000	3182

Experiments	Parameter to be recorded
Different numbers of transaction	Time taken for each of the execution depends on scanning time.
Varying number of support value	Time taken for each of the execution depends on the minimum support use.

IV RESULTS

Figure 4-7 show the result of three Apriori based algorithms by using various support values between 0.1 and 0.9.

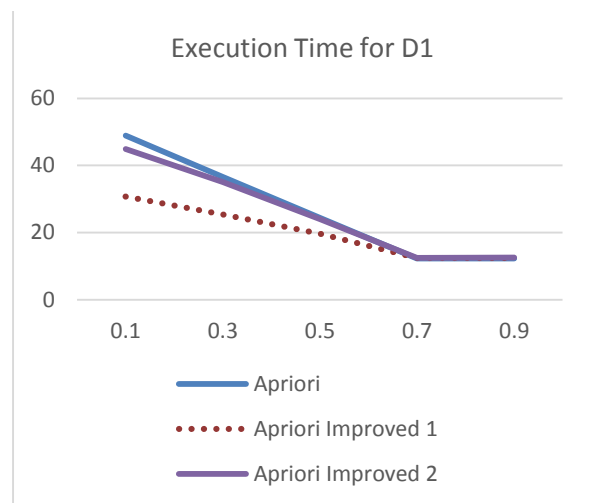

Figure 4. Time Taken for Different Support Value for D1.

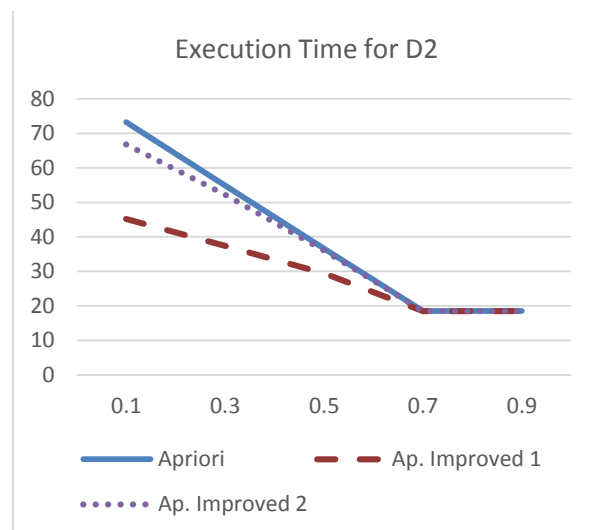

Figure 5. Time Taken for Different Support Value for D2

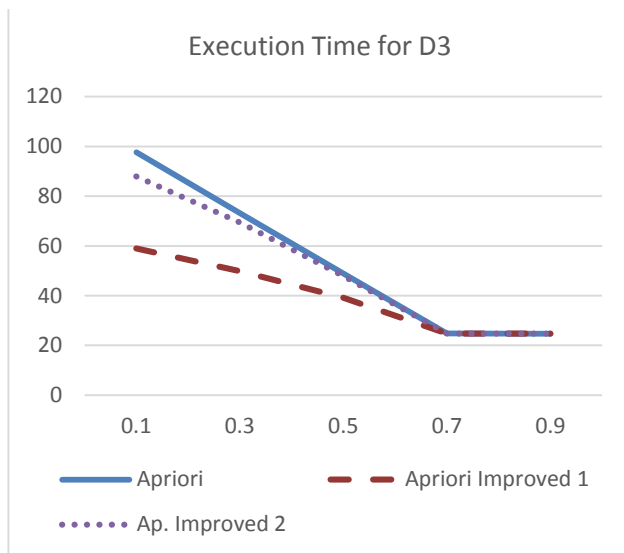

Figure 6. Time Taken Using Different Support Value for D3



Figure 7. Time Taken Using Different Support Value for D4

As can be seen in all these four figures (Figure 4 until 7), there is an obvious difference in time taken for the execution of frequent itemset mining between the original Apriori and the improved Apriori algorithms. Original Apriori algorithm used more time for each of the execution compare to the improved Apriori algorithm. For example, when the experiment was carried out by using 400 transactions and 0.3 minimum support, original Apriori algorithm took 36.62 seconds, while improved Apriori algorithm 1 took 25.43 seconds and improved Apriori algorithm 2 took 35.07 seconds to be executed.

The comparison between Apriori Improved 1 and Apriori Improved 2 has shown that the latter algorithm seems need more time in finding the frequent itemsets. The Apriori Improved 1 algorithm shows a consistent behaviour with different set of transaction numbers. It

shows that the strategy in deleting the item that less than the given support value from the transaction database could help the processing time. Scanning the new processed database without infrequent items does save a lot of time. Meanwhile, Apriori Improved 2 algorithm that uses a parameter that represent the number or items in each transaction, that is *SOT* does contributes the positive merit on processing time. This newly created parameter helps to find transaction that consist adequate item number.

V CONCLUSION

In this paper, the efficiency of the original Apriori algorithm and improved Apriori algorithms with various values of minimum support and number of transaction has been analysed. The results for each of the experiment have been recorded and comparisons have been made. Classical Apriori always need more time, as compared to the Improved Apriori algorithm. The improved algorithm 1 is outperformed algorithm 2 in terms of less processing time and consistently giving good results. Further research using other improved Apriori algorithms on various parameters value can be done. There are several others improved Apriori algorithm (Mohammed & Bassam, 2014; Liao 2009) to be investigated, so that the good strategy can be always applied in proposing a new algorithm.

ACKNOWLEDGMENT

The authors would like to thank to the Ministry of Higher Education, Malaysia for the research grant FRGS 156/2013 and also to Research Management Centre, Universiti Teknologi MARA, Selangor, Malaysia for the support.

REFERENCES

- Agrawal, R., & Srikant, R. (1994). Fast algorithms for mining association rules. In J. B. Bocca, M. Jarke, & C. Zaniolo (Eds.), *Proc. 20th int. conf. very large databases, VLDB* (pp. 487-499). Morgan Kaufman. 12-15.
- Aher, S. B., & Lobo, L. M. R. J. (2013). Combination of machine learning algorithms for recommendation of courses in E-Learning System based on historical data. *Knowledge-Based Systems*, 51, 1-14.
- Ahirwal, R., Kori, N. K, and Jain, Y. K, (2012). Improved Data mining approach to find Frequent Itemset Using Support Count Table. *International Journal of Emerging Trends & Technology in Computer Science (IJETTCS)*, 1(2), 195-201.
- Bashir, S., Shuaib, Sultan, M. Y, Baig, Rauf (2006). Improving Frequent Itemset Mining Algorithms. 2nd International Conference on Emerging Technologies. Pp 257-262.
- Burke, R. (2002). Hybrid Recommender Systems: Survey and Experiments. User Modeling and User-Adapted Interaction. *Journal User Modeling and User-Adapted Interaction*, 12(4), pp. 331-370.
- Borges, L. C., Marques, V. M., & Bernardino, J. (2013). Comparison of data mining techniques and tools for data classification. *Proceedings of the International C* Conference on Computer Science and Software Engineering*, 113-116. Doi:10.1145/2494444.2494451
- Chen, Chia-Chen, & Chen, An-Pin. (2007). Using data mining technology to provide a recommendation service in the digital library. *The Electronic Library*, 25(6), 711-724. doi: 10.1108/02640470710837137

- Chesnevar, C., Maguitman, A., & González, M. (2009). Empowering Recommendation Technologies Through Argumentation. In G. Simari & I. Rahwan (Eds.), *Argumentation in Artificial Intelligence* (pp. 403-422)
- Chhavi Rana, S. K. J. (2012). Building a Book Recommender system using time based content filtering. *WSEAS Transactions On Computers*, Issue 2, Volume 11, February 2012, pp 27-33.
- De Pessemier, T., Dooms, S., & Martens, L. (2013). Comparison of group recommendation algorithms. *Multimedia Tools and Applications*, 72(3), 2497-2541.
- Kaur, G. (2014). Improving The Efficiency of Apriori Algorithm In Data Mining. *International Journal of Science, Engineering And Technology*, Volume 02 Issue 05 June- 2014, pp 315-326.
- Han, J. and Kamber, M. (2006). *Data Mining: Concepts and Techniques*. 2nd Edition, Morgan Kaufmann Publishers.
- LakshmiPriya, G., & Hariharan, Shanmugasundaram. (2012). An efficient approach for generating frequent patterns without candidate generation. Paper presented at the Proceedings of the International Conference on Advances in Computing, Communications and Informatics, Chennai, India.
- Liao, B. (2009). An Improved Algorithm of Apriori. In Z. Cai, Z. Li, Z. Kang & Y. Liu (Eds.), *Computational Intelligence and Intelligent Systems* (Vol. 51, pp. 427-432)
- Mohammed Al-Maolegi, B. A. (2014). An Improved Apriori Algorithm for Association Rules. *Natural Language Computing. International Journal on Natural Language Computing (IJNLC)* Vol. 3, No.1, February 2014, pp. 21-29
- Mohammad-Arsyad, M.Y, Sofianita, M., Shuzlina Abdul-Rahman, Azlinah, M. (2015). Data Projection Effects in Frequent Itemsets Mining. *Soft Computing in Data Science*, Volume 545 of the series Communications in Computer and Information Science, 23-32.
- Mettouris, C., & Papadopoulos, G. A. (2013). Ubiquitous recommender systems. *Computing*, 96(3), pp. 223-257.
- Pazzani, M., & Billsus, D. (2007). *Content-Based Recommendation Systems*. In P. Brusilovsky, A. Kobsa & W. Nejdl (Eds.)
- Rajola, F. (2013). Data Mining Techniques Customer Relationship Management in the Financial Industry (pp. 109-125)
- Resnick, P. and Varian, H.R. Recommender Systems. *Communications of the ACM*, Vol. 40, No. 3, 1997, pp. 56–58
- Shirgaonkar, S., Rajkumar, T., & Singh, V. (2010). Application of improved Apriori in University Library. *Proceedings of the International Conference and Workshop on Emerging Trends in Technology*, Mumbai, Maharashtra, India. Pp 535-540, do:>10.1145/1741906.1742027
- Xujing, B., & Weixiang, X. (2013). The Research of Improved Apriori Algorithm. In Z. Zhang, R. Zhang & J. Zhang (Eds.), *LISS 2012* (pp. 1007-1012): Springer Berlin Heidelberg.

Benchmarking Process of Knowledge Management Best Practice Model for Higher Learning Institution

Halijah Ismail, Rusli Abdullah, and Yusmadi Yah Jusoh

Universiti Putra Malaysia (UPM), Malaysia, halijahismail78@gmail.com; rusli.yusmadi@fsktm.upm.edu.my

ABSTRACT

This paper aims to propose the benchmarking process for KM Best Practice Model to suits Higher Learning Institution (HLI) environment. The need for Benchmarking of KM Best Practice Model is due to the lack of research made to confirm the Best KM Model for HLI. Benchmarking process will helps HLI to ensure continuous improvement and hopefully will uplift KM state in HLI by implementing benchmarked KM Best Practice Model due to the stagnant state of KM in HLI for the past 10 years. *Method:* Literature for Benchmarking were extracted to propose the right benchmarking process for HLI environment. Several KM models were extracted from the literature and reviewed. The KM Model were selected to suit the HLI environment in Malaysia, this is to ensure the KM Model selected served as the best KM model to be practice in the future or practically named internal benchmarking. *Conclusion:* The paper proposed Benchmarking process for KM Best Practice Model to suits HLI. The moderator for KM Best Practice Model were identified to proceed with the KM Best Practice Components effectiveness validation in the future study. This study also proposed a conceptual Model for KM Best Practice.

Keywords: Knowledge Management, Knowledge Management Best Practice, Higher Learning Institutions.

I INTRODUCTION

Rahman (2016) recorded the low state of knowledge sharing behavior in HLI Malaysia, to support the research made previously by (Tasmin, 2012). To ensure the continuous improvement for KM in HLI, the need for KM Best Practice Benchmarking is a must in order to identify the KM Best Practice Components that proved to works effectively in KM process within the organization. This paper aims to propose the benchmarking process for KM Best Practice model to suits the HLI environment. However, most organization objectives of benchmarking is to achieve continuous improvement for development recorded at 68% while the remaining 32% as regulatory purpose said (Magutu et al., 2011). The literature for

benchmarking mostly support the benchmarking process for business domain, however the process might be suitable to be implement in HLI. This is what will be discuss in this paper.

II BENCHMARKING PROCESS OF KM BEST PRACTICE MODEL

KM process known as an innovative approach for performing certain task or function in the best possible way also both internally and externally (Lu et al., 2010) This process naturally drives collaboration of teamwork and brings consistency to some extent. Though the k-worker equipped with the ability to think and execute responsible for knowledge creation in the organization. Their value are measured by the terms of attitude, learning, ability, innovation, excellence, speed and quality. This process transform the information and intellectual assets into a value that connects people (L S, et.al, 2010) which enhance the learning process (Che Rusuli, et.al, 2012). The k-worker works based on k-process on a systematic approach to enable KM also known as technology and it must be well defined to ensure its functions to suits the organizational needs and requirements (Abdullah R, et. al, 2008) and they must also fits for measurement (Yusoff, et al, 2012) & (Okyere-kwakye, et al, 2012). The KM system must therefore be process-driven and easy to embrace. Maximizing the scalability and consistency will help k-worker embrace KM practice naturally which must be align with the organizational function and objectives. As result, KM Best practice effectiveness can be measured and validate by answering the question what is known, what is need to be known, why it is need to be known and how this known make the organization gain from the knowledge and value the known. This measurement of KM effectiveness can be explain thru the validating process of KM Best Practice model prototype development (Renato & Junior, 2008). However the first step towards the process might be benchmarking. Butnariu & Milosan (2012) added, best practice helps HLI to determine the KM growth which is the first steps towards the benchmarking process of an organization.

Benchmarking works as an ongoing management tools recognized for identifying and enhancing organizational capability which investigate and learning experience that ensure the coverage of best practice are analyzed, adopted and implemented said (Lu et al., 2010) this process are done by a systematic comparing of the best product process said (Scott, 2011) agreed by (Hoist et al., 1995) benchmarking also commonly called 'best practice' said (Elmuti & Kathawala, 1997). He also list the types of benchmarking into; internal, competitive, functional and generic. In this study the focus might be on the generic benchmarking due to the nature of defining the best practice for KM Process. (Lee & Lee, 2007) confirmed the relationship between KM capabilities, KM process and KM performance as related to each other however focus must be in two dimension which is the organizational knowledge process and the organizational capabilities, to ensure the benchmarking procedure is on the right direction.

Benchmarking are obviously to validate the KM Best Practice Model as the best Model. This KM Best Practice Model then can be used as a guideline or benchmarked model for HLI. The benchmarking of KM Model will help HLI to leverage KM and to discover the potential area for improvement, providing an incentive to change, and insist in setting targets and formulating plans and strategies (Scott, 2011), this is due to the nature of KM process as the factors for knowledge assets maximization (Marr, 2003), he also added the need for consideration of the culture issues in benchmarking the KM Process due to the dynamic knowledge creation process. He also added the reminder for benchmarking issue regarding the theories of benchmarking which computer science domain on cognitivist and auto-poetics, while technology science would prefer the connectionist, this scenario will not help the benchmarking process between the two domains. However this research will focus on the connectionist by connecting human and technology not only being cognitivist which identify and collect and disseminating the explicit knowledge and auto-poetically transfer the knowledge internally.

III RESULTS

This paper reviewed several literature of benchmarking process (Okoli & Schabram, 2010) and summarized the proposed Benchmarking Process of KM Best Practice Model (Goldman et al, 2014). Selected KM models are summarized from the previous study will be used as reference model

(Tasmin & Woods, 2008b). A proposed Benchmarking Process for KM Best Practice Model to suits the HLI are being concluded later (Hoist et al., 1995).



Figure 1. Benchmarking Process for KM Best Practice Model.

Based from the first phase of the Benchmarking process, the study cluster the KM Best Practice Components into 1] Organizational Culture, 2] Organizational Structure, 3] Human Psychology, 4] Infrastructure, 5]Technology, 6] Knowledge Process and 7] Knowledge Audit. These components are identified as the component to be benchmark.

A. Organizational Culture

Knowledge culture in the organizations defined as the combination of common expectations, tacit rules, shared experience and social norms that later shape the attitude and behaviour of the members in the organization to support and encourage the knowledge sharing activities through the interaction and relationship building to overcome CKM barriers said (Tasmin & Woods, 2008b) &(Tasmin & Woods, 2007). While (Ramachandran & Chong, 2009) suggested the culture in the organization must include; clan culture, adhocracy culture, hierarchy culture and market culture . The leadership was most agreeable components as KM Best Practice components by previous researcher, followed by motivation. Experience was recognize as the moderator (K. J. Lee & Jeon, 2004) while mutual trust were proved to be effective by (Aulawi & Govindaraju, 2008; Guan, et al., 2006; Okyere-kwakye, et al., 2012; Panahi, et al., 2012; Ratnasingam, 2008; Tasmin & Woods, 2008b). Truth and learning followed to be effective KM Components as agreed by (Chayanukro, et al., 2012; Davernport, et al., 2000; Nasir, 2010; Wai, et al., 2012). The moderate effective KM Components for organizational culture are; collaboration, believe, strategy and mutual-reciprocity. The newly introduced KM Components are, altruism, enjoyment, self-efficiency and complexity by (Okyere-kwakye, et al., 2012) and kiasu-ism (Guan et al., 2006) while the other culture components includes psychology, incentives, rewards, and awareness.

B. Organizational Structure

Organizational Structure defines how the activities in the organization will help towards the achievement of organizational aim. A robust and well defined organizational hierarchy is the essential to all organization said (Mohsennasab et al., 2008). The organizational structure must contain organizational strategy said (Aulawi & Govindaraju, 2008) and agreed by (Raja Kasim, 2008). The organization must also be headed by smart leader said (Adli & Hassan, 2003; Guan, et al., 2006; Jahani, et al., 2010; Salleh, 2012; Tasmin & Woods, 2007).

C. Human Psychology

The psychology of human related to emotional intelligence which powering the tacit knowledge sharing through team affiliation in the organization said Othman & Abdullah (2008) if added with positive attitude knowledge sharing among the member in the organization can be a success claimed Ainiarifah & Norizan (2008). The KM Best Practice components might includes; Motivation, Incentive (Ta, et al., 2012), Rewards (Abdullah, et al., 2008b; Adli & Hassan, 2003; Guan et al., 2006) and Awareness. Literature supported rewards as the favorite proposed components followed by awareness. While motivation and Incentive were not literally supported well as reviewed in the study. However this might not be the indicator for non-effective KM Best Practice components before validating it.

D. Infrastructure

Aulawi & Govindaraju (2008) referred infrastructure as the apparatus of the organization aims to facilitate the creation of an environment which enables members of the organization to share their knowledge with one another intensively, infrastructure linked to the technology, structure and organizational culture claimed (Adli & Hassan, 2003).

E. Technology

Internet Technology (IT) become a link that connects people via KMS (Manuri & Raja, 2011; Mohamad,et., 2008), then the era of mobile technology took over the KMS which allow cloud technology (Alzaza & Yaakub, 2012), however, an appropriate technology matches to KM process will make knowledge being able to flow among the member of the organization must ensure the user update themselves with the latest technology (Zakaria, 2008). Care must be on the KM application such as data ware housing, data mining, business intelligence management information system, decision support system, customer

relationship management and also competitive intelligence. The latest technology might be consider is the cloud (Abdullah, et al., 2011).

F. Knowledge Process

The main KM Process focus on three main activities namely knowledge creation, knowledge storage and knowledge distribution which gives impact on the knowledge performance said (Zaim, 2006). This study expend the knowledge process activities to eight activates to complete the cycle of knowledge process. The KM process includes the activity of knowledge creation in the organization, the activity started from the knowledge generation said (Che Rusuli et al., 2012), followed by knowledge acquisition added (Abdullah et al., 2008b; Zakaria, 2008), knowledge capture was clearly defined in the study by (Che Rusuli et al., 2012). Knowledge storage play an important activity in knowledge process where the storage of the knowledge are crucial due two form of the knowledge itself which is explicit and tacit knowledge that mingled among the organizational members. The used and sharing of knowledge must be provided with correct platform to ensure the effectiveness of the knowledge being shared and used (Dhillon, et al., 2010; L S et al., 2010). The knowledge process activities that always been abandon by most organization is knowledge preserved, the issue of knowledge preserve where preferable mostly at the library but being neglected in the HLI (Ayobami & Rabi, 2012; Che Rusuli et al., 2012).

G. Knowledge Audit

The knowledge audit refer to the measurement of the effectiveness of KMS, the measurement might involved the tools for measuring KM readiness of the organization suggested (Renato & Junior, 2008; Tasmin & Woods, 2007) to ensure KM are competent enough to be implemented (Zakaria, 2008). While knowledge audit is to ensure the organization maintain its performance via productivity and quality assurance.

1	2	3	4	5	6	7
Organizational culture	Organizational structure	Human Psychology	Infrastructure	Technology	Knowledge Process	Audit
a. Education	a. Strategy	a. Motivation	a. Architecture	a. Decision	a. Creation	a. Measurement
b. Trait	b. Leadership	b. Structure	b. Application	b. Decision	b. Acquisition	b. Audit
c. Learning	c. Organizational Structure	c. Research	c. Organization	c. Integration	c. Capture	c. Feedback & Rewards
d. Collaboration	d. Strategy	d. Awareness	d. Practicality	d. Integration	d. Storage	
e. Social Trust			e. Interact Mode	e. Dissemination		
f. Behavior				f. Evaluation		
g. Value				g. Review		
h. Experience				h. Preserve		
i. Ability						
j. Moral						
k. Equipment						
l. Motivation						
m. Competence						
n. Judgment						
o. Experience						

Figure 2. KM Best Practice Components Summary



Figure 3. Knowledge Process Components Benchmarking Result

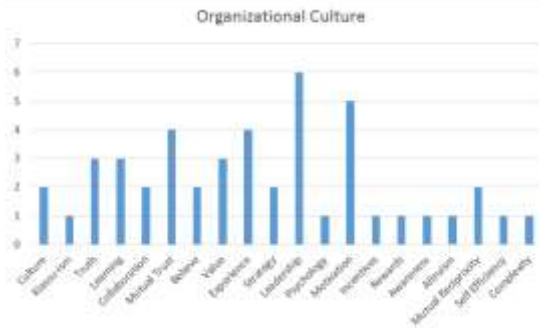

Figure 4. Organizational Components Benchmarking Result

IV DISCUSSION

Literature on KM Best Practice model has put forwards few models to be set as benchmarking model in this study. This KM Model widely known and applied for the past 10 year's duration. Namely ; 1: The Sand Cone Model, 2: Socio-technical Model , 3: KM at HLI Model, 4: Knowledge Model for Universities Implementation. It is to be acknowledged that few KM Model are also included in this study due to prospect of effectiveness.

A. The Sand Cone Model

(Che Rusuli et al., 2012) proposed a new KM process namely K- Records and K-Preserved. This process has been left with little attention, however it is a positive influence to provide appropriate KM practice in the HLI environment.

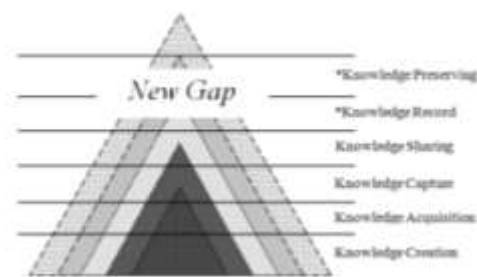

Fig. 5: The Sand Cone Model

Knowledge Creation - (Che Rusuli et al., 2012) reported that HLI have excelled at creating scholarly information and intelligence from data, but they have tended not to create knowledge from

intelligence in addition HLI have done little to use organizational information to create knowledge that can be used to improve the functionality of HLI process not only becoming the collection in the house but must be able to produce the right amount of information at the right time.

Knowledge Acquisition - (Che Rusuli et al., 2012) documented that HLI have a restricted limited funding, technology, staff and space towards presenting the corporate acquisition in order to provide continuous education and staff training to all staff members. The organization must identify the relevant and none relevant or essential knowledge to the organization (Abdullah et al., 2008b) and (Che Rusuli et al., 2012) added that HLI can make use of the producer of the literature published and perhaps externally (Abdullah et al., 2008b) defined knowledge codification or coordination as the steps required to place the organizational knowledge into a form that makes it accessible to others who may need it.

Knowledge Capture - (Che Rusuli et al., 2012) stated that HLI could play a major part in the knowledge capture processes, whereby the staff have the capabilities to organize and manage the knowledge which is to become the knowledge central to initiate knowledge capture and storage from lost. However many HLI settings, have not yet develop a systematic approach to organize the knowledge of the enterprise and making it available to other HLI and the staff in order to improve the operational of the organization. Therefore, the need to understand the customer and their requirements and the ability to provide appropriate and timely services are a must have component to avoid unattended knowledge this will lead to the waste of knowledge.

Knowledge Sharing - According to (Tasmin & Woods, 2007), a structured approach to knowledge dissemination through their theory of a knowledge spiral four modes knowledge conversation namely; socialization, externalization, combination and internalization. Despite that Malaysian HLI are still not yet being hormonally adapted with the knowledge sharing culture that might create the barrier to knowledge sharing in the organization may be due to fear of losing the exclusiveness of the knowledge (Guan Gan et al., 2006). The need to create knowledge sharing culture in the organization is a must in order to make sure the new skills and knowledge in the organization to remain relevant yet the establishment of the means for knowledge sharing must not be neglected.

Knowledge Record - (Saufi et al., 2012) suggest the importance of being able to develop and design the knowledge of how to records due to the lack of recording ability among the staff of an organization in order to create the environment of continuous learning that so far hasn't being achieved by HLI.

Knowledge Preserving - (Che Rusuli et al., 2012) suggested that knowledge preservation for the key material of the organization is a must for future used of the valuable knowledge in the organization. These all will lead to the contribution of the organization to invest in hardware purchasing and software to preserve the recorded and codified knowledge in the organization so that it can be used in the future and not become obsolete. This process should be considered as organizational innovation and evolving process in HLI. (Rusuli, 2012) also added with the indication by Ismail (2006) that HLI preservation programs take into consideration factors such as the physical environment in which information resources are housed; disaster control; conservation; reformatting; routine maintenance; security and reader education and all this responsibility goes to the professional and top management.

B. Socio-technical Model

(Tasmin & Woods, 2008a) proposed 5 major domain of KM namely knowledge leadership, knowledge culture, knowledge technology, knowledge process, and knowledge measurement (Che Rusuli et al., 2012) as the components for the Socio-technical model.

Knowledge culture in the organizations that combined the common expectations, tacit rules, shared experience and social norms that later shape the attitude and behaviour of the member in the organization support and encourage the knowledge-sharing activities through the interaction and relationship building to overcome CKM barriers (Tasmin & Woods, 2007). He said that managing knowledge are based on sharing culture that fully depend on trust and good relationships among people within an organization. While (Guan Gan et al., 2006) added that mutual trust only exist in an organization when its members believe in the integrity, character and ability of each other

KM infra-structure acted as a basic foundation for other knowledge enabling components to work as a whole. The networked computers in the organization helps people in the organization shares

ideas, information, and knowledge that speed up the communication and reduce cost of knowledge sharing (Tasmin & Woods, 2008a).

Technology in the organization means the used of IT-Based KM System. (Tasmin & Woods, 2007) grouped the CKM technology channel into four types namely; database, decision support systems, groupware- includes e-mail and video conferencing and intranet webs.

(Tasmin & Woods, 2007) claimed that measurement is the critical aspect of any knowledge management effort to strike the right balance between organizational and technological changes in the organization. This was performed by tools for measuring knowledge readiness in the organization. The issue in measurement comes from the fearful of measuring the knowledge outcomes or the return-on-investment of their efforts, the obstacle to measure the knowledge delivery effectiveness by having the right system of measurement.

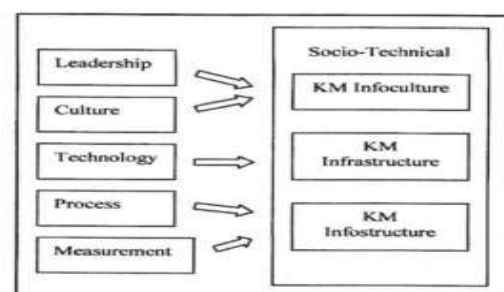

Figure 6. The Socio-Technical Model

C. KM at HLI Model

(Abdullah et al., 2005) recorder that KM Tools consist of knowledge use, knowledge finding, knowledge creation and knowledge packaging, normally called KM technologies such as mailing, search and retrieval system that are used to accomplish certain mission and objectives in the organization.

The additional of audit component was suggested in order to maintain and to ensure performance of the KMS according to its specification. It is also can be used as a benchmark of the KMS to maintain its quality and productivity as well as to increase its ROI. While the soft aspect explain the soft issues on the component namely; motivation, Incentives, Rewards and Awareness, that play the role to support the development and the implementation of KMS in the organization. This is totally involved the human factors.

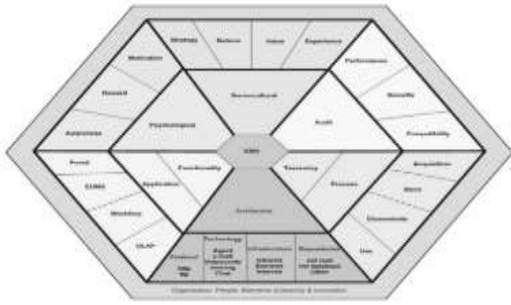

Figure 7. The KM at HLI Model

D. Knowledge Model for Universities Implementation

The model summarized that info-structure support; infrastructure capacity; info-culture; and knowledge acquisition, generation, storage and dissemination; are important factors in shaping the KM initiatives. Info- structure is found to be the most significant variable. This is consistent with other studies, which confirm that people and cultural issues are the most difficult problems to resolve, but tend to produce the greatest benefits (Mohayidin, et al., 2007).

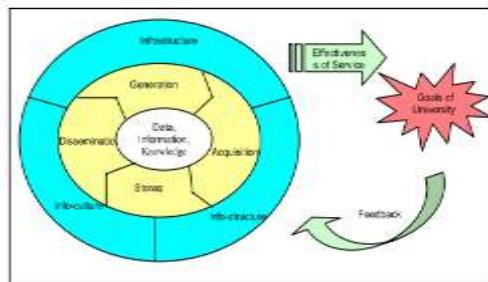

Figure 8. Knowledge Model for Universities Implementation

V CONCLUSION

The study limits to the Malaysia HLI environment literature. The literature provided in the paper might also include km innovation and business due to profit orientation environment created lately in HLI. Distinguish environment for Asian culture are being considered due the focus on local environment (Niedderer & Imani, 2009).

The need for measurement of KM model in the HLI are essential because the measurement of knowledge contribution in organizational marks the correct execution of every activity, its frequent evaluation, the monitoring of any variations occurred throughout its development and finally the accomplishment of eventual corrective actions that intends the correction of routes and agility in

attainment of its goals claimed (Renato & Junior, 2008). However, external benchmarking may not always be the best way to solve problems and maintain competitive advantage said (Lu et al., 2010).

The study concluded, experience, awareness & knowledge need seems to be the moderator for KM Best Practice despite of components required for KM Best Practice implementation, the key activities that measure KM in the organization to be validate the effectiveness are the Knowledge Process. This process are being supported by the Organizational Culture, well organized Organizational Structure, properly deal Human Psychology, supported by strong and robust Infrastructure and well equipped with Technology and lastly maintain the quality by Knowledge Audit. The KM Best Practice Components will proof to be effective if only it is validate as answering the knowledge of Know-Who, Know-How, and Know-Why. This will continue in the future study.

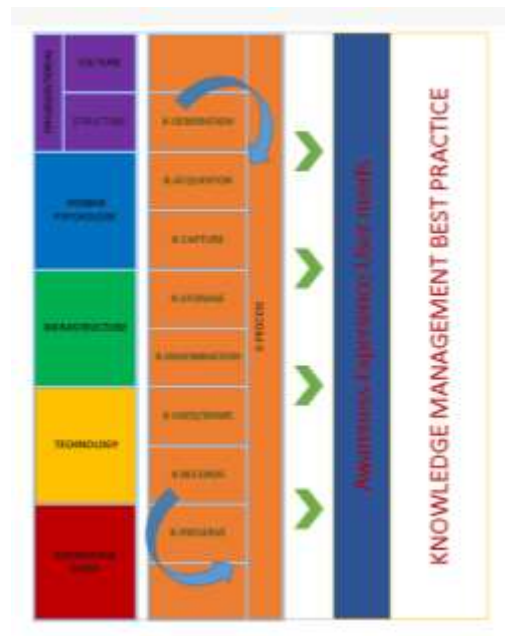

Figure 11 : KM Best Practice Model for HLI

ACKNOWLEDGMENT

The authors would like to acknowledge her PhD supervisor for guiding this paper.

REFERENCES

Abdullah, R., Eri, Z. D., & Talib, A. M. (2011). A Model of Knowledge Management System for Facilitating Knowledge as a Service (KaaS) in Cloud Computing Environment. In Research and Innovation in Information Systems (ICRIIS), 2011 International Conference.

- Abdullah, R., Selamat, M. H., Jaafar, A., Abdullah, S., & Sura, S. (2008a). An Empirical Study of Knowledge Management System Implementation in Public Higher Learning Institution, 8(1).
- Abdullah, R., Selamat, M. H., Jaafar, A., Abdullah, S., & Sura, S. (2008b). An Empirical Study of Knowledge Management System Implementation in Public Higher Learning Institution. *IJCSNS International Journal of Computer Science and Network Security*, 8(1), 281–290.
- Abdullah, R., Selamat, M. H., Sahibudin, S., & Alinda, R. (2005). A Framework For Knowledge Management System Implementation In Collaborative Environment For Higher Learning Institution. *Journal of Knowledge Management Practice*, 6(March). Retrieved from <http://www.tlinc.com/artic183.htm>
- Adli, R., & Hassan, S. (2003). Knowledge Management Systems for Decision Makers in Public Universities Malaysia, 339–348.
- Ainiarifah, A. B., & Norizan, M. Y. (2008). Using Teaching Courseware to Enhance Classroom Interaction as a Method of Knowledge Sharing. *Journal of Information System, Research & Practices*, 1(1). Retrieved from <http://ejum.fsktm.um.edu.my/ArticleInformation.aspx?ArticleID=652>
- Alzaza, N. S., & Yaakub, A. R. (2012). Proposed Research Model for Students' Acceptance of M-learning Services among Malaysian Higher Education. In *Knowledge Management International Conference (KMICe) 2012* (pp. 4–6).
- Aulawi, H., & Govindaraju, R. (2008). Identifying the Relationship Between Knowledge Infrastructure, Knowledge Sharing and Innovation Capability: System Dynamics Approach. In *Knowledge Management International Conference 2008* (pp. 310–316).
- Ayobami, A., & Rabi, S. (2012). Knowledge Discovery in Database: A Knowledge Management Strategic Approach. In *Knowledge Management International Conference (KMICe) 2012* (pp. 4–6).
- Chayanukro, S., Mahmuddin, M., & Husni, H. (2012). Behavior Usage Model to Manage the Best Practice of e-Learning. In *Knowledge Management International Conference 2012* (pp. 4–6).
- Che Rusuli, M. S., Tasmin, R., & Takala, J. (2012). Knowledge Record And Knowledge Preservation: A Conceptual Framework Of Knowledge Management Practice At Malaysian University Libraries. *International Journal of Information Technology and Business Management*, 3(1), 30–37.
- Che Rusuli, M., Tasmin, R., Takala, J., & Hashim, N. (2012). Knowledge Management Process At Malaysian University Libraries: A Review. *The International Journal of Social Science*, N0.1, 1–16. Retrieved from <http://www.tijoss.com/1stVolume/Muhammad Rasuli.pdf>
- Davenport, T.H, and Prusak, L. (2000). *Working Knowledge- How Organizations Manage What They Know*. Cambridge: Harvard Business School Press.
- Dhillon, S. K., Rahman, A. A., & Abidin, W. Z. (2010). Evaluation of Senior ICT Requirement based on Knowledge Sharing Framework. *Knowledge Management International Conference (KMICe) 2010*, 446–452. Retrieved from http://www.researchgate.net/publication/257410429_Evaluation_of_Senior ICT Requirement_based_on_Knowledge_Sharing_Framework
- Elmuti, D., & Kathawala, Y. (1997). An overview of benchmarking process: a tool for continuous improvement and competitive advantage. *Benchmarking: An International Journal*, 4(4), 229–243. <http://doi.org/10.1108/14635779710195087>
- Goldman, a., Eggen, B., Golding, B., & Murray, V. (2014). The health impacts of windstorms: A systematic literature review. *Public Health*, 128(1), 3–28. <http://doi.org/10.1016/j.puhe.2013.09.022>
- Guan Gan, G. G., Ryan, C., & Gururajan, R. (2006). *Kajian Malaysia*, Vol. XXIV, No. 1 & 2, 2006. *Kajian Malaysia*, XXIV(1), 97–128.
- Halijah Ismail, & Abdullah, R. (2015). Knowledge Management Best Practice Model In Higher Learning Institution: A Systematic Literature Review. In *ICRIIS 2015*.
- Jahani, S., Ramayah, T., & Abdullah Effendi, A. (2010). Reward System and Leadership Role as Key Factors Influencing Knowledge Sharing Behavior among Academicians in Iran: An Empirical Study. In *Knowledge Management International Conference (KMICe) 2010* (pp. 473–478).
- L S, Y., Tasmin, R., Che Rusuli, M. S., & Hashim, N. (2010). Factors Influencing Knowledge Management Practices among Multimedia Super Corridor (MSC) organizations. *Communications of the IBIMA*, 2010, 1–12. <http://doi.org/10.5171/2010.834296>
- Lee, K. J., & Jeon, B. (2004). Analysis of Best Practice Policy and Benchmarking Behaviour for Government Knowledge Management. In *IFIP International Federation for Information Processing 2004* (pp. 70–79). http://doi.org/10.1007/978-3-540-24683-1_8
- Lee, Y.-C., & Lee, S.-K. (2007). Capabilities, Processes, and Performance of Knowledge Management: A Structural Approach. *Human Factors and Ergonomics in Manufacturing*, 17(1), 21–41. <http://doi.org/10.1002/hfm>
- Lu, I.-Y., Mao, C.-J., & Wang, C.-H. (2010). Intrafirm technology and knowledge transfer: a best practice perspective. *International Journal of Technology Management*, 49(4), 338–356. <http://doi.org/10.1504/IJTM.2010.030162>
- Magutu, P. O., Mbeche, I. M., Nyamwange, S. O., & Nyaoga, R. B. (2011). A Survey of Benchmarking Practices in Higher Education in Kenya: The Case of Public Universities. *IBIMA Business Review*, 2011, 1–20. <http://doi.org/10.5171/2011.357694>
- Manuri, I., & Raja Yaacob, R. A. (2011). Perceptions of knowledge creation, knowledge management processes, technology and applications in military organisations. *Malaysian Journal of Library & Information Science*, 16(1), 73–85.
- Marr, B. (2003). Consider the culture when benchmarking KM Process. *Measurement Snapshot*, 6(5), 6–7.
- Mohamad, A. K., Sahib, S., & Mohd Yusof, M. (2008). Enabling Collaborative Organizational Learning (OL) Through Email System: The Socio-Technical Approach – A Case Study. In *Knowledge Management International Conference (KMICe) 2008* (pp. 81–86). Retrieved from <http://www.kmice.cms.net.my/ProcKMICe/KMICe2008/Pdf/81-86-CR63.pdf>
- Mohan, K., Hoist, R., Daly, D., & McMohan, W. (1995). Statements on Management Accounting Effective Benchmarking Statements on Management Accounting.
- Mohayidin, M. G., Azirawani, N., Kamaruddin, M. N., & Idawati, M. (2007). The Application of Knowledge Management in Enhancing the Performance of Malaysian Universities. *The Electronic Journal of Knowledge Management*, 5(3), 301–312.
- Mohsennasab, M. H., Nezhad, G. A., & Abtahi, S. H. (2008). Knowledge Management In Government Organizations. In *Knowledge Management International Conference (KMICe) 2008* (pp. 543–545). Retrieved from <http://www.kmice.cms.net.my/ProcKMICe/KMICe2008/Pdf/543-545-CR73.pdf>
- Nasir, N. R. (2010). Knowledge Sharing Practice: Comparison of Offline and Online Communities. In *Knowledge Management International Conference (KMICe) 2010* (pp. 409–412). Retrieved from http://www.kmice.cms.net.my/ProcKMICe/KMICe2010/Paper/Pg409_412.pdf
- Niedderer, K., & Imani, Y. (2009). Developing a Framework for Managing Tacit Knowledge in Research using Knowledge Management Models Developing a Framework for Managing Tacit Knowledge in Research using Knowledge Management Models Problems with Knowledge in Research. In *Proceedings of DRS2008, Design Research Society Biennial Conference* (pp. 027/1–027/24). Retrieved from <http://shura.shu.ac.uk/507/>
- Okoli, C., & Schabram, K. (2010). Working Papers on Information Systems A Guide to Conducting a Systematic Literature Review of Information Systems Research. *Working Papers on Information Systems*, 10(26), 1–51. <http://doi.org/10.2139/ssrn.1954824>
- Okyere-kwakye, E., Md Nor, K., Ziaei, S., & Tat, H. H. (2012). Effect of Individual Factors on Knowledge Sharing. In *Knowledge Management International Conference (KMICe) 2012*.
- Okyere-kwakye, E., Nor, K., & Ologbo, A. (2012). Factors That Impel Individuals' To Share Knowledge. In *Knowledge Management International Conference (KMICe) 2012* (pp. 4–6). Retrieved from <http://www.kmice.cms.net.my/ProcKMICe/KMICe2012/PDF/CR82.pdf>

- Othman, A. K., & Abdullah, H. S. (2008). The Influence of Emotional Intelligence on Tacit Knowledge Sharing in Service Organizations. In Knowledge Management International Conference (KMICe) 2008 (pp. 146–152).
- Panahi, S., Watson, J., & Partridge, H. (2012). Social Media and Tacit Knowledge Sharing: Developing a Conceptual Model. World Academy of Science, Engineering and Technology, 64, 1095–1102.
- Rahman, M. S., Osmangani, A. M., & Daud, N. M. (2016). Knowledge sharing behaviors among non academic staff of higher learning institutions Attitude, subjective norms and behavioral intention embedded model. Library Review, 65(1/2), 65–83. <http://doi.org/10.1108/09574090910954864>
- Raja Kasim, R. S. (2008). The Commercialization of Knowledge Management Practices to K-based Development in Malaysia. In Knowledge Management International Conference (KMICe) 2008 (pp. 1–8). Retrieved from <http://www.kmice.cms.net.my/ProcKMICe/KMICe2008/Pdf/1-8-CR22.pdf>
- Ramachandran, S. D., & Chong, S. C. (2009). Competing Values Framework and Knowledge Management Processes in Malaysian Universities. In Knowledge Management International Conference 2009 (KMICe2009) (pp. 110–115).
- Ratnasingam, M. (2008). The Contribution of Teamworking, Thinking Styles and Innovation to Knowledge Management. In Knowledge Management International Conference 2008 (KMICe2008) (pp. 386–390).
- Renato, J., & Junior, S. (2008). Knowledge Management Contribution Measurement Model. In Knowledge Management International Conference (KMICe) 2008 (pp. 500–504). Retrieved from <http://www.kmice.cms.net.my/ProcKMICe/KMICe2008/Pdf/500-504-CR211.pdf>
- Salleh, K. (2012). Knowledge Management in Public University: Empirical Relationships Between Learning Organization and Knowledge Management Process of Tacit Knowledge. In Knowledge Management International Conference 2012 (pp. 4–6).
- Scott, R. (2011). Benchmarking: A Literature Review, 1–14. Retrieved from https://intranet.ecu.edu.au/_data/assets/pdf_file/0010/357193/Benchmarking-Literature-Review.pdf
- Ta, A., Shahbani, M., Bakar, A., Abdullah, M. S., & Alwan, A. (2012). Requirement Analysis Approach for Universiti Utara Malaysia (UUM) Library Data Warehouse, (July), 4–6.
- Tasmin, R. (2012). Knowledge Management: An Empirical Survey On Malaysian Higher Education. Retrieved from <http://eprints.uthm.edu.my/2603/1/u.pdf>
- Tasmin, R., & Woods, P. (2007). Relationship between corporate knowledge management and the Firms innovation capability. Int. J. Services Technology and Management, 8(1), 62–79.
- Tasmin, R., & Woods, P. (2008a). Knowledge Management And Innovation In Peninsular Malaysia. In Knowledge Management International Conference 2008 (pp. 158–164).
- Tasmin, R., & Woods, P. (2008b). Knowledge Management Theories and Practices: An Empirical Survey. In KMO '2008 Third International KMO Conference (pp. 1–14). Vaasa, Finland. Retrieved from <http://kmo2008.puv.fi/>
- Tasmin, R., & Yap, L. S. (2010). Determining Factors of Knowledge Management Implementation in Knowledge-Based Organizations. In Knowledge Management International Conference 2010.
- Wai, Y. M., Ng, A., Hong, H., Din, S., & Bakar, A. (2012). Education and Training is a Key Success Factor of Knowledge Management Implementation: A Case Study. In Knowledge Management International Conference 2012 (KMICe2012) (pp. 4–6). Retrieved from <http://www.kmice.cms.net.my/ProcKMICe/KMICe2012/PDF/CR165.pdf>
- Yusoff, M. Z., Mahmuddin, M., & Ahmad, M. (2012). A Conceptual Model of Knowledge Work Productivity for Software Development Process: Quality Issues, (July), 4–6. Retrieved from <http://www.kmice.cms.net.my/ProcKMICe/KMICe2012/PDF/CR147.pdf>
- Zaim, H. (2006). Knowledge Management Implementation in IZGAZ. Journal of Economic & Social Research, 8(2), 1–25. Retrieved from <http://ezproxy.net.ucf.edu/login?url=http://search.ebscohost.com/login.aspx?direct=true&db=buh&AN=31426137&site=ehost-live>
- Zakaria, K. (2008). KM Practices in Academic Libraries of Malaysia: A Conceptual Framework. In Knowledge Management International Conference (KMICe) 2008 (pp. 69–74). Retrieved from <http://www.kmice.cms.net.my/ProcKMICe/KMICe2008/Pdf/69-74-CR58.pdf>

Knowledge Sharing Behaviour in Libraries: A Case Study of Raja Tun Uda Library Selangor, Malaysia

Azman Mat Isa, Nurul Farhana Mohd Jamal, and Nordiana Mohd Nordin

Universiti Teknologi MARA(Shah Alam), Malaysia, {azmanmi;ndiana} @salam.uitm.edu.my

ABSTRACT

Knowledge management is adopted by many organizations in order to improve their performance and gain competitive advantage. Knowledge sharing has become a crucial activity in knowledge management. Being at the core of information management, librarians should demonstrate considerable level of knowledge management practice. This study investigates factors affecting knowledge sharing behavior in a state library namely, Raja Tun Uda Library, Selangor. It aims to identify relationships between individual, organizational and technological factors with knowledge sharing behavior in the organization. Data were collected using questionnaires and analyzed using Statistical Package for Social Science version 16. The findings show that individual and technological factors have significant relationships with knowledge sharing behavior. However, there is no significant relationship between organizational factors and knowledge sharing behavior.

Keywords: knowledge management, knowledge sharing behaviour, library.

I INTRODUCTION

In the recent years, knowledge management has become prevalent in organizations to help boosting their performance. Nonaka & Takeuchi (1995) describe knowledge management as the ability of a firm to create new knowledge, spread the knowledge throughout the organization and reflect the result in its product, services and system. Knowledge management is the identification, optimization, and active management of intellectual assets, which is in the form of explicit knowledge held in artifacts or as tacit knowledge possessed by individuals or communities (Alrawi, 2008).

Knowledge management, which traditionally for profit-making organization, is meant for enhancing and improving performance in order to gain competitive advantage and increase profit of the organization. However, knowledge management can also be applied in non-profitable organizations such as government bodies in achieving their own goals (Teng & Hwamdeh, 2002). In the context of this study, the implementation of knowledge

management in non-profit organizations is still rare especially in libraries (Anna and Puspitasari, 2013).

Library is a place where information and knowledge resided. Libraries should be the best place to implement and demonstrate knowledge management, though it is easier said than done. Practicing knowledge sharing is essential for strategic planning and cultivation of knowledge management in libraries (Kumaresan, 2010). Unfortunately, not everyone is willing to share knowledge particularly when they believed the knowledge is privileged and an advantage for them. Hence, keeping it exclusively to themselves would make them remain valuable in the organization (Mobashar et al., 2011). A study by Sirajuddin, Ahmad and Rose (2006) involving 17 public universities in Malaysia found that only 29.4% of employees practiced knowledge sharing.

This finding in turn instigates an investigation on knowledge sharing in libraries as a center of information and knowledge. Therefore, libraries must demonstrate knowledge sharing in order to be exemplary in knowledge management. This study aims to investigate relationship between individual factors and knowledge sharing behavior; to identify the relationship between organizational factors and knowledge sharing behavior and; determine the relationship between technology factors and knowledge sharing behavior. This study was conducted in the Selangor Public Library Corporation, Malaysia, which is the most advanced public library in the nation.

II LITERATURE REVIEW

A. Knowledge Sharing

Knowledge is an important asset that can bring the organization to be success and ease to achieve organization goal and objective. Davenport and Prusak, 1998) describe knowledge as a fluid mix of framed experience, values, contextual information, and expert insight that provides a framework for evaluating and incorporating new experiences and information. It originates and applies in the mind of the knower's. In organizations, it often embedded not only in documents or repositories but also in organizational routines, processes, practices and norms.

Knowledge sharing is a social interaction in a culture that involves the exchange of knowledge,

experience, and skills among employees throughout the whole organization (Lin, 2007). It is an activity through which knowledge such as information, skills or expertise are exchanged among people, friends, or members of a family, a community or an organization (Wang and Noe, 2010; Noorazah and Juhana, 2011). Moreover, Wang and Noe (2010) stated that knowledge sharing refers to the provision of task information and know-how to help others and to collaborate with others to solve problems, develop new ideas, or implement policies or procedures.

Unfortunately, knowledge sharing occurs at the individual and organizational levels in which the individual aspect assumes the knowledge sharing is merely conversing with their colleagues to help them perform their tasks accordingly. Meanwhile, organizational aspects of knowledge sharing is capturing, organizing, reusing, and transferring experience-based knowledge that resides in the organization and making that available to others (Lin, 2007).

Hence, knowledge sharing can be defined as a process of communication between two or more peoples involved in the provision and acquisition of knowledge in which communication can take up many forms, either using both verbal and non-verbal mechanisms, with or without the use of technology. Knowledge can be shared not only through face-to-face interactions but also through various channels such as email, telephone, videoconference and other media. People often share knowledge unconsciously through informal interactions (Swap et al., 2001; Taminiiau, Smit and de Lange, 2009). Knowledge sharing can also occur in a conversation over a cup of coffee in which people exchanges their knowledge with the purpose of helping colleagues to get something done better and in a more efficient manner Amayah (2013).

Knowledge sharing improves the quality of service delivery of an organization particularly the public ones and these organizations are more service-oriented rather than producing product for profit (Bakhari & Zawiyah, 2010). Unfortunately, most of libraries still adopting traditional orientation concept (Anna and Puspitasari, 2013) but some of the libraries that already have more advanced vision by applying knowledge management and promoting knowledge sharing with various purposes, especially for knowledge creation among their staff, are able to produce both products and services innovation in libraries

B. Knowledge Sharing Behavior

Knowledge sharing is a key enabler of knowledge management (Nonaka & Takeuchi, 1995). Knowledge possessed by individuals and of incorporating individuals' knowledge into organizational knowledge depending on employees' knowledge sharing behavior. Knowledge sharing is a behavior when an individual disseminates their acquired knowledge to other members within an organization. It is the action of individuals in sharing their existing knowledge with others.

Knowledge sharing depends on individuals and is derived from the personal consideration such as beliefs, experiences, values, and motivation. Individuals that have enough confidence in their ability to share valuable knowledge have more chances to articulate intentions to share their knowledge as well as to give account of their higher levels of engagement in knowledge sharing (Wang and Noe, 2010). Practically, knowledge sharing cannot be forced when it is related to "people's willingness" since organizational knowledge largely resides within individuals, it remains unexposed to others until knowledge owners want to make it available (Kuo, 2013)

Numerous studies revealed knowledge sharing behavior by adapting the Theory of Planned Behavior (TPB) and Theory of Reason Action (TRA) in measured knowledge sharing behavior. Both theories are applicable in knowledge sharing researches (Bock et al., 2005).

C. Factors Influencing Knowledge Sharing

Based on the previous studies, there are three factors influencing knowledge sharing namely individual, organizational and technology. Individual factor has three dimensions, which are awareness, trust and personality. Awareness of the importance of knowledge sharing is considered as an attitude that every employee should possess, including the top management (Van de Brink, 2003). On the contrary, lack of awareness is one of the factors that affect knowledge sharing and innovation in organizations (Lee and Hong, 2014). Organizations with low awareness show that members do not understand the importance of knowledge in organization (Zaid & Chen, 2014). Trust among the member in organizations is essential as it facilitates knowledge sharing (Scarbought & Swan, 2001). Personality refers to the employee's attitude towards knowledge sharing in organization. Individual's personality can be categorized through their value, attitude, mood and emotion (Van den Brink, 2003).

Organizational factor has two dimensions namely organizational culture and, reward and recognition.

Organizational culture is one of the biggest challenges to overcome as it involves feedback, valuable contributions and participation from employees and the level of collaboration in and across organizational units, while managerial implications covers the responsibility of providing sufficient training, valuing contributions, giving affirmative feedback, participation and organizational guidelines in knowledge sharing activities for their employees (Wahlroos, 2010). Meanwhile, organizational rewards indicate organization values that shape employee behaviors to share their knowledge (Cabrera and Bonache, 1999).



Figure 1: Theoretical Framework

The third factor, technological has three dimensions namely technology infrastructure, ICT tools and ICT know-how. ICT infrastructures serve as facilitators that encourage and support knowledge sharing because they are related to the knowledge management technology used in knowledge sharing activities (Volady, 2013), and they make knowledge sharing easier and more effective. Next, ICT tools refer to the application that is available in organizations that can facilitate knowledge sharing in organizations. Then, ICT know how that can defined as the computer literacy of worker in doing their daily works. Syed Omar and Rowland (2004) mentioned that sufficient and appropriate ICT trainings to all employees have positive relationships with knowledge creation and knowledge transfer.

III METHODOLOGY

A. Instrument and Method

This study adopts a quantitative method. The instrument used for collecting data was a questionnaire. The questionnaire was developed based on an adaptation from the Theory of Reason Action (TRA) scale. There were four sections namely, demographic data; factors affecting knowledge sharing; knowledge sharing behavior and; opinion by respondents. The second and third sections are assessed using the 5-point Likert Scale ranging from 1 (strongly disagree), 2 (disagree), 3 (neutral), 4 (agree) and 5 (strongly agree).

B. Population and Sampling

This study was conducted in Selangor Public Library Corporation. Population of the study is employees of the library headquarters. It was a purposive sampling involving head of departments, librarians, assistant librarians and library officers.

C. Data Analysis

Data were analyzed using SPSS version 16. All hypotheses were tested using correlation and linear regression analysis.

D. Limitation of the Study

This study limited to the headquarters of Selangor Public Library Corporation, i.e. Raja Tun Uda Library in Shah Alam due to its key functions and reputation as the most advanced public library in Malaysia.

IV RESULT AND DISCUSSION

A. Findings and Discussion

Research finding shows there was a strong between individual factors and knowledge sharing behavior among employees in Raja Tun Uda Library, Selangor. It is evident that employees of Raja Tun Uda Library shared their knowledge depending on individuals, deriving from awareness, trust and personality. The results of this finding is consistent with the findings from previous studies by Lin (2007); Ain (2013); and Bakhari and Zawiyah (2010). This means that respondents possessed high level of awareness on the importance of knowledge sharing for the performance of the organization. There is also a significant relationship between the level of trust among respondents that motivates them to share their knowledge with others. Another dimension of individual factor is personality, which reveals that extrovert personality is significantly related to knowledge sharing behavior.

The second factor of knowledge sharing behavior is organizational which, dimensions include organizational culture, reward and recognition. Finding shows that culture is significantly related to knowledge sharing behavior. In other words,

respondents actively participated in knowledge sharing activities in Raja Tun Uda Library. This is consistent with research finding by Hoof and Huysman (2009) and Hall and Goody (2007) that organizational culture did affect knowledge sharing.

However, finding also shows that there is no relationship between reward and recognition and knowledge sharing behavior. This negative relationship is also supported by previous studies such as Bock and Kim (2002); and Watson and Hewett (2006). Bock and Kim (2002) argue that reward might be a trigger for knowledge sharing, but it was not a fundamental force in forming a person's attitude.

Hence, the management of Raja Tun Uda Library might prefer rewarding their staff through other incentives since this study found that although the management did not reward their staff with monetary incentives for their knowledge sharing practice, they did recognize their staff in other ways. It was proven by this study, based on the descriptive analysis it was found that most of the employees of Raja Tun Uda Library agreed that the management recognized their contributions and expressed gratitude for their participation in knowledge sharing activities by mentioning them in organizational annual reports, the Internet, advertisement boards and others.

The third factor of knowledge sharing behavior is technology. There are three dimensions of technology namely ICT infrastructure, ICT tools and ICT know-how. Finding shows that ICT infrastructure is significantly related to knowledge sharing behavior was accepted. In other words, this meant that the availability of ICT infrastructures at Raja Tun Uda Library influenced their knowledge-sharing activities. This is consistent with finding of research by Bakhari and Zawiyah (2010). It was impossible for organizations to embark on knowledge sharing without proper ICT infrastructures (Hasanali, 2002) as its presence particularly in the form of new technology and systems could increase technological motivation to share knowledge (Hendriks, 1999).

Research finding also shows that ICT tools is not significantly related to knowledge behavior. Raja Tun Uda Library also might not have enough ICT tools that could facilitate knowledge sharing among their staf. However, the result in this finding differed from the previous studies since Usman and Oyefolahan (2014); and Bakhari and Zawiyah (2010) found that ICT tools had a significant relationship with knowledge sharing since ICT tools that existed in organizations could help and facilitate employees to share knowledge (Syed

Omar & Rowland, 2004). Nevertheless, several of previous studies mentioned that without denying the significances of tools and technologies in supporting knowledge sharing, practical implementation proved that the mere technology did not guarantee knowledge-sharing behavior will be occurred (Ruggles, 1998; McDermott, 1999; Cross and Baird, 2000). Thus, this study concluded that ICT tools did not influence knowledge sharing behavior among employees of Raja Tun Uda Library. Possibly, staff might prefer to use offline methods in sharing their knowledge with their colleagues.

This study also discovers there is a significant relationship between ICT know-how and knowledge sharing behavior. The ability to utilize ICT influences knowledge sharing behavior among respondents in Raja Tun Uda Library. This finding is consistent with Bakhari and Zawiyah (2010) and Syed Omar & Rowland (2004) who also found a positive relationship between the two elements. This can be understood as there are various medium of communication today to facilitate sharing of knowledge. The ability to utilize ICT facilitates knowledge sharing in the organization. It is also more efficient and cost saving.

B. Suggestions

Based on the findings, few suggestions proposed to enhance knowledge sharing in Raja Tun Uda Library, namely:

i. Improve Reward and Incentive System

A more attractive rewarding and incentive system would foster knowledge sharing among employees of Raja Tun Uda Library as lacked of reward had been a major barrier to knowledge sharing across cultures (Yao, Kam & Chan, 2007). Currently, the management of Raja Tun Uda Library recognized their staff who participated and contributed to knowledge sharing by mentioning them in the annual reports and advertisement boards. Arguably, a public recognition would be the least reward, which motivates one who shared his knowledge. However, a more meaningful yet not costly reward is by considering their commitment as a key performance indicator. Their annual achievement will be an evident of their commitment in sharing their knowledge for the benefit of the organization. Definitely monetary reward would be the most meaningful incentive, but this can only be implemented if Raja Tun Uda Library generates steady profit annually, which would be unlikely for a public library.

ii. Changing the Culture

It is evident that the management of Raja Tun Uda Library encourages knowledge sharing among employees. This is a positive indicator that the management is committed to develop a culture of knowledge sharing. Management support for knowledge sharing was shown to be positively associated with employees' perceptions of a knowledge sharing culture, which included employees' trust, willingness of experts to help others and willingness to share knowledge (Connelly & Kelloway, 2003; Lin, 2007). Although it is challenging to change a culture, the commitment from the management will speed up the process which can be seen a different as early as twelve months. The process will take much longer time if it begins from lower level. In the context of Raja Tun Uda Library, it is a desirable situation as the Director of Raja Tun Uda Library is keen to implement knowledge sharing in the organization. Hence, it just a matter of time for this knowledge sharing to be a culture in Raja Tun Uda Library.

iii. Develop and Implement Knowledge Management System

Respondents admitted they usually shared their knowledge during certain event and training sessions. Previous research by Ain Zuraini (2013); Bakhari and Zawiyah (2010) and Syed Omar and Rowland (2004) proved that adoption of information systems encouraged knowledge sharing behavior among employees such as through portals and organization's website. This, however, requires careful attention as the main function of Raja Tun Uda Library is to provide services to users. Hence, striking a balance between serving users and developing a knowledge management system is essential.

V CONCLUSION

Knowledge sharing behavior is getting more apparent in Raja Tun Uda Library. This is a meaningful indicator that library should be exemplary for knowledge sharing besides providing meaningful and professional services to the society. The commitment by the management is key to ensure knowledge sharing behavior will eventually become a culture in Raja Tun Uda Library.

ACKNOWLEDGMENT

The authors wish to thank you Mdm Mastura Hj Muhammad, Director of Selangor Public Library Corporation for allowing this research conducted in Raja Tun Uda Library, the headquarters of the corporation. The authors also wish to extend gratitude to all respondents for their commitment and support in the process of accomplishing this study. It is hope that the findings of this research would be beneficial to Raja Tun Uda Library and

library and information management professionals at large.

REFERENCES

- Ain Zuraini Zin Aris (2013). Requirement for Knowledge Sharing Behavior: A Review of Empirical Findings. *Journal of Asian Scientific Research*, 3(6), 517.
- Al-Alawi, Ismail., Al-Marzooqi, Y. N., & Mohammed, Y. (2007). Organizational Culture and Knowledge Sharing: Critical Success Factors. *Journal of Knowledge Management*, 11(2), 22-42.
- Amayah, A. T. (2013). Determinants of Knowledge Sharing In a Public Sector Organization. *Journal of Knowledge Management*, 17(3), 454-471.
- Anna, V., Nove, E., & Puspitasari, D. (2013). *Knowledge Sharing In Libraries: A Case Study of Knowledge Sharing Strategies in Indonesian University Libraries*. Retrieved October 10, 2015 from <http://library.ifla.org/200/akhari> & Zawiyah (2010). The Impact of Individual Factors on Knowledge Sharing Quality. *Journal of Organizational Knowledge Management*, 13.
- Bock, G.W. et al. (2005). Behavioral Intention Formation in Knowledge Sharing: Examining: The Roles of Extrinsic Motivators, Social-Psychological Forces, and Organizational Climate. *MIS Quarterly*, 29(1), 87-111.
- Cabrera, E.F. & Bonache, J. (1999). An Expert HR System for Aligning Organizational Culture and Strategy. *Human Resource Planning*, 2 (1), 51-60.
- Connelly, C.E. & Kelloway, E.K. (2003). Predictors of Employees' Perceptions of Knowledge Sharing Culture. *Leadership & Organization Development Journal*, 24 (5), 294-301.
- Cross, R. & Baird, L. (2000). Technology is not enough: Improving performance by building organizational memory. *Management Review*, 3(41), 69-78.
- Davenport, T. H. & Prusak, L. (1998). *Working knowledge: How Organizations Manage What They Know*. Massachusetts: Harvard Business School Press.
- Hall, H. & M. Goody, 2007. KM, Culture and Compromise: Interventions to Promote Knowledge Sharing Supported By Technology in Corporate Environment. *Journal of Information Science*, 33(2), 181-188
- Hasanali, F. (2002). *Critical Success Factors of Knowledge Management*. Retrieved October 10, 2015 from http://www.providersedge.com/docs/km_articles/Critical_Success_Factors_of_KM.pdf.
- Hendriks, P. (1999). Why Share Knowledge? The Influence of ICT on the Motivation for Knowledge Sharing. *Knowledge and Process Management*, 6(2), 91-100.
- Huysman, M. & Wulf, V. (2006). IT To Support Knowledge Sharing In Communities: Toward A Social Capital Analysis. *Journal of Information Technology*, 21(1), 40-51.
- Kumaresan, S.C. (2010). Knowledge Management and Knowledge Sharing For Strategic Library Planning. Value of Knowledge Sharing For Expatriate Library Professionals. *Perspective in International Librarianship*, (4), 1-6.
- Kuo, T. H. (2013). How Expected Benefit and Trust Influence Knowledge Sharing. *Industrial Management & Data Systems*, 113(4), 506-522.
- Lin, H. F. (2007). Knowledge Sharing and Firm Innovation Capability: An Empirical Study. *International Journal of Manpower*, 28(3), 315-332.
- McDermott, R. (1999). How to Build Communities of Practice in Team Organizations: Learning Across Teams. *Knowledge Management Review*, 2(2), 32-36
- Mobashar et al. (2011). Framework to Increase Knowledge Sharing Behavior among Software Engineers. *Journal of Applied Sciences, Engineering and Technology* 7(4), 849-856.
- Nonaka, I. & Takeuchi, H. (1995). *The Knowledge Creating Company*. New York: Oxford University Press.
- Norazah, Md. N. & Juhana, S. (2011). Factors Influencing Employee Knowledge Sharing Capabilities in Electronic Government Agencies in Malaysia. *IJCSI International Journal of Computer Science Issues*, 8(4), 106-114.
- Ruggles, R. (1998). The State of the Notion: Knowledge Management in Practice. *California Management Review*, 40(3), 80-89.

- Scarbrough, H. & Swan, J (2001). *Knowledge Communities and Innovation. In Trends in Communication: Special Issues on Communities Of Practice*. Amsterdam: Boom.
- Sirajuddin, Ahmad Zaki, & Rose (2006). Knowledge Sharing Culture in Malaysian Public Institution of Higher Education: An Overview. *Proceeding of the Postgraduate Annual Research Seminar*, 354-359.
- Swap, W. et al. (2001). Using Mentoring and Storytelling to Transfer Knowledge in the Workplace. *Journal of Management Information Systems*, 18(1), 95-114.
- Syed-Ikhsan, S.O. & Rowland, F. (2004). Knowledge Management in a Public Organization: A Study on the Relationship between Organizational Elements and the Performance of Knowledge Transfer. *Journal of Knowledge Management*, 8(2), 95-111.
- Taminiau, Y., Smit, W. & de Lange, A. (2009). Innovation in Management Consulting Firms through Informal Knowledge Sharing. *Journal of Knowledge Management*, 13(1), 42-55.
- Teng, S., & Hawamdeh, S. (2002). Knowledge Management in Public Libraries. *AP*, 54(3), 188-197
- Usman, S. H., & Oyefolahan, O. (2014). Determinants of Knowledge Sharing Using Web Technologies among Students in Higher Education. *Journal of Knowledge Management, Economics and Information Technology*, 4(2), 1-9.
- Van den Brink, P. (2003). *Social, Organizational and Technological Conditions That Enable Knowledge Sharing*. PhD Thesis, Faculty of Technology, Policy and Management, Delft University of Technology. Holland.
- Volady, L. (2013). *An Investigation of Factors Influencing Knowledge Sharing among Undergraduate Teacher Education Students*. Retrieved from <http://volady0002.wordpress.com/knowledge-sharingamong-undegraduate-students/>
- Wahlroos, J. K. (2010). *Social Media as a Form of Organizational Knowledge Sharing. A Case Study on Employee Participation at Wartsila*. Helsinki: University of Helsinki.
- Wang, S. & Noe, R.A. (2010). Knowledge Sharing: A Review and Directions for Future Research. *Human Resource Management Review*, 20(2), 115-131.
- Zaid, Zainudin & Chen, S. D. (2014). Factors Affecting Knowledge Sharing Behavior among Stakeholders in Jordanian Hospitals Using Social Networks. *International Journal of Computer and Information Technology*, 3(5), 919-928.

Domain of Application in Context-Aware Recommender Systems: A Review

Khalid Haruna ^{1,2}, Maizatul Akmar Ismail ¹, and Shuhaida Mohamed Shuhidan ³

¹ University of Malaya, Malaysia, maizatul@um.edu.my

² Bayero University, Kano, Nigeria, kharuna.cs@buk.edu.ng

³ Universiti Teknologi MARA, Malaysia, shuhaida@tmsk.uitm.edu.my

ABSTRACT

The purpose of this research is to provide an exhaustive overview of the existing literature on the domain of applications in recommender systems with their incorporated contextual information in order to provide insight and future directions to practitioners and researchers. We reviewed published journals and conference proceedings papers from 2010 to 2016. The review finds that multimedia and e-commerce are the most focused domains of applications and that contextual information can be grouped into static, spatial and temporal contexts.

Keywords: Context-aware, Context, Domain of application, Recommendation.

I INTRODUCTION

Internet being the primary source of information help users to acquire information whenever, wherever, and whatever they wish, according to their interests. However, the overwhelming amount of information that is available on the internet leads to the problem of information overload, where researchers can easily get lost in finding information that may be associated with their interest (Hawalah & Fasli, 2014).

Recommender system (RS) emerged over the last decade to remediate the problem of information overload by collecting information on the preferences of its users for a set of items (Bobadilla, Ortega, Hernando, & Gutiérrez, 2013).

At the emergence of RS in the 1990s, two dimensional recommender systems were the predominant approaches in predicting users' interests. However, more recently, researchers aimed at developing systems with the ability of recommending items to users in certain circumstances, with an incorporation of contextual information into the two-dimensional recommendation process being leveraged (Panniello, Tuzhilin, & Gorgoglione, 2014).

Recommender systems become appropriate tools for facilitating and accelerating the process of information seeking. (Bobadilla et al., 2013) pointed out that developing applications is the focus of the current

recommender system researches, especially with the current age of big data.

Despite the acceptance of the concept of recommender system by many developers from different domains of applications such as music (Hariri, Mobasher, & Burke, 2012), movies (Colombo-Mendoza, Valencia-García, Rodríguez-González, Alor-Hernández, & Samper-Zapater, 2015), tourism (Teze, Gottifredi, García, & Simari, 2015), e-commerce (Panniello et al., 2014), learning (Benlamri & Zhang, 2014), news (De Pessemier et al., 2015), etc. Yet, none to our knowledge a single paper that identify the various domains of applications in recommender systems with their incorporated contextual information.

In this paper, we addresses various domains of applications and the different contextual information incorporated by the researchers in each domain. This will help in developing a generic framework that will be of maximum flexibility for all context-aware recommender systems. It may also justify whether the incorporated contextual information are well enough for recommending tailored services to users or more extensive research need to be done in such directions.

The rest of the paper is organised as follows. Section II presents related work. Our methodology is presented in section III. Section IV is the results of our review and finally the conclusion and future work are explained in section V.

II LITERATURE REVIEW

It has been a decade since the field of Computer Science embraced the concept of context-aware recommender systems (CARS) which has being researched extensively in various domain of applications such as movies, music, e-commerce, etc. Despite these numerous studies, we could not locate a paper that identify the different domains of applications with their incorporated contextual information.

(Park, Kim, Choi, & Kim, 2012) reviewed 210 articles on recommender systems from 46 journals published between 2001 and 2010. The authors examined and classified those papers by the year of publication, the journals in which they appear, their application domain, and their data mining techniques. The authors

also categorized the 210 papers into eight application fields and eight data mining techniques.

According to the review, the majority of the research papers were related to movie and shopping and least attention has been paid to image processing field. In this paper, we do not only identify the domain of applications in recommender systems but also identified their incorporated contextual information.

Journals and conferences that were published from 2000 to 2007 were also reviewed in (J.-y. Hong, Suh, & Kim, 2009) using a keyword index and article title search. The authors suggest a new classification framework of context-aware systems, which consists of five-layer architecture, concept and research layer, network layer, middleware layer, application layer and user infrastructure layer.

In the application layer, they identified five domains of applications of tower guide, information systems, communication systems, m-commerce and web services. Their work is limited to identifying the contextual information constituted in each domain.

A review has also been conducted to identify the contextual information and methods used for making recommendations in digital libraries as well as the way researchers understood and used relevant contextual information from 2001 to 2013 (Champiri, Shahamiri, & Salim, 2015). The result of their review revealed that contextual information incorporated into recommendations could be categorised into three contexts, users' contexts, document's context, and environment context. Their work is limited to the domain of digital library, however in this paper; we identify the contextual information incorporated in different domains of applications.

Recommender systems was also examined systematically into the real-world applications domains and application platforms (Lu, Wu, Mao, Wang, & Zhang, 2015). The research identified eight different major application domains: e-government, e-business, e-commerce/e-shopping, e-library, e-learning, e-tourism, e-resource service, and e-group activity. In each domain, they mentioned several typical applications: digital product (tag, TV program, webpage, document, video, movie, music, etc.), physical goods (books, bags, etc.) and tourism that focuses on attractions and destinations, while others offer tour plans that include transportation, restaurants and accommodation.

III METHODOLOGY

The purpose of this research is to identify the domains of applications in recommender systems with their incorporated contextual information by examining the journals and conference proceedings papers that were

published between 2010 and 2016 in order to provide researchers with insight and future directions.

In an attempt to perform an exhaustive search, we identify the bibliographic databases that cover the majority of journals and conference proceedings papers published in the field of computer science. These databases are ACM, IEEE, ScienceDirect, SpringerLink and Web of Science.

The searching process was performed based on the Boolean search criteria “(Context) AND (Recommender OR Recommendation)”. We extracted all the papers that mentioned context and recommender in the paper title and abstract.

We then review each paper and include only those that mentioned context and recommender in both the title and abstract and exclude any conference paper that has less than 10 citations for 2010-2013 papers and 5 citations for 2014-2016 papers.

Finally, 68 papers were selected and each paper was prudently reviewed and classified into its domain of application and exploring its incorporated contextual information.

IV RESULTS AND DISCUSSIONS

The importance of contextual information in recommender system was recognised for some time (Adomavicius & Tuzhilin, 2001), and as a result the context-aware recommender system field was formed. With the help of current technologies, researchers are able to detect the current context and activity of a user by analysing the data retrieved from different technological tools such as sensors, GPS, etc and which are used to provide personalised suggestions to users based on their recognized activities and contexts.

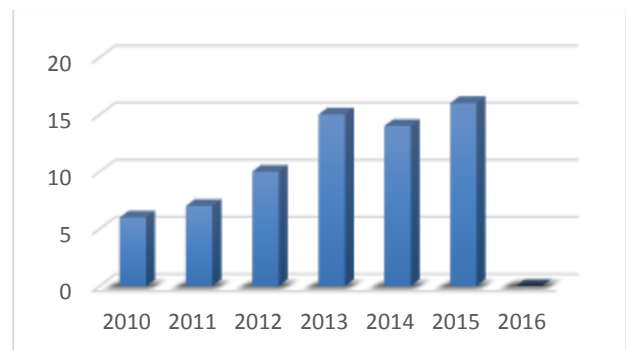

Figure 1. Distribution by Years

The distribution of the reviewed papers by year of publication from 2010 to 2016 is shown in Figure 1. It can be noted that publications related to context-aware recommender systems are increasing in an arithmetic progression. However, there is a tremendous increase in the year 2013.

From figure 1, the year 2016 has the lowest number of publications with total number of zero. This is of no

surprise as our review covers only publications between January 2010 and January 2016. It can also be inferred from figure 1 that a higher number of papers may be published at the end of 2016.

The results taken from our review showed that the domain of applications can be categorised into six

major groups (Table 1), including e-commerce, e-documents, multimedia, places, travel and tourism, and others.

Table 1 Domains of Applications with their Incorporated Contextual Information

Domain of Application	Incorporated contextual information	References
e-Commerce	URL, time of the year, current budget, mood, mental stress, gender, age, location, vicinity, category, seasonality, previous logs.	(Castro-Schez, Miguel, Vallejo, & López-López, 2011; Chan, Chiu, & Yu, 2011; Faraone, Gorgoglione, Palmisano, & Panniello, 2012; Guo, Zhang, Thalmann, & Yorke-Smith, 2014; Li, Chou, & Lin, 2014; Lin, 2014; Lombardi, Gorgoglione, & Panniello, 2013; Panniello et al., 2014; Shi, Ghedira, & Marini, 2015)
e-Documents	Activity, background, technology, environment, device, time of the day, URL, gender, age, previous logs. Book (ISBN, title, author, publisher, date classification, description, keywords, format, language), Paper (title, authors, abstracts, keywords, URL, introduction main idea, conclusion, description, type of paper (journal, conference proceedings).	(Benlamri & Zhang, 2014; De Giusti, Villarreal, Vosou, & Martínez, 2010; De Pessemier et al., 2015; Hahn, 2011; Herlocker, Jung, & Webster, 2012; Lutz, Thönssen, & Witschel, 2013; Yoshikane & Itsumura, 2013; Zarrinkalam & Kahani, 2013; Zeng et al., 2012)
Multimedia	Location, crowd, time, mood, social, companion, mental stress, orientation, weather, age, gender, sensory data.	(Alhamid, Rawashdeh, Al Osman, Hossain, & El Saddik, 2015; Alhamid, Rawashdeh, Dong, et al., 2015; Chen et al., 2010; Colombo-Mendoza et al., 2015; Durán, Laitakari, Pakkala, & Perälä, 2010; Gallego, Woerndl, & Huecas, 2013; Gantner, Rendle, & Schmidt-Thieme, 2010; Hariri et al., 2012; Hussein, Linder, Gaulke, & Ziegler, 2014; Zheng, Mobasher, & Burke, 2014)
Places	Current time, distance to available point of interest, companion, intent, nationality, location, current activity,	(Biancalana, Gasparetti, Micarelli, & Sansonetti, 2013; Gallego et al., 2013; Hussein et al., 2014; Levi, Mokryn, Diot, & Taft, 2012; Woerndl, Huebner, Bader, & Gallego-Vico, 2011; Yuan, Cong, Zhao, Ma, & Sun, 2015; Zheng et al., 2014)
Travel and Tourism	Time, location, companion, vicinity, social relations, current situation, intent, nationality, seasonality, budget.	(Bagci & Karagoz, 2015; De Pessemier, Dooms, & Martens, 2014; Gavalas, Konstantopoulos, Mastakas, & Pantziou, 2014; Teze et al., 2015; Zheng et al., 2014)
Others	Time, seasonality, sequentiality, role	(Bouneffouf, Bouzeghoub, & Gancarski, 2012; Codina, Ricci, & Ceccaroni, 2015; Gedikli & Jannach, 2013; Hidasi, 2015; Hidasi & Tikk, 2015; L. Hong et al., 2015; Liu & Aberer, 2013; Wang et al., 2012; Yan, Guo, & Cheng, 2011; Yang, Long, Smola, Zha, & Zheng, 2011)

Distribution of research papers by application fields is represented in figure 2. The majority of the research papers were related to multimedia (19 out of 68 papers, or 27.9%) and e-commerce (15 out of 68 papers, or 22.1%). This is because at the emergence of recommender system, multimedia (movie and music) and e-commerce have the higher number of practical applications than any other field.

Additionally, by having Movielens and LastFm as datasets for both movies and music respectively, encourage a development of applications in multimedia domain. It can be noted that travel and tourism scored the least number of publications (5 out of 68 papers, or 7.4%). However, from the review it can be noted that travel and tourism is a new concept that is now taking much attention in recommender systems, as the five publications are between 2014 and 2015.

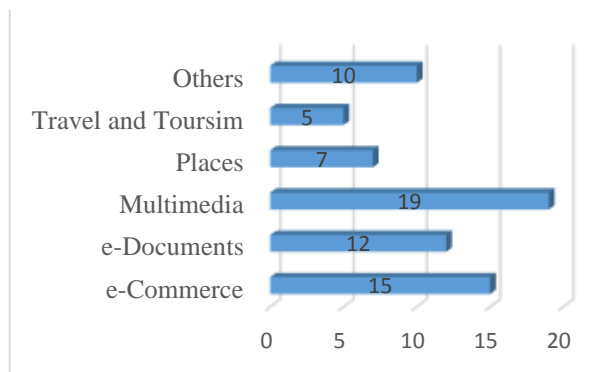

Figure 2 Distribution By Domain Of Applications

Many researches focus on incorporating context into the recommendation process in different domains of applications with different contextual information. From our review, the contextual information adopted by researchers can be categorised into static, spatial and temporal contexts.

Static contexts. The static contexts are the contextual information that do not usually change over a period of time, but have an effect on the recommendation process. These are fixed information, such as age, identity, name, gender and other user profile information, including personal or demographic information and other generic interests that do not usually change over time.

Spatial contexts. The spatial contexts are the contextual information that formalise the environmental or geographical situation of both the users seeking recommendation and the items to be recommended. The most common example of this category is the location of the user and/or the item.

Temporal contexts. Temporal contexts are the contextual information that are meant for a

temporary period. These are the dynamic contexts, such as the current goal, mood, location, situation, time, activity, choice, and social relation of a user seeking recommendations.

V CONCLUSION AND FUTURE WORK

This paper presents an extensive overview of the researches conducted on context-aware recommender systems. The theoretical contribution of our work is twofold. Firstly, we classified the previous researches according to their domain of applications and their incorporated contextual information. Next, our review revealed that the contextual information incorporated in recommender systems could be grouped into static, spatial and temporal contexts.

From our review, multimedia and e-commerce are the most focused domains of applications and that researchers usually incorporate one or two contextual information into the recommendation process, and the recommendation is either for a single individual or a set of the same items.

Therefore, we propose the need for an extensive research on developing a more flexible framework that will be used to incorporate as many contextual information as possible into the recommendation process and the recommendation should also cover group recommendations. We hope for this review to provide researchers and practitioners with some insight on the trend in the field of context aware recommendation systems.

ACKNOWLEDGMENT

We warmly thank our colleagues for their valuable support and assistance. This research is supported by UM Research Grant No. RP028B-14AET.

REFERENCES

- Adomavicius, G., & Tuzhilin, A. (2001). Extending recommender systems: A multidimensional approach. Paper presented at the Proceedings of the International Joint Conference on Artificial Intelligence (IJCAI-01), Workshop on Intelligent Techniques for Web Personalization (ITWP2001), Seattle, Washington, August.
- Alhamid, M. F., Rawashdeh, M., Al Osman, H., Hossain, M. S., & El Saddik, A. (2015). Towards context-sensitive collaborative media recommender system. *Multimedia Tools and Applications*, 74(24), 11399-11428.
- Alhamid, M. F., Rawashdeh, M., Dong, H., Hossain, M. A., Alelaiwi, A., & El Saddik, A. (2015). RecAm: a collaborative context-aware framework for multimedia recommendations in an ambient intelligence environment. *Multimedia Systems*, 1-15.
- Bagci, H., & Karagoz, P. (2015). Context-aware location recommendation by using a random walk-based approach. *Knowledge and Information Systems*, 1-20.
- Benlamri, R., & Zhang, X. (2014). Context-aware recommender for mobile learners. *Human-centric Computing and Information Sciences*, 4(1), 1-34. doi:10.1186/s13673-014-0012-z
- Biancalana, C., Gasparetti, F., Micarelli, A., & Sansonetti, G. (2013). An approach to social recommendation for context-aware mobile services. *ACM Transactions on Intelligent Systems and Technology (TIST)*, 4(1), 10.

- Bobadilla, J., Ortega, F., Hernando, A., & Gutiérrez, A. (2013). Recommender systems survey. *Knowledge-Based Systems*, 46, 109-132.
- Bouneffouf, D., Bouzeghoub, A., & Gancarski, A. L. (2012). Following the user's interests in mobile context-aware recommender systems: The hybrid-E-greedy algorithm. Paper presented at the Advanced Information Networking and Applications Workshops (WAINA), 2012 26th International Conference on.
- Castro-Schez, J. J., Miguel, R., Vallejo, D., & López-López, L. M. (2011). A highly adaptive recommender system based on fuzzy logic for B2C e-commerce portals. *Expert Systems with Applications*, 38(3), 2441-2454.
- Champiri, Z. D., Shahmiri, S. R., & Salim, S. S. B. (2015). A systematic review of scholar context-aware recommender systems. *Expert Systems with Applications*, 42(3), 1743-1758.
- Chan, W. K., Chiu, Y. Y., & Yu, Y. T. (2011). A web search-centric approach to recommender systems with URLs as minimal user contexts. *Journal of Systems and Software*, 84(6), 930-941.
- Chen, Z., Cao, J., Song, Y., Guo, J., Zhang, Y., & Li, J. (2010). Context-oriented web video tag recommendation. Paper presented at the Proceedings of the 19th international conference on World wide web.
- Codina, V., Ricci, F., & Ceccaroni, L. (2015). Distributional semantic pre-filtering in context-aware recommender systems. *User Modeling and User-Adapted Interaction*, 1-32.
- Colombo-Mendoza, L. O., Valencia-García, R., Rodríguez-González, A., Alor-Hernández, G., & Samper-Zapater, J. J. (2015). Recometz: A context-aware knowledge-based mobile recommender system for movie showtimes. *Expert Systems with Applications*, 42(3), 1202-1222.
- De Giusti, M. R., Villarreal, G. L., Vosou, A., & Martínez, J. P. (2010). An ontology-based context aware system for selective dissemination of information in a digital library. *arXiv preprint arXiv:1005.4008*.
- De Pessemier, T., Courtois, C., Vanhecke, K., Van Damme, K., Martens, L., & De Marez, L. (2015). A user-centric evaluation of context-aware recommendations for a mobile news service. *Multimedia Tools and Applications*, 1-29.
- De Pessemier, T., Dooms, S., & Martens, L. (2014). Context-aware recommendations through context and activity recognition in a mobile environment. *Multimedia Tools and Applications*, 72(3), 2925-2948.
- Durán, J. I., Laitakari, J., Pakkala, D., & Perälä, J. (2010). A user meta-model for context-aware recommender systems. Paper presented at the Proceedings of the 1st International Workshop on Information Heterogeneity and Fusion in Recommender Systems.
- Faraone, M. F., Gorgoglione, M., Palmisano, C., & Panniello, U. (2012). Using context to improve the effectiveness of segmentation and targeting in e-commerce. *Expert Systems with Applications*, 39(9), 8439-8451.
- Gallego, D., Woerndl, W., & Huecas, G. (2013). Evaluating the impact of proactivity in the user experience of a context-aware restaurant recommender for Android smartphones. *Journal of Systems Architecture*, 59(9), 748-758.
- Gantner, Z., Rendle, S., & Schmidt-Thieme, L. (2010). Factorization models for context-/time-aware movie recommendations. Paper presented at the Proceedings of the Workshop on Context-Aware Movie Recommendation.
- Gavalas, D., Konstantopoulos, C., Mastakas, K., & Pantziou, G. (2014). Mobile recommender systems in tourism. *Journal of Network and Computer Applications*, 39, 319-333.
- Gedikli, F., & Jannach, D. (2013). Improving recommendation accuracy based on item-specific tag preferences. *ACM Transactions on Intelligent Systems and Technology (TIST)*, 4(1), 11.
- Guo, G., Zhang, J., Thalmann, D., & Yorke-Smith, N. (2014). Leveraging prior ratings for recommender systems in e-commerce. *Electronic Commerce Research and Applications*, 13(6), 440-455.
- Hahn, J. (2011). Location-based recommendation services in library book stacks. *Reference Services Review*, 39(4), 654-674.
- Hariri, N., Mobasher, B., & Burke, R. (2012). Context-aware music recommendation based on latent topic sequential patterns. Paper presented at the Proceedings of the sixth ACM conference on Recommender systems.
- Hawalah, A., & Fasli, M. (2014). Utilizing contextual ontological user profiles for personalized recommendations. *Expert Systems with Applications*, 41(10), 4777-4797. doi:10.1016/j.eswa.2014.01.039
- Herlocker, J., Jung, S., & Webster, J. G. (2012). Collaborative filtering for digital libraries.
- Hidasi, B. (2015). Context-aware Preference Modeling with Factorization. Paper presented at the Proceedings of the 9th ACM Conference on Recommender Systems.
- Hidasi, B., & Tikk, D. (2015). Speeding up ALS learning via approximate methods for context-aware recommendations. *Knowledge and Information Systems*, 1-25.
- Hong, J.-y., Suh, E.-h., & Kim, S.-J. (2009). Context-aware systems: A literature review and classification. *Expert Systems with Applications*, 36(4), 8509-8522.
- Hong, L., Zou, L., Zeng, C., Zhang, L., Wang, J., & Tian, J. (2015). Context-Aware Recommendation Using Role-Based Trust Network. *ACM Transactions on Knowledge Discovery from Data (TKDD)*, 10(2), 13.
- Hussein, T., Linder, T., Gaulke, W., & Ziegler, J. (2014). Hybreed: A software framework for developing context-aware hybrid recommender systems. *User Modeling and User-Adapted Interaction*, 24(1-2), 121-174.
- Levi, A., Mokryn, O., Diot, C., & Taft, N. (2012). Finding a needle in a haystack of reviews: cold start context-based hotel recommender system. Paper presented at the Proceedings of the sixth ACM conference on Recommender systems.
- Li, Y.-M., Chou, C.-L., & Lin, L.-F. (2014). A social recommender mechanism for location-based group commerce. *Information Sciences*, 274, 125-142.
- Lin, Z. (2014). An empirical investigation of user and system recommendations in e-commerce. *Decision Support Systems*, 68, 111-124.
- Liu, X., & Aberer, K. (2013). SoCo: a social network aided context-aware recommender system. Paper presented at the Proceedings of the 22nd international conference on World Wide Web.
- Lombardi, S., Gorgoglione, M., & Panniello, U. (2013). The effect of context on misclassification costs in e-commerce applications. *Expert Systems with Applications*, 40(13), 5219-5227.
- Lu, J., Wu, D., Mao, M., Wang, W., & Zhang, G. (2015). Recommender system application developments: A survey. *Decision Support Systems*, 74, 12-32.
- Lutz, J., Thönissen, B., & Witschel, H. F. (2013). Breaking free from your information prison.
- Panniello, U., Tuzhilin, A., & Gorgoglione, M. (2014). Comparing context-aware recommender systems in terms of accuracy and diversity. *User Modeling and User-Adapted Interaction*, 24(1-2), 35-65.
- Park, D. H., Kim, H. K., Choi, I. Y., & Kim, J. K. (2012). A literature review and classification of recommender systems research. *Expert Systems with Applications*, 39(11), 10059-10072.
- Shi, F., Ghedira, C., & Marini, J.-L. (2015). Context Adaptation for Smart Recommender Systems. *IT Professional*, 17(6), 18-26.
- Teze, J. C., Gottifredi, S., García, A. J., & Simari, G. R. (2015). Improving argumentation-based recommender systems through context-adaptable selection criteria. *Expert Systems with Applications*, 42(21), 8243-8258.
- Wang, J., Zeng, C., He, C., Hong, L., Zhou, L., Wong, R. K., & Tian, J. (2012). Context-aware role mining for mobile service recommendation. Paper presented at the Proceedings of the 27th Annual ACM Symposium on Applied Computing.
- Woerndl, W., Huebner, J., Bader, R., & Gallego-Vico, D. (2011). A model for proactivity in mobile, context-aware recommender systems. Paper presented at the Proceedings of the fifth ACM conference on Recommender systems.
- Yan, X., Guo, J., & Cheng, X. (2011). Context-aware query recommendation by learning high-order relation in query logs. Paper presented at the Proceedings of the 20th ACM international conference on Information and knowledge management.

- Yang, S.-H., Long, B., Smola, A. J., Zha, H., & Zheng, Z. (2011). Collaborative competitive filtering: learning recommender using context of user choice. Paper presented at the Proceedings of the 34th international ACM SIGIR conference on Research and development in Information Retrieval.
- Yoshikane, F., & Itsumura, H. (2013). Book recommendation based on library loan records and bibliographic information.
- Yuan, Q., Cong, G., Zhao, K., Ma, Z., & Sun, A. (2015). Who, Where, When, and What: A Nonparametric Bayesian Approach to Context-aware Recommendation and Search for Twitter Users. *ACM Transactions on Information Systems (TOIS)*, 33(1), 2.
- Zarrinkalam, F., & Kahani, M. (2013). SemCiR: A citation recommendation system based on a novel semantic distance measure. *Program*, 47(1), 92-112.
- Zeng, C., Jia, D., Wang, J., Hong, L., Nie, W., Li, Z., & Tian, J. (2012). Context-aware social media recommendation based on potential group. Paper presented at the Proceedings of the 1st International Workshop on Context Discovery and Data Mining.
- Zheng, Y., Mobasher, B., & Burke, R. (2014). Context recommendation using multi-label classification. Paper presented at the 2014 IEEE/WIC/ACM International Joint Conferences on Web Intelligence (WI) and Intelligent Agent Technologies (IAT).

System Requirement Specifications for A Semantic Knowledge Management System for Collaborative Learning Environment

Zaihisma Che Cob, Rusli Abdullah, Sulfeeza Mohd. Drus, Nor'ashikin Ali

Universiti Tenaga Nasional(UNITEN), Malaysia, zaihisma@uniten.edu.my

ABSTRACT

In this study, a Semantic KMS Model is formulated to support collaborative learning environment based on ontology. A comprehensive review was conducted to identify the important components of existing models in Knowledge Management (KM), KMS and semantic areas, and a survey was conducted to finalize the important components of the proposed model. As a result, the proposed semantic KMS model consisted of six important components to support collaborative works; KM Processes, Ontology-based Knowledge Model, Semantic KM Features, Knowledge Quality, System Quality and KM Goals. A prototype, called Semantic KMS for Collaborative Learning was developed to illustrate how the model components are supporting KM processes in collaborative works based on the system requirement specifications described in this paper. The required modules of the semantic KMS are described in details and the ontology-based knowledge models are also presented.

Keywords: knowledge management systems, semantic knowledge management

I INTRODUCTION

In modern years, Information Technology (IT) adoption in organizations to support knowledge processes has been recognized as one of the significant KM enablers, and knowledge management system (KMS) is acknowledged as one of the most successful tools to facilitate knowledge management projects (Maier & Hädrich, 2011). This recognition resulted in surge in the augmentation of sophisticated KMS for handling organizational knowledge assets. There are various definitions of knowledge management system found in the literature and one of them proposed by Davenport, De Long and Beers (1998) that describe KMS as a technology based system that supports KM processes including knowledge creation, capture, storage and knowledge dissemination and sharing. This means that if the knowledge users fail to locate the knowledge that they need, then the KMS is not successful in meeting its user's expectation, hence is not effective to support knowledge needs of its users.

Today, as online information is growing at exponential rate and massive information collected which resulted from various business activities, the task of finding and using information becoming more difficult than ever. Especially to large and distributed organizations, it is harder for them to exploit their knowledge assets without the right KMS features designed to solve their knowledge related problems. Current KMS still requires much of human efforts to access information, extract and filter information relevant to their knowledge needs (Davies, Grobelnik, & Mladeni, 2009; Che Cob & Abdullah, 2008; Davies, Lytras, & Sheth, 2007; Fensel et al., 2000). Several studies have been conducted to discuss the limitations with current KMS related to technical issues such as the KMS architecture design and infrastructural requirements for such system. For instance, the research conducted by Joo (2006) indicated two main limitation factors in current KMS; system quality and knowledge quality. Joo (2006) proposed the recent technology of Semantic Web to overcome the limitations with existing KMS, similar with several projects proposed in the literature (Apostolski et al., 2010; Davies et al., 2007; Joo & Lee, 2009; Schaffert, 2006; Stojanovic & Handschuh, 2002; Vega-Gorgojo et al., 2010).

A preliminary model of Semantic KMS for Collaborative Learning Environment has been proposed and discussed in Che Cob, Abdullah, Risidi, & Mohd Nor (2015). The model components are then verified through a survey. The verified model is then used as the blueprint in designing and developing a system prototype called Semantic KMS for collaborative Learning (SKMSCL). In this chapter, the system requirement specifications of the prototype to be developed to support the KM activities in collaborative learning environment is described.

Critical to the semantic based KMS is the ontology that is used to describe the domain knowledge related to teaching and learning processes that enable the semantic capabilities of the KMS to facilitate the KM processes in collaborative environment. The ontology is modelled using Protégé ontology editor.

II SEMANTIC KNOWLEDGE MANAGEMENT SYSTEMS FOR COLLABORATIVE LEARNING ENVIRONMENT

The recent technology of the Semantic Web has given a new drive to the old knowledge management research field. The goal is to build a unified information medium that is both understandable for people and computers thus allows the computers to do certain tasks on behalf of human users (Berners-Lee, Hendler, & Lassila, 2001). The development of Semantic Web has created many opinions and dialogue on the impact of associated technologies such as XML and RDF for developing effective and efficient KMS.

One of the major components of the Semantic Web is ontology. An ontology must be constructed for each domain of human knowledge to provide meaningful description about the knowledge of that particular domain. The use of ontologies in the science community determines ultimate success for the Semantic Web (de Bruijn et al., 2006). On the Semantic Web, data is annotated using ontologies to describe background information that enriches the description of the data, hence providing contextual information about specific data. Because ontologies are shared specifications, they can be used for several data sources including Web documents and relational databases. This enables a certain degree of inter-operation between multiple data sources (de Bruijn et al., 2006) and provide meaning to content of Web documents through its structure, hence enabling software agents to perform sophisticated tasks for human users (Berners-Lee, Hendler, & Lassila, 2001).

III RESEARCH METHODOLOGY

This research design comprises of five main phases and their research activities (as shown in Figure 1). The first phase of literature review provides critical analysis of the in depth review of current literature related to the topics of study. A comparison study has been performed on several KMS models to critically analyze and identify the important components of KMS.

The second phase, a preliminary study consisted of the activities conducted to investigate the current problems of the study to support the research gap identified in phase 1 and to identify the important components of the proposed model. A preliminary semantic KMS Model for collaborative learning environment is proposed based on the LR. In phase 2, a questionnaire was developed based on the identified constructs in phase 1. In this phase, a survey has been conducted at selected Higher Learning Institutions (HLI) in Malaysia to study the limitations of current

KMS at the HLIs and to identify important KM components to manage knowledge to support collaborative works in this domain. Before the actual data collection is performed, a pilot study was conducted to validate the survey questionnaire items. Rasch measurement model (RUMM) is used to analyze and to determine reliability of respondents and items and also to determine the outliers for both respondents and items. Based on the pilot study results, the questionnaire is then modified and the final questionnaire items is used in the actual data collection to verify the proposed components of the model. The analysis of the actual study such as regression analysis is conducted using SPSS 23.

In the third phase, the preliminary model is then modified according to the findings from phase 2. A final model is then proposed in this phase and served as the blueprint in translating the proposed model into a workable prototype (Phase 4) named Semantic KMS for Collaborative Learning (SKMSCL). The prototype is then used to validate the proposed model through a post-implementation survey. The final phase, model evaluation and discussion discusses the findings of the study based on the evaluation goals and criteria defined.

This paper shall discuss system requirement specifications of the development of the SKMSCL in Phase 4 of the research methodology (Figure 1).

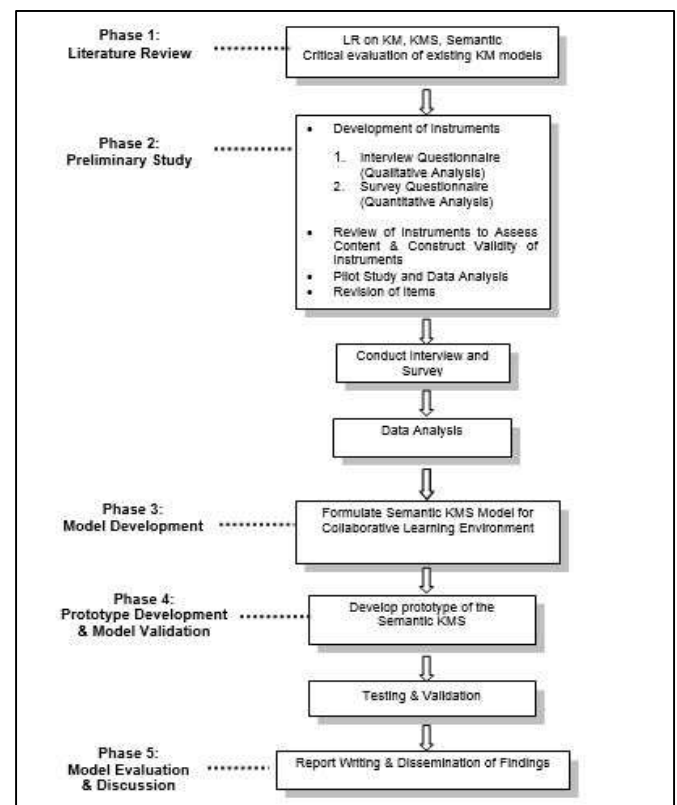

Figure 1. Research Methodology and Main Research Activities

IV A PROPOSED SEMANTIC KNOWLEDGE MANAGEMENT MODEL FOR COLLABORATIVE LEARNING ENVIRONMENT

The semantic KMS model is developed in the third phase as stated in the research methodology. The aims of this research is to establish a semantic KMS Model to guide the development of an effective KMS to ensure that successful implementation of KM initiative to support collaborative learning environment. The model exploits semantic relationships of an OWL-based ontology that provides the semantic features for KMS which leads to effective data management and enhanced collaborative environment for knowledge users.

We propose the research model shown in Figure 2 based on DeLone and McLean's IS success model (DeLone & McLean, 1992) and a model of KMS limitation factors proposed by Joo & Lee (2009). DeLone & McLean model has been used by many researchers to evaluate IS success in organizations and the application varies in many different contexts. Whilst the model of KMS limitation provides the characteristics of KMS and suggested an approach in applying semantic to the KMS.

DeLone & McLean model suggests that IS success can be assessed using three different levels and six interrelated dimensions. They proposed that system quality and information quality have impact on user satisfaction and system usage. Consequently, these

will results in impact on individual user, which in turn will be reflected in the organization as well.

Meanwhile, Joo & Lee, (2009) proposed a reverse perspective of DeLone & McLean success model and suggested limitation factors of system quality and knowledge quality as the two main factors that affect user dissatisfaction of KMS. They proposed four factors related to system quality: 1) Time/Space; 2) Inconvenience, 3) Knowledge Search and 4) Knowledge Integration, and two factors related to knowledge quality: 1) incongruence/ incompleteness of knowledge and 2) untrustworthiness of knowledge.

As shown in the Figure 2, there are six important components synthesized from the LR and the survey conducted. The Ontology-based Knowledge Model realized the semantic KM features such as semantic knowledge search, knowledge filtering and personalization. The semantic features of KMS have significant impact on the system quality which facilitate the KM processes hence achieve the KM goals. Similarly, the Ontology-based Knowledge Model also increase the knowledge quality in the KMS, which contributes to better utilization of knowledge in the KMS and facilitate the achievement of KM Goals. The entire collaboration processes are enhanced when the KMS is built on quality knowledge with semantic capabilities. The Knowledge Quality and System Quality influence the facilitation of the KM Process hence achieved the KM Goals of the specific organization.

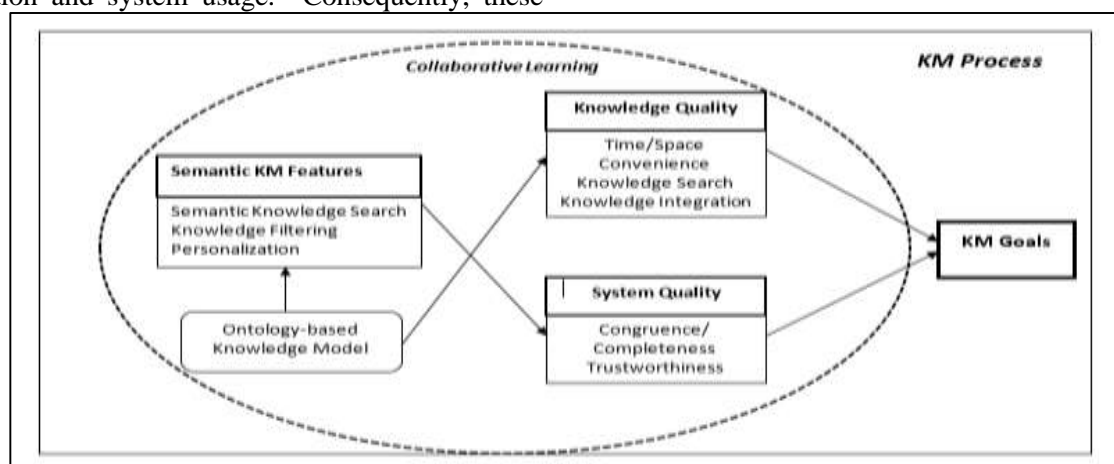

Figure 2. Semantic KMS Model for Collaborative Learning Environment

V SYSTEM REQUIREMENTS SPECIFICATION FOR SKMSCL

Semantic Knowledge Management System for Collaborative Learning (SKMSCL) is an ontology based system designed to manage knowledge to provide collaborative learning environment to support Community of Practice (CoP). The system is based on a Semantic Knowledge Management Model for Collaborative Learning as shown in Figure 2.

The system need to support four main processes of managing knowledge: i) Knowledge Acquisition, ii) Knowledge Storage, iii) Knowledge Dissemination and iv) Knowledge Application. There are several types of knowledge need to be acquired, which are knowledge of a teacher, knowledge of a student and also knowledge of a course.

The semantic capability of this system is realized through the use of ontology for knowledge model. Ontology based knowledge models (teacher's model,

student's model and course model) define the structure of the acquired knowledge to be stored in the knowledge repositories. The ontology describes the knowledge objects which provides meaning to the computer that enables computer to understand the objects, hence results in semi/ automation of certain knowledge management system (KMS) functions.

Adding the semantic to KMS will be able to answer important knowledge management questions such as know-what, know-why, know-how, know-who and know-when. Semantic KMS features provides shared description, common understanding of the knowledge objects. These shared descriptions will allow integration of knowledge across platforms (Knowledge integration). Knowledge search allows the KMS user to search the metadata rather than using keyword-based search, hence enable the system to provide more accurate search results which will reduce the user efforts to filter the relevant knowledge that they need. SKMSCL will be able to filter the knowledge to relevant KMS users (who might be interested with specific knowledge (know-who; know-what) whenever they need it (know-when). It allows personalization of knowledge that tailor to KM user's preferences and needs (based on ontology based user's model in knowledge repository).

A. System Feature for Knowledge Repositories Module

The repositories consists of teacher profile ontology, student profile ontology, learning objects for courses and course ontology. This feature is considered as high priority in order to provide the semantic capability for the system and important to allow for richer learning experience to the students.

i. Course Ontology

Course model consists of three categories of data

Course_name, Course_id, Course_credit,
Course_prereq, Course_assessments, Course_Dept,
Course_Programs, Course_Teacher

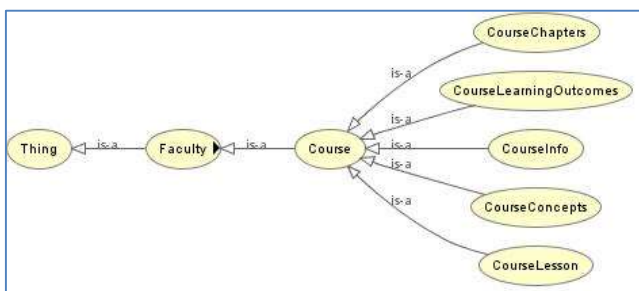

Figure 3. Course ontology

ii. Teacher Ontology

Teacher model consists of two categories of data (shown in Figure 4):

Teacher's demographic data:

Teacher_Name, Teacher_id, Teacher_age,
Teacher_address, Teacher_email, Teacher_officeNo,
Teacher_phone

Teacher's background data:

Teacher_qualifications, Teacher_researchInterests,
Teacher_Skills

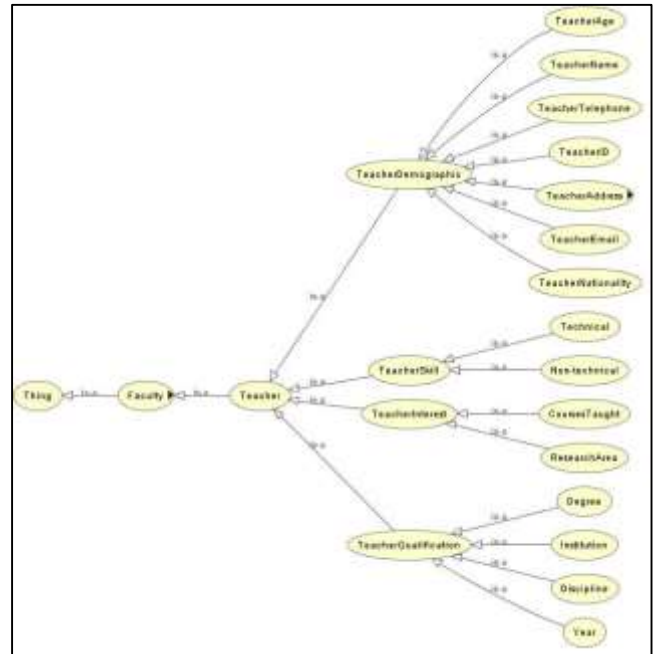

Figure 4. Teacher Ontology

iii. Student ontology

Student model consists of three categories of data (shown in Figure 5):

Student's demographic data:

Student_Demographic:
Student_name, Student_id, Student_age,
Student_address, Student_email, Student_phone

Student's academic data:

Student_Academic:
Student_Program, Student_Majoring, Student_Year,
Student_GPA, Student_CGPA,
Student_Classes_Taken

Student's Learning Experience:

Student_Competence_Level, Student_Interests

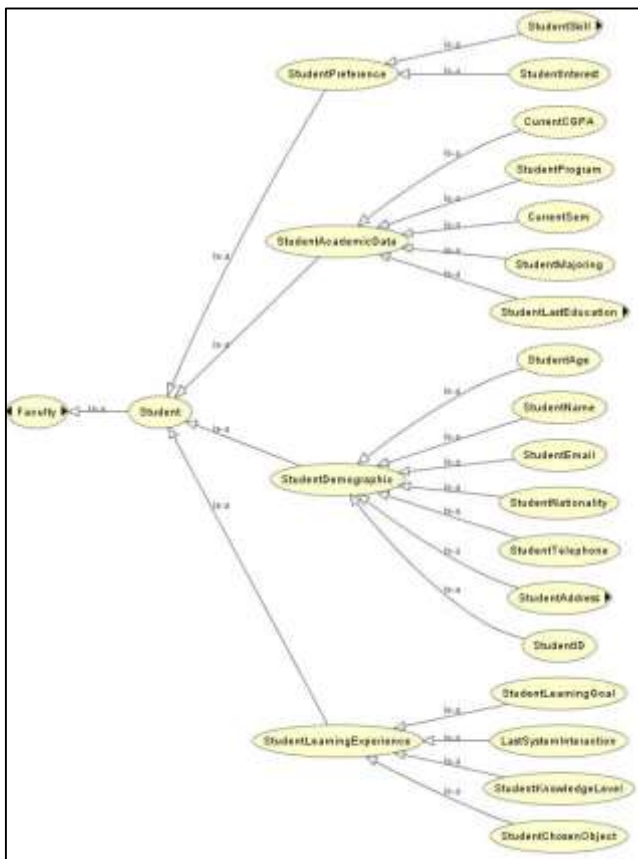

Figure 5. Student Ontology

B. System Feature for Content Management Module

The content management module allows the teacher to manage their profile, design course, manage course assessments, and view students' profiles.

i. Manage Profile

Teacher can manage their profile such as edit their research interests and skills and courses taught.

ii. Design Course

Teacher can design their course such as setting the course learning outcomes, define the course assessments and also the course delivery strategy (lecture, lab, etc.)

Teacher can manage course contents and view existing course ontology in the knowledge repositories. Teacher can edit the existing course ontology. Course content editing can be done by subject matter experts (teachers who are assigned by system administrator as the experts in specific subjects/courses). The course coordinator need to approve the edited course ontology before it will be saved and stored in the knowledge repositories.

iii. Manage Assessments

Teacher can manage the course assessments such as set the assessments questions (the objective questions only for automatic grading and tracking).

iv. View students' Profiles

Teacher can view the profiles of students registered for their course.

C. System Feature Learner's Experience Module

The Learners' Experience Module consists of features such as manage student profile, view course, take assessment, give feedback and collaborate.

i. Manage student profile

Student can edit their profile such as edit interests and contact information. Students are not allowed to edit demographic data.

ii. View Course

Student can view the course resources according to topics and course concepts as defined in the course ontology.

iii. Take Assessment

Student can take the assessment after they have learned the topics of a course. Prior to that, teacher need to assign the course topic to assess the students' mastery of a topic. The assessment score will be automatically calculated and presented to the student after the student completed an assessment. If the student do not achieve a passing mark (e.g 50%) the students will need to re-take the assessment and cannot proceed to the next topic of a specific course.

iv. Give Feedback

Student can give feedback to the course teacher through email (private message) or discussion board (public message).

v. Collaborate

Student can collaborate and discuss with the course mates about a specific course topic through a discussion board.

D. System Feature for Knowledge Search Module

The knowledge search module consists of the knowledge discovery features. The search allows student to perform simple search (search by course) and complex search (metadata search). The ontology knowledge models are important component for this module to find the relationship between knowledge objects in the repository. The result will be presented to the user according to user profile (personalization).

VI CONCLUSION

This research proposes a Semantic KMS model for collaborative learning environment to guide the development of KMS to facilitate KM processes in organizations. The proposed model consisted of six important components as critical elements for implementing KMS to support collaborative work; KM processes, ontology-based knowledge model, semantic KM features, knowledge quality, system quality and KM goals. The proposed model is then translated into a prototype called Semantic KMS for collaborative Learning (SKMSCL) based on the system requirements specification discussed in this paper. The SKMSCL prototype is then used to validate the proposed model.

REFERENCES

- Apostolski, V., Stojanov, R., Jovanovik, M., & Trajanov, D. (2010). Use of semantic web technologies in knowledge management. In *The 7th International Conference for Informatics and Information Technology (CIIT 2010)*.
- Berners-Lee, T., Hendler, J., & Lassila, O. (2001). The semantic web. *Scientific American*, 284(5), 28–37. Retrieved from <http://www.wi-consortium.org/wicweb/pdf/wi-hendler.pdf>
- Che Cob, Z., & Abdullah, R. (2008). Ontology-based Semantic Web Services framework for Knowledge Management System. In *2008 International Symposium on Information Technology*.
- Che Cob, Z., Abdullah, R., Risidi, H., & Mohd Nor, M. Z. (2015). Preliminary Study on Semantic Knowledge Management Model for Collaborative Learning. *ARPN Journal of Engineering and Applied Sciences*, 10(2), 442–450.
- Davies, J., Grobelnik, M., & Mladeni, D. (2009). Introduction to Semantic Knowledge Management, 1–2.
- Davies, J., Lytras, M., & Sheth, A. P. (2007). Guest Editors' Introduction: Semantic-Web-Based Knowledge Management. *IEEE Internet Computing*, 11(5), 14–16.
- De Bruijn, J., Ehrig, M., Feier, C., Martíns-Recuerda, F., Scharffe, F., & Weiten, M. (2006). Ontology Mediation, Merging, and Aligning. *Semantic Web Technologies: Trends and Research in Ontology-Based Systems*, 95–113. <http://doi.org/10.1002/047003033X.ch6>
- Fensel, D., Harmelen, F. Van, Klein, M., Akkermans, H., Schnurr, H., Studer, R., ... Davies, J. (2000). On-To-Knowledge : Ontology-based Tools for Knowledge Management. In *Proceedings of the eBusiness and eWork* (pp. 18–20).
- Joo, J., & Lee, S. M. (2009). Adoption of the Semantic Web for overcoming technical limitations of knowledge management systems. *Expert Systems with Applications*, 36(3), 7318–7327. <http://doi.org/10.1016/j.eswa.2008.09.005>
- Schaffert, S. (2006). IkeWiki: A Semantic Wiki for Collaborative Knowledge Management. In *15th IEEE International Workshops on Enabling Technologies: Infrastructure for Collaborative Enterprises (WETICE '06)* (pp. 388–396). Ieee. <http://doi.org/10.1109/WETICE.2006.46>
- Stojanovic, N., & Handschuh, S. (2002). A framework for knowledge management on the semantic web. *The 11th International WWW Conference*, 2–4. Retrieved from <http://ambuehler.ethz.ch/CDstore/www2002/poster/130.pdf>
- Vega-Gorgojo, G., Bote-Lorenzo, M. L., Asensio-Pérez, J. I., Gómez-Sánchez, E., Dimitriadis, Y. a., & Jorrín-Abellán, I. M. (2010). Semantic search of tools for collaborative learning with the OntoSearch system. *Computers & Education*, 54(4), 835–848. <http://doi.org/10.1016/j.compedu.2009.09.012>

Assessing Academics' Knowledge Sharing Intention in Institutions of Higher Learning

Muhammad Ashraf Bin Fauri @ Fauzi¹, Christine Nya-Ling Tan¹, and Ramayah Thurasamy²

¹ Multimedia University, ashrafauzi@gmail.com, nltan@mmu.edu.my

² Universiti Sains Malaysia, Malaysia, ramayah@usm.my

ABSTRACT

Knowledge sharing (KS) in Institutions of Higher Learning (IHL) is a noble culture and should be fostered. IHL is the best platform for knowledge to be disseminated among academics and students. This research adapts the Theory of Planned Behavior (TPB) to determine academics' KS intention in Malaysian IHL. Partial least square SEM is used for analysis. Respondents consist of 45 academics acquired from 399 surveys. Results show that only social network is a significant factor in academics' attitude towards KS intention, while commitment and trust are not. Management support, social media towards subjective norm, and PBC are significant factors for KS intention. Subsequently, attitude and PBC are significant determinants of intention to share and subjective norm is not significant. The findings of this study enable IHL's management to identify the factors to focus on when addressing the issues pertaining to hiring academics.

Keywords: Knowledge sharing, institution of higher learning, PLS-SEM, academics

VII INTRODUCTION

Knowledge management (KM) has gained much attention from various bodies and researchers alike (Donate & Pablo, 2014). This is due to its importance in the creation, acquisition, dissemination and leveraging of available knowledge in an institution for achieving competitive edge and acquiring the intended objectives of the institution (Nicolas, 2004; Suhaimie et al. 2006).

In KM, KS could be the most important element, due to its application which makes it a valuable asset (Yu et al. 2010). In IHL, academics are the personnel who are responsible in disseminating and distributing knowledge to students and other academics. The nature in IHL is intensive in knowledge by creation in research and dissemination in publication (Fullwood et al. 2013). Teaching and performing other obligations such as research are the core duties of academics. When researchers have managed to produce significant outcomes from their study, some are reluctant to share it with other academics. Hence, this study is to determine the academics' KS intention based on the individual (i.e. commitment, social

network and trust), organizational (i.e. management support) and technological factors (i.e. social media) as the determinants for academics' KS intention.

II LITERATURE REVIEW

A. Background

This study adapts the Theory of Planned Behavior (TPB) and Social Capital Theory. TPB serves as the basis to understand academics' behavior in sharing knowledge (Roberto et al. 2014). Ajzen (1991) proposed TPB based on the explanation that human behaviors are determined by such factors which are specific in a definite context.

TPB and TRA stated that academics' intention is shaped by the attitudes and subjective norms. Attitude refers to the individual traits which conform to their specific characteristics. Subjective norm is the belief of what others might think of an individual behavior. TPB has an additional factor which is perceived behavioral control, defined as the ability of individuals to perform a behavior. It is believed that the greater the PBC, the greater the individual's intention to perform the behavior.

The second theory adapted in this study is Social Capital Theory. The theory is efficient in explaining the well-being of individuals and groups (Bassani, 2007). This theory basically explains the social interaction in a group of people, where in this study group, academics share their knowledge with one another. The relations include trust, loyalty, self-esteem and security. This study will adapt the two dimensions of social capital which are trust and social network among the academics in sharing the knowledge. The importance of these two dimensions among the academics is imperative, in order for the academic sector of the country to achieve common goals in life (Putnam, 1995).

B. Hypothesis Development

Commitment. Every organization, including IHL, requires the commitment of their employees for the well-being of overall management. Individuals who possess substantial commitment to their jobs will result in the IHL's ability to challenge and gain advantage over other competitors (Meyer & Parfyonova, 2010). Attitude depends on how much an individual is willing to commit, where the issue of commitment is given attention in the workplace. KS

can be realized when each and every one of the academics is willingly committed in disseminating knowledge in IHL. Commitment affects an employees physical appearance in organizations where work effort, absenteeism and job turnover are directly associated with it (Joiner & Bakalis, 2006). It is therefore hypothesized that:

H1: Commitment has a positive effect on academics' attitudes toward knowledge sharing

Social network. Chow and Chan (2008) found that social network have significant effect on employees intention to share knowledge. As a norm, those who socialize more with other people tend to exchange more ideas and activities. Relationship among academics is one of the predictors for job satisfaction thus positively affecting sharing activities (Lacy & Sheehan, 1997).

The networking among members in IHL will positively affect the attitude and subjective norm of academics towards KS. It is understandable that when the relationship between two people is good, they will feel more comfortable to share their knowledge and this will create an emotional bond among them. This is a community of practice where experts meet and share.

H2: Social networks have a positive effect on academics' knowledge sharing

Trust. Trust has been the most researched dimension in KS (Wang & Noe, 2010). Having trust among academics would enable the motivation to work as a team to achieve common goals and vision. Healthy relationship among academics can be fostered with trust. Commitment, cooperation and relationship among academics will not be realized with the absence of trust (Jolae et al. 2014). When an individual perceived a matter as private and confidential, he or she would not share it unless there is trust among colleagues. To ensure effectiveness of KS, academics must have trust to avoid jeopardizing their position and status in IHL due to misuse of knowledge they shared. The next hypothesis is presented as:

H3: Trust has a positive effect on academics' intention toward knowledge sharing

Management support. Support from the top management has substantial effect on academics' KS. In the context of KS, management support is the direct participation of management in IHL programs and activities. Academics have to understand the KS practices and the activities to ensure voluntary participation (Kang et al. 2008). It is important to get academics to understand that the management supports their actions for KS, as this will encourage and convince academics to share their knowledge and

expertise (Tan & Md. Noor, 2013). Hence, hypothesis 4 is as follows:

H4: Management support has a positive effect on academics' subjective norm towards knowledge sharing

Social media. Academics must keep up with the current technology available in the world, especially social media. KS in the current setting would be better realized with the utilization of social media. Social media can ensure that information and knowledge can be disseminated effortlessly (Osatuyi, 2013). The communication and networking among academics inside and outside the university as well as with students can be upgraded by using social media. Academics must find ways and learn how to adapt with the recent tools and technology to ensure effective KS activities. Therefore, the next hypothesis is presented as:

H5: Social media use has a positive effect on academics' perceived behavioral control toward knowledge sharing

Attitude toward KS. Attitude is known as the degree of evaluation of an individual favor towards a behavior (Ajzen, 1991). Attitude has established as an important determinant of organizational behavior intention. Academics having a favorable attitude towards sharing would be freely sharing their knowledge with other colleagues. The next hypothesis is posited as:

H6: The extent of favorable attitude towards knowledge sharing has a positive effect on academics' intention to share knowledge

Subjective norm. Subjective norm plays an important role in academics intention to share. It is the perception of other people such as colleagues and top management to the academics whether they should share their knowledge or not. It depends on the normative belief, which is the belief of what others might think of their sharing behavior (Lai, Chen, & Chang, 2014). The social subjective norm will induce and provide greater tendency to share (Goh & Sandhu, 2013). The following hypothesis is derived:

H7: The extent of favorable subjective norm toward knowledge sharing has a positive effect on academics' intention to share knowledge

Perceived behavioral control. Based on TPB, intention depends on effort needed to perform the behavior, either it is difficult or not (Ajzen & Madden, 1986). When the KS activities are deemed to be low in effort, academics would see it as an effortless, thus creating more chances for it to happen. Manstead and van Eekelen (1998) have

proved in their study that PBC is a strong factor for behavior. It is therefore hypothesized that:

H8: The level of perceived behavioral control has a positive effect on academics' intention to share knowledge

VIII METHODOLOGY

A. Sampling And Data Collection

This study uses quota sampling method to three subgroups of professors, associate professors and senior lecturers. Portion of quota was divided equally among the three subgroup of (i.e. professor, associate professor, senior lecturers) to 30:40:40. All of the respondents are from public IHL.

B. Measurement

Items used in this study are adapted from previously validated study. Commitment is adapted from Allen and Meyer (1990), social network is from Kim and Lee (2006), trust is from Mcallister (1995), Management support from Sveiby and Simons (2002), social media is from Thong et al. (2002), attitude, subjective norm and intention comes from Bock et al. (2005) while perceived behavioral control is adapted from Wu and Chen (2005).

All items are measured using 7 point likert scale, ranging from 1=strongly disagree to 7=strongly agree. 7 point scale is used in this study due to its accuracy in measuring the respondents true evaluation (Finstad, 2010). According to Cox (1980), 7 point scale is the most suitable for an electronically-distributed survey, which is the methodology of this study. All respondents answered through email which was sent through a period of one month. Furthermore, 7 point scale would cover all necessary information on theory and metric approaches in acquiring the item optimal response.

IX RESULT AND DATA ANALYSIS

A. Analysis Method

This study uses partial least square structural equation modeling PLS-SEM. Smart PLS Version 2.0. PLSEM has several advantages compared to other software. (1) it automatically performs variable selection (2) diverse in its tasks such as classification, transcription factors modeling and survival analysis (3) statistically efficient and (4) fast computational process (Boulesteix & Strimmer 2006)

B. Descriptive Statistics

Descriptive statistic shows that 45 respondents are from the post of senior lecturer, associate professor and professor. In terms of gender, it is evenly distributed with 22 male and 23 female academics. Malay academics make up the highest percentage of

75.6 % with Chinese, Indian and others at 8.9 %, 4.4 % and 11.1% respectively. All of the respondents have at least PhD qualification except for one with Masters degree. The experience of working in academia range from 1-5 years with 5 respondents until 26 years and above with 11.1%.

C. Measurement Model

The measurement model is the first part of PLS-SEM. It elaborates the measurement of the latent variables or the construct that is applied. Measurement model addressed the items reliability and validity, involving each of the construct in the model. The model would facilitate researchers to investigate the validities of the convergent and discriminant of the items and construct respectively (Chin, 2010).

The convergent validity of all the items indicates that they are loaded highly on their construct indicating the convergent validity. The AVE and composite reliability (CR) are the indication of reliability. The value must exceed the threshold value of 0.50 and 0.70 respectively (Chin, 2010; Fornell & Larcker, 1981; Hair et al. 2014). The value obtained as shown in table 2, the AVE range from 0.6083 to 0.8281 and the CR range from 0.8602 to 0.96 which can be said that all the items level of reliability is met.

For discriminant validity, using Fornell and Larcker (1981) criterion, it is found that all items load on the assigned constructs compared with other construct as indicated by the square root of the AVE (Gefen, et al, 2000). This value is shown diagonally in table 1 where the square root of the AVE is higher than other correlation values of other variables indicating satisfactory discriminant validity of this study.

Table 1. Discriminant Validity

	AT	CO	IN	MS	PC	SM	SN	SU	TR
AT	0.874								
CO	0.468	0.843							
IN	0.638	0.341	0.881						
MS	0.349	0.823	0.398	0.884					
PC	0.572	0.454	0.837	0.485	0.910				
SM	0.469	0.359	0.449	0.326	0.627	0.830			
SN	0.572	0.712	0.36	0.559	0.502	0.542	0.779		
SU	0.666	0.426	0.645	0.514	0.622	0.294	0.398	0.781	
TR	0.399	0.670	0.370	0.537	0.489	0.38	0.692	0.254	0.872

AT=attitude, CO=commitment, IN=intention, MS=management support, PB=perceived behavioral control, SM=social media, SN= Social network, TR= Trust

D. Structural Model

The second stage is PLSSEM analysis, which is done by checking its structural model. Bootstrapping procedure with 5000 samples was tested to determine the path coefficient and hypothesis. Figure 2 depicts the structural model of the study.

Results show that attitude and perceived behavior control (H6 and H8) are significantly associated with knowledge sharing intention, while subjective norm (H7) does not. Furthermore, regarding determinants of attitude, only social network (H2) have found to be statistically significant, and commitment (H1) and trust (H3) does not. Management support (H4) and social media use (H5) on the other hand are found to be significant.

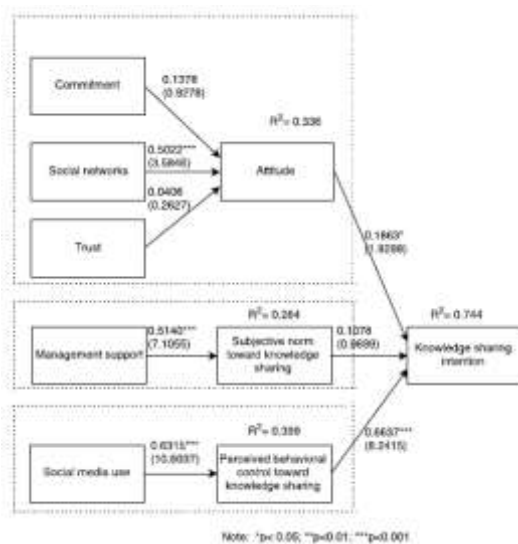

Figure 2. Structural Model

X DISCUSSION

This study is meant to examine the factors which might influence academics KS intention in IHL. It is found that among the three predictor of academics intention to share knowledge, only attitude and perceived behavioral control have significant effects, but not on subjective norms. Meanwhile, among the three determinants of attitude toward KS, only social network has a vital impact, but commitment and trust do not. Even though subjective norm does not significantly affect intention, management support has significant effects. Social media as predicted has significant effect on perceived behavioral control.

Determinants of attitudes towards KS intention have found that only social network had significant impact on KS intention, while commitment and trust does not significantly affect KS intention. This can be explained by the fact that academics do have numerous social networks inside and outside IHL. The more connections they made, the more opportunities to be involved in areas they are experts

in and specific consultation project under academics in the same area of knowledge. This is supported by studies from Jolae et al. (2014) which found that social networks had significant impact on intention. Commitment had no significant impact because this study is based on public IHL, where most public IHL does not have rigorous requirement for academics to fulfill certain requirements compared to private IHL, which include sharing knowledge. Trust also had no significant effect on academics attitude. This is supported by studies from Jolae et al. (2014), Kim & Ju, (2008) and Chin et al. (2014). Academics tend to be individualistic in nature and do not mingle among themselves which resulted in trust being not significant.

Academics' attitude would seem to be one of the most contributors to KS initiatives with path coefficient of 0.1863. This comes from academics individual factor which the authority has to keep concerned. Academics which have positive attitude would have more tendencies to share knowledge. The finding is consistent with previous studies that found attitude as significant factor for KS intention (Akhavan et al. 2015; Jolae et al., 2014; Ramayah et al. 2013).

Social media use among academics has shown to significantly affect PBC, acquiring among the highest path coefficient. Previous studies support the significant effect of social media on academics intention towards KS (Bhagwatwar et al. 2013). It can be deduced that academics do follow the trends in the current changes in social media and technology advancement. This is crucial because social media is the current up-to-date tool for academics to share what they know and also gain new knowledge from other experts worldwide that corresponds to their field of knowledge

Perceived behavior control has the strongest influence toward KS intention with $\beta = 0.6637$. Since academics have control over their behavior, it is within expectation that PBC would significantly affect academics intention. Academics are intellectual group of individuals where their locus of control are gripped with abilities and skill where qualms of sharing knowledge would not be an issue.

Management support also as expected does give significant result on academics' intention. The result shows that perception received from top management by encouraging KS to academics has positively influence academics to willingly share knowledge. This is supported by previous studies proving that management has significant effect on knowledge sharing intention (Lin, 2007).

Surprisingly, subjective norm was found to be insignificant toward KS intention in this study. It can

be inferred that subjective norm was not an important factor in determining academics intention to share. Impression of academics on management support does not shape academics intention towards KS. It may possibly be because of the nature of academics profession where they seldom meet with the management of IHL which includes vice chancellor, dean and also head of department.

A. Theoretical Implications

On a theoretical note, this study has several implications and inferences. Firstly, this study proposed an integrative model consisting of social psychological factor of individual academics (commitment, social network and trust), organizational factor of management support and technological factor of social media use in the context of Malaysian IHL. It is found that PBC has the most significant impact on academics intention to share knowledge. The ability to control and the perceiving of oneself to be able to withhold to a certain behavior impacts directly on academics' intention. This is the self-belief that builds up by the system that corresponds to their use of social media. Academics that are able to use social media would be more inclined to share compared to those who are not.

This study integrates TPB and SCT to determine academics' KS intention in the context of public IHL in Malaysia. This study has linked the two theories to relate between the exogenous and endogenous variables which have contributed to the current body of knowledge.

B. Practical Implications

This study suggests several practical implications especially to the IHL top management. Suggestions from the results of this study are to establish a platform to identify which of the three factors of individual, organization and technological that has significant effect KS intention among academics in IHL. Hiring new academics can be costly to IHL where the government has to spend millions of taxpayers' money on experts in academia. Therefore, in some developing countries, contract teachers are hired to fill in the vacant position left by the permanent staff (Chudgar et al. 2014). If these academics are hired and are reluctant to share knowledge, the monetary amount spent is wasted.

Secondly, practical implications from this study are the relationship among academics attitude towards KS. Taking the result of this study, social network was found to be the most significant factor for academics to share. This can be taken into serious consideration by top management into how to manage academics social networking as a means to promote and enhance KS in IHL.

The findings also suggest that management support plays an important role in influencing academics intention to share. Top management has to fill in the boots of academics, the challenges and plight of fulfilling the annual appraisal requirement, especially in research IHL. Management also has to find ways and solutions to encourage academics on the enjoyment and the practical benefits when they share their knowledge. This can be done by setting up KS rubrics as an annual performance index. This has not been done in Malaysian IHL context, based on the knowledge of the authors. Management should also be open to criticism, and accept the shortage of the system in the education system.

XI CONCLUSION

This study has managed to determine the factors for academics KS intention. TPB and SCT are integrated in this study to contribute to the body of knowledge. Academics' KS intention are dependent on several factors of individual (commitment, social network and trust), organizational (management support) and technological factor (social media use). PLS-SEM was the method used to analyze the research hypothesis in this study. The results show that for attitude of academics, only social network is significant, while commitment and trust are not. Management support and social media towards subjective norm and PBC respectively are significant factor for intention to share. Subsequently, attitude and PBC are significant determinants of intention to share and surprisingly subjective norm is not significant. This study is done on public IHL only and has a low sample size of 45 respondents. This study low sample size is adequate, due to its preliminary nature of pilot study, which according to Hertzog (2008), a general guidelines that a pilot study should at least obtain 10% of the sample for a full study.

ACKNOWLEDGMENT

The author would like to thank the Ministry of Education (MOE) for funding this research this research under the Fundamental Research Grant Scheme (FRGS).

REFERENCES

- Ajzen, I. (1991). The Theory of Planned Behavior. *Organizational Behavior and Human Decision Processes*, 50, 179–211.
- Ajzen, I., & Madden, T. J. (1986). Prediction of goal-directed behavior-attitudes, intentions and PBC.pdf. *Journal of Experimental Social Psychology*, 22, 453–474.
- Akhavan, P., Hosseini, S. M., Abbasi, M., & Manteghi, M. (2015). Knowledge-sharing determinants, behaviors, and innovative work behaviors. *Aslib Journal of Information Management*, 67(5), 562–591.
- Allen, N. J., & Meyer, J. P. (1990). The measurement and antecedents of affective, continuance and normative commitment to the organization. *Journal of Occupational Psychology*, 63, 1–18.

- Bagozzi, R. P., Yi, Y., & Phillips, L. W. (1991). Assessing Construct Validity in Organizational Research. *Administrative Science Quarterly*, 36(3), 421–458.
- Bassani, C. (2007). Five Dimensions of Social Capital Theory as they Pertain to Youth Studies. *Journal of Youth Studies*, 10(October 2014), 17–34.
- Bhagwatwar, A., Hara, N., & Ynalvez, M. A. (2013). Out of Asia: Understanding the nexus between technology usage and research productivity in Japan, Singapore, and Taiwan. *International Journal of Information Management*, 33(6), 963–970.
- Bock, G.-W., Zmud, R. W., Kim, Y., & Lee, J.-N. (2005). Behavioral intention formation in knowledge sharing: Examining the roles of extrinsic motivators, social-psychological forces, and organizational climate. *MIS Quarterly*, 29(1), 87–111.
- Boulesteix, a.-L., & Strimmer, K. (2006). Partial least squares: a versatile tool for the analysis of high-dimensional genomic data. *Briefings in Bioinformatics*, 8(1), 32–44.
- Chin, W. C., Yee, Y. Y., & Geok, C. G. (2014). Knowledge sharing of academic staff. *Library Review*, 63(3), 203–223.
- Chin, W. W. (2010). *How to Write Up and Report PLS Analyses: Handbook of Partial Least Squares*. Springer Handbooks of Computational Statistics.
- Chow, W. S., & Chan, L. S. (2008). Information & Management Social network, social trust and shared goals in organizational knowledge sharing. *Information and Management*, 45, 458–465.
- Chudgar, A., Chandra, M., & Razaque, A. (2014). Alternative forms of teacher hiring in developing countries and its implications: A review of literature. *Teaching and Teacher Education*, 37(2014), 150–161.
- Cox, E. P. (1980). The Optimal Number of Response Alternatives for a Scale: A Review. *Journal of Manufacturing ...*, 17(4), 407–422.
- Donate, M. J., & Pablo, J. D. S. de. (2014). The role of knowledge-oriented leadership in knowledge management practices and innovation. *Journal of Business Research*, 68(2), 360–370.
- Finstad, K. (2010). Response Interpolation and Scale Sensitivity: Evidence Against 5-Point Scales. *Journal of Usability Studies*, 5(3), 104–110.
- Fornell, C., Larcker, D. F. (1981). Evaluating structural equation models with unobservable variables and measurement error. *Journal of Marketing Research*, 18, 39–50.
- Fullwood, R., Rowley, J., & Delbridge, R. (2013). Knowledge sharing amongst academics in UK universities. *Journal of Knowledge Management*, 17(1), 123–136.
- Gefen, D., Straub, D. W., & Boudreau, M.-C. (2000). Structural Equation Modeling and Regression: Guidelines for Research Practice. *Communications of AIS*, 4(August), 7. doi:10.1.1.25.781
- Goh, S. K., & Sandhu, M. S. (2013). Knowledge Sharing Among Malaysian Academics: Influence of Affective Commitment and Trust. *Electronic Journal of Knowledge Management*, 11(1), 38–48.
- Hair Jr, J., Sarstedt, M., Hopkins, L., & G. Kuppelwieser, V. (2014). Partial least squares structural equation modeling (PLS-SEM). *European Business Review*, 26, 106–121.
- Joiner, T. a., & Bakalis, S. (2006). The antecedents of organizational commitment: the case of Australian casual academics. *International Journal of Educational Management*, 20, 439–452.
- Jolaei, A., Md Nor, K., Khani, N., & Md Yusoff, R. (2014). Factors affecting knowledge sharing intention among academic staff. *International Journal of Educational Management*, 28(4), 413–431.
- Kang, Y.-J., Kim, S.-E., & Chang, G.-W. (2008). The Impact of Knowledge Sharing on Work Performance: An Empirical Analysis of the Public Employees' Perceptions in South Korea. *International Journal of Public Administration*, 31(May 2015), 1548–1568.
- Kim, S., & Ju, B. (2008). An analysis of faculty perceptions: Attitudes toward knowledge sharing and collaboration in an academic institution. *Library & Information Science Research*, 30(4), 282–290. doi:10.1016/j.lisr.2008.04.003
- Lacy, J., & Sheehan, A. (1997). Job satisfaction among academic staff: An international perspective. *Higher Education*, 34, 305–322.
- Lai, H. M., Chen, C.-P., & Chang, Y.-F. (2014). Determinants of knowledge seeking in professional virtual communities. *Behaviour & Information Technology*, 33(January 2015), 522–535.
- Lin, H.-F. H.-F. (2007). Knowledge sharing and firm innovation capability: an empirical study. *International Journal of Manpower*, 28(3), 315–332.
- Malone, D. (2002). Knowledge management A model for organizational learning. *International Journal of Accounting Information Systems*, 3, 111–123.
- Manstead, A. S. R., & van Eekelen, S. a. M. (1998). Distinguishing between perceived behavioral control and self-efficacy in the domain of academic achievement intentions and behaviors. *Journal of Applied Social Psychology*, 28(15), 1375–1392.
- McAllister, D. J. (1995). Affect- and cognition-based trust as foundations for interpersonal cooperation in organizations. *Academy of Management Executive*, 38(1), 24–59.
- Meyer, J. P., & Parfyonova, N. M. (2010). Normative commitment in the workplace: A theoretical analysis and re-conceptualization. *Human Resource Management Review*, 20(4), 283–294.
- Nicolas, R. (2004). Knowledge management impacts on decision making process. *Journal of Knowledge Management*, 8, 20–31.
- Osatuyi, B. (2013). Information sharing on social media sites. *Computers in Human Behavior*, 29(6), 2622–2631.
- Putnam, R. (1995). This journal is published by the American Political Science Association. All rights reserved. *PS: Political Science & Politics*, (December).
- Ramayah, T., Yeap, J. a. L., & Ignatius, J. (2013). An Empirical Inquiry on Knowledge Sharing Among Academics in Higher Learning Institutions. *Minerva*, 51(2), 131–154.
- Roberto, A. J., Shafer, M. S., & Marmo, J. (2014). Predicting substance-abuse treatment providers' communication with clients about medication assisted treatment: A test of the theories of reasoned action and planned behavior. *Journal of Substance Abuse Treatment*, 47(5), 307–313.
- Suhaimee, S., Zaki, A., Bakar, A., & Alias, R. A. (2006). Knowledge Sharing Culture in Malaysian Public Institution of Higher Education: An Overview, (September 2004), 354–359.
- Sveiby, K., & Simons, R. (2002). Collaborative climate and effectiveness of knowledge work – an empirical study. *Journal of Knowledge Management*, 6(5), 420–433.
- Tan, C. N.-L., & Md. Noor, S. (2013). Knowledge management enablers, knowledge sharing and research collaboration: a study of knowledge management at research universities in Malaysia. *Asian Journal of Technology Innovation*, 21(January 2015), 251–276.
- Thong, J. Y. L., Hong, W., & Tam, K. (2002). Understanding user acceptance of digital libraries: what are the roles of interface characteristics, organizational context, and individual differences? *International Journal Human Computer Studies*, 57, 215–242.
- Wang, S., & Noe, R. a. (2010). Knowledge sharing: A review and directions for future research. *Human Resource Management Review*, 20(2), 115–131.
- Wu, I.-L., & Chen, J.-L. (2005). An extension of Trust and TAM model with TPB in the initial adoption of on-line tax: An empirical study. *International Journal of Human-Computer Studies*, 62, 784–808.
- Yu, T. K., Lu, L. C., & Liu, T. F. (2010). Exploring factors that influence knowledge sharing behavior via weblogs. *Computers in Human Behavior*, 26(1), 32–41.

Stock Split Analysis on Price and Trading Volume in Indonesian Stock Exchange

Ibnu Khajar

Sultan Agung Islamic University (UNISSULA), Indonesia, didijon58@yahoo.co.id

ABSTRACT

Stock split is not a new issue in Indonesia Stock effect. There are many controversies are found in the research results about the impact of the corporation action on the company value and stock trading volume. This study aims to analyze the impact of stock split on stock price and stock trading volume. Four companies incorporated in LQ-45 of Indonesia Stock Exchange become the sample of this research. One sample t-test and paired sample t-test are used as the statistical analysis method. The result shows that corporation action of stock split positively impact on stock price, but negatively impact on stock trading volume. The contribution of this research for knowledge management is to add data base and reference in managerial field which then can be used to make investment decisions, especially in long-term financial assets.

Keywords: Stock Split, Stock Reverse, One Sample T-Test, Paired Sample T-Test.

I INTRODUCTION

Investors consider stock split as signal of the improvement of company performance, while stock reverse is considered as a negative signal of the decrement of company performance. The data of Indonesia Stock Exchange shows that from 66 companies performing corporate action, only 18 % of them perform stock reverse, and the rest perform stock split.

The investor belief that stock split is a positive signal is not fully right, as some research findings support the statement and some of them do not. Mishra (2006), Bechmann and Raaballe (2007), and Cakraborty (2012) state that the policy of stock split is merely to polish and does not impact on the stockholders' wealth. The number of stocks may increase but with lower price. However, how the stock price in the future period after the action will be interesting to study. If the stock price in the future period after the action impacts on the stock price improvement, the action will bring benefit to the stockholders because their wealth will be also increased. Yet, if the stock price decreases, the action will pull down their wealth and result lost.

Kurniawati (2003) conducts a research about stock split and notes that there is abnormality on the announcement of stock split which shows that the stock price decreases after the action. This is different from the study of Waweru and Mwendwa (2012) as it notes that 5 of 10 companies which perform stock split in Nairobi Stock Exchange (NSE) get their stock price increases and 5 of them get the price decreases. The study conducted by Metha, Yadav and Jain

(2011) shows that the majority of respondents do not believe that stock split bring positive signal to the company future prospect. Pooja (2013) states that companies performing stock split in India Stock Exchange do not impact the stock price. Ford, H. Nguyen and T. Nguyen (2012) also emphasize that after stock split, the stock price decreases.

Besides, based on the liquidity after stock split, many study results show significant improvement Mishra (2006), Cakraborty (2012), Kurniawati (2003), Waweru and Mwendwa (2012), Metha, Yadav and Jain (2011), Pooja (2013) as well as Ford, H. Nguyen, and T. Nguyen (2012). Based on the research gap, it will be urgent and interesting to study on how the corporation action of stock split in Indonesia Stock Exchange impact on the stock price and stock trading volume.

Stock split is a form of corporate action performed by go-public companies in Indonesia and many other countries in the world. This research proposes to analyze the condition of stock price and stock trading volume before and after stock split.

II LITERATURE REVIEW

A. Stock Split and Stock Reverse

There are two types of stock split, such as forward split and reverse split (Yan dan Junbo, 2012). Bechmann and Raaballe (2007) explain that forward split is splitting one piece of old stock into a number of new stocks by decreasing the stock nominal value, and the total of stock capital does not change. Jones (2007) states that stock split involve a bigger amount of stocks based on the proportion of outstanding stocks. The existence of stock split makes the value of book and nominal change. For example, each value will be cut if the split ratio 1:2. Hwang et al (2012) describes reverse split as unusual event where company substitutes some stocks with one stock without any changes in the total capitulation of stock capital.

There are some reasons why company performs stock split. As forward split break down one stock into some stocks, it results more stocks than before, but with cheaper price for each. Besides, reverse split merge or combine some stocks into one, hence the price per price increases and the outstanding stock decreases.

B. Stock Price

Stock is a proof of ownership of a company. Those who own stock in a go-public company, whether if it is acquired through stock buying in Stock Exchange or through other way, for example through bonus acquired from the company in a form of stock. Thus, the stock holder roles as stockholder based on the number of stock

that he/she has. The more number of stocks a person has, the bigger percentage of ownership of the company.

Stock has some types of prices, such as nominal price and market price. Go-public companies have nominal price and market price both in primary and secondary markets. Unless for stock price in secondary market, the nominal price and primary market price are static. In the development, nominal price will also change if the company performs corporation action like stock split or stock reverse.

In many financial literatures, it is mentioned that a company is built in order to bring benefit and increase the owners' wealth. If a company is operating with benefit, the period of company will cumulatively longer, and the owners' wealth will be bigger. The amount of the rising wealth can be count from the amount of benefit acquired both in cash and other kinds of assets. Special for go-public companies, the amount of the owners' wealth is analogues to the amount of the stockholders' wealth is relatively countable because go-public companies have stock market price (secondary market). Thus, the wealth can simply counted based on the amount of stocks multiplied to the price per stock in the market. The wealth can increase if the company acquires more benefit as the stock price will also increase.

There are two factors why stock price can increase and decrease, such as internal factor (micro) and external factor (macro). The internal factor is reflected from the company condition, such as how the sales and the sales growth are, how the efficiency of the company operational costs is, and how the level of company profit is. The external factor usually cannot be controlled by the company, including bank interest rate, fuel price, electricity, and social politic and law condition. The company stock price will fluctuate if both internal and external factors experience changes.

C. Stock Trading Volume

Stock trading volume can be one of indicators of the market condition whether it is crowded or not. The bigger trading volume, the more crowded the market will be, which means the amount of stock transacted is bigger. Stock trading volume is well-noted in the amount of stocks or the Rupiah value of the stock. The more investors who sell and buy stocks, the higher value of stock trading will be.

There are some ratios used in measuring stock trading volume, such as TVA (Trade Volume Activity), which is the ratio between the number of stocks traded and the number of outstanding stocks. The higher value of TVA, the more stock volume traded will be. Joshipura (2009) uses volume ratio in his research, where if the value is one (1) or almost one (1), the stock trading volume will be considered as normal. Then, if the ration value is less than one (1), the stock trading volume will be considered as abnormal.

H2: There is significant difference of trading volume activity before and after the corporation action of stock split is accepted.

D. Signaling Hypothesis

The information in the management and investors are different and this is reasonable because the internal party directly run the company and face fundamental situation in the company every day. Thus, if the company performs corporation action of stock split, it can be considered as a signal of a better performance of the company or at least it has potential to improve its future performance. If the company stock price is already expensive, even the performance is improving, the stock price cannot significantly pulled up. This possibly happens because the investors cannot buy the stock as the price is too expensive, especially for investors in low-to-medium level. However, lower price of company stock can be benefit because there will be more investors who are able to buy the stock, hence the stock trading volume will increase.

According to signaling hypothesis, managers in a company can use the stock distribution as positive signal of optimistic expectation for investors in the capital market. As internal party, managers usually have estimation dealing with better company prospect than the external party. Thus, the managers can inform their internal information to investors through financial decisions (Powell, Phillips & Baker, 1995).

H1: Stock split positively impact on Stock Price

III RESEARCH METHOD

This research performs event study method to know the impact of an event on security price. This research analyzes the impact of stock split on the stock price and trading volume. The market reaction can be measured through the return or abnormal return around the stock split announcement.

In general, the research method follows the following procedures: (1) collecting sample from company with similar issue, (2) deciding the right day or the *cum-date* (the final date of stock trading with old nominal value of the announcement and is assigned as Day-0), (3) deciding the research period or *event window* as long as 11 days; 5 days before the announcement of corporate action and 5 days after the *cum-date*, (4) calculating the daily stock return for every sample company, (5) calculating the abnormal return (mean adjusted model) of every period in window period for all sample companies from the return acquired, (6) statistically assessing whether the abnormal return is significant or not.

A. Population and Sample

The population of this research is all companies listed in Jakarta Stock Exchange in Index LQ-45 and has performed stock split from 2010 to 2016. This research uses sample in the period of 2010-2016 because in 2008 there is global financial crisis. It is assumed that 2 years after the crisis, IDX becomes normal again. This research uses purposive sampling to select the sample with the following criteria:

1. The date of stock split announcement and *cum-date* is provided.
2. The company does not perform other company actions except stock split on the *event window* around the announcement date.
3. The stock price data around the announcement can be acquired
4. The data of stock trading volume around the announcement date is provided

From the above criteria, there are 4 companies fulfilling all criteria, such as PT Telkom (TLKM), PT Kalbe Farma (KLBF), PT Astra Internasional Indonesia (ASII) dan PT Bank Rakyat Indonesia (BBRI).

This research use secondary data, as the lists of companies which perform stock split around the announcement date or *cum-date* from Harian Bisnis Indonesia (Indonesia Business Daily) and PT Kustodion Sentral Efek Indonesia (PT KSEI), while the daily stock price is acquired from Yahoo Finance.

B. Variable Operational Definition

To know the impact of right issue announcement on the stockholders' wealth, the following variables are used:

1. The date when *cum-date* is designated as period zero ($t=0$) in the window period, that is the final date of the stock trading with old nominal value.
2. 5 days after the event, that is 5 days after the period of $t=0$ (*cum-date*).
3. 5 days before the event, that is 5 days before the announcement date.
4. Stock return is the closing price on certain days, reduced by the previous day closing price, divided to the previous day closing price.
5. Abnormal return is the difference between the real return in the window period, reduced by the expected return (mean-adjusted model).

C. Statistical Analysis

In this research, the data analysis model uses *paired sample t-test* and *one sample t-test* to know the impact of stock split on stock price and stock trading volume and the existence of trade volume activity and abnormal return before and after the stock split.

IV RESULTS AND DISCUSSION

A. Variable Description

The main variables in this research are stock price and stock trading volume before and after the corporate action of stock split. The impact of stock split can be seen from the change of stock price and trading volume in the company. The indicator of change in stock price is from whether or not the abnormal return exists and the change in stock trading volume can be seen from whether or not the Trade Volume Activity (TVA) exists.

A.1. Abnormal return

Abnormal Return is surplus of return above or below the expected return. This research identifies it in window

period (i.e. 5 days before the corporation action announcement and 5 days after *cum-date*). The data used to compute abnormal return is taken from Yahoo Finance (2016) and The Indonesian Stock Exchange (IDX-2016). The abnormal return of the sample companies is compiled in Table 1 and Figure 1.

Table 1: Abnormal Return around the Stock Split Announcement

No.	-5	-4	-3	-2	-1	0	1	2	3	4	5
BBRI	-0.016	-0.006	0.028	-0.025	-0.055	0.031	0.040	0.019	0.008	-0.021	-0.011
TLKM	-0.014	0.016	0.003	-0.052	-0.067	-0.053	0.063	0.034	-0.013	-0.024	0.022
KLBF	0.005	-0.001	0.005	0.092	-0.033	0.021	-0.011	0.010	0.020	-0.001	-0.011
ASII	-0.015	-0.012	-0.007	-0.003	-0.001	-0.015	0.057	0.053	-0.022	-0.022	-0.008

Source: analysed data

Based on the data acquired, the abnormal return of every sample changes in every period in the *window period*. This shows that the corporation action of stock split impact on the stock price.

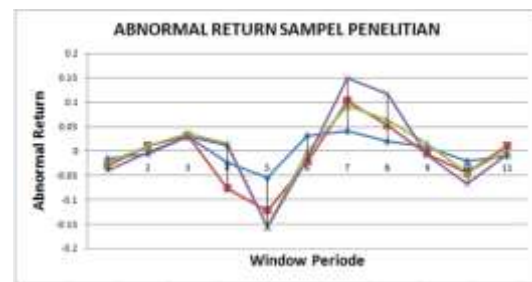

Figure 1: Visual Graphic of Abnormal Return

A.2. Trade Volume Activity (TVA)

Trade Volume Activity is a measurement to see the change in stock trading volume before and after the corporation action of stock split. The data used to compute TVA is taken from Yahoo Finance (2016) and The Indonesian Stock Exchange (IDX-2016). TVA of the sample companies is compiled in Table 2 and Figure 2.

Table 2: Trade Volume Activity (TVA) around the Stock Split Announcement

No.	-5	-4	-3	-2	-1	0	1	2	3	4	5
BBRI	0.001	0.002	0.002	0.002	0.005	0.002	0.001	0.001	0.001	0.001	0.001
TLKM	0.005	0.003	0.003	0.007	0.008	0.006	0.001	0.001	0.001	0.001	0.000
KLBF	0.004	0.004	0.005	0.007	0.011	0.005	0.001	0.001	0.001	0.001	0.001
ASII	0.008	0.008	0.011	0.012	0.013	0.011	0.001	0.001	0.001	0.000	0.001

Source: analysed data

Trade Volume Activity (TVA) of the sample in this research experience change in every period in the *window period* before $t=0$ which means that corporation action of stock split impact on the stock trade volume. Besides, TVA in the period after $t=0$ relatively stable.

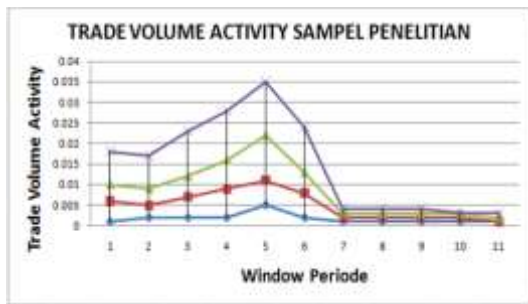

Figure 2: Visual Graphic of Trade Volume Activity (TVA)

B. The impact Stock Split on Stock Price

The impact of stock split on stock price can be seen from the existence of positive or negative abnormal return in the *window period*. Based on the statistical analysis using one sample t-test to analyze the existence of abnormal return in the *window period*, the result is explained as Table 3.

Table 3: Statistical Result of One Sample T-Test

	N	Mean	Std. Deviation	Std. Error Mean
ali	4	-.00209	.016101	.008051
aem	4	-.01704	.010934	.005467
ati	4	-.00153	.019187	.009594
adu	4	.02863	.018764	.009382
asa	4	.03735	.033771	.016885
c1	4	-.00425	.038025	.019012
bsa	4	-.03893	.029010	.014505
bdu	4	.00328	.062601	.031301
bti	4	.00707	.014775	.007388
berm	4	-.00068	.011834	.005917
bli	4	-.00999	.010112	.005056

Source: print-out SPSS

Empirically, Table 3 shows that there are both positive and negative abnormal returns in the window period. For example, on the *cum-date* there is a negative abnormal return 0,425%, and there is also a negative abnormal return 3,89% on one day before stock split announcement. Then finally, on one day after *cum-date* is there a positive abnormal return 3,74%.

Table 4: Testing Result One Sample T-Test

	Test Value = 0						
	t	df	Sig. (2-tailed)	Mean Difference	95% Confidence Interval of the Difference		
					Lower	Upper	
ali	-.258	3	.812	-.002088	-.02771	.02353	
aem	-3.118	3	.053	-.017038	-.03444	.00336	
ati	-.159	3	.884	-.001527	-.03206	.02900	
adu	3.051	3	.055	.028628	-.00123	.05949	
asa	2.212	3	.114	.037350	-.01639	.09109	
c1	-.224	3	.837	-.004252	-.06476	.05625	
bsa	-2.684	3	.075	-.038932	-.08509	.00723	
bdu	.105	3	.923	.003283	-.08633	.10289	
bti	.957	3	.409	.007070	-.01644	.03058	
berm	-.118	3	.915	-.000685	-.01952	.01815	
bli	-1.978	3	.143	-.009993	-.02803	.00810	

Source: print-out SPSS

Based on the testing result using one sample t-test as Table 4, it is known that there are abnormal returns both before the corporation action announcement and after the *cum-date* of corporation action. One day before the announcement, the stock price decreases, shown by the

existence of negative abnormal return 3,89%, and the significance level $7,5\% < \alpha 10\%$. Then, two days after the *cum-date* the stock price increases, proven by the existence of positive abnormal return 2,86% with significance level $5,5\% < \alpha 10\%$. Four days after *cum-date*, the stock price also decreases, known from the existence of negative abnormal return 1,70% with significance level $5,3\% < \alpha 10\%$. Therefore, the statement that there is significant abnormal return in the window period is accepted.

Negative abnormal return found before the announcement indicates that the investors do not know about the corporation action, the investors' decision then is not to include the information about stock split. Their decision is predicted based on general information in the market, from fundamental and technical factors. The corporation action can be considered kept as secret before being announced to public. This is proven by the absence of the positive abnormal return before the period, yet the negative abnormal return exists, and this empiric result fit with Kurniawati (2013).

Different from the market reaction on corporation action (there is positive abnormal return), the stock price significantly increases after the stock split and the investors react positively. There are at least two reasons why stock split can increase the stock price. First, the investors interpret the performance of company which perform corporation action increases, or there is improvement potential of the company performance in the future. Companies with expensive stock price remain perform stock split because even though the performance is good, but the stock price cannot increase. The expensive stock price makes the investors reluctant to buy the stock, even though the company has better performance time to time. This possibly happens because Indonesia has many investors from low-to-middle level, hence to buy expensive stock they have to spend a big amount of money. Thus, the stock price of a company relatively stagnant and it needs to be improved, in this case, by performing stock split.

The second reason is because the cheaper stock price from the investors' perspective. By the implementation of stock split, the investors are initially unable to buy the stock then become able to buy it, so the numbers of investors who are interested in buying the stock get increased. According to the law of supply and demand, if the demand increases, the price will also increase. This is similar with companies performing corporation action, the demand will be predicted to increase which will trigger the improvement of stock price and significant positive abnormal return. Therefore, the hypothesis that stock split positively impact on stock price is accepted and finally also fit with the signaling hypothesis. This empiric result is consistent with Rabroty (2012), but contrary with Fama, Fisher, Jensen, and Roll (1969), Mishra (2006) and Pooja (2013).

C. The Impact Stock Split on Stock Trading Volume

The impact of stock split on stock trading volume can be seen from the existence or the absence of difference on Trade Volume Activity (TVA) before and after the corporation action of stock split. Based on the statistical

analysis using paired sample t-test, the result is compiled as follow:

Table 5: Statistical Result Paired Sample T-Test

		Mean	N	Std. Deviation	Std. Error Mean
Pair 1	After	.00086	25	.000310	.000062
	Before	.00606	25	.003326	.000665

Source: print-out SPSS

Based on the result acquired, it can be interpreted that TVA after the corporation action is decreasing from 0,6% before the corporation action become 0,1% after the corporation action. This means that the number of stock traded after the corporation action is also decreasing. The next analysis is to know whether the decreased stock trading volume is significant or not.

Table 6: Testing Result Paired Sample T-Test

		Pair 1	
		After	Before
Paired Differences	Mean		-.005204
	Std. Deviation		.003444
	Std. Error Mean		.000689
	95% Confidence Interval of the Difference	Lower	Upper
			-.008625
			-.001782
t			-7.554
df			24
Sig. (2-tailed)			.000

Source: print-out SPSS

Based on Table 6, the difference of TVA before and after the corporation action is significant. This is proven by the result of paired sample t-test which shows that the significance level is 0,000 (lower from the significance level of 5%). Thus, the statement that there is significant difference of trading volume activity before and after the corporation action of stock split is accepted.

It is empirically proven that stock trading volume is significantly decreasing after the corporation action of stock split. There is some positive logical thinking from investors which strengthen the first empirical finding that the stock price increases after the corporation action. The investors believe that the company performing corporation action has better performance or at least potential of better performance. Thus, there are many purchasing activity after the action which also indicate the increasing demand that impact on the improvement of stock price. However, the trading activity decreases, so the TVA also decreases in accordance with the second finding. The decreasing trading activity as a result of investors who are reluctant to sell their stocks and aim to hold the stocks in longer period in order to gain more benefit or dividend because they believe that the company performance will get better.

This analysis is also an imperfect variable of TVA, where it only measures the number of trading volume which actually includes stock selling and buying. Thus, if the TVA is decreasing (as happening in this research), it is unobvious whether the stock purchasing or buying is decreasing. The up and down of these two aspects bring substantial implication on the companies performing the action.

The other analysis why the trading volume activity decreases is the analysis period (the *window period*) which is too short (only 11 days; 5 days before and 5 days after the

action). Therefore, many investors have done the purchasing activity and only some of them have done trading activity, so the overall trading volume activity decreases. Thus, stock split negatively impact on stock trading volume. After all this empiric results is contra with the result research before like as Chakrabrotty (2012), Fama, Fisher, Jensen, and Roll (1969), Mishra (2006) and Pooja (2013).

D. The Research Contribution to The Knowledge of Management

Koontz and Wehrich (1990) state that management is process of designing and maintaining environment where individuals are working together in groups, efficiently accomplishing selected aims.

The main aim of business organization is to maximize stockholders' wealth or increase the firm value. There are many ways to achieve that, one of them is by investment in long-term financial assets, for example to buy stock in the capital market. The result of this research can be used as reference or data base to make decision related to investment decisions.

V. CONCLUSION

The information about the corporation action of companies involved in LQ-45 does not leak to public before the announcement which empirically proves that there is no positive abnormal return before the announcement of corporation action of stock split. The stock price increases after the corporation action of stock split, which is empirically proven from the positive and significant abnormal return. The investors believe that the performance of companies which perform stock split is improving or at least the companies have potential to improve their performance. This makes them do trading activity, so the stock price increases. The Trading Volume Activity (TVA) after the corporation action significantly decreases because the purchasing activity increases while the period is too short to know about the trading activity (there are only a few of investors do trading activity). Thus, in order to get comprehensive result, the *window period* needs to be longer (for example, 61 days) so the investors have longer period to do trading activity. This is meant to know further about the impact of corporation action. On the other side, as trading volume activity includes both purchasing and trading activities, the future research should specify on which activity is increasing or decreasing.

The research contribution for knowledge management is as reference or data base for managerial to make investment decision in long-term financial asset in the capital market.

REFERENCE

- Baker, Phillips & Powell (1995). Financial Practice and Education, The Stock Distribution Puzzle: A Synthesis Of The Literature, Spring/Summer.
- Bechmann and Raaballe (2007). *Journal of Business Finance & Accounting*, 34(3) & (4), 574-604, April/May 2007, 0306-686Xdoi: 10.1111/j.1468-5957.2007.02041.x, The Differences Between Stock Splits and Stock Dividends: Evidence on the Retained Earnings Hypothesis, USA.

- Chhavi iVlehta, Surendra S. Yadav, and P.K. Jain (2011). Managerial Motives for Stock Splits; Survey Based Evidence from India. *Journal Of Applied Finance-No. 1*.
- Deborah A. Ford, Hoang H. Nguyen, and Van T. Nguyen (2012). Analyst coverage and market reaction around stock split announcements, *Applied Financial Economics*, 2012, 22, 135–145.
- Fama, Eugene F., Lawrence Fisher, Michael C. Jensen, and Richard Roll (1969). "The Adjustment of Stock Prices to New Information, *International Economic Review* 10:1 (February), 1-21.
- Hwang et al. (2012). *International Atlantic Economic Society*, Do Reverse Stock Splits Benefit Long-term Shareholders?, Springer, DOI 10.1007/s11294-012-9370-3.
- Jones Charles P. (2007). *Investments*, John Wiley & Sons(Asia) Pte. Ltd.
- Kurniawati, Indah. 2003. Analisis Kandungan Informasi Stock Split dan Likuiditas Saham: Studi Empiris pada Non-synchronous Trading. *Jurnal Riset Akuntansi Indonesia*. Vol. 6. No. 3. P. 264-275
- Lakonishok, Josef and Baruch Lev, 1987, "Stock Splits and Stock Dividends: Why, Who, and When," *Journal of Finance* 42:4(September), 913-932.
- Madhumita Chakraborty (2012). The Equity Market around the Ex-Split Date: Evidence from India *Vikalpa* Volume 37 • NO 1 • January – March.
- Mishra (2006). *International Journal of Theoretical and Applied Finance* Vol. 10, No. 2 (2007) 251–271c, World Scientific Publishing Company.
- Mayank, Joshipura (2009). *Indian Journal Of Finance*, Price and liquidity effects of stock split: An Empirical evidence from Indian stock market, Volume 3, Issue 10, October 2009.
- Nelson Maina Waweru and John Mwendwa (2012). Stock Splits And Their Effect On Share Prices: A Study Of Firms Listed On The Nairobi Stock Exchange (NSE), *Academy of Accounting and Financial Studies Journal*, Volume 16, Number 2.
- Pooja (2013). Stock Split Announcement and Liquidity Effect: Evidence from India, *Vilakshan, XIMB Journal Vol.10 (1) ; March*.
- Wehrich and Koontz (1990). *Essentials of Management*, Fifth Edition, McGraw-Hill Publishing Company, Singapore.
- Yan, Junbo (2012). *Journal of Applied Finance*, Stock Split Decisions: A Synthesis of Theory and Evidence, United States

An Improved Searching Method for Retrieving Local Knowledge Information

Wong Poh Lee¹, Mohd Azam Osman¹, Tarmiji Masron², and Abdullah Zawawi Talib¹

¹Universiti Sains Malaysia, Malaysia, wongpohlee@hotmail.com, {azam; azht}@usm.my

²Universiti Malaysia Sarawak, Malaysia, mtarmiji@unimas.my

ABSTRACT

Local knowledge information has been widely available for years. These information mainly resides in the form of paper or media which are mainly stored in archives for researchers. When a user tries to retrieve these information, a thorough search has to be done manually to locate specific search query from a user. A lot of these data are not stored digitally and mostly recorded in unstructured form due to the complexity of the data collection. Besides, the implementation of a search method for locating specific information is difficult due to the unstructured form of the data. In this paper, an improved search method which combines the search by selection and search by keywords methods is proposed for retrieving data which can be applied to both structured and unstructured data. The results of the search can be represented in the form of text and graphical charts. The case study presented in this paper is limited to the local knowledge information collected in several states in Malaysia.

Keywords: information retrieval, local knowledge, structured data.

I INTRODUCTION

Nowadays, having and managing a lot of information, whether they are in structured or unstructured forms is common among the researchers and the general public. These information grow day by day. Some of the information are stored digitally while some of them are stored in a traditional manner that is in the forms of document, video or journal. These information will be more meaningful and useful to the users if they are presented in a proper representation or in a well-organized documentation.

The problem of the existing searching methods is that the search engine is too general which would normally returns a lot of information regardless of whether they are relevant or irrelevant to the users. Furthermore, it complicates the process of retrieving the required information. A good search engine should minimize these problems and provide the best results to the users.

In this paper, a local knowledge repository system consisting of local knowledge information in Malaysia is taken as a case study. This system includes a smartly developed searching method which returns the relevant results to the users' query by combining the search by selection and search by keywords searching methods. The results of the improved searching method will be evaluated by comparing it with the original searching methods based on the number of relevant results.

II BACKGROUND

As data are becoming larger and larger, an optimized search method is required to provide the most relevant information to the users. Therefore, a thorough review has been carried out to identify the current search method which is commonly used in retrieving information from databases.

A. Data in Local Knowledge Systems

Local knowledge information appears in many forms ranging from documents and images to videos. Local knowledge contains useful information which could be used as a reference for research or a guide for future development or advancement. A lot of studies have been carried out on local knowledge in different countries (Benferhat & Garcia, 1996; Duan, Subramanian, & Abdulrahman, 2013). Each of the collected data is managed differently depending on the structure of the data.

As the number of local knowledge data increases, the need for a proper system is required to provide a hub for knowledge sharing and dissemination of information to the users. van Splunter, van Langen, & Brazier (2005) proposed the use of templates to represent the knowledge and to use the web service technology as a technique to communicate with the web. Based on literatures, there are a lot of local knowledge data which focus largely on health and medical records. These data are further digitized to provide knowledge for the health centers such as knowledge on reducing sickness and improving a living lifestyle (Damtew, 2010).

B. Existing Search Methods

There are a lot of existing searching methods that provide the best web contents to the users (Killoran, 2013; Kawano, 2000). Different techniques were proposed to increase the search performance while providing the most accurate results for the users.

Khan, Sangroha, Ahmad, & Rahman (2014) proposed a semantic approach that is carried out by understanding the term instead of comparing the keywords. Tumer, Shah & Bitirim (2009) have investigated the semantic approach performance by comparing both the keyword-based search and the semantic search approach.

Searching methods have become an important factor especially in the medical field (Inthiran, Alhashmi, & Ahmed, 2010). The structure of medical data varies which makes it challenging to provide the most feasible search engine. The job of the search engine is to provide the most relevant results based on user queries. Lovic, Lu, & Zhang (2006) proposed the use of rules in existing search engine. It fixes the flaws of having a lot of irrelevant results while improving the performance of the searching process.

III IMPROVED SEARCHING METHOD

The searching methods deliberated in this paper are search by selection, search by keywords and the proposed improved searching method that combines both search by selection and search by keywords methods. In this paper, we respectively name the methods as follows:

- Searching Method I: Searching by selection based on the given choices.
- Searching Method II: Searching by keywords in which the users are able to enter the keywords of their choice.
- Searching Method III: Searching using a combination of the above-mentioned Searching Method I and Searching Method II

Searching Method I is a pre-defined selection which smartly extracts data from the database for the users to choose. The selection bar will not include choices which do not appear in the database. This is to keep the choices as simple as possible while retaining the most relevant results for the users.

Searching Method II is an advanced algorithm which looks for words residing in the local knowledge information. The words in the context is highlighted with a distinctive colour to denote the existence of the word in the context. The pseudocode of Searching Method II is as follows:

Seaching Method II - Keyword Search

Get keywords

Split keywords if keywords contains more than one word

Search through the context by category to determine whether the keyword exists

Replace keyword with a distinctive color style

Repeat process for the next keyword

Display results in a tabular form separated by category

Searching Method III which is combination of both Searching Method I and Searching Method II limits the search results by considering the choices chosen by the user so that the results would be more specific and relevant to the user's needs.

IV RESULTS AND DISCUSSION

An experiment was carried out to evaluate the practicality of the improved searching methods. For Searching Method I, selections from random choices were carried out to evaluate the accuracy of the results. For Searching Method II, keywords were used by entering random texts of different length. For Searching Method III, choices were selected from the given selection boxes and some keywords were entered at the same time. The final results consist of the number of relevant results over the total results. The accuracy (in percentage) is calculated using the following formula:

$$Accuracy = \frac{Relevant\ Results}{Total\ Results} \times 100$$

Table 1 and Table 2 show the results for Searching Method I and Searching Method II respectively. Searching Method I is suitable for structured data while Searching Method II is suitable for unstructured data. Searching Method I is suitable for structured data because this method can easily match and retrieve data from the structured tables in the database. Searching Method II is suitable for unstructured data is due its capability which allows the search is being done by the entered keywords and match with the content in the database. By introducing Searching Method III (combining both Searching Method I and Searching Method II), the data can be searched simultaneously by considering the parameters from the structured data and, unstructured data. Table 3 shows the result for Searching Method III.

Table 1. Results of Searching Method I

Number of selections	Relevant Results	Total Results	Accuracy
20	153	153	100%

Table 2. Results of Searching Method II

Text length	Relevant Results	Total Results	Accuracy
2 (e.g. in)	Not applicable	160	-
3 (e.g.dua)	4	8	50%
4 (e.g.ubat)	9	10	90%
5 (e.g. batik)	57	74	77%
6 (e.g. tarian)	1	1	100%

Table 3. Results of Searching Method III

Text length	Relevant Results	Total Results	Accuracy
2 (e.g. in)	0	0	100%
3 (e.g. dua)	7	8	87.5%
4 (e.g. ubat)	9	9	100%
5 (e.g. batik)	67	67	100%
6 (e.g. tarian)	1	1	100%

Based on the result in Table 1, there is no issue as far as Searching Method I is concerned. However, in Searching Method II, there are issues if short texts are used. It is found that the search engine takes into account, words which contain the search string of the keyword. Short words such as “is”, “in” or “to” commonly appear in longer words, and they lead to more search results which may not be relevant to the users. Searching Method III reduces the irrelevant results as the system identifies a more specific user query from the selection menu. For example, figure 1 and figure 2 show the different result returned by the search engine. Figure 2, which is using the Searching Method III return a more specific result.

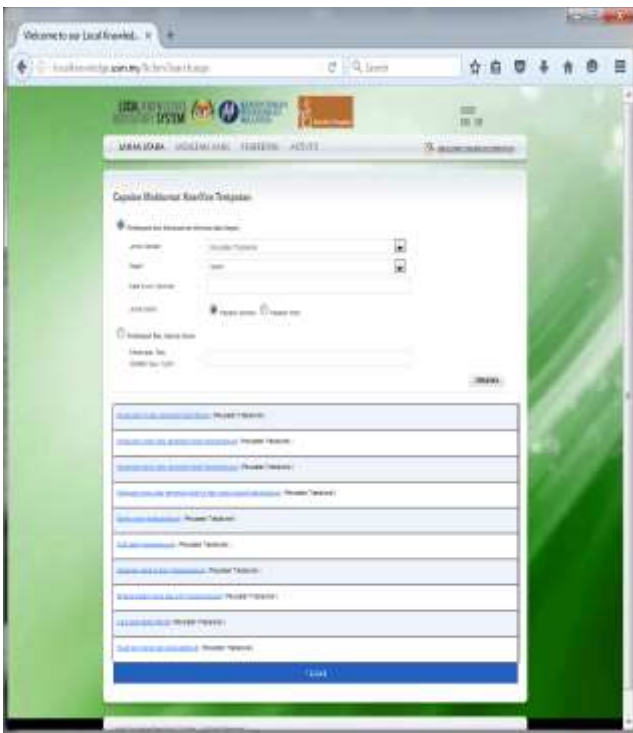

Figure 1. Search Result Using Method I



Figure 2. Search Result Using Method III

Figures 3-6 show some sample screenshots of the web application. Figure 1 shows the interface for selecting the type of search which the user desires. Figure 2 shows the search results which are displayed in the form of a map. The user is also able to display the results in tabular form as shown in Figure 3. Figure 4 shows the search results based on keywords. The keywords are highlighted to ease the user to look at the words which appears in the search results. An option to suggest keywords are also included to narrow down the search results.



Figure 3. Search Menu



Figure 4. Search Results in Map Form



Figure 5. Search Results in Tabular Form



Figure 6. Search Results with Highlighted Keywords in Tabular Form

V CONCLUSION AND FUTURE WORK

In conclusion, the improved searching method (Searching Method III) is able to provide an effective search feature for the users to query local knowledge information. By providing different searching methods such as search by selection method, search by keywords or a combination of both (the proposed searching method), the users are able to search the most relevant information based on their requirements.

For future work, images reflecting the local knowledge will be considered. Each image will be characterized and indexed into various categories which allows the users to search for images from the keywords. In addition, the searching method will be further enhanced by using the natural language processing technique for more accurate search results.

ACKNOWLEDGEMENT

We would like to acknowledge the contribution of the Schools of Computer Sciences and Humanities, Universiti Sains Malaysia (USM) and the LRGS Grant (203/PTS/6727003) from USM.

REFERENCES

- Benferhat, S., & Garcia, L. (1996). A local approach to reasoning with conditional knowledge bases. *Proceedings Eighth IEEE International Conference on Tools with Artificial Intelligence, 1996* (pp.404-407). France: IEEE.
- Damtew, Z. (2010). Using local knowledge in information gathering process: Case study from Ethiopia. *Proceedings of the IST-Africa 2010* (pp. 1-7). Durban: IEEE.
- Duan, J., Subramanian, N., & Abdulrahman, M. (2013). Knowledge management in the Chinese local beer market: A case study. *IEEE International Conference on Industrial Engineering and Engineering Management (IEEM)*, (pp. 58-62). Bangkok.
- Inthiran, A., Alhashmi, S., & Ahmed, P. (2010). A Reflection of Current Search Engine Techniques on Medical Search Environments. *Sixth International Conference on Intelligent Environments (IE), 2010* (pp. 170-173). Kuala Lumpur: IEEE.
- Kawano, H. (2000). Overview of Mondou Web search engine using text mining and information visualizing technologies. *International Conference on Digital Libraries: Research and Practice* (pp. 234-244). Kyoto: IEEE.
- Khan, J., Sangroha, D., Ahmad, M., & Rahman, M. (2014). A performance evaluation of semantic based search engines and keyword based search engines. *International Conference on Medical Imaging, m-Health and Emerging Communication Systems (MedCom)* (pp. 168-173). Greater Noida: IEEE.
- Killoran, J. (2013). How to Use Search Engine Optimization Techniques to Increase Website Visibility. *IEEE Transactions on Professional Communication*, 56(1), 50-66.
- Lovic, S., Lu, M., & Zhang, D. (2006). Enhancing Search Engine Performance using Expert Systems. *IEEE International Conference on Information Reuse and Integration* (pp. 567 - 572). Waikoloa Village, HI: IEEE.
- Tumer, D., Shah, M., & Bitirim, Y. (2009). An Empirical Evaluation on Semantic Search Performance of Keyword-Based and Semantic Search Engines: Google, Yahoo, Msn and Hakkia. *Fourth*

International Conference on Internet Monitoring and Protection, 2009 (ICIMP'09) (pp. 51-55). Venice/Mestre: IEEE.

van Splunter, S., van Langen, P., & Brazier, F. (2005). The role of local knowledge in complex Web service reconfiguration. *The 2005*

IEEE/WIC/ACM International Conference on Web Intelligence (pp. 495-499). Netherlands: IEEE.

Knowledge Management Systems Success Model for Higher Education Institutions: A Partial Least Square Approach

Nor'ashikin Ali, Zaihisma Che Cob, and Hidayah Sulaiman

Universiti Tenaga Nasional, Malaysia, {shikin; zaihisma; hidayah} @uniten.edu.my

ABSTRACT

The implementation of Knowledge Management (KM) in various organizations including higher education institutions (HEIs) have provided significant benefits in making the best use of knowledge in meeting organizational strategic objectives. This study reports the findings of the factors that influence the success of knowledge management systems (KMS) in higher education institutions (HEIs). The KMS success model for HEIs was proposed and tested to 204 academicians in Malaysian public universities using partial least square approach. Out of seventeen hypotheses, fifteen hypotheses were supported. It was found that perceptions of usefulness of KMS and satisfaction levels of academicians play important roles in determining KMS success in higher education. These perceptions require the support of organizational factors such as leadership, incentive, culture of sharing, subjective norm, and training. The KMS success model developed in this study can help stakeholders in implementing successful KMS in higher education.

Keywords: higher education; knowledge management; success factors; success model.

I INTRODUCTION

The convergence of information and communication (ICT) accelerates the shift to the trend of global knowledge-based economy. This trend has caused the company's value to be associated with the strategic resource that is employees' knowledge. Similar to other knowledge-based industries, higher educational institutions (HEIs) are highly dependent on the experience and knowledge of its employees, mostly tacit in nature, for their survival in the market. The employees' knowledge is the largest asset of HEIs as it is the key ingredient of innovation (Omerzel, Biloslavo, Trnavčević, & Trnavčević, 2011). Therefore, this asset is of significant importance, hence must be protected and preserved in a globalized educational environment (Altbach, 2015). To generate value from this asset, the active and dynamic implementation and management of knowledge is required in HEIs.

HEIs, whose activities involve the continuous capturing, generating, and disseminating of knowledge through the use of information and

communication technology (ICT), are perceived to have some level of KM (Rowley, 2000). For example, the use of online social networking such as facebook, twitter, and other ICT such as email, video conferencing, and portal has increased as an education platform to accumulate and share knowledge between students and lecturers in HEIs (Benson, Morgan, & Tennakoon, 2012). These are Knowledge Management Systems (KMS), the KM tools which support people engaged in knowledge work, and a mediating tool for collaboration.

Despite the availability of these tools, organizations are facing the challenges in getting people to participate resulting KMS to fail. Therefore, for universities to have successful KM, they should first understand the factors that can contribute to the success of KMS. Although a number of studies have reported the implementation of KM in HEIs (Benson, Morgan, & Tennakoon, 2012; Brewer & Brewer, 2010; Cranfield & Taylor, 2008), these studies did not pay attention to the factors that can promote KMS success in HEIs. As organizational setting in HEIs is different from other business organizations, it is expected that knowledge might not be managed in a similar fashion, and the existing KMS success model may not be suitable to be applied in HEIs. Thus, it is important that a success model for KMS be developed for HEIs as a guideline in implementing their successful KMS. The objective of this paper is to investigate the factors that contribute to the success of KMS in HEIs by considering technological and organizational factors, and thus develop a KMS success model for HEIs.

II BACKGROUND

Knowledge management is defined as a process of managing knowledge through the activities of generation, storing, sharing, and application of knowledge (Alavi & Leidner, 2001; Davenport, DeLong, & Beers, 1998). The challenge of organizations is to get employees to voluntarily contribute to the KMS. Employees' willingness to share knowledge is a key element in the implementation and success of any knowledge-management endeavor.

The KM activities in organizations are facilitated by the use of KMS. Two important functions of KMS are to store useful documents and knowledge via knowledge repository that are accessible by other

organizational members, and to serve as a network of experts that help organizational members find individuals with particular expertise (Davenport et al., 1998). Both of the functions of KMS enable individuals to share their knowledge and retrieve knowledge for use.

Despite the availability of KMS, KM initiatives cannot guarantee to be successful if the employees are not willing to share their knowledge. Contrary to computer information systems, KMS involve more human activity for creating repository for lessons learned, and best practices, as well as for interactions with others for providing expertise. This predicament has led researchers to conduct studies on KMS success.

A. Previous KMS Success Studies

Previous studies on KMS success were conducted in business organizations (Wu & Wang, 2006; Halawi, McCarthy, & Aronson, 2008; Hwang, Chang, Chen, & Wu, 2008). These studies focus on the technological factors such as content quality, system quality as well as attitudes towards the KMS. While these insights are important to note, these studies did not address the human dimension (referred to as people dimension in KM literature), which is very much crucial for the success of KM in organization. Based on the view that KMS is more cultural issues than technological issues, Kulkarni, Ravindran, and Freeze (2007) developed a KMS success model in one of the universities in US by integrating organizational factors and technological factors. Organizational factors that were proposed in their KMS success studies are leadership, incentives, and role of supervisors and coworkers. These organizational factors were found to be contributing factors to the success of KMS.

Similarly, Lee and Roth (2009) developed a conceptual framework that proposed organizational factors to be examined as part of KM strategy in HEIs. They viewed that organizational factors such as leadership, incentives, the influence from their peers as well as cultural of sharing are needed for effective KM. The importance of linking cultural and organizational factors to the effective knowledge management initiatives has also been highlighted in the study of KM in HEIs (Khalil & Shea, 2012; Mathew, Rodrigues, & Vittaleswar, 2012).

The previous studies of KMS success were mainly in business organizations, and there are no studies of KMS success being conducted in HEIs. Although prior research of KM in higher education place emphasis on the importance of organizational factors, they lack empirical evidence. Specifically, the important organizational factors such as leadership, culture of sharing, incentive, subjective norm, and

training were not addressed in any empirical studies of KMS in HEIs. Therefore, this study aims to bridge this gap by integrating these organizational factors and technological factors in the KMS success model.

III RESEARCH MODEL

A KMS success model developed in this study considers the technological factors: knowledge content quality, KM system quality, user satisfaction, and perceived usefulness. Knowledge content quality, KM system quality, and user satisfaction are derived from DeLone and McLean IS success model (DeLone and McLean, 2003), while perceived usefulness is derived from Technology Acceptance Model (TAM) founded by Davis (1989). The organizational factors to be integrated are leadership, culture of sharing, incentive, subjective norm, and training.

Knowledge content quality (KCQ). With the advanced information and communication technology such as electronic discussion forum, emails, and intranet, it is much easier for academicians to share their knowledge. If the knowledge is of high quality, then using electronic discussion forum to share knowledge may be perceived as useful. This has been confirmed by the previous studies, which suggested that knowledge content quality has a positive impact on KMS success via perceived usefulness of KMS (Wu and Wang, 2006).

KMS System Quality (KMS SQ). KMS system quality is how well the system meet needs and expectation of users and organizations (Wu and Wang, 2006). The quality of functions provided by KMS such as reliable, accessible, and easy to use are perceived to influence the use of KMS. The system that is not stable, not user-friendly, difficult to use, not reliable and accessible is likely to be abandoned by the users (especially if they are 'technophobic'). Academicians have to access high volume of knowledge for their teaching and research, thus, having a high quality system is likely to increase their belief on the usefulness of KMS for sharing and accessing knowledge. Prior studies have proven the significance of system quality in influencing the KMS Use via Perceived Usefulness (Kulkarni et al., 2007; Wu and Wang, 2006).

User Satisfaction (US). User Satisfaction in this study is measured on user satisfaction with the sharing and retrieval capabilities of the KM system, the adequacy and quality of knowledge needed, and user satisfaction that the system can enhance job performance. Wu and Wang (2006) found that user satisfaction gives positive impact to KMS use and Kulkarni et al. (2007) found that user satisfaction with KM initiatives significantly affects knowledge use. In this study, it is perceived that academicians who are satisfied with KMS are more inclined to use KMS.

Perceived Usefulness (PU). Perceived usefulness is defined as "the degree to which a person believes that using a particular system would enhance his or her job performance" (Davis, 1989, p. 320). Davis (1989) asserts that the tendency to use the system is higher if they believe that using the system can improve their performance. Wu and Wang (2006) in their studies assert that PU had a strong and positive effect on KMS success. Similarly, in HEIs, it is perceived that PU may affect KMS success.

Training (TR). In this study, training is defined as the exposure given to the academicians with regards to KM and KMS, such as training via seminars, workshops, etc. An individual can be trained about information systems through college courses, vendor training, in-house training, and self-study. Training is posited to facilitate user participation (Sabherwal, Jeyaraj, and Chowa, 2006). In previous studies, training was found to affect behavior intention indirectly through facilitating condition and facilitating condition affects perceived usefulness (Aggelidis, and Chatzoglou, 2009). Training can enhance skills and confidence in using the KMS, and thus, enables users to overcome knowledge barriers to successful implementation of KMS.

Subjective norm (SN). Subjective norm is defined as the degree to which an academician perceives that his/her colleagues believes he or she should or should not perform (that is contribute or seek knowledge via KMS). Subjective norm is perceived to shape a person's intention to perform a behavior (Ajzen, 1991). In this study, subjective norm is perceived to be an important factor to influence academicians to share or retrieve knowledge through perceived usefulness of KMS.

Culture of sharing (CS). Alavi, Kayworth, and Leidner (2006) believe that organizations whose culture do not value and support knowledge sharing will face difficulties in integrating KMS. A knowledge friendly organizational culture is viewed as one of the most important conditions for the success of KM initiatives in organizations (Davenport et al., 1998). Cultural values, such as knowledge-friendly culture, openness, and trust will lead to positive KM behaviors (Alavi et al., 2006; Ciganke, Mao, and Srite, 2008).

Leadership (LS). Various terms are used to refer to 'leadership' such as chief executive officers or top management (Singh, 2008). Kulkarni et al. (2007) describe leadership as the commitment of top levels of management in all KM activities.. They posited that leaders can influence the behavior of employees, and they have the ability to change employees' behavior towards implementation of KMS. Similarly in HEIs, Mathew et al. (2012) posited that the consistent and continued support of the top management is important for the KMS success

1) *Incentive (INC).* Incentives, defined as some forms of recognition given to the employees to encourage sharing of knowledge, has been highlighted in previous studies as a critical element for KMS success that must not be overlooked (Kulkarni et al., 2007). Markus (2001) viewed that the use of incentives is a way to recognize the efforts of knowledge contributors, who are frequently expected to produce high quality knowledge content. In higher education, the rewards should stimulate more contribution of knowledge sharing with high quality of knowledge content. Hence, incentives are perceived to influence knowledge content quality as well as KMS use for Sharing.

The outcome variables for this study are KMS use for sharing and KMS use for retrieval. These variables measure the use of KMS from the tasks they use KMS for, not the amount of use (Wu and Wang, 2006; Kulkarni et al., 2007; He and Wei, 2009). These variables reflect the two functions of KMS as knowledge repository and network of experts. The resulting KMS success model and its hypotheses are shown in Figure 1.

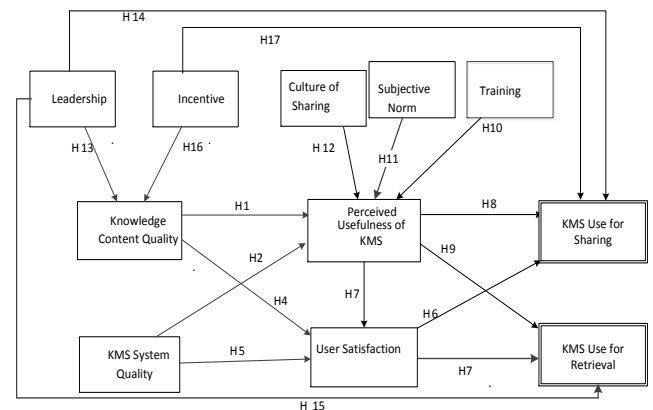

Figure 1: A Proposed KMS Success Model for Higher Education Institutions

IV RESEARCH DESIGN AND METHOD

The survey was sent to 950 academicians in Malaysian public universities; they are local lecturers, tutors, and foreign lecturers. In each survey, the definition of KMS was included as the introductory note of the survey. The survey was divided into two sections. The first section requires the respondent to indicate his or her degree of agreement with each item using a seven-point Likert scale (1=Strongly disagree, 7=Strongly agree). The second section was on the respondent's profile. The respondents were asked to complete both sections. A link to an online survey was sent to the academicians via email, followed by the first reminder two weeks later. The last reminder was sent a week after the second reminder. A total of 204 completed questionnaires (response rate was about 21.4%) were used in the analysis.

V DATA ANALYSIS AND RESULTS

This paper employs the partial least squares (PLS) technique to validate our model. The PLS, is a second generation statistical analysis software that is widely used in the IS field. PLS simultaneously models structural and measurement paths (Chin, 1998). The recommended sample size in PLS is at least 10 times the number of independent variables. There are two steps in the process of theory testing: (1) developing valid measures of theoretical constructs; and (2) testing the relationship between theoretical constructs.

A. Assessment of Measurement Model

The measurement model was tested with respect to individual item reliability, internal consistency, and convergent and discriminant validity. The construct validity was assessed by item reliability and convergent validity of scale items was assessed using three criteria suggested by Fornell and Larcker (1981): (1) all item factor loadings should exceed 0.70, (2) composite reliability (CR) for each construct should exceed 0.80, and (3) average variance extracted (AVE) for each construct should exceed 0.50. In this study five items had factor loading values lower than 0.7 and were therefore, deleted from consideration, leaving a total of 67 items for further analysis. Five items that were found less than 0.7 are in the following constructs: (1) knowledge content quality (1 item); (2) leadership (2 items); (3) user satisfaction (1 item); (4) KMS system quality (1 item). Internal consistency was assessed by looking at the composite reliability (CR) value. Composite reliabilities of all constructs (after dropping five items) exceeded the required minimum of 0.80. Further, the AVEs ranged from 0.64 to 0.75 which are well above the recommended threshold of 0.50, exhibiting acceptable convergent validity. The square root of AVE is between 0.80 and 0.87, which exceeds the correlations with the other constructs exhibited discriminant validity.

B. Assessment of Structural Model

The test of the structural model includes estimating the path coefficients (the strengths of relationship between the dependent and independent variables) and the R^2 value (the amount of variance explained by independent variables). SmartPLS was chosen using a bootstrap resampling method (500 resamples) to determine the significance of the paths within the structural model. The PLS results of the analysis are shown in Figure 2. Out of seventeen hypotheses, fifteen hypotheses were supported.

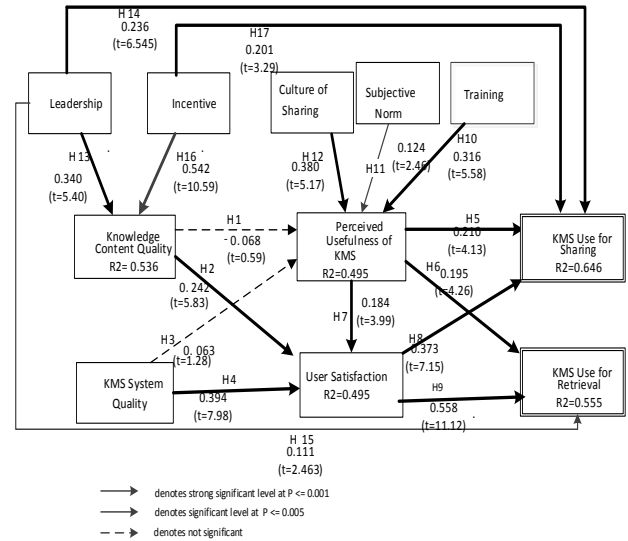

Figure 2. PLS Analysis of Research Model

As shown in Figure 2, approximately 65 percent ($R^2 = 0.646$) of the variance in KMS use for sharing, 55 percent ($R^2 = 0.555$) of the variance in KMS use for retrieval, 49 percent ($R^2 = 0.495$) of the variance in PU and US respectively, and 54 percent ($R^2 = 0.536$) of the variance in KCQ are explained. The standardised path coefficients ranged from 0.124 to 0.558, with eleven of the fifteen paths exceeding the suggested minimum value of significance at 0.20 (Chin 1998). Thus, the fit of the overall model is good. The results show that PU (path coefficient = 0.210, $p \leq 0.001$) and US (path coefficient = 0.373, $p \leq 0.001$) were found to affect KMS use for sharing.

The effect of PU (path coefficient = 0.426, $p \leq 0.001$) and the effect of US (path coefficient = 0.558, $p \leq 0.001$) on KMS use for retrieval are more than the effect on KMS use for sharing, which is consistent with the study by Wu and Wang (2006), and Hwang, Chang, Chen and Wu (2008). These findings indicate that PU and US should be the concern of higher education in implementing successful KMS. It was found that TR (path coefficient = 0.316, $p \leq 0.005$) had a significant effect on PU, which is consistent with the study by Arntzen and Ndlela (2009). However, KCQ and KMS SQ were found to have no significant effect to PU. It was found that CS (path coefficient = 0.38, $p \leq 0.005$) and TR (path coefficient = 0.316, $p \leq 0.005$) had a significant effect to PU. The culture of sharing seems to be important to influence the perception of KMS's usefulness among academicians and thus, supports the view of Wang, and Noe (2010) that culture may contribute to the success of KM initiatives. The insignificant result of KMS SQ and KCQ on PU implies that these two factors may not be their priorities in their perceptions of usefulness of KMS as long as they have good knowledge sharing culture,

good support from their peers, and are sent for training. System quality and content quality may be important during the initial implementation but for a long term commitment, cultural factor should be given more attention.

The significant effect of KMS SQ, KCQ, and PU on US implies that these factors are needed to fulfill the academicians' satisfaction towards using the KMS. The results also show that LS (path coefficient = 0.34, $p \leq 0.005$) and INC (path coefficient = 0.542, $p \leq 0.001$) had strong effect on KCQ, which support the findings of Kulkarni et al.'s (2007) study in business organizations. This result implies the support from leaders and some incentives can influence the contribution of high quality of knowledge content.

VI DISCUSSIONS

This study examined the factors contributing to KMS success by looking at technological and organizational factors that influence KMS use for sharing and retrieval. It was motivated by the need to develop a model incorporating the organizational and technological factors that may contribute to the success of KM initiatives in HEIs.

A. Limitations of the Study

There are several limitations of this study, requiring further examination and additional research. One limitation is this study is based on general KMS., not specific KMS. Some universities may use KMS specifically designed for their organizations and this study may not provide the same finding. For the study of specific KMS in an organization, future research may use a single case study to achieve an in-depth, qualitative understanding of the object of investigation: to investigate factors that influence a purpose-built KMS. Finally, the sample size is limited may be due to KMS being new in HEIs and not many really use KMS to share knowledge. Although the sample size is acceptable for PLS analysis, a larger and more heterogeneous sample would bring more statistical power.

B. Implications for Theory

From a theoretical perspective, our findings imply that technological factors by themselves are insufficient to KMS success. Knowledge content quality, KMS system quality, perceived usefulness and user satisfaction can contribute to KMS success to some extent but it is organizational factors (e.g. culture of sharing, incentives, and training) that contribute more to KMS success in terms of use of KMS for sharing and retrieval. The distinction between KMS use for sharing and KMS use for retrieval is an important distinction, which should receive more attention in determining the factors for KMS success. The result of incentive being a factor that has a greater effect on

KMS success than other factors may have indicate that in HEIs, incentive is needed to promote their academic staff either to contribute their knowledge to KMS or to retrieve knowledge from KMS. This is contrary to other organizations, where incentive did not have much effect on KMS success. The results also indicate that there is an empirical evidence that a culture of sharing is a pre-condition necessary for KMS success, which was not empirically tested previously due to its complex domain.

C. Implications for Practice

The findings of this study have important implications for HEIs interested in implementing KMS and how to leverage the KMS for competitive advantage. Leaders such as a Vice Chancellor, Deans and Head of Departments play important roles in motivating academicians to share and retrieve knowledge from KMS. They should set an example in promoting the high quality of shared knowledge and its reuse. It is important that they model appropriate behaviors in using the system to share and retrieve knowledge. Thus, it opens a credibility gap with respect to employee belief and trust in KMS.

The management of HEIs may consider of rewarding those academicians, who contribute high quality knowledge and those who use and apply knowledge to their work that may impact organizational performance. Management of HEIs should focus on building up the practice of knowledge sharing such as providing more opportunities for academicians to participate in the workshops, seminar, conferences, and share with other colleagues in their universities. Wang, Noe and Wang (2014) found that employees who were explicitly rewarded for knowledge sharing would make greater knowledge contributions to the KMS compared with those who were not given the rewards. In addition, training should also be part of KM strategy to provide skills needed by employees in using KM effectively. Providing training to employees can overcome barriers of the usage of the system due to the technical complexity of the system (Sharma & Yetton, 2007).

VII CONCLUSION

This study presented a theoretical model of KMS success in HEIs presenting the factors contributing to the success of KMS in HEIs. This study enhances the understanding of factors contributing to KMS in organizations in general and in HEIs in particular. It can be guidelines for higher education stakeholders in implementing successful KMS. The resulting model was empirically validated using a survey of academicians in HEIs in Malaysia. Overall, the results demonstrate the importance of organizational factors in addition to technological factors to ensure the success of KMS in higher education. This study

supports the KM researchers' view that KM is more of organizational issues than technological issues. Future researchers may need to investigate other organizational factors that are not listed in this study, and to examine in greater depth this area of research.

ACKNOWLEDGMENT

The authors would like to extend our great appreciation to University Tenaga Nasional, Malaysia for funding this project. We would also like to thank our graduate research assistant, Ahmed Salami for his help in data collection.

REFERENCES

- Ajzen, I. (1991). The theory of planned behavior. *Organizational behavior and human decision processes*, 50(2), 179-211.
- Aggelidis, V. P., & Chatzoglou, P. D. (2009). Using a modified technology acceptance model in hospitals. *International Journal of Medical Informatics*, 78(2), 115-126.
- Alavi, M., & Leidner, D. E. (2001). Review: Knowledge management and knowledge management systems: Conceptual foundations and research issues. *MIS Quarterly*, 107-136.
- Alavi, M., Kayworth, T. R., & Leidner, D. E. (2006). An empirical examination of the influence of organizational culture on knowledge management practices. *Journal of Management Information Systems*, 22(3), 191-224.
- Altbach, P. (2015). Knowledge and education as international commodities. *International Higher Education*, (28).
- Arntzen, A. A. B., & Ndlela, M. N. (2009). *Success factors in implementing knowledge based systems*. Academic Conferences Limited.
- Benson, V., Morgan, S., & Tennakoon, H. (2012). A framework for knowledge management in higher education using social networking. *International Journal of Knowledge Society Research (IJKSR)*, 3(2), 44-54.
- Brewer, P. D., & Brewer, K. L. (2010). Knowledge management, human resource management, and higher education: a theoretical model. *Journal of Education for Business*, 85(6), 330-335.
- Ciganke, A. P., Mao, E., & Srite, M. (2008). Organizational culture for knowledge management systems: a study of corporate users. *International Journal of Knowledge Management (IJKM)*, 4(1), 1-16.
- Cranfield, D. J., & Taylor, J. (2008). Knowledge Management and Higher Education: A UK Case Study. *Electronic Journal of Knowledge Management*, 6(2).
- Chin, W. *The partial least squares approach to structural equation modeling*, Marcoulides GA, Modern Methods for Business Research, 1998. LEA, New Jersey.
- Davenport, T. H., De Long, D. W., & Beers, M. C. (1998). Successful knowledge management projects. *MIT Sloan Management Review*, 39(2), 43.
- Davis, F. D. (1989). Perceived usefulness, perceived ease of use, and user acceptance of information technology. *MIS Quarterly*, 319-340.
- Delone, W. H., & McLean, E. R. (2003). The DeLone and McLean model of information systems success: a ten-year update. *Journal of management information systems*, 19(4), 9-30.
- Fornell, C., & Larcker, D. F. (1981). Evaluating Structural Equation Models with Unobservable Variables and Measurement Error. *Journal of Marketing Research (JMR): American Marketing Association*.
- Halawi, L. A., McCarthy, R. V., & Aronson, J. E. (2008). An empirical investigation of knowledge management systems' success. *Journal of Computer Information Systems*, 48(2), 121-135.
- He, W., & Wei, K. K. (2009). What drives continued knowledge sharing? An investigation of knowledge-contribution and-seeking beliefs. *Decision Support Systems*, 46(4), 826-838.
- Hwang, H. G., Chang, I. C., Chen, F. J., & Wu, S. Y. (2008). Investigation of the application of KMS for diseases classifications: A study in a Taiwanese hospital. *Expert Systems with Applications*, 34(1), 725-733.
- Khalil, O. E., & Shea, T. (2012). Knowledge sharing barriers and effectiveness at a higher education institution. *International Journal of Knowledge Management (IJKM)*, 8(2), 43-64.
- Kulkarni, U. R., Ravindran, S., & Freeze, R. (2007). A knowledge management success model: theoretical development and empirical validation. *Journal of management information systems*, 23(3), 309-347.
- Lee, H. Y., & Roth, G. L. (2009). A conceptual framework for examining knowledge management in higher education contexts. *New Horizons in Adult Education and Human Resource Development*, 23(4), 22-37.
- Markus, M. L. (2001). Toward a Theory of Knowledge Reuse: Types of Knowledge Reuse Situations and Factors in Reuse Success. *Journal of Management Information Systems*, 18(1), 57-93.
- Mathew, A. O., Rodrigues, L. L., & Vittaleswar, A. (2012). Human Factors & Knowledge Management: A System Dynamics Based Analysis. *Journal of Knowledge Management Practice*, 13(2).
- Omerzel, D. G., Biloslavo, R., Trnavčević, A., & Trnavčević, A. (2011). Knowledge management and organizational culture in higher education institutions. *Journal for East European Management Studies*, 111-139.
- Rowley, J. (2000). Is higher education ready for knowledge management?. *International Journal of Educational Management*, 14(7), 325-333.
- Sabherwal, R., Jeyaraj, A., & Chowa, C. (2006). Information system success: individual and organizational determinants. *Management Science*, 52(12), 1849-1864.
- Sharma, R., & Yetton, P. (2007). The contingent effects of training, technical complexity, and task interdependence on successful information systems implementation. *MIS Quarterly*, 219-238.
- Singh, S. K. (2008). Role of leadership in knowledge management: a study. *Journal of Knowledge Management*, 12(4), 3-15.
- Wang, S., & Noe, R. A. (2010). Knowledge sharing: A review and directions for future research. *Human Resource Management Review*, 20(2), 115-131.
- Wang, S., Noe, R. A., & Wang, Z. M. (2014). Motivating knowledge sharing in knowledge management systems a quasi-field experiment. *Journal of Management*, 40(4), 978-1009.
- Wu, J. H., & Wang, Y. M. (2006). Measuring KMS success: A respecification of the DeLone and McLean's model. *Information & Management*, 43(6), 728-739.

Social Identity, Collective Engagement and Communal Patent For Successful Digital Collaboration

Olivia Fachrunnisa, Ardian Adhiatma, and Mustafa

Unissula Indonesia, Indonesia, {olivia.fachrunnisa;ardian;cakmustafa} @unissula.ac.id

ABSTRACT

This paper aims to develop a model of DCN (Digital Collaboration Network)'s sustainability based on social identity (social categorization, social identification and social comparison). Social identity takes a role as a glue for members of the community so that the sustainability of a community will be maintained. Furthermore, with a strong social identity, a DCN will produce a communal products and services. In order to protect product and service that has economic value and commercialized by members of the community, we need to endorse an intellectual rights property (communal patent). Collective engagement will also reinforce the sustainability of a collaborative network. This study will contribute to the efforts to maintain the sustainability digital collaboration by strengthening social identity and the creation of communal property. This study will use qualitative experimental design in which a framework will be designed to simulate and evaluate the implementation of social identity theory and the creation of communal property in the digital community.

Keywords: Social identity, collective engagement, communal patent, digital collaboration

I INTRODUCTION

The advance of information and communication technology brings a necessity for doing business in the future. Business entities should join in the digital collaboration network to improve their performance. It will be a must for such business to join in the community in order to get the maximum benefit of collaboration through digital network (Fachrunnisa, 2014). With this network, digital community easily produces complementary products and services that are more profitable (Fachrunnisa, Mutamimah, & Gunawan., 2013b, 2013a).

However, there has been no convention or lack of research which discusses the intellectual property of the product or service as outcomes of digital collaboration. This is due to the differences in interests between developing and developed countries. Developing countries are used to living

in social communities are unfamiliar with the laws of intellectual property rights on the community. This study aims to maintain the strength and sustainability of the digital collaboration network (DCN) by strengthening social identity and the creation of communal property over the products and services resulting from the collaboration activities in DCN and collective engagement that occurs in the community. Social identity theory has been widely discussed in the real environment that is based on physical contact, however, a study to identify how the process of strengthening the social identity for digital community has not been widely discussed. With the business ecosystem, sustainability and excellence of an industry collaboration will be formed. This is because members of the ecosystem will be able to support each other 'life' and 'existence' of them.

This research aims to develop a model and a measurement scale implementation of social identity theory and collective engagement for DCN member. The study is based on secondary data which collected from books, journals, magazines and the internet. The conceptual framework is developed to describe each policies and practices of its dimensions.

II LITERATURE REVIEW

A. Social Identity

Social identity is a feeling or sense of a person based on their membership in a group. (Tajfel & Turner, 1986) proposed that the group (i.e, social class groups, families, business groups) is an important source of pride and individual self-esteem. Group or community gives a sense of social identity such as feelings of belonging in social groups, gives an understanding the collaborative work within the group, across many domains of science. Collaboration in a group has been studied to achieve business objectives, to support and to maintain community as well as to ensure the positive benefit of group's work. In this study, we will investigate the benefits of

collaboration from the perspective of collaborators, and contribute to the topic of research topics related to digital communities or virtual communities.

Identity is a tool to understand individual actions, thoughts and even individual feelings when joining a community. This study focuses on the interactional identity in a business community, which is an important aspect of the identity of the majority of members of the community. The study also aimed to show that the identity is very meaningful to the power of a digital community. In short, such identity needs psychological and goal-directed manual interaction.

In cognitive framework, identity is understood as cognitive tools that can be used in the activities system. Identity is also often seen as something through a process, or as a result of an activity. Socio-cultural perspective needed to capture how the mechanism of incorporating people with the tools, institutions and identity; as well as how to limit the action, expand, and how they work as a tool for individual identities in a virtual community.

B. Communal Patent

ILO, a governing body of the UN has developed a concept called the CBED (Community Based Enterprise Development). CBED is the business development of a community-based enterprise. DCN as one of the digital business community meant to hold the perpetrators of business people to collaborate and set up a product or service featured by collaboration in the community. At the end, the product or service as a result of collaboration should have a patent, so it will improve product competitiveness in the world. Intellectual property has become one of the most important factors to improve the competitiveness of the nation. As the core of the intellectual property, patents serve as a basis for developing and operating intellectual property and build an innovation capacity.

The formation and development of educational pattern for patent in collaborative business community is very important. It can be used as one tool to maintain the sustainability of a digital community. Sustainability of a digital community has been widely discussed in the literature. One of the reasons why sustainability of this digital community is significance is because this community has a life cycle. The

existence of digital communities depends on the behavior of emerging and sustainable from its members (Buchotlz, 2005). This life cycle pattern follows the general pattern of life cycle phases, namely birth, expansion, leadership, updates and even to death (Moore, 2003). Therefore, a consistent effort is needed so that a virtual community can maintain its life cycle; if not, then this community will disappear. However, there is little research focuses on how digital communities can be sustained. In particular, there is no research that proposes and discusses metrics or measures to maintain virtual communities based on the strengthening of group identity and the creation of community-based patents.

The principle of social identity theory indicates that the results of the employee's behavior not only of self-identification and other categories, but also the content identity. Previous research shows that when organizational identification is high, individuals incorporate important aspects of the identity as organization's self-concept. Identify themselves with the organization can be interpreted as a member initiatives to take the nature and value of the group. After value and nature have incorporated into the self-concept, they have a major influence on the reference frame theory, objectives, exchange and other characteristics of inter-group exchange.

C. Collective Engagement

Engagement is a behavior that indicates the degree to which people moved to merge with their work in an organization. Individuals engagement with the tasks and objectives of the group will create a positive effect on the level of innovation and creation (Zhang & Bartol, 2010). Collective engagement is more than the aggregate amount of the individual's involvement in the organization (Bakker et al., 2006). Involvement has two basic components. First, members of the group must be aligned on a common goal and, secondly, they must be committed to mutually support each other's efforts (Kusari, Cohen, Singh, & Marinova, 2005). When members of each group involved in goal achievement, hence, shared information, shared values and shared vision will reinforce a mutual value. In the end, when member has full engage and focus on group objectives, the relationship of mutual support and individual

effort will produce group's energy, enthusiasm and focus on achieving common goals.

Moreover, group leader must understand how to translate individual collective engagement to organizational engagement. (Kahn, 1990) defines engagement as a more comprehensive description of the investment in the attitude of affective, behavioral and cognitive energy a person in the workplace. Collective engagement is a construct of organizational levels and is an indicator of the presence of the motivational environment within the organization (motivational aspect). While individual engagement based on a person's engagement to the organization, so that at this level, evaluative aspects predominate (Klein, Conn, Smith, & Sorra, 2001)

Collective Organizational Engagement will benefit the organization in some way. First, when the group members interact with each other, then they will share the positive elements behavior such as affective, motivational and attributes that can improve performance attributes such as collective efficacy and the potential for high group. Second, each member will be mutually comparing their input and output in the organization. This is known as social comparison process. Each member will compete to customize their engagement the group. Third, leaders are able to increase the level to which members feel connected and identify their destination with organizational goals, which at a later stage will override his desire to achieve organizational goals are more valuable (Piccolo & Colquitt, 2006). Therefore, collective engagement increases organizational value through the improvement organizational performance.

III CONCEPTUAL FRAMEWORK

We proposed a conceptual model derived from identity theory and engagement theory. Identity theory comes from their interactions with the symbiotic and individual identity. The pattern of

organizational strength and identity of self-identification will form group strength. Meanwhile, group norms derived from engagement theory which explains that individual engagement and organizational engagement is a strength of a group. Thus, social identity and collective engagement can be recommended as a determinant of group performance. A model of proposition for social identity and group involvement as capital networking and collaboration are presented in Figure 1.

Such group will have a meaning if it is able to contribute to the members and the surrounding environment. If members understand the characteristic of digital collaboration, vision and mission of the group, then one of determinant the group performance is having a capital to collaborate. A strong social identity and collective engagement that high would be the determinant of group performance. To seek engagement with members of the group, we have to see something meaningful from the investment of time, energy and mind when joining the organization.

Identity of digital social collaboration network is derived from a common vision: digitalization. Those identities are: digital worldview, digitalization of product and service and creator of digital goods and services that benefit the community and surrounding environment. While at the level of collective engagement, it can be categorized into spiritual engagement, emotional engagement, physical engagement and intellectual engagement. Communal patent performance can be measured from strong leadership, high integrity of the members of the group, deliverability to the user group's mission and vision and ability to sustain the group in the long term. The proposed conceptual is presented in Figure 2.

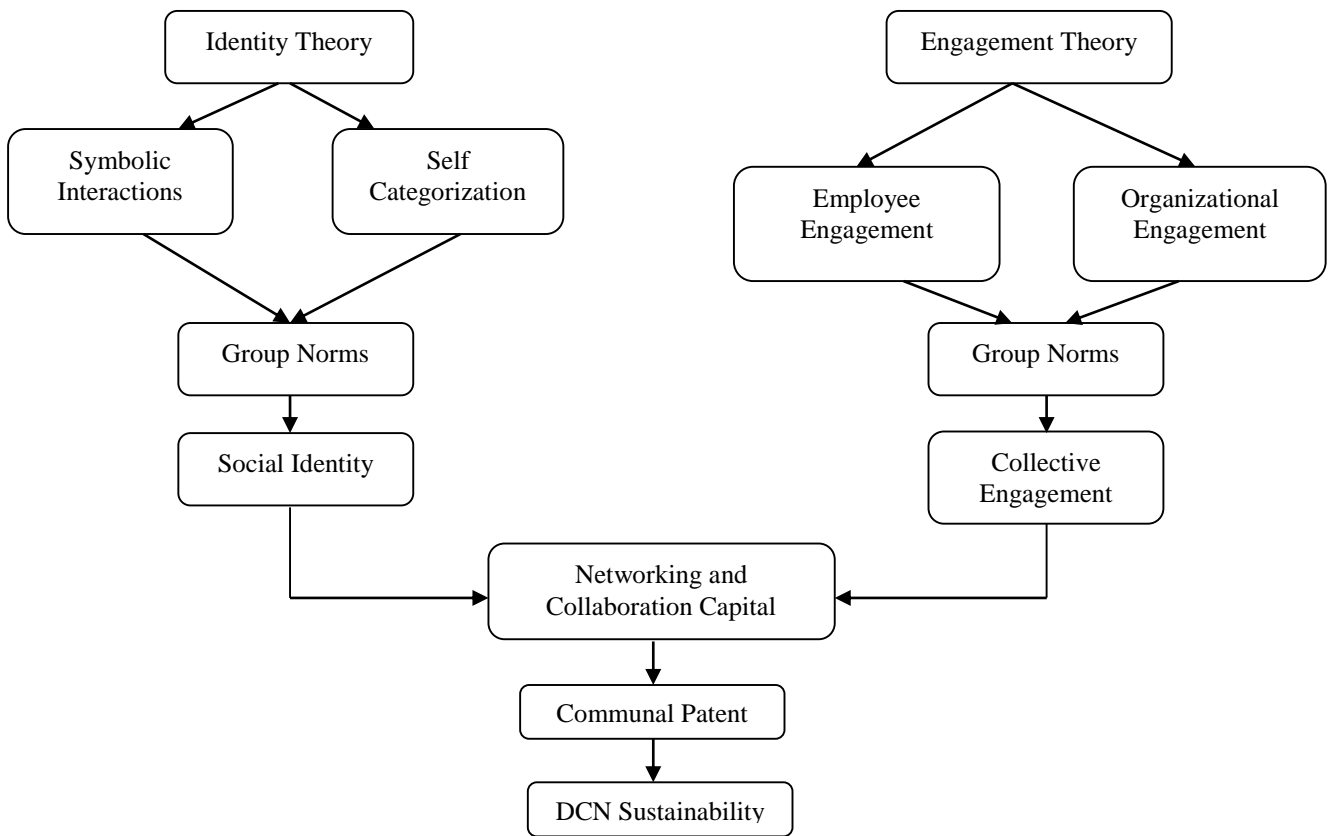

Figure 11. A Grand Theory of Social Identity and Engagement

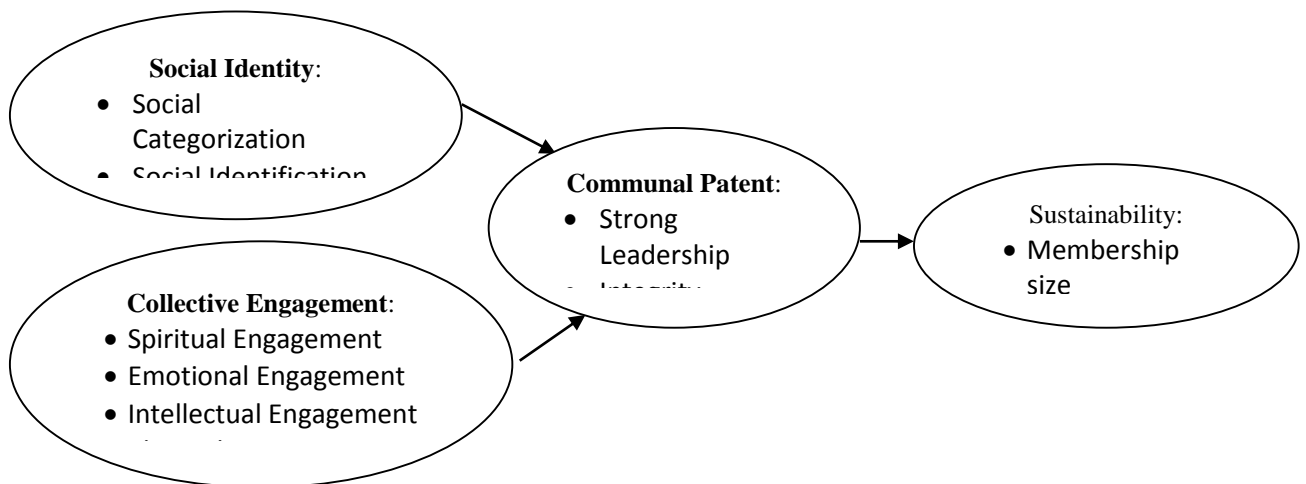

Figure 12. A Conceptual Model of Social Identity and Collective Engagement for DCN Sustainability

In this study the concept of social dimension, collective identity and engagement will affect the dimensions of sustainability through communal patent. Dimensions of social identity consists of; social categorization, social identification, and social comparison, while the dimensions collective engagement, consist of: spiritual engagement, emotional engagement, intellectual engagement, physical engagement which will affect communal Patent. Communal patent can be form of strong leadership, integrity, and delivery. This communal patent will affect community sustainability.

IV CONCLUSION

A digital collaborative group composed of members who have a common goal and are willing to cooperate in order to achieve community goals. When members agreed to link in a network, it would require several strategies to maintain the performance of the group or the network. Social identity and collective engagement are proposed as two organizational factors to create communal patent. Those two variables must be grown in order to improve network quality group. The social identity as a boundary spanning's provision to interact with external stakeholders. It is a special identifier that distinguishes the organization's existence with other organizations. Boundary spanning is an organization member that crosses boundaries as a branding for the organization or group of organizations.

The social identities of digital collaboration network are: digital worldview, digitalization of product and service, and good vision to build a digital product and service. In addition, collective engagement as a member attachment into their organization can be strengthened with spiritual engagement, emotional engagement, physical engagement and intellectual engagement. Those two organizational resources will take roles as a capital to form communal patent in collaboration networks. Managerial policy that can be

recommended to improve the quality of the network is to strengthen the social identity, giving a clear formulation of practical work program to construct communal patent.

A future research agenda includes validating and testing the propose model into quantitative or qualitative approach to make sure that the framework will contribute to the effort to maintain DCN's sustainability.

REFERENCES

- Bakker, A. B., & , & Schaufeli, W. B. (2000). Burnout contagion processes among teachers. *Journal of Applied Social Psychology and Marketing*, 30, 2289-2308.
- Bucholtz, M. (2005). Identity and interaction: A sociocultural linguistic approach *Discourse Studies*, 7(4-5), 585-614.
- Fachrunnisa, O. (2014). A simulation-based framework of performance monitoring and incentive mechanism for successful interactions in virtual environment *International Journal of Networking and Virtual Organisation (IJNVO)*, 14(3), 239-265.
- Fachrunnisa, O., Mutamimah, & Gunawan. (2013b). Trust, Self Regulation and Social Movement: Partner Selection at Digital Collaboration Network for SME's Sustainability *International Journal of Trade, Economics and Finance*, 3(6).
- Fachrunnisa, O., Mutamimah, & Gunawan. (2013a). *Digital Collaboration Network for SMEs: Awareness of ICT and Perceived Outcome*. Paper presented at the Paper presented at the 2013 Seventh International Conference on Complex, Intelligent, and Software Intensive Systems, Portugal.
- Kahn, W. A. (1990). Psychological conditions of personal engagement and disengagement at work. *Academy of Management Journal*, 33, 692-724.
- Klein, K. J., Conn, A. B., Smith, D. B., & , & Sorra, J. S. (2001). Is everyone in agreement? An exploration of withingroup agreement in employee perceptions of the work environment. *Journal of Applied Psychology*, 86, 3-16.
- Kusari, S., Cohen, D., Singh, J., & , & Marinova, D. (2005). *Trust and Control Mechanism in Organizational Boundary Spanners' Cognitions and Behaviors*. . Paper presented at the Paper presented at the Academy of Management Best Conference Paper.
- Moore, J. F. (Producer). (2003). Digital Business Ecosystems in Developing Countries: An Introduction, Berkman Centre for Internet and Society, Harvard Law School. . Retrieved from <http://cyber.law.harvard.edu/bold/develo3/modules/episodeII.html>.
- Piccolo, R. F., & Colquitt, J. A. (2006). Transformational leadership and job behaviors: The mediating role of core job characteristics. *Academy of Management Journal*, 49.
- Tajfel, H., & , & Turner, J. (1986). *The social identity theory of intergroup behavior*. In S. a. A. Worchel, W.G (Ed.), *Psychology of Intergroup Relations* Chicago: IL: Nelson-Hill.
- Zhang, X., & Bartol, K. M. (2010). Linking empowering Leadership and Employee Creativity: The Influence of Psychological Empowerment, intrinsic motivation, and Creative Process Engagement. *Academy of Management Journal*, 53(1), 107-128.

Observed Demographic Differentials in User Perceived Satisfaction on the Usability of Mobile Banking Applications

Emmanuel O.C. Mkpjoju, Nor Laily Hashim, and Rabi Adamu

Universiti Utara Malaysia, Malaysia

emelnuel@hotmail.com, laily@uum.edu.my, rabiadamu100@gmail.com

ABSTRACT

Mobile banking (m-banking) is a current technological innovation in mobile commerce. The growth of the mobile phone market opens an ever increasing opportunity for the expansion and penetration of the m-banking enterprise with its attendant business gains. However, the context of use of m-banking portends great challenges especially with respect to mobile usability. The peculiarity of the mobile phone (e.g. smallness of screen size, non-traditional input method etc) makes usability difficult and which in turn affects the users' perceived satisfaction of the m-banking interface, as usability and user satisfaction are associated. Usability is a central issue for mobile phone design, service and evaluation because users need to access various functionalities via limited user interfaces often while they are on the road (on the move). This usability issues in turn affect users' satisfaction of mobile banking applications. In this study, the perceived satisfaction of users of m-banking applications for three Nigerian banks were assessed and evaluated based on the demographics: age, gender, experience, and education. The study was necessitated due to the dearth of studies on the effects of demographic factors on m-banking usability and satisfaction. An online-based survey approach was used. The results indicate that these factors had significant effect on the perceived satisfaction of m-banking applications. There are significant demographic (age, gender, education, experience) differentials in the user perceived satisfaction on the usability of mobile banking application interfaces.

Keywords: M-banking, demographic differentials, perceived usability satisfaction.

I INTRODUCTION

Mobile banking (m-banking) is an aspect of mobile commerce and a natural evolution of electronic banking (Mohammadi, 2015). It is one of the recent mobile technological innovations that have added the element of mobility in bank service delivery to bank customers (Mohammadi, 2015). Although other banking channels like the automatic teller

machines (ATMs), Internet banking, and telephony together with the traditional banking channel provide effective delivery channels, they do not cater for bank users who are on the move. Therefore, m-banking offers users the opportunity to transact banking business anywhere and anytime while on the go (Shaikh & Karjaluo, 2015). Within the context of m-banking, users can do banking transactions while on the move or while doing other tasks at the same time. This channel of banking has some advantages and challenges. It avails bank users and customers, timely banking facilities like bill payment, account management, money transfer, monitoring and finding ATM locations, and information inquiry, etc (Afshan & Sharif, 2016). M-banking has greater convenience for bank customers as it makes traveling to and queuing at bank branches or ATM locations unnecessary (Afshan & Sharif, 2016). It benefits users in terms of time optimization, instant connectivity, immediate information, great interactivity, convenience, and ubiquity (Malaquias & Hwang, 2016). These have the potential of increasing customer satisfaction. With m-banking, users conduct banking transactions anyplace and anytime and they connect to banking services easily and quickly with mobile devices. Banking services are offered interactively and immediately (Gu et al., 2009). For banks, m-banking channel enhances service quality, decreases service cost, and enhances operational efficiency, therefore, it is not only attractive to customers, but it is also attractive to banks as well (Shaikh & Karjaluo, 2015; Afshan & Sharif, 2016).

M-banking has the potential of improving customers' quality of life and bringing efficiency to banks (Malaquias & Hwang, 2016). The improved service delivery and enhanced customer satisfaction brought about by m-banking helps in the retention of bank customers, attracting new ones and also enables the bank to maintain a competitive position in the market (Lee et al., 2015). In addition, this leads to increased market share, and profitability, reduced failure cost, price elasticity, lower business cost and cost of attracting new customers by the bank (Bayraktar et al., 2012). However, the context of m-banking implies that portable mobile devices like mobile phones, smart phones, tablets, and personal digital assistants (PDAs) are used as medium of transaction. Small portable (mobile) devices pose some

challenges and issues that can affect the usability and user satisfaction of m-banking users. Some of these issues and challenges are: mobile context, poor/limited connectivity, small screen size, limited processing capability, reduced display resolutions, high power consumption, limited input modalities (non-traditional input methods), and navigational difficulties, etc (Lee et al., 2015; Zhang & Adipat, 2005; Harrison et al., 2013). Also, the mobility of the m-banking user is a critical factor to the success or failure of the application (Harrison et al., 2013). These challenges can elicit users' emotional reaction and affect their task performance with respect to m-banking. As a result of these issues with mobile devices on which m-banking is anchored, many m-banking applications remain difficult to use. Mobile application usability is difficult because smart phones have small screens and the mechanism for input is tiny (Lee et al., 2015; Hoehle et al., 2016). Thus, it becomes necessary to assess the level of users' satisfaction in an m-banking usability context.

In this study a further attention is given to demographic factors such as age, experience, education, and gender to ascertain their effects on perceived satisfaction. Prior research posits that age, experience and education are factors influencing users' interaction with mobile banking in Nigeria (Agwu & Carter, 2014). Furthermore, Agwu and Carter (2014) stated that there is dearth of research in m-banking usability evaluation in Nigeria as existing research focused on Internet banking and mobile banking adoption rather than m-banking usability evaluation (Agwu & Carter, 2014). This study was necessitated due to the dearth of studies on the effects of demographic factors on m-banking usability and satisfaction.

A. M-Banking

M-banking is defined as "...an application of m-commerce that enables customers to access bank accounts through mobile devices to conduct transactions such as checking account status, transferring money, making payments, or selling stocks" (Shaikh & Karjaluo, 2015; Alafeef et al., 2012). It is an innovative communicative channel that allows customers to interact with a bank through a portable device (Masrek et al., 2012; Akturan & Tezcan, 2012). Banks offer four points of access to mobile banking services, as follows: 1) mobile applications that are downloadable to smart phones, 2) web application that can be used on any smart phone or mobile phone with a web browser, 3) applications that are downloadable to a tablet, 4) short messaging service (SMS) for account information notification (Shaikh & Karjaluo, 2015). Various terms are used to refer to mobile banking, such as, m-banking, cell phone banking,

branchless banking, m-payment, m-transfer, m-finance, and pocket banking (Shaikh & Karjaluo, 2015). M-banking is an easy, simple, fast, and secure banking alternative (Ravendran, 2013). Juniper Research (2013) reports that by 2017, more than one billion users are expected to use m-banking globally. This projection represents 15% of the mobile subscription base. Mobile phone subscription is about 96% of the world population (Shaikh & Karjaluo, 2015; International Telecommunication Union, 2011). In 2014 alone, more than 1.9 billion units of mobile devices were sold and smart phones account for more than 60% of mobile phone sales (Gartner Research, 2015). This statistics show the possibility of more mobile phone users being converted to mobile bank users in the near future. The increasing numbers of smart phones as well as the growing mobile web usage are very likely to drive users and consumers further towards m-banking option (Ravendran, 2013). However, the characteristics of mobile devices in terms of usability can impede the rate at which mobile phone users convert to m-banking users, but improvement in usability, especially satisfaction can influence and improve the conversion rate in the mobile context. This is true because satisfaction affects users' intention to use a system or application (Ravendran, 2013; Kargin et al., 2009).

B. M-Banking Usability and User Satisfaction

Usability, according to ISO 9241-11 standard (ISO, 1997), is "the level of effectiveness, efficiency, and user satisfaction when a given product is used to achieve a specific aim by a specific user in a specific usage situation". Effectiveness is defined by the standard as "accuracy and completeness with which users achieve their goals". Efficiency is "the resources expended in relation to the accuracy and completeness with which users achieve their goals" and user satisfaction is "freedom from discomfort and positive attitude towards the use of the product" (Ravendran, 2013). Usability is a software quality attribute and as ISO 13407 puts it, it is the extent to which a product can be used by the user to achieve specified goals (ISO, 1999). In IEEE standard (IEEE, 1990), usability is defined as the "ease with which a user can learn to operate, prepare input for, and interpret outputs of a system or component". According to ISO/IEC 9126-1 (Bevan, 2001), usability is "related with attributes of the product that make it understandable, learnable, easy to use, and attractive". Nielsen (1999) also described usability as ease of use and learning. Usability has two aspects, namely: perceived and performance usability. (For more on usability and user satisfaction, see Hussain et al., 2015; Hussain & Mkpojiogu, 2015a; 2015b; Hussain et al., 2016). Perceived usability (subjective usability) is the

usability of a system or application on the basis of users' perception or judgment (Reinecke & Beinstein, 2011). On the other hand, performance usability (actual or objective usability) is the usability of a system or application based on the performance of users on specific tasks in a real operational environment (Lew et al., 2010). Perceived usability of an interface is often more influential than that of performance usability (Ravendran, 2013; Phillips & Chapparo, 2009).

Banking efficiency, in particular, task efficiency, is central in the mobile context. In this context, users can fulfill their banking needs anytime and at any place through their mobile devices. M-banking beckons for a more efficient interaction. This need is echoed further by the challenges presented in the mobile context like smallness of screen size and the stronger focus on task completion in shorter time. It is needful to provide interface that is usable in the context of mobile banking that offers high productivity and performance. In like manner, mobile effectiveness is very crucial in m-banking applications. It is closely associated with the simplicity, ease of use and user friendliness of the interface of a mobile banking application. Complexity in m-banking interface is likely to hinder effectiveness, thus leading to poor usability (Ravendran, 2013; Yoon, 2010). Simplicity and interactivity (cognitive dimensions) are key antecedents of mobile phone usability. Simplicity is a major part of a highly usable interface. It makes a positive but indirect contribution to usability by influencing interactivity (Lee et al., 2015).

Satisfaction is a user's perception of the degree to which his/her expectations have been fulfilled (Ravendran, 2013; Yoon, 2010). It can also be defined as a mobile phone user's summary affective response (Lee et al., 2015). The more the user considers the usability experience with a mobile phone, the more the user is satisfied. There is a validated association between usability and satisfaction (Lee et al., 2015). Satisfied online banking users are more likely to purchase more products and services from their banks than unsatisfied users (Ravendran, 2013). This reaction is likely to be the same for m-banking users. Customer satisfaction is a significant determinant of m-banking loyalty. Satisfied customers return and buy more and they also tell others about their experiences. Strongly dissatisfied customers exit and leave while weakly satisfied customers may not leave but they complain (Bayraktar et al., 2012). Lee et al. (2015) posit that users' usability experience translates well into apps loyalty via satisfaction and trust. Customer dissatisfaction leads to negative word-of-mouth, disloyalty and distrust. A greater degree of satisfaction leads to a greater degree of

loyalty (Lee et al., 2015). Furthermore, visual design (design aesthetics, hedonic and visual appeal and attractiveness) of an application has the potential to spur emotional appeal and to ginger user satisfaction (Coursaris & van Osch, 2016). Efficiency and effectiveness of a system have effect on user satisfaction (Coursaris & van Osch, 2016). In addition, demographics such as age and experience have been determined from prior research as having impact on usability and user satisfaction (Kang & Yoon, 2008; Mayhorn et al., 2012; Page, 2014; Ghayas et al., 2013; Kurniawan, 2008).

In this paper, an assessment is made on the satisfaction of m-banking users based on their perceived usability of m-banking application interfaces using demographic characteristics as antecedents. The remaining part of this paper is organized as follows: section 2 deals with the methodology, section 3 presents the results and discussion, while section 4 concludes with the conclusion.

II METHODOLOGY

In this study, a survey approach was used to collect data and a sample of 150 online participants was selected purposely for the study. The selected participants were identified and recruited via Facebook and email. The participants are all mobile banking users in Nigeria. Three banks were selected for the study too. The selected participants are customers to one of the three banks and users of their respective mobile banking applications. The three banks include: GtBank, Skye Bank, and Diamond Bank. Online questionnaire was distributed to the selected respondents via Facebook and emails. The filled questionnaires were returned through the same channel. The study instrument was adapted from Abubakar et al. (2015).

The instrument was face validated. In addition, a construct validation was done and the instrument was psychometrically valid for the study as all items were loaded onto the construct "perceived satisfaction". The result of the factor analysis indicates that the variance of the principal component (construct, i.e. perceived satisfaction) that is explained by each item in the instrument ranged from 0.674 to 0.918. The Kaiser-Meyer-Olkin (KMO) measure of sampling adequacy is 0.962 (very close to 1), indicating that the correlation matrix of the instrument's items is adequate for the factor analysis. The Bartlett's test of sphericity is: approx. $\chi^2(595) = 15557.52$, $p=0.000$ (i.e. $p < 0.01$); this shows that the correlation matrix of items in the instrument is not an identity matrix, implying that the instrument has good construct validity.

Furthermore, a reliability analysis was carried out and the resulting Cronbach alpha coefficient was 0.986, indicating that there is good internal consistency of all items in the instrument. Cronbach alpha coefficients that are 0.70 and above are regarded as good estimates of reliability and internal consistency of survey instrument (Nunnally, 1973). The instrument consists of 37 items; however, two items were eliminated from the analysis due to their poor item reliability. The items in the instrument were measured using a 9-point likert-type scale. The items covered the satisfaction of users in the following areas: mobile device compatibility, learning ability, interface structure and layout, task structure and presentation, privacy and reliability, and overall user impression. The two items eliminated were from overall impression. The data from the filled and returned questionnaires were analyzed using SPSS Version 17 package. A one way ANOVA analysis was computed to ascertain the differentials in the perceived satisfaction of the three banks' application interfaces as well as the differentials in the perceived satisfaction based on some demographics like age, educational qualification, experience, and gender.

III RESULTS AND DISCUSSION

This section presents the results of analysis and discussion. The differences in the perceived satisfaction of mobile banking applications with respect to the apps used, age, gender, education and experience were analyzed and evaluated.

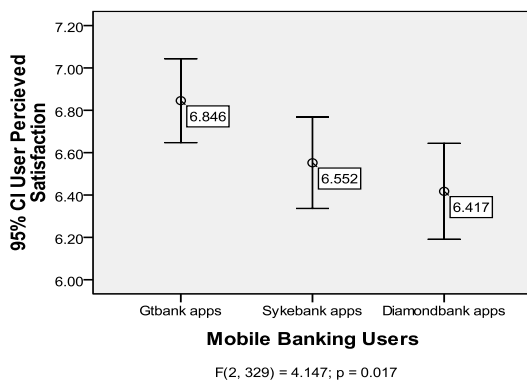

Figure 1. M-Banking Users' Perceived Satisfaction

The perceived satisfaction of m-banking users for the three banks is significantly different, $F(2, 329) = 4.147, p < 0.05$ (Figure 1). All users of the three bank apps are satisfied with their banks' m-banking application interface, however Gtbank users have the highest perceived satisfaction ($M=6.846, SD=1.28$), followed by Skye Bank users ($M=6.552, SD=1.05$). Diamond Bank users have the least perceived m-banking application satisfaction ($M=6.417, SD=0.98$). Further post hoc pair-wise comparison (using Bonferroni's type-1 error correction) reveals

that Gtbank and Diamond Bank pair are significantly different in their perceived user satisfaction ($p < 0.05$), all other pairs have the same level of perceived satisfaction. This result indicates the Diamond Bank m-banking apps user interface needs improvement to enhance users' perception of its usability and satisfaction.

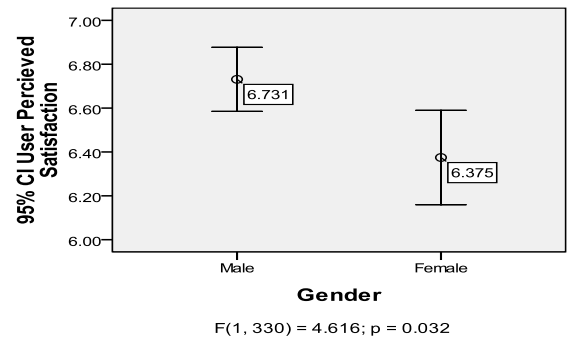

Figure 2. M-Banking Users' Perceived Satisfaction By Gender

The analysis reveals a significant gender differential in the perceived satisfaction of the m-banking applications, $F(1, 330) = 4.616, p < 0.05$ (Figure 2). The male users ($M=6.731, SD=1.22$) irrespective of their banks, have more perceived m-banking satisfaction than the females ($M=6.375, SD=0.83$). A further study is needed to ascertain why females are less satisfied than their male counterpart.

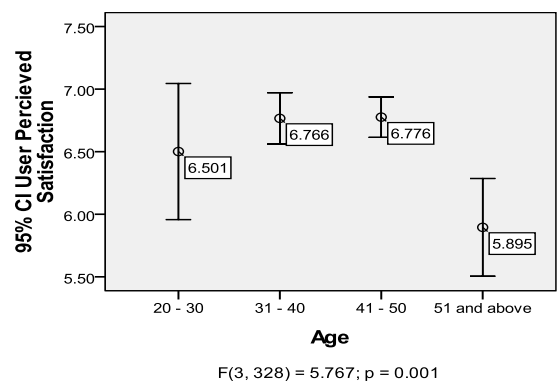

Figure 3. M-Banking Users' Perceived Satisfaction By Age

The one-way ANOVA shows an age-wise significant difference in m-banking perceived satisfaction, $F(3, 328) = 5.767, p < 0.01$ (Figure 3). There seems to be a quadratic trend in the level of users' perceived m-banking usability satisfaction as the users' satisfaction rises with age from age category 20-30 ($M=6.501, SD=1.29$) to age group 31-40 ($M=6.766, SD=1.30$) up to peak at age group 41-50 ($M=6.776, SD=0.89$) and fell afterwards at age group 51 and above ($M=5.895, SD=1.08$). However, irrespective of age, the users have certain levels of satisfaction, the older users (ages 51 and

above) have the least user satisfaction ($M=5.895$, $SD=1.08$). The middle aged users (ages 31-50) seem to be more enthusiastic and satisfied than all other age groupings (the younger, ages 20-30 and the elderly, ages 51 and above). Further post hoc analysis reveals that ages 51 and above and 31-40; ages 51 and above and 41-50 are those whose perceived satisfaction are significantly different, all other pairs have similar perceived usability satisfaction.

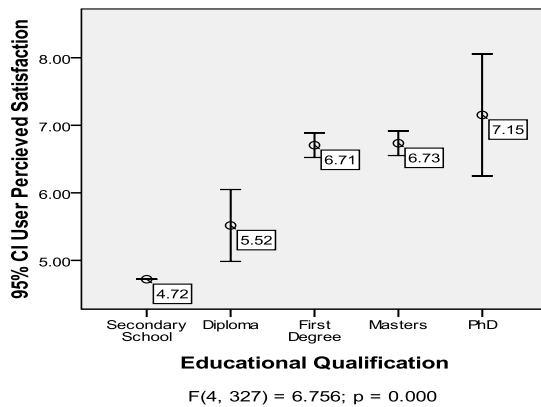

Figure 4. M-Banking Users' Perceived Satisfaction By Educational Qualification

As in the previous results, there is a significant difference in the m-banking users' perceived satisfaction based on their educational qualification, $F(4, 327) = 6.756$, $p < 0.01$ (Figure 4). Education has a strong influence the users' perceived satisfaction. There is an increasing trend in their average perception with higher educational qualification; secondary school ($M=4.73$, $SD=0.00$), diploma ($M=5.52$, $SD=0.84$), first degree ($M=6.71$, $SD=1.14$), masters ($M=6.73$, $SD=1.14$), and PhD ($M=7.15$, $SD=1.35$). The more the users are educated, the more they are satisfied with apps interfaces. However, there seems to be a near plateau experience for first degree and master's degree holders before a rise in the user satisfaction experience at PhD level. PhDs are the most satisfied with m-banking. A Bonferroni type-1 error correction pair-wise comparison indicate that the user satisfaction of secondary school and diploma users are significantly the same, in addition, the perceived satisfaction of graduates and post-graduates are also significantly similar after correcting for type-1 error.

The result indicates that there is a significant difference in the perceived satisfaction of m-banking users based on years of experience, $F(4, 327) = 5.618$, $p > 0.01$ (Figure 5). There is also a slight quadratic trend in the perceived satisfaction of m-banking users on the basis of experience with m-banking apps use. Users' satisfactions grow with experience (from 1-2 years [$M=6.114$, $SD=1.61$], to

3-4 years [$M=6.58$, $SD=1.04$], to 5-6 years [$M=6.912$, $SD=0.92$], to 7-8 years [$M=6.947$, $SD=0.92$], but after this peak experience, there is a decline at 9 and above years experience ($M=6.894$, $SD=1.25$). This shows there is diminishing return in perceived satisfaction with higher experience (at years 9 and above). Furthermore, there is some sort of plateau from 5-6 to 7-8 years of experience before the decline in perceived satisfaction. While correcting for type-1 error using Bonferroni's method, the following groupings of years of experience were found to have significant user satisfaction, 1-2 and 5-6, 1-2 and 7-8, 1-2 and 9 and above; all other pair-wise comparisons have significantly the same perceived m-banking application interface satisfaction.

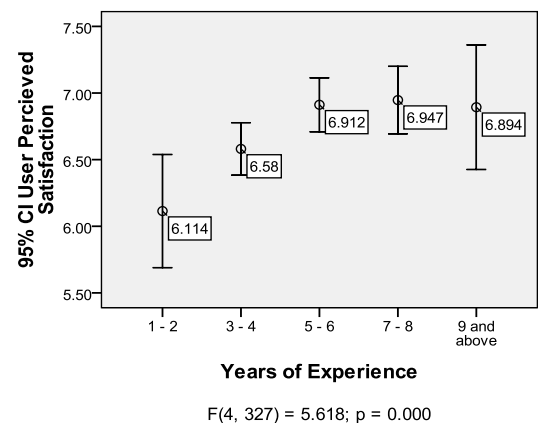

Figure 5. M-Banking Users' Perceived Satisfaction By Years Of Experience

IV CONCLUSIONS

Perceived satisfaction and usability on m-banking applications is interwoven as usable m-banking apps interfaces are satisfying interfaces and when users are satisfied with an interface, it is an indication of its usability. In this study, the user satisfaction of m-banking application users for three banks in Nigeria was assessed. 150 users using Gtbank, Skye Bank and Diamond Bank m-banking apps were conscripted into the study. Their perceived satisfaction based on the usability of the application interfaces was measured and evaluated. A one-way ANOVA was computed to determine the differences in the users perceived satisfaction on the basis of apps use and the social demographics such as age, gender, experience and educational qualification. The results reveal that there are significant differentials in the perceived satisfaction of mobile banking users based on the apps used, age, gender, experience and educational qualification. These factors had significant effect on the level of perceived user satisfaction of m-banking applications. These findings are helpful as it will assist in improving the m-banking apps interfaces of

the banks investigated so as to bridge the observed gaps and the perceived differences.

REFERENCES

- Abubakar, H.I., Hashim, N.L., & Hussain, A. (2015). A methodology for verification of a new model for evaluating the usability of an m-banking application, *International Journal of Mathematical Models and Methods in Applied Sciences*, 9.
- Afshan, S., & Sharif, A., (2016) Acceptance of mobile banking framework in Pakistan, *Telematics & Informatics*, 33, 370-387
- Agwu, M. E., & Carter, A. L. (2014). Mobile phone banking in Nigeria: benefits, problems and prospects. *International Journal of Business and Commerce*, 3(6), 50-70
- Akturan, U., & Tezcan, N. (2012). Mobile banking adoption of the youth market. *Marketing Intelligence & Planning*, 30(4), 444-459
- Alafeef, M., Singh, D., & Ahmed, K. (2012). The influence of demographic factors and user interface on mobile banking adoption: a review, *J. Appl. Sci.* 12(20), 2082-2095
- Bayraktar, E. Tatoglu, E., Turkyilmaz, A., Delen, D., & Zaim, S. (2012). Measuring the efficiency of customer satisfaction and loyalty for mobile phone brands with DEA. *Expert Systems with Applications*, 39, 99-106
- Bevan, N. (2001). International Standard for HCI and usability, *International Journal of Human Computer Studies*, 55, 533-552
- Coursaris, C.K., van Osch, W., A. (2016). Cognitive-affective model of perceived user satisfaction (CAMPUS): the complementary effects and interdependence of usability and aesthetics in IS design. *Information & Management*, 53, 252-264
- Gartner Research, *Worldwide mobile device sales in 2014* (2015)
- Gayas, S., Sulaiman, S., Jaafar, J., & Khan, M. (2013). Mobile Phones Icon Recognition: A comparative study with younger and older users. *Proceedings of the International Conference on Infocomm Technologies in Competitive Strategies (ICT)*, *Global Science and Technology Forum*, 10
- Gu, J.C., Lee, S.C., & Suh, Y.H. (2009). Determinants of behavioral intention to mobile banking. *Expert Systems with Applications*, 36, 11605-11616
- Harrison, R., Flood, D., & Duce, D. (2013). Usability of mobile applications: literature review and rationale for a new usability model, *Journal of Interaction Science*, 1 (1)
- Hoehle, H., Aljafari, R., & Venkatesh, V. (2016). Leveraging Microsoft's mobile usability guidelines: Conceptualizing and developing scales for mobile application usability. *Journal of Human Computer Studies* doi: <http://dx.doi.org/10.1016/j.jhcs.2016.02.001>
- Hussain, A., & Mkpojiogu, E.O.C. (2015a). The effect of responsive web design on the user experience with laptop and Smartphone devices, *Jurnal Teknologi (Sciences & Engineering)*, 77 (4), 41-47
- Hussain, A., & Mkpojiogu, E.O.C. (2015b). An application of ISO/IEC 25010 standard in the quality-in-use assessment of an online health awareness system, *Jurnal Teknologi (Sciences & Engineering)*, 77 (5), 9-13
- Hussain, A., Mkpojiogu, E.O.C. & Hassan, N.F.A. (2016). Systematic review of mobile learning applications for children. 2nd *International Conference on Information and Communication Technology for Transformation (IC-ICT4T'16)*, Kota Kinabalu, Malaysia, 5-7 April.
- Hussain, A., Mkpojiogu, E.O.C., & Hussain, Z. (2015). Usability evaluation of a web-based health awareness portal on Smartphone devices using ISO 9241-11 model. *Jurnal Teknologi (Sciences & Engineering)*. 77 (4), 1-5
- IEEE. (1990). IEEE standard computing dictionary: a compilation of IEEE standard computer glossaries, New York: Institute of Electrical and Electronics Engineers.
- International Telecommunication Union, *ICT facts and figures: the world in 2011* (2011). <http://www.itu.int/ITU-D/ict/fact/2011/material/ICTFactsFigures2011.pdf>
- ISO (1999). ISO 13407: *International Standard, Human-Centered Design Processes for Interactive Systems*. Geneva, Switzerland: International Organization for Standardization
- ISO (1997). ISO 9241: Ergonomics requirements for office work with visual display terminals (VDTs). Geneva, Switzerland: International Organization for Standardization
- Juniper Research, *Mobile banking handset and tablet market strategies 2013-2017*, (2013) http://www.juniperresearch.com/reports/mobile_banking
- Kang, N. E., & Yoon, W. C. (2008). Age-and experience-related user behavior differences in the use of complicated Electronic devices, *International Journal of Human-Computer Studies*, 66(6), 425-437
- Kargin, B., Basoglu, N., & Daim, T. (2009). Factors affecting the adoption of mobile services, *International Journal of Services Sciences*, 2 (1), 29-52
- Zhang, D., & Adipat, B. (2005). Challenges, methodologies, and issues in the usability testing of mobile applications, *International Journal of Human-Computer Interaction*, 18 (3) 293-308
- Kurniawan, S. (2008). Older people and mobile phones: A multi-method investigation. *International Journal of Human-Computer Studies*, 66(12), 889-901
- Lee, D., Moon, J., Kim, Y.J., & Yi, M.Y. (2015). Antecedents and consequences of mobile phone usability: linking simplicity and interactivity to satisfaction, trust, and brand loyalty, *Information & Management*, 52, 295-304
- Lew, P., Olsina, L., & Zhang, L. (2010). Quality, quality-in-use, actual use, and user experience as key drivers for web application evaluation
- Malaquias, R.F., & Hwang, Y. (2016). An empirical study on trust in mobile banking: a developing country perspective, *Computers in Human Behavior*, 54, 453-461
- Masrek, M.N., Omar, N., Uzir, N.A., & Khairuddin, I.E. (2012). The impact of technology trust on mobile banking utilization, *Sci. Ser. Data Rep.* 4 (12) 27-36
- Mayhorn, C. B., Lanzolla, V. R., Wogalter, M. S., & Watson, A. M., (2012). Personal digital assistants (PDAs) as medication reminding tools: Exploring age differences in usability. *Gerontechnology*, 4(3), 128-140
- Mohammadi, H. (2015). A study of mobile banking loyalty in Iran, *Computers in Human Behavior*, 44, 35-47
- Nielsen, J.N. (1999). *Designing web usability: the practice of simplicity*, 1st Edition, Berkeley, CA: Peachpit Press.
- Nunnally, J. (1973). *Psychometric Theory*, New York: McGraw-Hill
- Page, T. (2014). Touchscreen mobile devices and older adults: a usability study. *International Journal of Human Factors And Ergonomics*, 3(1), 65-85
- Phillips, C., & Chapparo, C. (2009). Visual appeal vs usability: which one influences user perceptions of a website more? *Usability News*, 11 (2), 1-9
- Ravendran, R. (2013). *Improving usability of e-commerce websites via tag-based customization: a study of online and mobile banking*. A PhD Thesis, Faculty of Electrical Engineering and Computer Science, Queensland University of Technology.
- Reinecke, K., & Beinstein, A. (2011). Improving performance, perceived usability, and aesthetics with cultural adaptive user interfaces, *ACM Transaction in Computer-Human Interaction*, 18 (2), 1-29
- Shaikh, A.A., & Karjaluoto, H. (2015). Mobile banking adoption: a literature review, *Telematics & Informatics*, 32, 129-142
- Yoon, C. (2010). Antecedents of customer satisfaction with online banking in China: the effects of experience, *Computers in Human Behavior*. doi: 10.1016/j.chb.2010.04.001

Knowledge Utilization and Decision Making in Construction Projects in Malaysia

Ali Mohammed Alashwal, and Ng Wen Si

University of Malaya, Malaysia, (alialashwal@um.edu.my, n.w_si@hotmail.com)

ABSTRACT

Knowledge utilization is the process to apply right and relevant knowledge at the right time and place for effective decision making. The purpose of this paper is twofold. First, to identify the characteristics of knowledge utilization in construction projects in Malaysia. Second, to test whether there is an influence of knowledge utilization on decision making. A questionnaire survey was used to collect data from 124 professionals in different types of construction projects. Processes, factors, and obstacles of knowledge utilization were identified and discussed in this paper. However, the results indicated that there is no significant relationship between knowledge utilization and effectiveness of decision making.

Keywords: knowledge conversion, knowledge sharing, decision making, Malaysia.

I INTRODUCTION

The construction industry is a knowledge-based industry. Construction projects are expensive, complex and large custom-built facilities, which strongly rely on knowledge input (Ly, Anumba, & Carrillo, 2005). Knowledge is an important asset to construction companies, which are project-based organization, and knowledge management has gain more attention in this industry (Owira & Ogollah, 2014). However, knowledge has no value unless it is being utilized. Knowledge utilization is an integral activity of knowledge management. All the activities of knowledge management are created to get benefits from the positive effect of knowledge on the organization's performance (Bloodgood, 2009).

Construction projects have become more complex due to change in clients demand such as more quality and value for money and environment regulations. In addition, fragmentation of the construction industry caused lower project efficiency leading to client dissatisfaction and low profitability (Charles, John, & Mike, 1999; Patricia, Chimay, & John, 2000). Besides, the construction industry is complex and large and many players do not share common education base (Asmi, Rasli,

Majid, & Rahman, 2009). Professionals tend to forget the knowledge and experience for specific projects once the project is completed and they usually repeat the same mistakes (Kanapeckiene, Kaklauskas, Zavadskas, & Seniut, 2010). This situation can be regarded as 'knowledge wastage'. Knowledge and lessons learned from previous projects need to reapply to generate new knowledge so that can improve projects performance and increase competitiveness (Vines et al., 2004). Construction projects are highly depending on knowledge capacities of stakeholders and not all these knowledge capacities are utilized because sometimes knowledge is not applied appropriately. Therefore, lack of utilization of knowledge can increase uncertainty in construction projects.

Similar to knowledge management, knowledge utilization has a positive impact on project output such as project performance (Alashwal, Abdul-Rahman, & Radzi, 2016). By definition, knowledge utilization involves the application of knowledge for effective decision making. Since there is a limited number of studies in this area, the purpose of this paper is identify the characteristics of knowledge utilization and determine its influence on decision making processes in construction projects.

Decision making is defined as a process to diminish uncertainty to a considerable level and determine alternatives to suit a purpose by selecting the best option (Ahmed & Omotunde, 2012). The process of decision making takes place in many stages in construction project (Castillo, Al-jibouri, & Halman, 2010). Alsendi (2015) affirmed that slow decision making can cause delay of construction projects. Delay can become the potential risks to cause time and cost overrun, arbitration, dispute, total abandonment and litigation in construction projects (Aibinu & Jagboro, 2002; Sambasivan & Soon, 2007). Hence, effective decision making is important to successfully completing construction projects as it will influence the performance of work.

The following section provides a review of available literature on knowledge utilization to identify its processes, factors, and obstacles. The

section also highlights the relationship between knowledge utilization and decision making. The section after that explains the method of collecting and analyzing the data to verify knowledge utilization characteristics and its influence on decision making.

II KNOWLEDGE UTILIZATION CHARACTERISTICS

A. Processes of Knowledge Utilization

There are seven processes of knowledge utilization proposed by (Alashwal, Abdul-Rahman, & Radzi, 2014; Alashwal et al., 2016) which are knowledge acquisition, knowledge conversion, knowledge sharing, knowledge generation, knowledge integration, knowledge competence, and knowledge utilization.

Fong and Choi (2009) highlighted that knowledge can be acquired internally and externally in construction projects. When knowledge is successfully acquired and shared among each other in a particular approaches only mean that the knowledge is being utilized (Liebowitz & Megbolugbe, 2003). Knowledge can be acquired using organization resources and then stored for usage when needed.

Knowledge conversion is the process to convert knowledge into organizational mean (Lee & Suh, 2003). The main process to convert knowledge is through applying and sharing knowledge that has been stored (Ping & Cheng, 2004). Knowledge can be generated as a result of knowledge conversion (Alashwal et al., 2014). In projects, team members can interact and communicate to generate new or emergent knowledge (Fong, 2003). Before utilizing knowledge, it is required to integrate knowledge through combining knowledge that was shared by socialization process (Radzi, 2012). During these processes, competence plays an important role especially in problem solving and decision making process (Charoenngam & Maqsood, 2001). According to Spencer, McClelland, and Spencer (2011), competence is the simultaneous integration of skills, attitudes and knowledge needed in performance of designated role.

The last process is knowledge utilization, which can be considered as one of the critical process in the creation of knowledge. Knowledge utilization can enhance the performance of project if the knowledge which is successfully converted is applied or utilized (Alashwal et al., 2014). For example, site managers may use tacit knowledge to improve site management by utilizing the lesson

learned from past experiences and solutions in construction projects (Fikri & Anumba, 2006).

B. Factors Influencing Knowledge Utilization

Koskinen (2003) divided the factors influencing the generation and utilization of tacit knowledge in project environment into internal and external factors. The internal factors are under control of an individual that can be categorised into three distinct groups, which are communication, memory and motivational systems. While external factors which also called the situational system include leadership style and culture of organization (Koskinen, 2003). While, Pathirage, Amaratunga, and Haigh (2008) grouped the obstacles into three different levels which are Individual level: Intra-personal drivers; Group level: Inter-personal drivers; and Organizational level: Situational drivers.

Other factors influence knowledge utilization, based on case study findings include competence of team members, pressure to complete the project on time, and teamwork (Alashwal et al., 2016; Radzi, 2012). These three factors influence the speed of knowledge utilization when managing time-related issue during construction phase.

C. Obstacles of Knowledge Utilization Process

In their study, Tervonen and Ojanen (2015) identified obstacles of knowledge utilization in six stages of knowledge utilization process as described by Verkasolo and Lappalainen (1998). Obstacles of sustainability of knowledge utilization can be categorizes into four levels. Firstly, the organizational factors, which influence the sustainability of knowledge utilization. Examples of organizational factors are attitudes, level of competence, and internal development. Secondly, sustainability of knowledge utilization needs methods and tools to collect and evaluate information to make effective practice of knowledge management. Thirdly, the need for assessment activity, which is related to measurement of sustainability of knowledge utilization. Lastly, the need to monitor environment of business, stakeholders, and change management.

D. Influence of Knowledge Utilization on Decision Making

Construction projects are characterized by high levels of uncertainty and complexity. Project managers in construction projects have to undertake timely and immediate response in decision making as construction projects in recent times have become more complicated and dynamic. Knowledge is a significant asset that influence

decision making in an organization (Carrillo, 2004; Teerajetgul & Charoenngam, 2006). According to Hertwig and Hoffrage (2012), “knowledge is crucial to an individual’s decision making performance.”

Effectiveness of decision making can be measured using four dimensions namely quality of decision making, speed of the decision, yield of decision where an organization makes decisions faster than competitors and translates decisions into actions and lastly appropriate amount of effort devote by decision makers (Blenko & Mankins, 2012).

Decision making in construction projects can be challenging and complicated as it is one of the knowledge intensive activity. Professionals in construction projects must understand how to apply, manage and utilize the valuable knowledge when making decision as every individuals owned different knowledge-based and they might have different experiences therefore can lead to different decision making (Teerajetgul & Charoenngam, 2006). In addition, it is important for professionals working in construction projects to fully utilize all available knowledge resources in decision making process. Thus, it can be assumed that knowledge utilization can positively influence decision making. This proposition will be tested empirically as shown in the following section.

III METHODOLOGY

A questionnaire survey was chosen as research method for this study to identify processes, factors and obstacles of knowledge utilization and the influence of knowledge utilization on effectiveness of decision making in construction projects in Malaysia. Respondents were required to rate the listed statements in the survey based on 5-point Likert scale representing processes, obstacles and factors of knowledge utilization and effectiveness of decision making in their projects.

Based on the “Construction Quarterly Statistical Bulletin” published by the Construction Industry Development Board on September 2015, a sample size of about 187 construction projects was calculated based on the population of projects under construction. The total number of construction projects was 3910. Thus, 190 sets of questionnaires were prepared and distributed. Whereas 100 questionnaire forms were distributed randomly through face-to-face manner, other 90 questionnaire forms were sent online to target respondents randomly via email. The target respondents were professionals that have experience in construction projects and are working in construction companies

in Klang Valley and Selangor States. The 100 set of questionnaires, which was distributed face-to-face, was fully answered. However, only 24 sets of questionnaire were answered through the email. The total response was 124, making 65.26% response rate, which is in general good. The result of Cronbach’s Alpha showed that this questionnaire is reliable ($\alpha = 0.79$).

IV FINDINGS AND DISCUSSION

A. Processes of Knowledge Utilization Developed by Local Construction Professionals

Table 1 shows the ranking of knowledge utilization processes. The following paragraphs discuss the top-five ranked processes.

Table 1. Ranking of Knowledge Utilization Processes

Statement	Mean	SD	Ranking
We apply and reuse knowledge, lesson learned, best practices and expertise at the right time to solve problems in construction projects	4.64	0.50	1
We keep acquired information in database or documents for future reference	4.44	0.64	2
We validate the acquired information before using it	4.23	0.63	3
We share relevant data, information and knowledge from lesson learned with others within our organization	4.22	0.68	4
We acquire relevant data and information from internal and external resources	4.21	0.60	5
We create and use new knowledge to resolve issues or problems in construction projects	4.15	0.71	6
We create new knowledge through interaction and communication with other team members	4.09	0.66	7
We convert relevant information (internal or external) to suit our project or company	4.06	0.63	8
We use external knowledge to resolve problems or making decision in construction projects	4.05	0.64	9

The respondents who agreed to the statement “we apply and reuse knowledge, lesson learned, best practices and expertise at the right time to solve problems in construction projects” are exposed to the process of **knowledge utilization** in construction projects. Majority of the respondents agreed that utilization of knowledge is the most important process which allows them to reuse the knowledge accumulated from the past practices and experiences. Past knowledge is directly applied for

useful project output such as solving problems related to current projects.

The statement “*we keep acquired information in database or documents for future reference*” indicated that professionals in local construction industry have practiced **knowledge storage and retrieval** as their current practice in construction projects. It seems that many companies have their own database to keep the useful data and information for future usage.

In addition, the statement “*we validate the acquired information before using it*” that agreed by majority revealed that **knowledge validation** is one of the process of knowledge utilization practiced in local projects. Practitioners need to check the information first before applying and utilizing the information in construction projects to ensure accuracy and suitability of the information.

Moreover, the statement “*we share relevant data, information and knowledge from lesson learned with others within our organization*” indicated that **knowledge sharing** is one of the important processes of knowledge utilization. This indicates that professionals in construction industry are willing to help each other within a company by sharing relevant knowledge and utilize the relevant knowledge in construction projects.

Lastly, the statement “*we acquire relevant data and information from internal and external resources*” represents **knowledge acquisition** as one of the vital processes of knowledge utilization. According to Ping and Cheng (2004), knowledge acquisition is the process of collecting data, information and knowledge that is vital and useful for the projects and organizations which from internal sources and external sources. Respondents need to acquire relevant information from different sources in order to fully utilize relevant data and information that are useful to problem solving in construction projects.

B. Factors Affecting Knowledge Utilization

The top five factors that influence knowledge utilization as rated by the respondents are “*experience of individuals in construction projects*”, “*competence of professionals*”, “*interactions between team members (face-to-face meeting)*”, “*teamwork*”, and “*leadership*”.

Based on the data analysis, experience of individuals in construction projects is a significant factor that affects the knowledge utilization in construction projects. This result is supported by Chaminda, Dilanthi, and Richard (2007), who

affirmed that construction industry is more centered on experience of construction workers and professionals. Knowledge utilization can be achieved by interaction between team members to share their knowledge and experience.

Based on the research findings of Radzi (2012), competence and teamwork are interrelated with each other as the factors to affect the knowledge utilization and competence is depends on level of teamwork. The result of this study is in line with these findings. The capability and skills of construction project professionals are very significant in affecting knowledge utilization in order to solve problems or make decisions. Furthermore, co-operation between project members is important in which competent employees will share their experience or knowledge they learnt before with others.

Lastly, many respondents chosen leadership as factor of knowledge utilization as they might think that leadership can be positive encouragement and influence from upper level of management thus can create an open environment for team members to generate and utilize knowledge. This finding is also similar to the finding of Radzi (2012).

C. Obstacles of Knowledge Utilization

Majority of the respondents agreed on these obstacles of knowledge utilization “*understand the information, compare and link the information from various databases*”, “*level of understanding of knowledge utilization among team members*”, “*attitudes of team members*”, “*availability of time to acquire, validate, convert, share, and apply knowledge*” and “*determine the knowledge in process of acquiring knowledge*”. These five obstacles are the top rated factors of knowledge utilization in Malaysian construction projects.

The statement “*understand the information, compare and link the information from various databases*” was highly rated by respondents. This may due to it is time consuming to understand, compare, and relate all relevant information that needed in carrying out tasks in construction projects from different databases. Thus, respondents feel that it is the significant challenges in knowledge utilization. The “*level of understanding of knowledge utilization among team members*” is the second highest ranking obstacle as the understanding of knowledge utilization is a challenging process.

Tervonen and Ojanen (2015) highlighted that attitudes, availability of time, and determining knowledge in the process of knowledge acquisition

are obstacles of sustainability of utilizing knowledge. The results of this paper indicated some of these obstacles. Construction professional regarded the availability of time and attitudes of project members on knowledge utilizing as important considerations. Professionals were always rushing to complete the tasks and achieve project goals or objectives within limited time. As knowledge utilization requires different processes including knowledge acquisition, validation, conversion, sharing, and applying, thus, the availability of time to undertake these processes is vital.

D. Influence of Knowledge Utilization Processes on Decision Making

Majority of respondents agreed on this two statements “*we perform quality decision making that enables achieving project goals and objectives*” and “*we make sure the outcomes of decisions are precise and consistent to attain project’s objectives*”. These two statements obtained high mean values may be because of they focus on achieving project goals and objectives instead of focusing on speed and time of doing decision. Construction projects are complex and involve many uncertainties, thus professionals might spend more time on planning before doing decision in order to achieve project goals or objectives. Then, they might more focus and concentrate on the project goals and objectives instead of speed, time, and effort of doing decision. In addition, regarding to Flueler (2007), the decision making can be considered as good if the decision is purposeful and meet the goals set in advance in the process of decision making.

In addition to this result, correlation test was conducted to determine if there is an association between knowledge utilization and decision making. Knowledge utilization (KU) represents the computed mean of knowledge utilization processes that comprised of nine variables as shown in Table 1. Effectiveness of decision making (DM) was also computed using the mean of four variables, namely “*we perform quality decision making that enables achieving project goals and objectives*”, “*we perform quality decision making that require less effort and time*”, “*we focus on speed of doing decision in limited time*”, and “*we make sure the outcomes of decisions are precise and consistent to attain project’s objectives*”.

Table 2. Result of Correlation between Knowledge Utilization (KU) and Decision Making (DM)

		KU	DM
KU	Pearson Correlation	1	0.11
	Sig. (2-tailed)		0.22
DM	Pearson Correlation	0.11	1
	Sig. (2-tailed)	0.22	

Referring to the results shown in Table 2, the correlation between KU and DM is only 0.11 with a p-value of 0.22. This indicates that the processes of knowledge utilization do not correlate with effectiveness of decision making in construction projects. This is perhaps related to the limitation of knowledge utilization practice in construction projects. Professionals in construction projects may have inconsistent practice of knowledge utilization in decision making. Furthermore, some of the companies might not implement decision support or knowledge management systems with completed sets of tools and technologies to support knowledge utilization in decision making.

Knowledge management provides the decision makers with useful tool while let them understand and apply the available knowledge at their own advantage in organization (Moss, 1999). The availability and appropriate usage of technologies and tools in managing knowledge would help decision makers in improving the efficiency of knowledge utilization. In addition, decision making is not established on the capability to manage knowledge (Janis & Mann, 1977; MacCrimmon, 1968; Simon, 1960). The skills and capabilities of professionals that involved in construction projects in facilitating and utilizing knowledge might affect the effectiveness of decision making.

V CONCLUSION

This paper highlights the important elements in knowledge utilization and the relationship between knowledge utilization and effectiveness of decision making in construction projects. The results of this research can be used as a guideline and reference for Malaysian practitioners in local construction industry to fully utilize their knowledge and experiences on construction projects. It might can raise and increase awareness of practitioners towards the important of knowledge utilization by understanding the whole framework of knowledge utilization and its influence on effectiveness of decision making in construction projects. It is recommended that future research can be conducted to determine other factors that influence the

effectiveness of decision making other than knowledge utilization.

REFERENCES

- Ahmed, M. T., & Omotunde, H. (2012). Theories And Strategies of Good Decision Making. *International Journal of Technology Enhancements and Emerging Engineering Research*, 1(10), 51-54.
- Aibinu, A., & Jagboro, G. (2002). The effects of construction delays on project delivery in Nigerian construction industry. *International journal of project management*, 20(8), 593-599.
- Alashwal, A. M., Abdul-Rahman, H., & Radzi, J. (2014). *Knowledge Utilization in Construction Projects: A Conceptual Framework*. Paper presented at the Knowledge Management International Conference (KMICe).
- Alashwal, A. M., Abdul-Rahman, H., & Radzi, J. (2016). Knowledge Utilization Process in Highway Construction Projects. *Journal of Management in Engineering*, 05016006.
- Alsendi, M. A. Y. (2015). *Studying the effect of decision making on delayed construction projects*. (Degree of Master of Engineering Management), The George Washington University, Manama, Kingdom of Bahrain.
- Asmi, A., Rasli, A., Majid, M. Z. A., & Rahman, I. A. (2009). Malaysian Practitioner's Perception on Knowledge Management in Construction Consulting Companies. *Modern Applied Science*, 3(7).
- Blenko, M. W., & Mankins, M. C. (2012). Decision Insights. *Measuring decision effectiveness*.
- Bloodgood, J. M. (2009). Organizational routines as mechanisms for knowledge creation, utilization, and storage. *Knowledge Management and Organizational Learning* (pp. 41-58): Springer.
- Carrillo, (2004). Managing knowledge: lessons from the oil and gas sector. *Construction Management and Economics*, 22(6), 631-642. doi: 10.1080/0144619042000226289
- Castillo, J. E. A., Al-jibouri, S. H. S., & Halman, J. I. M. (2010). *Risk-based decision making in construction: a case of planning and risk assessment of construction alternatives*. Paper presented at the Proceedings of the International Conference on Computing in Civil and Building Engineering, Nottingham University Press.
- Chaminda, P. P., Dilanthi, G. A., & Richard, P. H. (2007). Tacit knowledge and organisational performance: construction industry perspective. *Journal of knowledge management*, 11(1), 115-126. doi: 10.1108/13673270710728277
- Charles, E., John, S., & Mike, B. (1999). *Learning from knowledge management and trans-organisational innovations in diverse project management environments*.
- Charoengam, C., & Maqsood, T. (2001). *A qualitative approach in problem solving process tracing of construction site engineers*. Paper presented at the Proceeding of the ARCOM Seventh Annual Conference.
- Fikri, M. S., & Anumba, C. J. (2006). Potential for improving site management practices through knowledge management. *Construction innovation*, 6(4), 232-249.
- Flueller, T. (2007). Quality of Decision-making Processes. *Decision-making processes in radioactive waste governance-Insights and Recommendations*.
- Fong, P. S. W. (2003). Knowledge creation in multidisciplinary project teams: an empirical study of the processes and their dynamic interrelationships. *International journal of project management*, 21(7), 479-486. doi: http://dx.doi.org/10.1016/S0263-7863(03)00047-4
- Fong, P. S. W., & Choi, S. K. Y. (2009). The processes of knowledge management in professional services firms in the construction industry: a critical assessment of both theory and practice. *Journal of knowledge management*, 13(2), 110-126. doi:10.1108/13673270910942736
- Hertwig, R., & Hoffrage, U. (2012). *Simple heuristics in a social world*: Oxford University Press.
- Janis, I. L., & Mann, L. (1977). *Decision making: A psychological analysis of conflict, choice, and commitment*: Free Press.
- Kanapeckiene, L., Kaklauskas, A., Zavadskas, E. K., & Seniut, M. (2010). Integrated knowledge management model and system for construction projects. *Engineering Applications of Artificial Intelligence*, 23(7), 1200-1215. doi: http://dx.doi.org/10.1016/j.engappai.2010.01.030
- Koskinen, K. U. (2003). Evaluation of tacit knowledge utilization in work units. *Journal of knowledge management*, 7(5), 67-81. doi: 10.1108/13673270310505395
- Lee, H. S., & Suh, Y. H. (2003). Knowledge conversion with information technology of Korean companies. *Business Process Management Journal*, 9(3), 317-336. doi: 10.1108/14637150310477911
- Liebowitz, J., & Megbolugbe, I. (2003). A set of frameworks to aid the project manager in conceptualizing and implementing knowledge management initiatives. *International journal of project management*, 21(3), 189-198.
- Ly, E., Anumba, C. J., & Carrillo, P. M. (2005). *Knowledge management practices of construction project managers*. Paper presented at the 21st Annual ARCOM Conference, Khosrowshahi.
- MacCrimmon, K. R. (1968). [The Structure of Human Decisions., David W. Miller, Martin K. Starr]. *Administrative Science Quarterly*, 13(1), 186-189. doi: 10.2307/2391271
- Moss, T. (1999). Management forecast: optimizing the use of organizational and individual knowledge. *Journal of nursing administration*, 29(1), 57-62.
- Owira, J. A., & Ogollah, K. (2014). The Role of Knowledge Management Enablers in Successful Projects: Case of Construction Industry in Kenya. *European Journal of Business Management*, 1(11), 318-336.
- Pathirage, C., Amaratunga, D., & Haigh, R. (2008). *Tacit Knowledge Generation and Utilisation in the Construction Industry: from Process Perspective*. Paper presented at the Proceedings of the RICS Construction and Building Research Conference (COBRA 2008).
- Patricia, C., Chimay, A., & John, K. (2000). Knowledge management strategy for construction: key IT and contextual issues. *Proceedings of CIT, 2000*, 28-30.
- Ping, T. H., & Cheng, L. Y. (2004). Developing an activity-based knowledge management system for contractors. *Automation in Construction*, 13(6), 781-802.
- Radzi, J. B. (2012). *The Significance of Knowledge Utilization on Project Schedule: A Multi-Case Study*. Faculty of Built Environment. University of Malaya, Kuala Lumpur.
- Sambasivan, M., & Soon, Y. W. (2007). Causes and effects of delays in Malaysian construction industry. *International journal of project management*, 25(5), 517-526.
- Simon, H. A. (1960). The new science of management decision.
- Spencer, L. M., McClelland, D. C., & Spencer, S. M. (2011). *Competency assessment methods: history and state of the art*. University of Michigan: Hay/McBer Research Press.
- Teerajetgul, W., & Charoengam, C. (2006). Factors inducing knowledge creation: empirical evidence from Thai construction projects. *Engineering, Construction and Architectural Management*, 13(6), 584-599.
- Tervonen, N., & Ojanen, V. (2015, 2-6 Aug. 2015). *Sustainability knowledge utilization: challenges from internal and external perspectives*. Paper presented at the Management of Engineering and Technology (PICMET), 2015 Portland International Conference on.
- Verkasolo, M., & Lappalainen, P. (1998). A method of measuring the efficiency of the knowledge utilization process. *Engineering Management, IEEE Transactions on*, 45(4), 414-423.
- Vines, M., Hari, S., Olomolaiye, A., Liyanage, C., Lee, C., Kurul, E., & Egbu, C. (2004). *Lessons learned from knowledge management research: UK construction industry perspective*. Paper presented at the 4th International Postgraduate Research Conference, April 1st-2nd 2004.

Critical Factors in Developing Knowledge Management Systems

Sanath Sukumaran¹, S.M.F.D. Syed Mustapha², and Kanchana Chandran³

¹Taylor's University, Malaysia, sanath.sukumaran@taylors.edu.my

²Taif University, Saudi Arabia, syed.malek@tu.edu.sa

³Sunway University, Malaysia, kanchanac@sunway.edu.my

ABSTRACT

Over the past several years, we have seen many articles, research and survey findings highlighting the failures in Knowledge Management (KM) implementation in general and KM Systems (KMS) in particular. Clearly, there is a need to examine the state of KM from a broader perspective to determine the viability of prevailing KM frameworks and if the need for a new approach is required. This paper was inspired by the recent findings in the KM Survey 2016 published by Knowledge Management Professional Society (KMPro) on the critical factors contributing to organisational KM success and failures. The authors of this paper revisited the survey findings of KMPro to determine whether the critical success factors do indeed lead to a successful Knowledge Management System. The outcome of this paper is a conceptual framework and a catalogue of KMS functionalities deemed "critical" to boost the success rate of KM Systems in the future.

Keywords: Knowledge Management (KM), Knowledge Management Systems (KMS), Activity Theory (AT), Tacit Knowledge.

I BACKGROUND

This conceptual paper is based on the recent survey findings by KMPro (Knowledge Management Professional Society, 2016) spanning 1,576 organisations in nearly 60 countries. The study which was commissioned in 2015 involved the corporate, governmental and military sectors, in which "Five Primary Critical Factors Contributing to Organisational Knowledge Management Successes & Failures" were identified. The study is believed to be the most comprehensive study of Knowledge Management implementation ever conducted to date.

The primary purpose of the KMPro study was to determine the effectiveness of KM implementation within a broad range of organisational types, and to then attempt to identify any significant factors that impacted both successes and failures during the implementation.

The FIVE (5) critical success factors as espoused by KMPro in the aforementioned survey are discussed as follows:

KM Strategy: This is essential for effective and successful KM implementation. Provides policies and guidance towards a strategic and structured KM implementation to realise organisational goals. KM strategy must therefore have strong ties to the organisational strategy (Knoco, 2011). Mainstream KM systems tasked to manage KM in an organisation are somewhat separated from everyday organisational work practices and business processes resulting in loss of context rendering knowledge contributed defunct and redundant. Most knowledge workers therefore do not see KM efforts as an integral and significant aspect of their work. Therefore, it is important that KMS in the future no longer operate in silos like its counterparts of yesteryears. This calls for a KM Strategy in place.

KM Measurement: This is required to determine the impact of KM activities. It aims to provide useful metrics and/or statistics as to how knowledge is created, disseminated and leveraged for organisational gain. These measures drive and guide KM effort. Organisations today generally do not sufficiently recognize knowledge contributions because the conceptualization and measurement of knowledge capital as a primary organisational asset remains rudimentary. Hence, without a realistic and robust measure of knowledge capital built within an existing KM system, organisations will continue to revert to economic capital (status quo) instead of viewing KMS as a means to generate knowledge capital.

KM Tools: This refers to the extent to which technology may be used as an enabler to enhance and improve upon an organisation's KM initiatives. KM tools alone cannot guarantee that KM will succeed. KM tools can only be used where appropriate, given the overall KM strategy of the organisation.

Leadership Support: Refers to the extent to which there is support from senior leaders for KM initiatives to thrive. Conversely, leaders who do not "walk the talk" by providing support have resulted in KM initiatives becoming a "white elephant" leading to KM implementation failures.

Organisational Culture: Refers to the extent to which the organisation has embraced the right culture to facilitate KM activities. It also includes having an

appropriate reward and recognition system in place to promote a “healthy” KM environment.

It is important to note that the findings from the 2016 survey published by KMPro is aimed at understanding critical factors contributing to successes and failures of KM implementation in general but not specifically to KMS. Hence, taking into account the critical success factors outlined above in Section I, the research was set out to understand to what extent can the same critical success factors be used as means to guide KMS development efforts and to propose a conceptual framework to achieve the same.

II LITERATURE REVIEW

The literature was examined in relation to the objectives of the research namely, the role of KMS and importance of tacit knowledge elicitation using Activity Theory (AT).

A. Knowledge Management Systems (KMS)

It is commonly believed that an effective implementation of KMS enhances an organisation’s competitive advantage manifested in service quality improvement, significantly lower operational cost, improved coordination, etc. (Gupta et al., 2004). KMS improves the operational process integration and customer relationship interaction (Su and Yang, 2010), cost and time reductions, strengthened relationships among colleagues and quicker knowledge creation (Su & Lin, 2006; Huang & Lai, 2012). In comparison with other traditional systems such as document management system, knowledge management system can provide better help in avoiding duplicating efforts whilst assisting in the systematic coordination of capturing people’s knowledge and experience (Xu & Quaddus, 2012).

Although most organisations are at least aware of what their corporate knowledge assets are, managing these assets and making use of them to gain maximum returns is a different ball game altogether. Ironically, most KM systems deployed are not able to address this paradox despite the understanding and value they place on intellectual capital (Edwards, Shaw & Collier, 2005). Hence, it is no surprise that KM Systems today have failed to live up to its expectations and in some cases appear no more than an illustrious off-the-shelf content management system (Sukumaran & Chandran, 2014).

B. Tacit Knowledge Elicitation

It is important to reiterate that for KM systems to be deemed useful, the focus must be towards contextualised tacit knowledge (Sukumaran & Chandran, 2014). However, this in itself is a

challenge because it is widely recognized that the existence of tacit knowledge poses a unique problem and is a source of difficulty for the knowledge and requirements elicitation process (Christel, 1992; Gourlay, 2006; Friedrich & Van Der Poll, 2007). Sukumaran and Chandran, 2014 mentioned the need to examine the impact and purpose of a KM System from two perspectives. First the understanding and characteristics of tacit knowledge (experience and know-how). Secondly, what constitutes and shapes tacit knowledge. If these aspects are not adequately dealt with, the goal of eliciting tacit knowledge seems rather far-fetched as it has always been.

Hence, with the above being said, in addition to the FIVE (5) critical success factors espoused by KMPro, it is important that due emphasis and attention is given towards eliciting tacit knowledge over explicit knowledge. This is also due to the fact that prevailing KM systems are inundated with explicit knowledge leaving most mainstream KMS in operation no different than a typical content management or document management system. Much of these phenomena is due to the fact that tacit knowledge elicitation is a cumbersome process coupled with an absence of a suitable methodology to structure and guide elicitation of tacit knowledge. It is therefore not uncommon to witness a shift of focus amongst KM vendors and tool developers deploying functionalities that are focused primarily towards explicit knowledge as opposed to tacit knowledge. Much of these tools are garnished with over the top features that do not support KM. However, it is important to point out that tacit knowledge elicitation is the crux of a KM system (while not ruling out the importance of explicit knowledge) and is certainly the corner stone of a successful KM System. Functionalities like data analytics is as good as it gets and can only serve to generate rich analytics (i.e. output) assuming knowledge input was of significance. Therefore as the expression goes, “garbage in, garbage out” the importance and impact of tacit knowledge (i.e. knowledge input) cannot be discounted in churning out content that is of significance to the organisation.

C. Activity Theory

Arguably one of the key success factors of KM initiative lies in the context in which knowledge is captured, made relevant and leveraged for organizational gains (Alawi and Tiwana, 2002). This is however easily said than done. Lichtenstein and Swatman, (2002) argued that the human context within which a software system will operate is fundamental to its requirements. What is evident is that although the human context may not appear to

be very much related to the system, it is nonetheless very relevant in achieving its successful adoption and operationalisation of the ensuing KM System (Tan, 2009). Taking Tan's view in mind, there has to be a renewed approach to elicit knowledge in the context of KMS. The conventional approach in eliciting knowledge is unsuitable given the tacit and contextualized nature of knowledge. This phenomena has led the KM researcher to contemplate on the use of other supporting theories to aid in tacit knowledge elicitation. One such approach is the use of Activity Theory (AT). Activity Theory is not a "theory" in the strict interpretation of the term. AT is a paradigm for the analysis of human groups focused on their contextualized acts (Fernandez, Gomez and Pavon, 2009). AT through the use of an Activity System is also a guiding framework and a tool to facilitate elicitation of tacit understanding from a subject matter expert. Given the promise offered by AT, it remains to be seen if it does indeed fill the gap in being able to facilitate elicitation of contextualized tacit knowledge. Should this be the case, AT may well address the gap plaguing KMS of yesteryears.

III METHODOLOGY

Since the premise of the study was based upon the survey outcome of KMPro, it is imperative that the same instrument used in the KMPro survey is closely examined in this study. The authors have therefore scrutinised the survey question by extrapolating a list of 34 questions (See Appendix A) spanning across all five critical success factors namely KM Strategy, KM Measurement, KM Tools, Leadership Support and Organisational Culture. This exercise is crucial to review which of the elements within the survey questions were relevant inclusions in the conceptual framework and the ensuing KM System. The authors would like to make it known that the survey elements in Appendix A were produced entirely by the authors extrapolated using the official survey report released by KMPro. Therefore, at no time did KMPro release the survey elements. The listing in Appendix A does not necessarily constitute the actual contents of the survey instrument that was used by KMPro. Nonetheless, for all intents and purposes, the listing in Appendix A serves as a detailed breakdown and analysis of each of the five critical factors revisited in this study. To begin with, an analysis of 34 questions in Appendix A was carried out. Each question in the list were further categorised into two parts i.e. 'Relevance to KMS', 'Inclusion to the Framework' or both. 'Relevance to KMS' denotes that a particular survey element can be translated

into a potential KMS functionality whereas 'Inclusion to the Framework' espouses the fact that the outcome of the survey question is an important consideration in the framework development.

Taking question 33 in Appendix A as an example, "Employees in the organisation are evaluated based on sharing of critical knowledge"; this statement does not influence the framework development but does shape the functionality of a KMS. Therefore, only the column 'Relevance to KM' was checked.

IV CONCEPTUAL FRAMEWORK

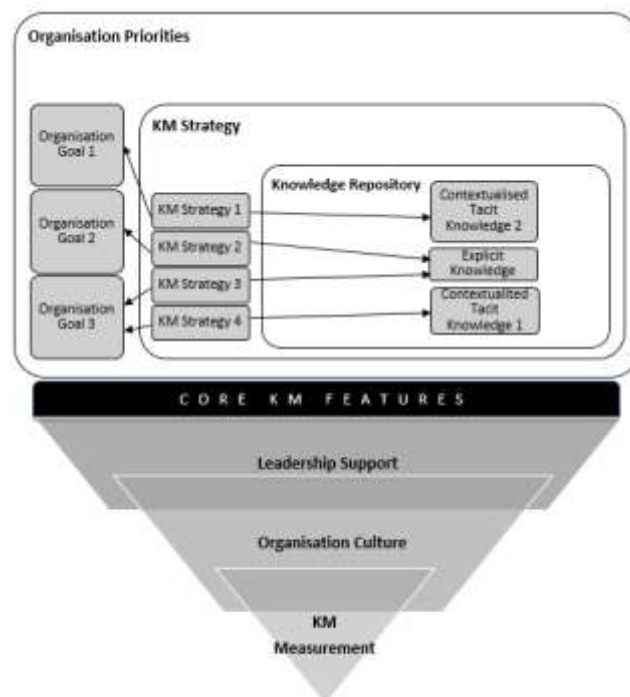

Figure 1. Conceptual Framework – Critical Factors for Development of KM Systems

Figure 1 summarizes the outcome of the findings. At the core of the proposed conceptual framework is the Knowledge Repository i.e. a repository of contextualised knowledge, tacit and/or explicit. Contextualised tacit knowledge will be elicited using tenets of Activity Theory discussed in section III of this paper. Knowledge stored in the repository needs to be mapped against one or more KM strategies. Similarly, KM strategies are mapped against one or more organisational goal(s). The outcome of the findings also reiterates the impact and relevance of leadership support, organisational culture and KM measurements as critical factors in the development of KMS. Therefore, these factors were also included in the framework to support knowledge elicitation. Finally the conceptual framework is augmented using 'Core KM Features' which is a list of KM functionalities listed in Appendix B.

The conceptual framework in Figure 1 by no means provides an adequate insight for KM developers and researchers to develop a successful KM System due to its highly abstract nature. Therefore, to develop a successful KM System, a detailed listing of specific KM functionalities (or features) is deemed necessary - see Appendix B.

Appendix B is a categorical list of 25 survey questions relevant to KMS (as opposed to 35 questions in Appendix A) spanning across FOUR (4) critical factors namely KM Strategy, KM Measurement, Leadership Support and Organisation Culture. A total of 48 KMS functionalities were subsequently derived and hereafter termed 'Core KMS Features' as shown in Figure 2.



Figure 2. Critical Factors – Core KMS Features

V DISCUSSION

The development of a KMS cannot commence without identifying organisational goals and its subsequent link to KM strategies. Similarly, the elicitation of tacit knowledge is achieved using tenets of Activity Theory (AT) elaborated at length in Sukumaran & Chandran (2014). The 'Core KM Features' which was mapped against the four critical factors could be statistically tested using procedures like confirmatory factor analysis to test its relevance.

Regression tests could be undertaken to understand if non-adherence to one or more critical factors could result in the failure or breakdown of the ensuing KMS. Further qualitative evaluations with subject matter experts are necessary to validate the 'Core KM Features' and its operational feasibility. Finally yet importantly, a KMS can be developed adorned with 'Core KMS Features' and deployed across several organisations in an attempt to triangulate the findings. It must be noted however, that the successful rollout and adoption of a KMS depends on many other factors such as seamless user interface, business process integration, motivational factors, change management, HR involvement, KM pilots, etc. which are beyond the scope of this paper.

VI CONCLUSION

The startling revelation based on the outcome of the recent 2016 KMPro survey opened a plethora of research opportunities. The KMPro study in general pointed out the impact of critical factors contributing to the success and failures of KM implementation.

This study dwelled on the findings of the abovementioned KMPro survey to ascertain if the same critical factors could guide successful KMS implementation and if specific KMS requirements or functionalities could be consequently extrapolated. Indeed a KMS is integral to any KM implementation project given that a KMS is typically deployed at the tail end of a KM implementation and is part of the overall KM strategy. This being the case, it is not surprising to observe significant correlations between critical success factors in implementing KM and the critical success factors to implement a KMS.

The findings of the research essentially unplugged the same. Conversely, the listing of 'Core KMS Features' as shown in Appendix B further exemplifies key elements to be considered in implementing a KMS. The proposed high-level conceptual framework provides the much needed building blocks in developing KMS of the future. The conceptual framework when used together with the catalogue of 'Core KMS Features' provides a guiding framework for KMS development efforts in the future.

REFERENCES

- Alavi, M., & Tiwana, A. (2002). Knowledge integration in virtual teams: The potential role of KMS. *Journal of the American Society for Information Science and Technology*, 53(12), 1029-1037.
- Alsène, E. (2007). ERP systems and the coordination of the enterprise. *Business Process Management Journal*, Vol. 13 Iss: 3, pp.417 - 432
- Christel, M. G., & Kang, K. C. (1992). Issues in requirements elicitation (No. CMU/SEI-92-TR-12). Carnegie-Mellon University Pittsburgh PA Software Engineering Institute.
- Edwards, J-S., Shaw, D, Collier, P-M (2005). Knowledge Management Systems – Finding a Way with Technology, *Journal of Knowledge Management*, Emerald Group Publishing Limited, Vol. 9 No. 1 2005, pp. 113-125, ISSN 1367-3270, doi: 10.1108/13673270510583009
- Engeström, Y. (1987). *Learning by Expanding: An Activity Theoretical Approach to Developmental Research*, Helsinki: Orienta-Konsultit, OY. Finland
- Fernández, R.F, Gómez-Sanz, J.J, Pavo'n, J. (2009). Understanding the human context in requirements elicitation, *Springer-Verlag, Requirements Eng (2010) 15:267–283*. doi: 10.1007/s00766-009-0087-714
- Gupta, S. and Lehman, D. R. (2005). *Managing Customers as Investments*, Upper Saddle River, NJ: Wharton School
- Friedrich, W. R., & Van Der Poll, J. A. (2007). Towards a methodology to elicit tacit domain knowledge from users. *Interdisciplinary journal of information, knowledge, and management*, 2(1), 179-193.
- Gourlay, S. (2006). Towards conceptual clarity for 'tacit knowledge': a review of empirical studies. *Knowledge Management Research & Practice*, 4(1), 60-69.
- Huang, L. S., & Lai, C. P. (2012). An investigation on critical success factors for knowledge management using structural equation modeling. *Procedia-Social and Behavioral Sciences*, 40, 24-30.
- Kaptelinin, V., & Nardi, B. A. (1997). Activity theory: basic concepts and applications. In *CHI'97 Extended Abstracts on Human Factors in Computing Systems* (pp. 158-159). ACM.
- Knoco Ltd. (2016). *Knowledge Management Reference*. Knowledge Management FAQ. [ONLINE] Retrieved from: <http://www.knoco.com/knowledge-management-FAQ.htm>.

- Knowledge Management Professional Society (KMPro) (2016). Retrieved from <http://kmpro.org/>
- Lichtenstein, S. and Swatman, P.M.C (2002). Sustainable knowledge management systems : inte-gration, personalisation and contextualisation, Deakin University School of Information Systems, Geelong, Vic.
- Su, H. Y., & Lin, Y. (2006). Enhancing knowledge-based service quality: A knowledge management perspective. *The Service Industries Journal*, 26(7), 787-800.
- Sukumaran, S., & Chandran, K. (2014). Knowledge Management Systems – The End of the Road?: Position Paper, 1, 186–194. doi:10.1007/978-3-319-08618-7.
- Wang, D. Zhongfeng, Su. and Yang, D. (2011). Organisational culture and knowledge creation capability, *Journal of Knowledge Management*, Vol. 15 Iss: 3, pp.363 - 373
- Xu, J., & Quaddus, M. (2012). Examining a model of knowledge management systems adoption and diffusion: A Partial Least Square approach. *Knowledge-Based Systems*, 27, 18-28.

Appendix A – Survey Questions mapped to ‘Relevance to KMS’ & ‘Inclusion to the Framework’

No	Survey Questions	Relevance to KMS	Inclusion to the Framework
Critical Factor #1: Knowledge Management Strategy			
1.	There is a perceived lack of KM strategy within the organisation.	<input checked="" type="checkbox"/>	<input checked="" type="checkbox"/>
2.	One of the most critical challenge faced in KM Implementation is the difficulty in getting top management buy-in, i.e. for top management to clearly understand what KM is and how organisational knowledge directly (or indirectly) connects to competitive advantage and innovation.	<input type="checkbox"/>	<input checked="" type="checkbox"/>
3.	To what extent is your organisation able to use its knowledge for competitive advantage?	<input checked="" type="checkbox"/>	<input checked="" type="checkbox"/>
4.	In your understanding, what knowledge makes the organisation unique (in terms of effectiveness, competitive advantage or innovation)?	<input checked="" type="checkbox"/>	<input checked="" type="checkbox"/>
5.	Do you have any metrics (stats) to substantiate the benefits of archived knowledge held in repositories in your organisation?	<input checked="" type="checkbox"/>	<input checked="" type="checkbox"/>
6.	Are you aware of the terms tacit and explicit knowledge?	<input checked="" type="checkbox"/>	<input checked="" type="checkbox"/>
7.	What is the knowledge focus of your organisation – tacit or explicit knowledge?	<input checked="" type="checkbox"/>	<input checked="" type="checkbox"/>
8.	What is the organisation’s main strategy in focusing on tacit knowledge?	<input checked="" type="checkbox"/>	<input checked="" type="checkbox"/>
9.	Does the organisation provide specific guidelines to assist in documenting tacit knowledge?	<input checked="" type="checkbox"/>	<input checked="" type="checkbox"/>
10.	What percentage of the organisation’s KM effort was spent capturing the knowledge held by people vs implementing KM technology?	<input checked="" type="checkbox"/>	<input checked="" type="checkbox"/>
11.	The approach of capturing of knowledge held by people in your organisation is best explained by:	<input checked="" type="checkbox"/>	<input checked="" type="checkbox"/>
12.	What is the primary mechanism for capturing knowledge held by people in your organisation?	<input checked="" type="checkbox"/>	<input checked="" type="checkbox"/>
13.	How effective or useful was the knowledge captured from people had resulted in improved effectiveness, competitive advantage or innovation?	<input checked="" type="checkbox"/>	<input checked="" type="checkbox"/>
14.	What is the primarily role of KM technology in your organisation?	<input checked="" type="checkbox"/>	<input checked="" type="checkbox"/>
15.	Are the contents of the document repository in your organisation aligned to the organisation’s strategic goals?	<input checked="" type="checkbox"/>	<input checked="" type="checkbox"/>
16.	The organisation has a KM Strategy in place?	<input checked="" type="checkbox"/>	<input checked="" type="checkbox"/>
17.	Does the organisation’s KM strategy fully support the organisation goals?	<input checked="" type="checkbox"/>	<input checked="" type="checkbox"/>
18.	The organisation has conducted a “Knowledge Gap” analysis as an input into the KM strategy?	<input type="checkbox"/>	<input checked="" type="checkbox"/>

Critical Factor #2: Knowledge Management Measurement			
19.	What do you think is the No. 1 anticipated benefit of KM?	<input checked="" type="checkbox"/>	<input checked="" type="checkbox"/>
20.	Are there metrics (stats) within the organisation to determine the impact of KM upon decision making?	<input checked="" type="checkbox"/>	<input checked="" type="checkbox"/>
21.	Are there metrics (stats) within the organisation to validate contributions (knowledge) on how it achieved organisation goals?	<input checked="" type="checkbox"/>	<input checked="" type="checkbox"/>
22.	The organisation is familiar with the concept of Knowledge Value-Added (KVA) measurement and it has been used as a KM performance indicator?	<input checked="" type="checkbox"/>	<input checked="" type="checkbox"/>
23.	The organisation has made no effort to quantify the actual value of the organisational knowledge?	<input checked="" type="checkbox"/>	<input checked="" type="checkbox"/>
24.	Are there metrics (stats) developed to measure the value-added contribution of knowledge to either of innovation or organisational effectiveness or competitive advantage.	<input checked="" type="checkbox"/>	<input checked="" type="checkbox"/>
Critical Factor #3: Knowledge Management Tools			
25.	There is a near total focus upon the usage of IT tools as the primary component (or in many cases, the sole component) of the KM effort in the organisation.	<input checked="" type="checkbox"/>	<input checked="" type="checkbox"/>
26.	KM tool was selected and put into place in the organisation without any regard for any KM strategy or even any needs-based or performance gap analysis?	<input checked="" type="checkbox"/>	<input checked="" type="checkbox"/>
27.	The KM tool chosen was inadequate or had failed to best meet needs and achieving the organisation goals?	<input checked="" type="checkbox"/>	<input checked="" type="checkbox"/>
28.	No efforts were made to replace the bad tool presumably because:	<input type="checkbox"/>	<input checked="" type="checkbox"/>
Critical Factor #4: Leadership Support / Governance			
29.	Non-KM managers within the organisation feel that they had no responsibility or role in supporting KM within the organisation.	<input checked="" type="checkbox"/>	<input checked="" type="checkbox"/>
30.	KM roles are decentralized within the organisation, with little to no connectivity between their separate areas, and no coordination between their managers regarding the KM strategy.	<input checked="" type="checkbox"/>	<input checked="" type="checkbox"/>
31.	There are no specific measurements in place to hold non-KM managers within the organisation accountable for knowledge sharing, transfer or utilization within their own areas of responsibility.	<input checked="" type="checkbox"/>	<input checked="" type="checkbox"/>
Critical Factor #5: Organisation Culture			
32.	The organisation strives to build a knowledge sharing culture was a top- priority by putting in place recognition and reward systems.	<input checked="" type="checkbox"/>	<input type="checkbox"/>
33.	Employees in the organisation are evaluated based on sharing of critical knowledge.	<input checked="" type="checkbox"/>	<input type="checkbox"/>
34.	The organisation strives to validate whether employees had an adequate understanding of their role in ensuring that critical knowledge is created, captured, shared and leveraged.	<input checked="" type="checkbox"/>	<input type="checkbox"/>

Appendix B – Core KMS Features

No	Survey Question	KMS Functionality
Critical Factor #1: Knowledge Management Strategy		
1.	There is a perceived lack of KM strategy within the organisation.	<input checked="" type="checkbox"/> Manage KM Strategy
2.	One of the most critical challenge faced in KM Implementation is the difficulty in getting top management buy-in, i.e. for top management to clearly understand what KM is and how organisational knowledge directly (or indirectly) connects to competitive advantage and innovation.	<input checked="" type="checkbox"/> Manage Stakeholders <input checked="" type="checkbox"/> Analytics – KVA <input checked="" type="checkbox"/> Analytics – Knowledge Accessed
3.	To what extent is your organisation able to use its knowledge for competitive advantage?	<input checked="" type="checkbox"/> Analytics-Knowledge Mapped to KM Strategy <input checked="" type="checkbox"/> Analytics- Analytics-Knowledge Mapped to KM Strategy & Accessed
4.	In your understanding, what knowledge makes the organisation unique (in terms of effectiveness, competitive advantage or innovation)?	<input checked="" type="checkbox"/> Manage KM activities mapped against KM Strategy <input checked="" type="checkbox"/> Retrieve knowledge-by project / activity / lessons learned
5.	Do you have any metrics (stats) to substantiate the benefits of archived knowledge held in repositories in your organisation?	<input checked="" type="checkbox"/> Knowledge log
6.	What is the knowledge focus of your organisation – tacit or explicit knowledge?	<input checked="" type="checkbox"/> Manage tacit knowledge <input checked="" type="checkbox"/> Manage (Add, Update, Delete, View, Search) explicit knowledge
7.	What is the organisation’s main strategy in focusing on tacit knowledge?	<input checked="" type="checkbox"/> Compute knowledge asset (by project / employee / activity / group) <input checked="" type="checkbox"/> Manage Organisation Goals
8.	Does the organisation provide specific guidelines to assist in documenting tacit knowledge?	<input checked="" type="checkbox"/> Manage KM policy
9.	The approach of capturing of knowledge held by people in your organisation is best explained by:	<input checked="" type="checkbox"/> Manage expertise – tacit or explicit (by project / activity / group)
10.	What is the primary mechanism for capturing knowledge held by people in your organisation?	<input checked="" type="checkbox"/> Manage content - flowchart / document / natural language
11.	How effective or useful was the knowledge captured from people had resulted in improved effectiveness, competitive advantage or innovation?	<input checked="" type="checkbox"/> Manage rating
12.	What is the primarily role of KM technology in your organisation?	<input checked="" type="checkbox"/> Generate report <input checked="" type="checkbox"/> Ask Me <input checked="" type="checkbox"/> Quick search <input checked="" type="checkbox"/> Advanced search
13.	Are the contents of the document repository in your organisation aligned to the organisation’s strategic goals?	<input checked="" type="checkbox"/> Document tagging
14.	Does the organisation’s KM strategy fully support the organisation goals?	<input checked="" type="checkbox"/> Map KM Strategy against Organisation Goals
15.	The organisation has a conducted a “Knowledge Gap” analysis as an input into the KM strategy?	<input checked="" type="checkbox"/> Document Knowledge Gap

No.	Survey Question	KMS Functionality
Critical Factor #2: Knowledge Management Measurement		
16.	Are there metrics (stats) within the organisation to determine the impact of KM upon decision making?	<input checked="" type="checkbox"/> Analytics – Knowledge Retrieved <input checked="" type="checkbox"/> Analytics – KM Individual Awareness Ratio <input checked="" type="checkbox"/> KM Poll
17.	Are there metrics (stats) within the organisation to validate contributions (knowledge) on how it achieved organisation goals?	<input checked="" type="checkbox"/> Analytics-Organisation Goals index (percentage of knowledge mapped against KM strategy & KM strategy mapped against Organisation Goals
18.	The organisation is familiar with the concept of Knowledge Value-Added (KVA) measurement and it has been used as a KM performance indicator?	<input checked="" type="checkbox"/> Measure KVA
19.	The organisation has made no effort to quantify the actual value of the organisational knowledge?	<input checked="" type="checkbox"/> Add knowledge value <input checked="" type="checkbox"/> Manage knowledge
20.	Are there metrics (stats) developed to measure the value-added contribution of knowledge to either of innovation or organisational effectiveness or competitive advantage.	<input checked="" type="checkbox"/> Measure KVA <input checked="" type="checkbox"/> Add best practices <input checked="" type="checkbox"/> Add business processes
Critical Factor #4: Leadership Support / Governance		
21.	Non-KM managers within the organisation feel that they had no responsibility or role in supporting KM within the organisation.	<input checked="" type="checkbox"/> Manage knowledge worker <input checked="" type="checkbox"/> Manage knowledge manager
22.	There are no specific measurements in place to hold non-KM managers within the organisation accountable for knowledge sharing, transfer or utilization within their own areas of responsibility.	<input checked="" type="checkbox"/> Analytics-Knowledge sharing index <input checked="" type="checkbox"/> KM Push notification <input checked="" type="checkbox"/> KM Reminders <input checked="" type="checkbox"/> Analytics-Knowledge utilisation index
Critical Factor #5: Organisation Culture		
23.	The organisation strives to build a knowledge sharing culture was a top- priority by putting in place recognition and reward systems.	<input checked="" type="checkbox"/> Manage rewards <input checked="" type="checkbox"/> Manage ranking <input checked="" type="checkbox"/> Manage privacy <input checked="" type="checkbox"/> Manage confidentially <input checked="" type="checkbox"/> Request knowledge
24.	Employees in the organisation are evaluated based on sharing of critical knowledge.	<input checked="" type="checkbox"/> Analytics-Employee KM index
25.	The organisation strives to validate whether employees had an adequate understanding of their role in ensuring that critical knowledge is created, captured, shared and leveraged.	<input checked="" type="checkbox"/> Verify knowledge* <input checked="" type="checkbox"/> Validate knowledge* *workflow based approval

Malaycious: Usable Mobile Food Finding Application

Lee Pui Yen and Zarul Fitri Zaaba

Universiti Sains, Malaysia, Malaysia, lpyen.ucom12@student.usm.my, zarulfitri@usm.my

ABSTRACT

Food-finding application is an application that provides users with classified and suggestive information about the local food one particular country. Apparently, there are numbers of the food-finding applications in the Malaysia's apps market such as Malaysia Food diary, Hungrygowhere, FoodSpotting etc. However, lacks of classified and suggestive information are the main limitations of the current applications. In order to overcome the limitations of the existing applications, features such as augmented reality, photographic food diary, and smart budget are implemented in the proposed solution. A survey is conducted to understand end-users insights on their usage of food finding application in Malaysia. Based on the gathered evidence, Malaycious is introduced as a new food finding application that bridges the gap of known challenges. Augmented reality (AR) is implemented in the proposed system to enrich users camera feed with contextual information. Users can now benefits from the ability to the place computer generated graphics in the field of vision. Besides that, shooting food becomes one of the fastest growing hobbies for people nowadays. Therefore, the proposed application will include a new feature called Photographic Food Diary to store that pictures that users capture. Therefore, users can recall back the images and also the information of the images. In addition, Smart Budget is a feature that help users to filter the food according to the preferences that user entered. The detail discussion were provided in the relation to the development of Malaycious. Therefore, it can be suggested that Malaycious provide usable and user-friendly food-finding application.

Keywords: Augmented Reality, Intelligent System, Usability, Mobile Application, Food-finding.

I INTRODUCTION

Malaysia is a multi-ethnic and multi-religious country. It includes Malay, Chinese, Indian and other ethnicity. People also connect to their cultural or ethnic group through similar food patterns. Food represents the cultural identity. The ingredients,

methods of preparation and preservation techniques at different meals are varied among cultures. In addition, food can be associated with hospitality and expression of friendship. Therefore, sensitivity to food rules and customs is important to build and to strengthen the cross-cultural relationships. Having multiracial people with various ethics and cultures promote Malaysia's food to another level especially from the international perspective.

Statistical evidences from The Tourism Malaysia stated that there is a continuous growth in total number of tourist in Malaysia from the year 1998 to 2014. In addition RM51.1 billion was contributed to Malaysia's Gross National Income (GNI) in the year 2013 from the tourism industry. From January to May, Malaysia welcomed a total of 11.53 million (11,532,859) tourists, registering a hike of 10.1% compared to 10.48 million (10,478,419) tourists for the same period last year (Tourism in Malaysia, 2015). This indicates that tourism plays an important role for Malaysia development. This industry effects positively on the economy of Malaysia. Based on the Tourism Malaysia official website, their objective is to promote Malaysia as an outstanding tourist destination (Tourism Malaysia Official Website, 2010). Besides that, a report by CNN Travel shows that Malaysia is one of the Top 10 countries that have the most delicious food in the world. Penang assam laksa places 7 out of 50 foods around the world (CNN Travel, 2015).

Therefore, in this paper is mainly to research on food-finding application that currently in the market, identify the features of the applications and hence develop solution and implement a food-finding application that contain features to solve the problem face by users. This paper organize as follows, related works will provide useful literature about the problems and comparison of the existing system, preliminary study highlights the survey results, the proposed solution introduces the *Malaycious* as means of solution which explain the modules involve and discussion about the overall analysis and finally ending with the conclusion and future work.

II RELATED WORK

Nowadays, people can easily access or search the information they want with the introduction of WiFi or mobile Internet. They can easily get their

information with just few clicks. Compare to the olden days, now travelling is no longer a difficult task. People no longer worried about lost in a country. With the use of the GPS navigation application, users can easily retrieve the route information, view the location on the map or even explore around the area destination through 360-degree, panoramic and street-level imagery.

Based on the investigation, none of the existing food –finding application in the market provides one-fits-all solutions in a single application. In fact, the features are being separately implemented in different applications. In order to obtain all the information, users are required to download different applications which also need extra memory space and additional cost to store it. For example, “Street Food” (Google Play store, 2015) is an application that integrated with Malaysia’s local food recommendation feature, which is not implemented in any other food-finding application that is available in today’s market. However, “Street Food” application contains its own limitation. It does not provide users with the location of dine-in places where the users are able to find the local foods mentioned in the application. Thus, users have to use a separated GPS navigation system or virtual map application in order to obtain the location information of the dine-in places where they are able find the foods recommended.

Today, people enjoy showing to the world what they eat by photographing every meal, revealing themselves perhaps more vividly than they might by merely reciting the names of appetizers and entrees (i.e. foods and drinks). There are many existing application allows user to take and store their pictures. However, this function normally is not embedded with the food-finding application. Thus, users have to download another application to capture and to store their images.

Food-finding applications can be viewed from two main perspective which are local market (i.e. Malaysia context) and international markets. However, most of those applications do not equip with all the features as shown in Table 1 and Table 2 (Google Play Store, 2015). The “√” in the tables indicate that the applications contain certain features and the “-” indicate the applications do not contain certain features.

Table 5. Existing food finding application in the local market (Google Play Store, 2015).

Application Feature	Food Spotting	Hungry gowhere	Four square	Kuala Lumpur Travel Guide and Offline City Map	Malaysia Food Diary	Malaycious
Location on map	√	√	√	√	√	√
Locations Nearby	√	√	√	√	√	√
Local food description	√	√	√	-	√	√
Smart Budget	-	-	-	-	-	√
GPS navigation	√	-	√	-	√	√
Photographic Food Diary	-	-	-	-	-	√
Augmented Reality	-	-	-	-	-	√
Top 10 Must Try Food	-	√	-	-	-	√
Translator	-	-	-	-	-	√
Malaysia’s Map	√	√	√	√	√	√

Table 1 shows a comparison of food-finding applications. *Foodspotting* is an application that discover nearby dishes and restaurants. *Food spotting* also contains several features such as GPS navigation, nearby locations, Malaysia’s map and so on. However, it does not have the Smart budget feature. This feature is to filter foods according to the price that user has entered. It also does not contain Photographic Food Diary features that allow users to store their food images. *Hungry Go Where* is another application that contains more or least the same features as Food spotting. This application consists of the Top 10 dishes must try features. On the other hand, *Kuala Lumpur Travel Guide and Offline City Map* is an application that contains offline map. However, it does not help users to find nearby restaurant and do not have the smart budget feature. Besides that, *Malaysia Food Diary* is an application that developed by the former student of Universiti Sains Malaysia. In this application, it contains some of the functions compared to *Malaycious*. However, it does not contain the features such as Smart Budget, Photographic Food Diary, Augmented Reality and Top 10 Must Try foods.

Table 6. The existing food finding application in the international market (Google play Store, 2015)

Applications	Zomato	Food Network On The Road	Find Dining: Restaurant Finder	Street Lens
Location on map	✓	✓	✓	✓
Locations Nearby	✓	✓	✓	✓
Local food description	✓	✓	✓	-
Smart Budget	-	-	-	-
GPS navigation	✓	✓	✓	✓
Photographic Food Diary	-	-	-	-
Augmented Reality	-	-	-	✓
Top 10 Must Try Food	-	-	-	-
Translator	-	-	-	-
Malaysia's map	-	-	-	-

Four applications have been chosen from the international market based on its popularity usage and rating. In Table 2, *Zomato* is an existing application that discovers the best restaurant in the world. It also can use the map feature to explore every restaurant in the city, including the ones around current locations or filters and find the one that suits you the best. Besides that, it also does not contain the features like Photographic Food Diary. *Food on the Road* and *Food Dining: Restaurant Finder* has the same features. The features of this application are more or less similar to *Zomato*. However, it can direct user to the place with GPS navigation but *Zomato* does not provide this function. *Street Lens* is another application that already existed in the market. *Street Lens* provides special features where others applications do not, which is the augmented reality function. However, *Street Lens* is not a fully food-finding application.

From the tables above, it can be noted that the existing applications in the local and international markets contain the main features like location on map, locations nearby and local food description. Besides that, it is clearly show that the existing application in the international market also consist of GPS navigation features which cannot be found in the local market. However, the existing applications in both markets do not equip with some of the main features such as smart budget, photographic food diary and augmented reality. It also can be noted that none of the applications contain the augmented reality feature and photographic food diary. These are the features that can provide more useful information to users. For augmented reality, it is a new technology that should be implementing in the application. In addition, photographic food diary allows the users to capture and store the moments in the applications. Smart budget features also not

implemented in the existing applications of local and international market.

There are significant gaps exists in the food-finding application. Therefore, it open a room of improvement to develop a better food-finding application. This paper introduced *Malaycious* as a new food-finding application (i.e. highlighted in Table 1). *Malaycious* is an application that help users especially tourists in Malaysia by providing the classified and suggestive information to the users. *Malaycious* provide functionality such as Augmented Reality, Photographic Food Diary , Smart Budget, Top 10 local food and food festival promotional.

According to Julie Carmingniani et al. (2011), Sir Ivan Sutherland creates the first augmented reality system; the optical see-through head-mounted display is used, tracked by 6DOF trackers in 1968. In 1990, Prof. Tom Caudell coined the term “Augmented Reality”, and developed system to assemble cables into aircraft to help technicians at Boeing. In 1994, Steve Mann wearing a webcam which combine the mobile camera and connected to his website, allowing online visitors to comment on what he saw in daily lifes. Then in 1999, Hirokazu Kato of the Nara Institute of Science and Technology and Mark Billinghurst present the ARToolKit utilising the pose tracking library with six degree of freedom. It was then published to the open source community to be used.

III PRELIMINARY STUDY

The survey method aimed to judge the subjective feelings of people with respect to specific studies (Fowler 1993). It may be noted that questionnaire using the Internet was cheap, quicker feedback and less missing data (Nowack 1997).

This online survey is designed for adult participants, target participants must be aged 18 years old and older with the closed-ended question and multiple choices of the answer. The survey is promoted in social media such as Facebook, word of mouth and through email. The survey is also posted in the USM Info Sharing Group in Facebook. The results of the survey is showed in Table 1.

Table 3. Demographic Result

Questions	Frequency (N = 144)	Percentage (%)
Age Range		
18 – 25	103	70.5
26 – 33	27	19.9
34 – 41	8	5.5
42 - 49	4	2.7
> 50	2	1.4

Do you think Malaysia's food should be introduced to the world?		
Yes	133	93
No	6	4.2
Not Sure	4	2.8
Do you think it is easy to find Malaysia related food finding application in the market?		
Yes	44	30.8
No	62	43.4
Not Sure	37	25.9
How do you feel with about the tourism industry in Malaysia?		
Excellent	7	4.9
Good	62	43.4
Satisfactory	53	37.1
Weak	15	10.5
Really Weak	6	4.2
Most preferable place to travel		
Europe	42	28.8
ASEAN (i.e. Indonesia, Thailand, etc.)	11	7.5
East Asian (i.e. Japan, Korea, Taiwan)	69	47.3
Malaysia	24	16.4
Most preferable way to travel		
Buy Package Tour	18	12.5
Hire local tour guide	32	22.2
Self-guided tour	94	65.3
Activities during travel		
Visit all the famous places	93	64.1
Looking for local famous foods	100	69
Shopping	43	29.7
Sight-Seeing	71	49
Make new friends	8	5.5
What brand of smartphone you use?		
Apple	37	25.7
Microsoft	3	2.1
Lenovo	11	7.6
Samsung	61	42.4
Sony	11	7.6
Blackberry	2	1.4
Vivo	1	0.7
Others	18	12.5
Do you use the food-finding application during travel?		
Yes	62	42.5
No	84	57.5
If yes, what are the disadvantages of the current food-finding application?		
Lack of information	38	62.3
Not user-friendly interface.	31	50.8
Not much unique function.	21	34.4
No recommendation. (i.e. food, places)	8	13.1
Too simple.	4	6.6
Others: Always wrong information; Some are heavily influenced by the sponsors.	3	4.9

What are the features do you wish to be embedded in the current food-finding application?		
More useful information.	49	80.3
User friendly function.	32	52.5
Unique function.	15	24.6
Recommendation (i.e. food, places)	18	29.5
Free Application	14	23
Compatible with any platforms.	3	4.9

The survey results as shown in Table 3 suggested a total number of 144 responses. The respondents are all Malaysian from different age range and majority of them are student who aged between 18-25 years old. There are 133 responses (92%) think that Malaysia's food should be introduced to the world. 62 respondents (43.4%) think that it is not easy to find Malaysia related food-finding applications in the market. In addition, there are 33 out of 144 respondents are not sure whether it is easy to find Malaysia related food-finding applications. There are 47.3% of the responses prefer to travel around East Asian region such as Korea, Japan, and Taiwan and so on. Besides that, there are more than half of the respondents or in an accurate 65.3% of them prefer travel in self-guided tour while only 12.5% of the respondents prefer to buy package tour. 69% of them like to search for local famous foods as the top activities during travel followed by visiting the famous places and sight-seeing. Next, based on the result polled from the question on the disadvantages of the current existing food-finding application, 62.3% of the responses show that the current existing food-finding application in the market are lack of information about the foods. In addition, there are 50.8% of the responses think that the current existing food-finding applications do not have user-friendly interface and 34.4% of responses think that the food-finding applications do not have unique function.

IV PROPOSED SOLUTION

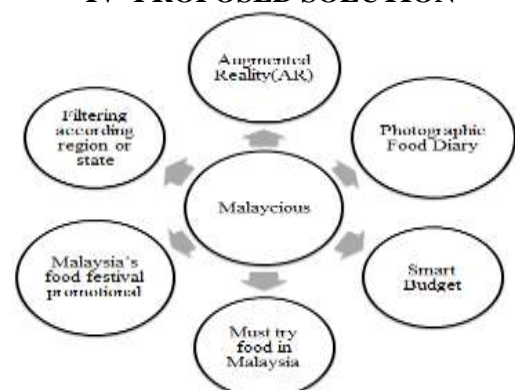

Figure 1. Malycious Modules

Based on the result of the survey, it can be suggested that the food-finding application should utilize features to provide more information, more user friendly interface, and recommendation of food and places. *Malaycious* is introduced as a means of solution with android platform. Basically the main function of *Malaycious* is to be used as the food- finding application that utilizes augmented reality, Photographic Food Diary and Malaysia's Food festival promotional to provide more classified information to the users. *Malaycious* consist of six main modules (Figure 1), augmented reality (AR) for location, photographic food diary, Smart Budget, Top 10 Must Try food, Malaysia Food Festival promotion, and filtering according the region or state.

A. System design and Implementation



Figure 2. *Malaycious* Architecture Diagram

The Figure 2 shows the architecture diagram of *Malaycious*. The users access the application through their smartphones. Users are required to connect WiFi or mobile network in order to access the application. Once the smartphones are connected to the Internet, data is retrieved from the server storage. Users can send or request data from the server storage. For instance, user can add, edit, delete, and view by sending request to the server storage. The actions will be performed and stored into the server storage. Besides that, navigation information is retrieved from Google API. The data that retrieved from Google API is sent to the user's smart phone via the Internet. The data from the Google API is used to solve the Travelling Salesman Problem (TSP). The data such as distances and the duration required between two points are used in the Genetic Algorithm. Genetic algorithm uses the data from Google API to find the optimal path of the vertex.

B. Augmented Reality for Location

AR mobile platform is enhancing integration of virtual objects in outdoor environment (Mohamad El-Zayat 2011). The first function of this application is the augmented reality for location. This function displays the Point of Interest (POI) depend on the user's current position. The POI will be displayed on screen of the user's device. In

short, the POI is drawn on the camera view of the device.

The augmented reality function starts with detecting the position of user. All the nearby restaurants that within the radius of 1km from the user's location are displayed in camera view. This feature allows user to efficiently obtain all the nearby restaurants based on user's current location. Users can click on the POI to get the details of the restaurant.



Figure 3. Augmented Reality Function in Prototype

C. Photographic Food Diary

Photographic food function capture and store the image that captured by the user. This function is similar to the diary but it only stored the pictures. For example, users can capture the food images; enter the details such as place, price and comments about the image. The images are displayed according to the date of user uploaded. This feature is to help user to record and capture the moments that they have experienced before. Besides that, users are able to nominate their pictures to the *Top 10 Must Try food*. The higher the average rating in the nominated food list, it then will be at the Top 10 list. Each of the users can only nominate the picture once. The average of the rating will be calculated according to the number of users. If the number of average rating in the nominated list is higher compared *Top 10 must try food* list, the nominated food will be ranked in the *Top 10 must try food* list. Equation (1) is an equation that calculates the average rating of the nominated food.

$$\text{verage rating} = \frac{\text{Total Rating of Nominated Food}}{\text{Total Numbers of Users.}} \quad (1) \quad \square$$



Figure 4. Interface of the Nominated Foods



Figure 5. Details of the Nominated Food

D. Smart Budget

Smart budget is the function that helps user to filter the restaurants according to their preferences. It list out all the restaurants according to the preferences of users such as price, popular, halal, spicy preference, meals and cuisines. There is MapView function at the bottom of the filtered restaurants. This function will display the entire filtered restaurants in a map. The function of MapView has the same problem as Travelling Salesman Problem. Travelling Salesman problems (TSP) is a well-known NP-hard optimization problem, requires the determination of the shortest route passing through a set of cities under the condition that each city must visited exactly once (Yu Yang 2010). Yu Yang 2010 also stated that Genetic algorithm is one of the famous algorithms has always been used to solve the TSP. Thus, genetic algorithm is chosen in this proposed solution. Genetic algorithm is applied when the MapView button is clicked. Genetic algorithm is an algorithm that is used to find the optimal path between the points given. This algorithm will choose the optimal path by visiting the selected restaurants exactly once. This algorithm is able to find the fitness route among the selected restaurants.



Figure 6. List of restaurants



Figure 7. Restaurants on Map

E. Top 10 Local Food

This function is listed out the Top 10 Must Try Local Food in Malaysia. The top 10 Local Food will be ranked according to the average rating of the food. The higher the rating, it will be at the top of the list.

$$\text{Average Rating} = \frac{\text{Total rating of the Local Food}}{\text{Total Number of Users}} \quad (2)$$

Equation (2) is an equation that calculates the average rating of the ranking of the local food.

The food ranking will be displayed together with the image of the local food. User can click into the images to have further details of the food. In the details page of the Foods, user is able to check which restaurants have sold this kind of food. From there, user is able to get more detailed information such as name, description, address and contact.



Figure 8. List of Top 10 Local Food



Figure 9. Details of selected local food

F. Malaysia's Food Festival Promotional

Normally, user can only obtain the food festival information from the Television or Internet. Based on the investigation, most of the food-finding applications in Malaysia do not provide this functionality. Therefore, *Malaycious* provide the latest information of the food festivals that currently held in Malaysia. In this feature, users are able to add the food festival event that they wish to the calendar of the phone. The date is set at the calendar of the phone. When the date of the festival is reached, push notification is popped up to notify users. With this feature, users are able to obtain the latest food festival information.



Figure 10. Food Festivals in Penang



Figure 11. Details of Food Festivals in Penang

G. Filtering According Region or State

This feature allows user to filter the food according to the region or state. This purpose of this feature is to filter or providing specific information to the users rather than generic one. By clicking the markers in the map, the food of the selected state is filtered.



Figure 12. Welcome page of the application.



Figure 13. Regions or state in Malaysia

V DISCUSSION

The preliminary study which utilizes the survey of 144 participants has been conducted to investigate the current issues of the existing food application in the current market. One of the issues has been highlighted was the ease to use factor and lack of useful information. *Malaycious* will counterbalance the problems. *Malaycious* is developed as a mean to improve the existing food-

finding application. The user of *Malaycious* is expected to be locals and the tourist of Malaysia. By using such application, it will help them to gain more information, help in navigation, and obtain more classified and suggestive information in augmented reality. Genetic algorithm is modified and implemented to solve the Travelling Salesman Problem. This algorithm enhances the work of finding the optimal path of the restaurants.

VI CONCLUSION AND FUTURE WORKS

In conclusion, the existing food-finding application in the market can be significantly improved. Since the existing food-finding application do not contain much features (i.e Augmented Reality, Photographic Food Diary, Smart Budget etc). It can be viewed the current results of this development is pretty convincing. *Malaycious* is in the final phase of development where it needs to be evaluated and validated. The limitations of this application are related on the issues of online or offline of data (i.e. must have Internet connection). In addition, results of the evaluation have not been discussed (i.e. still ongoing). *Malaycious* has a great potential to be used as intelligent tool to promote Malaysia Tourism.

REFERENCES

- CNN Travel. (2011). World's 50 best foods. Retrieved from <http://travel.cnn.com/explorations/eat/worlds-50-most-delicious-foods-067535/>
- Dining & Wine, Best Food. Online. Retrieved from http://www.nytimes.com/2010/04/07/dining/07camera.html?_r=0
- Floyd J.Fowler (1993), *Survey Research methods(2nd)*. Newbury Park, CA:Sage Publication, Intoudction.
- Google Play Store, Google. Online. Retrieved from <https://play.google.com/store?hl=en>
- Julie Carmigniani, Borko Furht,Marco Anisetti,Paol Ceravolo, Ernesto Damiani,Misa Ivkovic (2011) , *Multimed Tools Appl 2011, Augemented Reality Technologies ,Systems and Applications*
- Ling, L., Q., Karim, M., S., A., Othman, M., Adzahan, N., M., & Ramachandran, S, (2010), Relationships Between Malaysian Food Image, Tourist Satisfaction and Behavioural Intention, *World Applied Sciences Journal*, Vol.10, pp.164-171
- Mohamed El-Zayat (2011), *Augmented Reality Platform for Enhancing Integration of Virtual Objects*, Proceedings of CESC 2011: the 15th Central European Seminar on Computer Graphics.
- The Star Online. (2014). More Tourist Arrivals to Malaysia in Comparison to last year. Retrieved from <http://www.thestar.com.my/travel/malaysia/2014/10/16/more-tourist-arrivals-to-malaysia-in-comparison-to-last-year/>
- Tourism Malaysia Official Website (2016). Holiday To Malaysia. Retrieved from <http://www.tourism.gov.my/en/my>
- Yu Yang, Hongwei Dai, Hui Li, (2010) , *Adaptive Genetic Algorithm with Application for Solving Travelling Salesman Problems*, Institute of electrical and Electronics Engineers.

Empowering the Youth Through Online Social Enterprise Income Generation: A Study in Malaysia and USA

Noormaizatul Akmar Ishak¹, Muhamad Zulkiflee Osman², Syed Zulkarnain Syed Idrus¹, Wan Nor Ashiqin Wan Ali¹, Azizan Bahari¹, and Nur Azila Azahari¹

¹Universiti Malaysia Perlis, Malaysia, maizatul@unimap.edu.my

²Universiti Kuala Lumpur Business School, Malaysia, mzulkiflee@unikl.edu.my

ABSTRACT

As Malaysia's economy becomes increasingly developed, the quality of its education improves along with income ranks. However, the issue of school dropouts is "a thorn in the flesh" that affects the rise in income and hence the quality of life in Malaysia. As such the dropouts need to be exposed to self-empowerment and systematic financial education in order to be independent and at the same time able to steer themselves away from the dangers of crime. Taking advantage of the current digital trend, most of the dropouts are familiar with the Information and Communication technology (ICT), the internet and mobile applications. This study recommends that for the next phase in their dealing with school dropouts, the Malaysian authorities should build a prototype of the business model of Social Enterprise that is successfully in operation in the United States. Nevertheless, some adaptation should be made in order to suit with the Malaysian context. In the final phase, the authorities could also work out spin-off businesses through provision of seed funds, including from interested private sectors, to these youths.

Keywords: Social enterprise, online income, youth, online social enterprise

I INTRODUCTION

Dropout problem among young people requires serious attention. This is especially so when it affects those in the Primary School level (Azmi and Hashim, 2014). "Dropouts" here is defined as young people who cannot continue schooling due to their inability to cope with the school system or rejected it in order to pursue alternative lifestyle.

The government has tried to deal with the problem through the setting up of a committee in the early 1970s. Murad Mohamad Noor, the then Director of Planning and Research Division at the Ministry of Education was appointed as chairperson of the committee whose 1973 report on dropouts contained proposals to be implemented (by the government) in stages.

Youth development and empowerment are vital stages in life for building the human capital that allows young people to avoid poverty and lead better, and possibly have a more fulfilling life (Awogbenle and Iwuamadi, 2010). When the students dropout problem is persists, the country such as Malaysia will face the challenge to implement lifelong learning concept which is critical in order to increase productivity and employment opportunities for its citizen besides enriching the soul and mind with knowledge quality (Azmi and Hashim, 2014). In developing human capital, the Malaysian government wants the access to educational opportunities to be opened as wide as possible. Therefore, it is important to provide the knowledge of science and technology to the students so that they will become talents as well as workers who can contribute to the national development (Azmi and Hashim, 2014).

The term Web 2.0 is often used interchangeably with Social Network, that refers to applications such as wikis, blogs, Internet-based networks, websites for sharing multimedia content, group radio and instant messaging, as well as older forms of online collaboration (Taylor-Smith and Lindner, 2009). The main purposes for using Social Network tools to promote online participation are to reach more people in the target group to encourage them to get involved, to facilitate viral marketing of the project, and to keep people interested, through regular updates and the chance to establish comparatively sustainable computer-mediated relationships (Taylor-Smith and Lindner, 2009). Furthermore, many Social Network tools are also free to use. However, this study is of the view that the dropouts can find an opportunity to generate income through keeping Social Network sites up to date and providing information that requires staff to perform their tasks and this needs to be factored into any estimates of resource consumption in using these tools. According to report produced by the Malaysian Communications and Multimedia Commission (MCMC) in 2014, in terms of educational attainment, the survey conducted found one-third of users (33.7%) have attained a medium

level of education. Medium in this context, refers to the Sijil Pelajaran Malaysia/Sijil Pelajaran Vokasional Malaysia (SPM/SPVM) and Sijil Tinggi Pelajaran Malaysia (STPM). This is followed by low education group; primary school, secondary school, Penilaian Menengah Rendah (PMR) (27.8%) and high level of education; diploma, advanced diploma, degree and higher degree (21.7%). Statistically, education is not a strong indicator of hand phone usage as most phones are made user friendly, especially smart phones.

During the last decades, the communication technology has been transforming one's lifestyle into "Digital Life Style", in which one can create, share, and enjoy multimedia information in his own personalized virtual space in mobile environment (Lee, 2003). In digital lifestyle aggregators, all communications will be done through multipurpose digital devices and mobile applications where more information is published digitally on the webs and more people will read them than from anywhere else. As a result, the secret of making money is in providing an integrated environment for users to use Internet such as instant messaging, built-in digital camera, image gallery, cell phone gateways, personal publishing, and web services easily and seamlessly (Charmonman and Chorpothong, 2005). Digital civil society offers easily accessible multimedia contents for diversified user applications, communication and information infrastructure to support such access from user, and intelligent user devices to deliver such digital contents in user friendly manner (Lee, 2003). Generating income through e-Commerce is using the Internet for selling and buying of products and services. It includes advertising and catalogs of products and services by the seller, ordering of the products or services by the buyer, checking of the buyer's credit by the bank, manufacturing or taking the products from the shelves to be sent to the buyer, transferring of money from the buyer's account to the seller's account, as well as providing after-sales services (Charmonman and Chorpothong, 2005). Other than e-Commerce, digital lifestyle makes our home, entertainment and learning available digitally such as e-Learning, e-News e-books and e-Government (Charmonman and Chorpothong, 2005).

This study is inspired by Alive and Kicking's start-up and ongoing activities as a charity that makes sports balls in Africa, and how it has adopted the Lean Start-up principles in its growth. Alive and Kicking (A&K) is a Social Enterprise that manufactures balls in Kenya, Ghana, and Zambia to

meet its objectives of providing balls for kids, jobs for adults and health awareness through sport (Ellarby, 2013). In the 21st century, social enterprise, broadly defined as businesses that trade for social purposes, has attracted considerable policy interest within the western world and beyond (Defourny and Kuan 2011; Kerlin 2009). Therefore, the researchers are going to explore how to empower the youth who are school dropouts through online income generation of social enterprise initiatives in Malaysia.

During the last five years, Otto-Rieke (2010) states that two out of three businesses in Germany work with a travel agency via online applications. Online offerings have gained market share in this sector, with standard services increasingly found and booked on the Internet. As travel volume rises, so does the potential for saving costs. While half of small- to medium-sized enterprises do without the services of a travel management company, 84% of businesses with over 1,500 employees do take advantage of such services (Otto-Rieke, 2010). Therefore, this could be a potential sector for the dropouts to generate income in Malaysia too.

The movement from free-market economics towards responsible entrepreneurship reflects the changing cultural context and interactions between society and entrepreneurship. The shift towards socially responsible entrepreneurship, accountable to society, reflects ethically and environmentally sustainable values (Rae, 2010). According to Burégio, Maamar and Meira (2015), a Social Enterprise architecture must be strongly coupled with Web 2.0 technologies to support the enterprise in reaching out to stakeholders, including customers, suppliers, competitors, and regulatory authorities. Unknown people (such as discussion group members) can also be stakeholders and can thus interact with the Social Enterprise. This is not the case with traditional (that is, non-social) enterprises, in which stakeholders must be known in advance (Burégio, Maamar and Meira, 2015).

The characteristics of new entrepreneurship such as social entrepreneurship clearly can be acknowledged due to its structure. Rae (2010) states that social entrepreneur has individual-team leadership within a social context; opportunities create multiple forms of value: financial, creative, social, ecological, socially connected and networked; collectivist and inclusive; ethically responsible, economically and environmentally sustainable; sensitive to resource stewardship; conservation and re-use; longer term sustainable growth and development; feminine

values: relational, collaborative, intuitive working which complement; masculine attributes of competition, and grassroots enterprise and resourcing.

The media environment is constantly evolving in the content which youth are exposed to and in the way this content is delivered. The new media forms such as chat rooms, E-mail, and many sites on the Internet demand interaction with the user, more engaging as the consumers will be able to step into virtual worlds in which their whole bodies, not only their eyes and ears, are involved (Brown and Cantor, 2000). Unfortunately, today's children and adolescents have been discovered as a lucrative commercial market segment where media can be used to persuade youth and affect their behavior (Brown and Cantor, 2000) and this including the school dropouts. Consequently, through the Social Enterprise, this study wants to encourage the school dropouts to take the opportunities of digital life styles to generate income without putting any barriers of the education background, age, gender, race, capital and geographical areas.

II CURRENT ISSUES

In the primary schools, students are taught to master basic skills of reading, writing and calculating, while and scientific skills are promoted (Ministry of Education Malaysia, 2011a). Primary School Achievement Test (UPSR) is the first public examination taken by students at the end of Year 6 to see how far their achievement in acquiring the basic skills of writing, reading and mathematics before they move into secondary education (Othman & Md Salleh, 2005). There are five compulsory subjects tested in the UPSR -- Malay Language Comprehension, Malay Writing, English, Mathematics and Science subjects, while Chinese and Tamil are offered at the National Type Primary School (SJK). However, there are still a small number of students who left school because of their lack of interest in education. The percentage of dropout students in Primary School stage which follows the school system under Ministry of Education for the period 2006 to 2010 was at a rate of 1:32 percent (Wee, 2011).

Studies conducted by Rasinski and Pedlow (1994) find that vocational education can reduce the dropout problem. This effort coincides with implementation of Basic Vocational Education which provides opportunities for Year 6 leavers who fail to reach minimum achievement-oriented academics to remain in the school system where they will acquire within their means, interests and

potential some capabilities in the field of vocational training (Ministry of Education, 2011c). Basic Vocational Education program is introduced and implemented generally to prevent student dropouts at primary and secondary levels due to various factors such as slow learner, disciplinary problems, delinquency, socio-economic problems, and so on. It is designed to produce human capital that is skilled, critical, creative and innovative through the environment-oriented learning experience of the working world. Curriculum undertaken also led to the construction of identity, competence development and development of entrepreneurship vocational skills competency. Muhamed (2012, January 4) also believes that not all students are academically inclined and skilled students need to be trained in order to produce more skilled workforce. Vocational education with the right skills is a key element in any strategy to reduce the problem of low achievement among students (Cassen and Kingdon, 2007). However, the other challenge is when these dropout students are neither interested in academic nor vocational. They cannot stay focus in the classroom setting or workshop. They want to work only when they need the money. The rest of their time, they like to spend time playing futsal or hang around in the shopping complex with friends.

This study aims to understand the issue of school dropouts in Malaysia and explore the avenues for their income generation through digital lifestyle that is prevailing in society. The study is expected:

- a) To assist youth in self-empowerment through Social Enterprise.
- b) To contribute towards improving the existing policies on youth.
- c) To provide a model of financial education to citizenry especially the young people through Social Enterprise.

The changing nature of entrepreneurship is an outcome of a process of learning and adaptation. Rae (2010) suggests that educators play a major role in defining and informing the new entrepreneurship through research, innovative learning and co-creation of knowledge with new era entrepreneurs. He believes, to understand the new entrepreneurship such as social entrepreneurship, it is important to relate it to different contexts of how people learn, innovate and develop new era enterprises, and what new business models they develop to create value. There is increasing convergence between 'mainstream' entrepreneurship as it moves towards the new era paradigm and social entrepreneurship,

which has informed and created new insights into the potential for responsible entrepreneurship (Rae, 2010).

Many entrepreneurship programs have been developed as an intervention mechanism in promoting youth entrepreneurship (Awogbenle and Iwuamadi, 2010). Among the focuses of the programs are creating employment opportunities for self-employed youth as well as the other young people they employ; bringing alienated and marginalized youths back into the economic mainstream and giving them a sense of meaning and belonging; helping to address some of the socio-psychological problems and delinquency that arise from joblessness; helping youths develop new skills and experiences that can then be applied to other challenges in life; promoting innovation and resilience in youth; promoting the revitalization of the local communities by providing valuable goods and services; and capitalising on the fact that young entrepreneurs may be particularly responsive to new economic opportunities and trends.

In the United States of America, the advocates of positive youth development have argued that participation in organized activities facilitate optimal development and therefore policymakers should provide more opportunities for American youth to be involved in such activities (National Research Council and Institute of Medicine, 2002). With reference to that, the researchers strongly believe that this study will succeed with the significant support from Fulbright programs which had been active for decades around the world. And now with the full support from Malaysia Communication and Multimedia Commission (MCMC) – Fulbright grant, the study will facilitate positive adjustment in our dealing with the problem.

From the study finding, it is the intention of the researchers to introduce an outreach program that will help the school dropout youth to acquire self-empowerment, financial literacy, and become good citizens. With heightened interest in opting for Social Enterprise around the world, Malaysian authorities such as Ministry of Education, Ministry of Youth and Sports, and Ministry of Human Resource must have a master plan to deal with this challenge in transforming the school dropouts to become digital entrepreneurs. New business paradigms and models can only be initiated if policy makers themselves have the appropriate knowledge and exposure, and understand the competitive advantage of Social Enterprise over their traditional business competitors.

III RESEARCH METHODOLOGY

Social science researchers continue to use the tried and true methods of social psychology and sociology such as content analysis, surveys, and experiments when conducting researches (Brown and Cantor, 2000). However, the evolving media environment and digital civil society require that these methods be adapted to accommodate what we have come to know about the processes being studied and the difficulties in studying some of these phenomena such as Social Enterprise using standard methods (Brown and Cantor, 2000).

This study adapts qualitative approach and analysis to explore how the school dropouts perceive the digital civil society, financial education and Social Enterprise as a mode of income generation. At the end of the day, they can be a good citizenry and contribute in helping other dropouts. Furthermore, variations in Social Enterprise around the world are in part due to their connection with specific socioeconomic conditions within their context (Kerlin, 2009).

When studying the Social Enterprise in Spain, Moreno-Romero (2015) has implemented Kerlin's institutional framework (2013) that analyzes the five major elements that influence the conformation of country-level Social Enterprise models: A rich mix of cultural, local, regional and global hierarchies (including social classes) and political-economic histories, the type of government, the stage of economic development, the model of civil society and international influences.

In this study, the five major elements in Kerlin's Social Enterprise framework would be used to guide the researchers to construct the open-ended semi-structured questions when conducting individual interviews and focus group discussions. It also involves close engagement with Social Entrepreneurship, Social Innovation and Digital civil society learning during this period. This study is exploratory and reflective informed by multiple discourses of Social Enterprise from policy, education, media and practice where the researchers are acting as a speaker, educator, reviewer of refereed papers, and engaged participants working with right financial educators, entrepreneurs and business support professionals. As a cultural movement, Social Enterprise is manifested in such discourses, which make explicit significant governing ideas, concepts, phrases, assumptions and values. Among the factors to the discourse included are political and government policy, close-to-government organizations, academic research, and

other Social Enterprise entities in Malaysia. Direct engagement with school dropouts and entrepreneurs at educational, networking events and other encounters should also contribute to this study.

Table 1. Details of the Research Methodology Process

Initial Research Design	i. The researchers study previous researches on the topic from the literature reviews. The study is designed to ensure the data can be collected from the right samples.
Data Collection	<ul style="list-style-type: none"> i. A focus group discussion will be conducted with 10 participants who are school dropouts in each session in order to understand the real issue. From the school dropouts in the focus group discussion, the researchers shall use snowballing sampling to identify other participants for individual interviews. ii. Focus group discussion shall also be conducted with participants specially chosen from the related agencies with the knowledge and information on school dropouts. iii. The data from related agencies and Ministries will be used to understand the sample. This information will be used to triangulate and support this study's objectives. iv. The researchers will repeat the same focus group discussion and interviews with the participants in USA..
Expert Reviews	<ul style="list-style-type: none"> i. Experts shall be drawn from Malaysia and USA. ii. Later, the researchers will conduct two focus group discussions with successful Social Enterprise in USA and interview the experts in USA in order to understand and learn how they do it successfully with the school dropouts. The researchers are interested to explore what drives dropouts in USA to generate income through digital initiatives while encouraging social enterprises locally.
Data Analysis	<ul style="list-style-type: none"> i. This is a very important part. The researchers' knowledge, expertise and experience must be solid to interpret the data and construct the findings. ii. The researchers seek to understand the phenomena (Social Enterprise) in context-specific setting (digital civil society). iii. The quality of the study must be based on data rigorousness, validity and reliability, credibility, transferability and trustworthiness to reflect the interpretivist (interpretivism) conceptions. iv. Triangulation is a strategy used in order to control bias and establishing valid propositions because traditional scientific techniques are

	incompatible with this alternate epistemology.
Conclusion	i. All the data being collected from Malaysia and USA will be triangulated during the analysis process. The theme emerged from the data will be interpreted and a proposed Social Enterprise model will be constructed for school dropout further development.

Brown and Cantor (2000) propose that research conducted with the public interest in mind, such as this study on school dropouts, should be peer-reviewed, critiqued, and made accessible in a timely way to all stakeholders, including other researchers, parents, teachers, youth service workers, and policy makers. The researchers hope this study would help especially the young school dropouts in the development of their economic self-reliance through digital social enterprise activities. This not only complemented the efforts of government in educating good citizenry, but also contributed toward promoting positive digital civil society among the youth.

This study is current, very critical and cannot be ignored as its potential impact is huge on the economy as well as political stability of the country. The dropouts might not have good formal education, degree or qualification, but in today's scenario where digital civil society is the trend, they can lead their lives comfortably, healthily while distancing themselves from criminal activities. They are generally exposed to the Internet and mobile applications despite their family's economic difficulty which denies them ready access to the technology. However, they must be taught on how to empower themselves with the talents and skills that they could acquire, and from there, proceed seriously to improve themselves. Social enterprise and financial education could significantly help dropout youths to generate income and thereby improve their livelihood.

IV CONCLUSION

As of now there is no legislation (Act) on Social Enterprise in Malaysia that could guide the process of promoting this outreach program compared to, for example, Australia (Barraket, 2015), Spain (Moreno-Romero, 2015), United States of America and United Kingdom (Sepulveda, 2014). The findings of Barraket's study (2015) show that Australian social enterprises are less likely to see public investment in core services, which is a contrast to other countries, such as the United Kingdom, where in the recent past government commitments to 'growing' social

enterprises were seen as concomitant with public sector spending. Youth are surrounded by media environment with the massive exposure to the same kind of content in their everyday lives (Brown and Cantor, 2000). For that reason, the researchers believe that communication and multimedia industry in Malaysia specifically and globally in general could provide a platform for the dropouts to generate income by assisting in:

- a) appropriate channels and skills training for the dropouts through mobile application access point,
- b) financial education exposure through business model canvas workshop for the dropouts,
- c) social interaction where dropouts can be trained to have entrepreneurial mind and attitude, and

The long-term attitude or behavioral change, rather than short-term effects, is often the true focus of this research interest, rendering the research design incapable of uncovering the all important impact of culture, education systems and implementation (Brown and Cantor, 2000). For these reasons, the researchers anticipate the need for more longitudinal, observation and participatory studies that look at multiple media sources (such as smart phone, desktop and laptop) in digital civil society and how the dropouts manage their self-empowerment.

REFERENCES

- Awogbenle1, A. C., & Iwuamad, K. C. (2010). Youth unemployment: Entrepreneurship development program as an intervention mechanism. *African Journal of Business Management*, 4(6), 831-835.
- Azmi, N. I., & Hashim, M. H. M. (2014). Penerapan Pembelajaran Sepanjang Hayat Melalui Pelaksanaan Pendidikan Asas Vokasional. Retrieved July 31, 2015 from http://eprints.uthm.edu.my/3394/1/Penerapan_Pembelajaran_Sepanjang_Hayat_Melalui.pdf.
- Barraket, C. M. J. (2015). Understanding Social Enterprise model development through discursive interpretations of Social Enterprise policymaking in Australia (2007-2013). *Social Enterprise Journal*, 11(2), 1-24.
- Brandsen, T., Larsson, O.S., & Nordfeldt, M. (2012). Local welfare from a historical and institutional perspective: a comparative report. (No. 12/01): EMES Research Network.
- Brown, J. D., & Cantor, J. (2000). An agenda for research on youth and the media. *Journal Of Adolescent Health*, 27, 2-7
- Burégio, V., Maamar, Z., & Meira, S. (2015). An Architecture and Guiding Framework for the Social Enterprise. *IEEE Internet Computing*, 64-68.
- Cassen, R. & Kingdon, G. (2007). Tackling Low Educational Achievement. Joseph Rowntree Foundation.
- Charmonman, S., & Chorpothong, N. (2005, November 19-20). Digital Lifestyle and the Road Ahead. Proceedings of the Fourth International Conference on eBusiness, Bangkok, Thailand.
- Defourny, J., & Kuan, Y.-Y. (2011). Guest editorial: are there specific models of social enterprise in Eastern Asia? *Social Enterprise Journal*, 7(1), 5-8.
- Ellarby, P. (2013). Balls for Africa. *Agile Conference*, 150-155.
- Kementerian Pelajaran Malaysia (2011a). Pengumuman Analisis Keputusan Ujian Pencapaian Sekolah Rendah (UPSR) Tahun 2011. Putrajaya: Lembaga Peperiksaan Malaysia.
- Kementerian Pelajaran Malaysia (2011b). Kertas Cadangan Bil. 4/2011, Mesyuarat Jawatankuasa Kurikulum Pusat. Putrajaya: Bahagian Pendidikan Teknik dan Vokasional.
- Kementerian Pelajaran Malaysia (2011c). Panduan Pelaksanaan Rintis Pendidikan Asas Vokasional. Putrajaya: Bahagian Pendidikan Teknik dan Vokasional.
- Kerlin, J. (2013). Defining Social Enterprise across different contexts: a conceptual framework based on institutional factors. *Nonprofit Voluntary Sector Quarterly*, 42(1), 84- 108.
- Kerlin, J. (2009). *Social Enterprise: A Global Comparison*. Lebanon, NH: University Press of New England.
- Lee, K. W. (2003, August 25-27). Low Power Requirements for Future Digital Life Style. Proceedings at the ISLPED '03, Seoul, Korea.
- Mahoney, J. L., Harris, A. L., & Eccles, J. S. (2006). Organized Activity Participation, Positive Youth Development, and the Over-Scheduling Hypothesis. *Social Policy Report, Giving Child and Youth Development Knowledge Away*, XX(IV), 3-32
- Malaysian Communications and Multimedia Commission, Hand Phone Users Survey 2014, Statistical Brief Number Seventeen
- Mohd Dom, A. (2009, November 19). Pencapaian UPSR Meningkatkan. Retrieved 25 July 20, 2015 from <http://www.mstar.com.my/>
- Moreno-Romero, R. F. A. (2015). Understanding Social Enterprise country models: Spain. *Social Enterprise Journal*, 11(2), 1-22.
- National Research Council and Institute of Medicine. (2002). Community programs to promote youth development. Committee on Community-Level Programs for Youth. J. Eccles & J. A. Gootman (Eds.), Board on Children, Youth, and Families, Division of Behavioral and Social Science and Education. Washington, DC: National Academy Press.
- Othman, I. & Md Salleh, N. (2005). *Kurikulum dan Pengajaran Sekolah Rendah: Aspek-Aspek yang Berkaitan*. Tanjong Malim: Quantum Books.
- Otto-Rieke, G. (2010). What's Hot in Business Travel Management? In R. Conrady & M. Buck (Eds.), *Trends and Issues in Global Tourism 2010*. Heidelberg Dordrecht: Springer.
- Rae, D. (2010). Universities and enterprise education: responding to the challenges of the new era. *Journal of Small Business & Enterprise Development*, 17(4), 591 – 606.
- Rasinski, K. A., & Pedlow, S. (1994). Using Transcripts to Study the Effectiveness of Vocational Education. *Journal of Vocational Education Research*, 19, 23-43.
- Sepulveda, L. (2014). *Social Enterprise – A New Phenomenon in the Field of Economic and Social Welfare?* London: John Wiley & Sons Ltd.
- Tan Sri Murad Mohd. Nor. (1988). *Pengkisahan Sejarah Pentadbiran Malaysia - Perkhidmatan Awam 1957-1970*. Retrieved July 30, 2015 from <http://www.arkib.gov.my/web/guest/tan-sri-murad-bin-mohd.-noor>.
- Taylor-Smith, E., & Lindner, R. (2009). Using Social Networking Tools To Promote eParticipation Initiatives, *Social Networking Tools and Widgets*. Retrieved July 20, 2015 from <http://www.researchgate.net/publication/241393198>.
- Wee, K. S. (2011). Kementerian Pelajaran Lakukan Kajian Keciranan Murid. Retrieved July 2, 2015 from <http://mynewshub.my/>.

Skills and Competitiveness for Poverty Reduction in Northeast, Thailand by Enhancing Knowledge Management in Capacity Building Framework

Thossaporn Thossansin

Rangsit University (RSU), Thailand, thossaporn@rsu.ac.th

ABSTRACT

This research aims to study on skills and competitiveness for poverty reduction in northeastern Thailand in order to improve the competitiveness of the Northeast and increase the quality of human resources with a use of ICT. The study found that students' competency in using the IT tools was significantly lower than what is required by employers, which might be one of the major factors that has limited the opportunities for students in obtaining jobs in their local region, as was also indicated in the findings. A need to design a curriculum and teaching strategies that maintain students' frequent use of computers and the Internet with a view to completing course assignments is urgent, when considering the relatively less frequent use of computers and the Internet reported by the students in the present survey. Furthermore, the training sessions, formulation of a virtual community that involves teachers in the Northeast region of Thailand is recommended. The community enables participating teachers to maintain and expand their knowledge and network after the training and give support in development of knowledge management (KM) contents, which would encourage them to improve the level of education in the region through the corporative projects.

Keywords: Competitiveness, poverty, knowledge management, capacity building framework.

I INTRODUCTION

An interim report of productivity analysis of skill delivery institutions from the World Bank (Foresight Research, 2014) has evidenced that recovery from the poor productivity performance of Thai firms as well as gaps in international competitiveness is an urgent demand on the Royal Thai Government. In particular, the high concentration of poverty in the Northeast region of Thailand requires improvement in its competitiveness. Findings on the previous research on factors that are impacting on students' competency in IT skills are reviewed. Based on his case studies on a number of early childhood, high

school, and university classrooms in the United States, Cuban argues that investment to increase the number of computers as well as Internet access does not necessarily improve academic learning and prepare students for an information-based workplace (Cuban, 1993; Cuban, 2013). It can be highlight the importance of the school's schedule and equipment that allow students to work on computers on a daily basis.

The positive association between students' frequent technology use and their academic achievement has been evidenced by previous research (e.g., Bussière & Gluszynski, 2004; O'Dwyer et al., 2014). A number of researchers have supported this argument. The percentage of students using the Internet on a daily basis was nearly the same as that of Vitartas and Sangkamanee's (2012) research conducted on 170 students studying at an international university in Bangkok. It is reasonable to assume the percentage of students accessing the Internet at least once per day may be much higher now. Information and Communication Technology (ICT) has become an important role in both society and community. Thai citizen allows to access unlimited useful data and resources by using ICT. This creates a new mechanism to expand knowledge network for their community (Sutasinee, 2014).

Generally, the purpose of this research is to improve the competitiveness of the Northeast by building skills to increase the quality of human resources with a use of ICT. The current Skills and Competitiveness for Poverty Reduction in Northeast Thailand is an approach to improve the competitiveness and thus reduce the poverty of the region of Northeastern Thailand with a use of ICT.

II METHODOLOGY OF THE RESEARCH AND ANALYSIS PROCESSES

A. Participants

For the institution survey, a total of 180 colleges and universities that had vocational programs located in the Northeast region of Thailand were selected. For the employer survey, a total of 60 organizations were selected for the survey. Criteria of the selection were: (a) located in one of the 19 provinces in the Northeast region of Thailand, and (b) at least 90

percent of employees had to have completed their education in the Northeast region of Thailand. Finally, a total of 200 students studying at either one of the educational institutions that participated in the institution survey responded to the student survey.

B. Instruments

Prior to a development of the questionnaire, the survey team conducted interviews with two education commission offices in Bangkok (i.e., the office of the higher education commission and the office of the vocational education commission) and six educational institutions located in the target region. Based upon the interview data, the survey team members developed the questionnaire.

C. Procedure

Prior to the data collection, the survey team visited the selected participants to explain the purposes and significance of the survey and request their participation. At the same time the team sent official letters to those institutions and organizations requesting participation. On agreement with the institutions, the team arranged times and dates for the interview. Prior to the interview, the team provided the questionnaire form to the institutions and organizations so that they could prepare for it by obtaining information that their responses were based upon and filling a part of the questionnaire that requested numerical responses. A trained member of staff visited each participant on the appointment date and interviewed the representative of the institution and a student recommended by him or her, or the representative of the organization. Numerical responses on the survey forms completed by the representative were first entered onto excel files by the admin team.

D. Analysis Processes

For the quantitative data, descriptive statistics were analyzed to examine characteristics of responses. ANOVAs and T-tests were used to contrast groups. Correlations were calculated in order to find any meaningful relationships between variables of interest. Multiple regression analysis was performed to find a linear relationship between the criterion variable and its predictors.

III SUMMARIZED RESULTS OF THE SURVEY (QUANTITATIVE AND QUALITATIVE)

A following is a summary of the major findings.

A. Institution Survey

A total of 180 colleges and universities that had vocational programs located in the Northeast region of Thailand were selected for the present survey. Among those 180 institutions, 129 (45%) were vocational colleges, 30 (43%) were regular colleges

and universities, and 21 (11%) were community colleges.

Size of institutions: regular colleges and universities appeared to have a higher number of students and instructors than did the other types of institutions; however, the student-instructor ratio did not differ among institutions.

i. E-learning

Over 90 percent of regular colleges and universities, and nearly a half of vocational and community colleges had offered E-learning course(s). E-learning courses were most likely to be developed by the course instructors.

Factors that prevented institutions from offering e-learning courses: institutions that had not been offering e-learning courses were significantly lower than their counterparts on levels of budget, hardware, Internet access, instructors' skills and motivation for teaching e-learning courses, and students' skills for learning through e-learning courses. In particular, budget was significantly lower for institutions that had no plans for offering the e-learning course than those that had not offered e-learning courses but had plans to do so in the future. As it can be shown in Figure 1

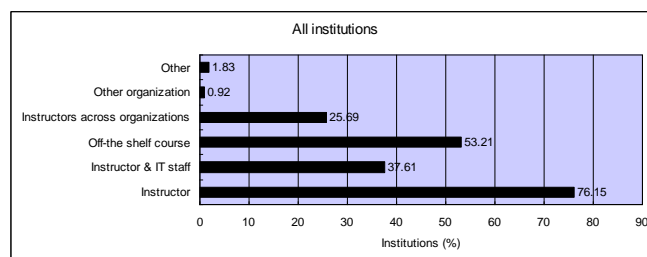

Figure 1. Sources of E-Learning Courses.

Note : (from bottom)
 Instructors fully developed courses.
 Instructors and IT staff developed courses.
 Instructors purchased off-the shelf courses.
 Instructors at the institution and from other institutions developed courses.
 Used courses developed by other organizations.
 Other.

ii. Employment

Overall, a half of the students who were employed after graduation stayed in the Northeast region, while less than 40 percent of them moved to Bangkok.

Effective sources for obtaining a job: institutions reported that career placement center (CPC) and training programs such as Co-op training program (CTP) and Dual vocational training program (DVTP) were less effective sources for getting jobs than students' directly approaching employers and medium such as information available on newspapers and the internet. It can be summarized in Figure 2.

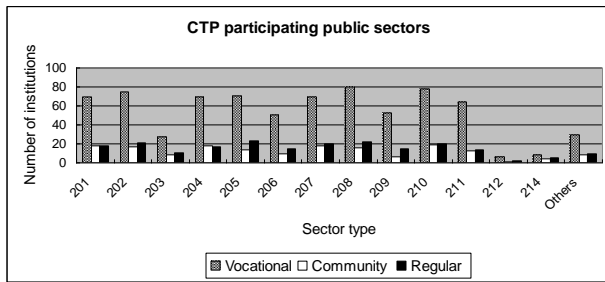

Figure 2. Types of CTP participating organizations for vocational colleges, regular colleges and universities, and community colleges (Public sectors).

Note: 201: State bank 202: State hospital 203: Public health care 204: Cooperative store 205: City hall 206: Court 207: District office 208: Local administrative office 209: Electrical generator authority 210: Provincial electrical authority 211: Provincial water authority 212: Telephone organization of Thailand 214: State educational institution

B. Employer Survey

A total of 60 organizations that were located in the target region and having at least 90 percent of employees who completed their education in the target region. A half of them were in the private sector (n = 32), and the other half consisted of government sectors (n = 14) and state enterprises (n = 14).

1. Type of gender that the organizations employed. The following patterns were commonly found among all three sectors: nearly half of the positions were currently open to both males and females. Regarding positions that were limited to either males or females, currently more were for males than for females.

2. Positions that was open to both males and females would be increased in the future; however, they would still remain less than 60% of the total positions available.

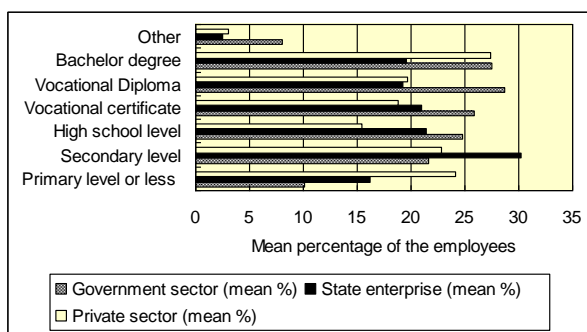

Figure 3. Employees' Education Level for Each Sector Type (%).

C. Student Survey

A total of 200 students studying at the educational institutions that participated in the institution survey responded to the present survey. Among those 200 students, 136 (68%) were from vocational colleges, 42 (21%) were from regular colleges and universities, and the rest of 22 (11%) were from community colleges.

The main purpose of the survey was to draw comparisons to find gaps among institutions, employers, and students.

1 Competitiveness in autonomous learning skill and other critical skills:

- Skills those students and institutions estimated equally, but significantly lower than did organizations: interpersonal skills

- Skills in which students expected to achieve significantly higher than the current levels reported by the institutions (both were significantly lower than what employers required): problem solving, responsibility, and leadership

2 Skills that students expected to achieve to the level of what the employers required: autonomous learning skills and foreign language skills. It can be categorized type of student's skills and in Table 1

Table 1. Comparisons of Means and Standard Deviations on the Degree of Perceived Levels of Students' Competitiveness. Note: Degree of consideration differs from 0 (poor) to 10 (excellent).

Type of Skill	Institutions (n = 179)	Employers (n = 60)	Students (n = 200)	F values
Autonomous learning skill	7.62 _a (1.54)	8.75 _b (1.43)	8.28 _b (1.32)	17.21 p = .000
Interpersonal skill	8.03 _a (1.26)	8.97 _b (1.43)	7.83 _a (1.74)	12.99 p = .000
Knowledge and skill in concentration	8.20 (1.28)	8.50 (1.53)	8.03 (1.64)	2.50 n.s.
Problem solving skill	7.46 _a (1.50)	8.60 _b (1.54)	7.95 _b (1.53)	13.36 p = .000
Foreign language skill	5.89 _a (1.72)	6.90 _b (2.30)	6.67 _b (2.12)	9.20 p = .000
IT / computer skill	7.86 (1.76)	8.37 (1.67)	7.77 (1.79)	2.72 n.s.
Responsibility	8.09 _a (1.28)	9.27 _c (1.22)	8.57 _b (1.43)	18.27 p = .000
Leadership	7.48 _a (1.44)	8.85 _c (1.26)	8.25 _b (1.66)	21.80 p = .000

D. Major Areas for Action

After reviewing and analyzing the results of institution, organization and student surveys, we found that the major areas that brought the most attention are;

1. Areas with High Job Market Demand

The study shows that presently organizations have a high demand for employees with an educational background in Accounting/Accounting software, Computer/Computer for Business, and Business. This finding is in line with the study result which shows that there is also a high demand for academic study in these areas: Accounting/Accounting software, Computer/Computer for Business. The study also indicates that in the future there will be a high demand for employees with qualifications in Computer/Computer for Business, Business and Marketing. Computer qualifications continue to be in high demand in the job market because computers are playing a significant role in various areas of business: accounting, human resources management, and inventory management. The

current education system, however, does not encourage the development of students' computer skills because it focuses mainly on theory, not on hands-on practice. In addition, most computer classes are lecture-based for which instructors use computers solely as class presentation tools but not for students' hands-on practice. This ineffective computer teaching method therefore reduces students' enthusiasm to use computers for self-learning.

2. Practical Training

The study reveals that institutions have three types of practical training program: Co-Op Training Program, Dual Vocational Training Program, and Non-Student Training Program. In general, organizations are only involved in specifying training schedules and in identifying students' assessment criteria. They are hardly involved in designing the training programs. The lack of active participation in designing training programs generally generates poor training results: student trainee's end up performing work in the areas out of their concentrations. This mismatch of qualifications has therefore made organizations mistakenly perceive that students lack adequate knowledge and analytical skills to perform the assigned work.

3. IT Utilization

The study shows that most organizations are using computers, especially basic software and accounting software, for their businesses. Their staff members are very skillful with basic computer software such as MS Office, but they hardly ever use other advanced software programs due to the lack of skills. Like most employees at organizations, students are very competent in basic computer software and lack other advanced computer skills.

Institutions still do not widely use E-learning in teaching and learning because of the limitation on support equipment and funding. The teaching method commonly used at institutions is of a lecture type. E-learning poses some concerns over student learning effectiveness: students may not be able to follow E-learning lessons well, in which case they will lose their enthusiasm, and their study performance will be affected. These concerns are tied to Thai culture. Thai people do not like to learn by themselves, when there is no one around to control their learning process, and they prefer doing enjoyable, entertaining and fun activities. Therefore, it would be difficult to persuade them to sit down and learn by themselves via E-learning, with all lesson content the same as is taught in class. Although E-learning can encourage self-development in students, lack of sufficient

interactive and interesting E-learning programs and close follow-ups from instructors will affect students' perception towards E-learning and their ability to use it in the future. Institutions in fact view E-learning as useful, but they lack enough funding to support it.

For the Internet, nearly half of the students from the regular colleges and universities (20 out of 42 students) and vocational colleges (66 out of 134 students) and about 63 percent of the community college students (14 out of 22 students) used it not on an everyday basis, but two or three times per week (see Table 2). Only about 17 percent of the vocational college students (23 out of 134 students), 24 percent of the students from the regular colleges and universities (10 out of 42 students), and 14 percent of the community college students (3 out of 22 students) reported to use the Internet on an everyday basis.

Table 2. Numbers and Percentages of students using the Internet
Note: Percentage refers to that of students out of those from the corresponding type of institution

	Vocational (n = 136)	Regular college and university (n = 42)	Community college (n = 22)	All (n = 200)
Use the Internet:				
Every day	23 (17.16)	10 (23.81)	3 (13.64)	36 (18.18)
2 to 3 times a week	66 (49.25)	20 (47.62)	14 (63.64)	100 (50.51)
Once a week	14 (10.45)	9 (21.43)	5 (22.73)	28 (14.14)
2 to 3 times a month	12 (8.96)	1 (2.38)	0	13 (6.57)
Once a month	8 (5.97)	2 (4.76)	0	10 (5.05)
Do not use	11 (8.21)	0	0	11 (5.56)

IV CONCLUSIONS

This research indicated that how many of the school computers were equipped with the Internet connections as well as how many of the school computers were available for classroom use accounted for the competency in using IT tools to some extent, but there might be more important factors to be considered.

In order for participants of the current workshop sessions to retain and improve knowledge and skills that they have acquired through the session, it is necessary to provide further training sessions in the future. Those sessions should include the following two skills in addition to those in the current sessions: prerequisite skills that are necessary for the mastery of the succeeding courses, and skills to apply what the participants have learned through the current sessions to create effective knowledge management contents and online course.

A demand for providing the prerequisite skills' training comes from the finding in which a large number of teachers did not have sufficient skills for using the computer. It is recommended that those prerequisite training sessions target skills that are necessary for teachers to use the computer at work, including: (a) operating the computer (e.g., using a keyboard and a mouse quickly and appropriately,

becoming familiar with the fundamental computer terms, creating folders and managing files, and navigating on the Windows); (b) using tools on the Internet (e.g., sending and receiving e-mails with or without attachments, using the search engine to find information, browsing websites, and downloading the target files); and (c) using the major applications including Word, Excel, and PowerPoint. Those skills are not only required for the mastery of the skills and knowledge that were provided in the current training, but also should be helpful for teachers to prepare instruction and to efficiently manage knowledge sharing and the administrative work. Furthermore, for each type of training, it is necessary to provide opportunities for participants to: monitor their learning after the completion of each session, and practice in the classroom on their own with the assistance of the instructor as is necessary. More importantly, training for instructors to direct the project-oriented group work is needed in order for each course to be more effective, and for the trainers to be able to apply the format to their own instruction.

Finally, in addition to the training sessions, formulation of a virtual community that involves teachers in the Northeast region of Thailand is recommended. The community enables participating teachers to maintain and expand their knowledge via understanding a knowledge management process and network after the training, which would encourage them to improve their level of education in the region through cooperative projects.

• **Policy Recommendation**

Even though the assessment project is completed, but there are several processes that the Ministry of Information and Communication Technology (MICT) should put in place as part of the policy development. There are several improvements that could be made to enable a strategic vision to be developed for effective e-learning practices. This recommendation has five related parts:

1. Utilizing the analysis of the research findings

The MICT should provide support by any means to assist all trainees to be able effectively to identify, acquire, and integrate learning objects that they have learned from the training programs of the project. By doing so, this will be achieved through a combination of enhanced professional development activities including digital resources and the ongoing support of e-learning specialists. The MICT should continue undertake and support projects for e-learning in conjunction with the local government and the private sectors in order to secure the

sustainable production, acquisition, and maintenance of learning resources.

2. The capacity building program

It can be seen that the project provides training as a support for the people creating and using e-learning systems for the human resource development of the Northeast of Thailand. A crucial success factor for e-learning usage is the adopted to implement on the improved learning by the trainees The MICT should expand its training and support programs, directly targeting all users of e-learning systems. The private sectors involved in IT businesses and related fields should be included in these training sessions and support programs. The re-training programs should be provided to include pedagogical design support and discipline-specific design. In addition, a significant focus on effective use of technology needs to be considered to enhance the context of effective pedagogy.

3. IT Utilities and E-learning Environment

It is recommended that MICT should provide better IT utilities and e-learning environments for all schools in the NE of Thailand on an “equal-opportunity basis.” The assessment confirmed that about half of all students leave NE Thailand upon graduation for work elsewhere and those that graduated were not as well prepared in terms of ICT skills as the educational institutions thought. Students were shown to be lacking in ICT and foreign language skills in particular, and specifically within the ICT skills set, the weakest skills were in more technical areas where there is growing demand for labor, such as accounting and software development. The report also pointed to an educational system that was relatively unequipped to use and facilitate student learning through ICT tools, but those schools that were well-equipped with computers, internet connections, etc. had better prepared students. The schools appeared to be most in need of the appropriate hardware, software, and maintenance of their IT systems, but the level of instructional readiness was viewed as strong. In addition, over 90% of the colleges and universities, and over 50% of vocational schools were using e-learning courses, but they were not active programs. Finally, the other interesting finding was that students found that open sources (i.e., internet, newspapers, etc.) were more effective at finding jobs after graduation than the schools or the on-the-job training programs.

4. Knowledge Management and Knowledge Sharing

It can be found an initiative teacher who can be multiply his knowledge and sharing with other teachers. Developing their performance and

processes. In this regard, knowledge management (KM) processes have turned out nowadays to become a strategic resource to the extent in which KM is viewed as a base of success or failure. It may need a policy in place to foster the flow of knowledge among teachers. Moreover, a successful knowledge management system is a shared system where teachers can retrieve and contribute to the knowledge pool as well (Meng, H., Chun, M., 2014).

5. IT infrastructure

The sum total of the aforementioned issues points to various possible policy reactions from MICT and the Government. The most obvious one would be to establish facilities to help the schools make the necessary investments in the IT infrastructure. Secondly, the findings reveal a need for a renewed emphasis on training in the core skills areas demanded in the local economy and finding new ways to use e-learning tools and knowledge management contents to access the best knowledge available to develop those skills among students. Third, a more systematic approach to linking the employers with the schools should be found to encourage better targeting of on-the-job training programs and courses that are more applicable to the job market. Finally, linkages by the schools to the open source job search websites, companies, etc. should be made to link the job seekers (students) to the employers, as well as to provide the schools with a better idea of the skills demands in the market.

The above recommendation should be considered as it is feasible. This study indicated that the most important is to multiply number of train the trainers as well as develop e-learning and knowledge management contents. Teachers can deploy their contents at any prefer time. Moreover it needs to encourage teachers to see the real benefits of e-learning and knowledge management process.

REFERENCES

- Badenhorst, J. J. C. and de Beer, K. J. (2014). Blended Learning at the Central University of Technology, Free State.
- Becker, H. J. (2014). Findings from the teaching, learning, and computing survey: Is Larry Cuban right? *Education Policy Analysis Archives*, 8(51).
- Bennett, S. (2013). Supporting collaborative project teams using computer-based technologies. In T. Roberts (Ed.), *Online collaborative learning: Theory and practice*, (pp. 1 – 27). Hershey, PA: Idea Group Inc.
- Brown, A., & Campione, J. (2013). Guided discovery in a community of learners, In K. McGilly (Ed.), *Classroom lessons: Integrating cognitive theory and classroom practice*. Cambridge: MIT Press.
- Brown, C. J., & Fouts, J. T. (2013). Michigan technology integration training initiative: Michigan virtual university Michigan association for computer users in training. Seattle, WA: Bill & Melinda Gates Foundation.
- Brussière, P., & Gluszynski, T. (2014). The impact of computer use on reading achievement of 15-year-olds. Learning Policy Directorate, Strategic Policy and Planning Branch, Human Resources and Skills Development Canada. Quebec.
- Cohen, E. (2013). Continuing to cooperate: Prerequisites for persistence. *Phi Delta Kappan*, 72, 134-136.
- Cuban, L. (2013). *How teachers taught: Constancy and change in American classrooms 1880-1990*. New York: Teachers College, Columbia University.
- Cuban, L. (2011). *Oversold and undersold: Computers in the classroom*. Cambridge, MA: Harvard University Press.
- Elsenberg, M. B. (2011). Beyond the bells and whistles: Technology skills for a purpose. *MultiMedia Schools*, 8(3), 44-48.
- Felder, R. M. (2013). A longitudinal study of engineering student performance and retention: IV. Instructional methods and student responses to them. *Journal of Engineering Education*, 84(4), 361-367.
- Foresight Research Co., Ltd. (2014). Interim report: Component 1: The productivity analysis of skill delivery institutions. Internal report submitted to World Bank Group in Washington, DC; February 2014.
- Gokhale, A. A. (2012). Collaborative Learning Enhances Critical Thinking. *Journal of Technology Education*, 7(1).
- Gumperz, J., Cook-Gumperz, J., & Szymanski, M. (2013). Collaborative practices in bilingual cooperative learning classrooms.
- Harasim, L. Ed. (2013). *On-Line Education: Perspectives on a new medium*, New York: Praeger/Greenwood.
- Hiltz, S. R., & Benbunan-Fich, R. (2014). Supporting collaborative learning in asynchronous learning networks. Paper presented at the UNESCO/ Open University Symposium on Virtual Learning Environments and the role of the Teacher Milton Keynes, England.
- Ivers, K. S. (2011). Educational technology professional development program. Paper presented at National Educational Computing Conference 2011, Chicago, IL.
- Koul, R., Wiesenmayer, R. L., & Rubba, P. A. (2011). Evaluating RuralNet: Teaching with the Internet. *Journal of Educational Computing Research*, 25(2), 129-140.
- Meng, H., Chun, M. (2014). Examining interpersonal trust as a facilitator and uncertainty as an inhibitor of intra-organisational knowledge sharing. *24(2)*, 119-142.
- Muir-Herzig, R. G. (2014). Technology and its impact in the classroom. *Computers & Education*, 42, p. 111-131.
- O'Dwyer, L. M., Russell, M., Bebell, D., & Tucker-Seeley, K.R. (2015). Examining the relationship between home and school computer use and students' English/language arts test scores. *Journal of Technology, Learning, and Assessment*, 3(3).
- Oppenheimer, T. (2013). *The flickering mind: The false promise of technology in the classroom and how learning can be saved*. New York, NY: Random House.
- Pejuan, A. (2015). An experience of collaborative learning with students beginning engineering. *Recent Research Developments in Learning Technologies*.
- Petropoulos, H. (2011). Are we there yet? How to know when you have enough technology in a school. *Momentum*, 32(3), 12-14.
- Pifarré, M., & Li, L. (2012). Teaching how to learn with a wiki in primary education: What classroom interaction can tell us. *Learning, Culture and Social Interaction*, 1(2), 102-113
- Sutasinee, S. (2014). A Success factor in using ICT for Enhancing Society and Quality in Developing Country, *21(2)*, 126
- Vitartas, P., & Sangkamee, S. (2012). Profiling Thai student's use of the Internet: Implications for web page design. *Managers and Administrators*.

A Proposed Framework For Mobile Internet QoS Customer Satisfaction Using Big Data Analytics Techniques

Ayisat W. Yusuf-Asaju^{1,2}, Zulkhairi Md Dahalin², and Azman Ta'a²

¹University of Ilorin, Nigeria, ayisatwuraola@gmail.com

²Universiti Utara Malaysia, Malaysia {zul; azman@uum.edu.my}

ABSTRACTS

In the past few years, the Nigeria telecommunication industry has experienced tremendous growth and changes to the extent that customers find it much easier to access the internet through their mobile phones. However, the growth in mobile telecoms subscribers comes with challenges of quality of service, which lead to fluctuations in customer satisfaction. Therefore, the present study proposed a customer satisfaction prediction model through the Key performance indicators obtained from the objective measurement of the network traffic using extended and exhaustive study of the literature. The proposed framework would guide mobile network operators on strategies to embark on in order to retain their customers within the network.

Keywords: QoS, QoE, Prediction model, Customer perception, big data analytics and Customer satisfaction.

I. INTRODUCTION

Over the past decades, the telecommunications (telecoms) sector has been the fastest growing industry around the world. For instance, the telecoms industry experienced a tremendous growth of mobile internet users from 3.69 million in 2000 to 3.27 billion in mid 2015 with 45% internet penetration (Internetworldstats, 2015). Also, as at mid 2015, Nigeria has a total of 67.1 million internet users with a total country population of 178.5 million and with an internet penetration rate at 37% (Internetworldstats, 2015). However, the growth of mobile internet users comes with the challenges of network coverage and slow data penetration (Azeez, 2015; Isabona & Ekpenyong, 2015). These challenges result to fluctuations in services (e.g., mobile voice, video, text and data transmission) provided to the customers by the mobile network operators (MNOs) (Rugelj, Volk, Sedlar, Sterle, & Kos, 2014).

In the telecoms industry, among the key drivers of MNOs success are customers experience, expectations, requirements and perception about the

quality of service (QoS) and Quality of Experience (QoE) provided by the MNOs (Agboma & Liotta, 2012). This suggest that, QoS and QoE information are expected to have huge impact on customer satisfaction in terms of the gap between the customer experience and customer expectations (Ibarrola, Saiz, Zabala, & Cristobo, 2014). Hence, the present study considers customer satisfaction as the most significant quality evaluation criteria to determine customer loyalty and retention with a particular network.

To achieve the quality criteria and improve customer satisfaction, the present study employs big data analytics technique as proposed by ITU (2014). The technique has the ability to analyse large data generated in the network traffic of MNOs and one form of the data analytics techniques is predictive analytics, which has the potentials to predict the future based on past occurrences. As a result, the present study propose a mobile internet customer satisfaction prediction model using big data analytics techniques, which is envisage to predict the future customer satisfaction from the previous experiences of the customers while using the service. The remaining structure of the paper is as follows: section 1 discusses the literature on QoS and QoE in mobile telecommunications. Section 2 provides information on QoS and QoE Measurement, while section 3 dwells on Big data analytics and section 4 provides the framework on customer satisfaction prediction model. Finally, section 5 concludes the paper.

II. QoS AND QoE IN MOBILE TELECOMMUNICATIONS

According to International telecommunication Union-Telecommunication (ITU-T) Recommendation E.800 (1994), QoS is describe "as the collective effect of service performances that determine the degree of satisfaction of a user of the service." The description implies that network performance is an antecedent of QoS, which determines the satisfaction of customers with the service provided by the MNOs. Gilski and Stefański (2015) mention that degradation in QoS can be attributed to congestion, delay in network and limited bandwidth as a result of poor capacity

management. In order to monitor such degradation in QoS and ensure allocation of network resources in the case of anomalies detection, the measurement of mobile internet QoS relies on specific parameters such as throughput, information loss ratio, delay and connection set up time (Farid, Shahrestani, & Ruan, 2013; Shaikh, Fiedler, & Collange, 2010; Reichl, Tuffin, & Schatz, 2013). The use of these parameters for QoS measurement enable MNOs to detect variations between the QoS offered and delivered to their respective customers. In addition, Farid et al. (2013) show that the underlying network technologies, network congestion, heterogenous natures of the network traffic and radio channel have effect on QoS condition. Therefore, network traffic management and optimization technologies should be employed in order to enable MNOs improve customer QoS. In fact, customer experience and the technical aspect of QoS is most appropriate for QoS network traffic management. This assumption is in line with the four-layered QoS model defined by ITU-T Recommendation G1000 (2001). This include the QoS requirement, QoS offered, QoS perceived by the customers and QoS achieved by the MNOs. The relationship between the four layers constitutes the overall management of QoS in such a way that the delivering of QoS required by the customers can be planned ahead by the MNOs. This is achievable through monitoring of the network performance. Figure 1 provides a diagrammatical representation of the four-layered QoS model that entails the fundamentals of the practical management of QoS.

Several studies (Ibarrola, Liberal & Ferro, 2010; Koivisto & Urbaczewski, 2004; Stankiewicz, Cholda & Jajszczyk, 2011) had used the four-layered QoS measurement to analyze the relationship between perceived QoS and network performance of MNOs. For instance, Koivisto and Urbaczewski (2004) find no linear relationship between perceived QoS and network performance as indicated by the ITU-T.

Figure 1: Four-Layered QoS

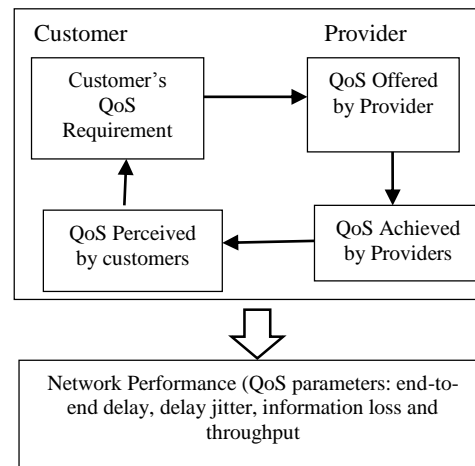

Source: (Farid, et al., 2013; ITU-T Recommendation G1000, 2001).

On the contrary, Ibarrola et al. (2010) and Stankiewicz et al. (2011) document a strong correlation between the network performance and the perceived QoS by the customers. Ibarrola et al (2010) study on QoS management for internet service providers indicate that the recommended process for managing QoS is through the analysis of quality performance measurement, quality of information as perceived by the customers and customer's level of satisfaction. In doing this, it is imperative to define the criteria that are significant to the customers, identify the relationship of such criteria with the network performance, customers perception and expectations. This view is supported by Stankiewicz et al. (2011) whereby they categorise network performance as an intrinsic QoS based on the general QoS model developed by Hardy (2001). The model consists of three layers namely intrinsic QoS, perceived QoS and assessed QoS. The intrinsic QoS describes the network performance, though it is network-centric, but it is very significant to all the aspects of perceived and assessed QoS that is customer-centric (Stankiewicz, et al., 2011). The perceived QoS which reflects the four-layered QoS is influenced by different factors such as the customer experience with the service along with the customers opinions. The layer is the core of the QoS management because it provides the definition of Key performance indicators (KPIs) and Key quality indicators (KQIs), which are useful for defining the QoS required by the customers (Ibarrola, et al., 2014). The assessed QoS comprise of the expectations of customers with the services provided by the MNOs in terms of billing, ordering and correction of errors that occurred while using the provided service (Hardy, 2001). However, ITU-

T introduced a new term called quality of experience (QoE), which can be used to evaluate customer experience with service provided by MNOs. ITU-T P.10/G.100 (2008) describe QoE as “the overall acceptability of an application or service as perceived subjectively by the end-user.” Kilkki (2008) note that the emergence of QoE is because, it is essential to monitor the customer experience with the service and justify the services based on the experience of the customers using the services. In a similar way, Ibarrola et al. (2014) document that QoE has significant influence on customer satisfaction in terms of the gap between customer experience and customer expectation. In addition, QoE, customer satisfaction, customer expectations and attrition rate constitutes assessed QoS, which implies that the variations in the QoS and QoE parameters has negative or positive influence on customer’s satisfaction. Subsequently, Ibarrola et al. (2014) extend the QoS model of Hardy (2001) and Stankiewicz et al. (2011) by adding QoS business to the model which comprises of the customer experience, operational efficiency as well as revenue and margin. Ibarrola et al. (2014) mention the QoS model QoXphere and state that the interactions between each layer of the model would enhance the MNOs to offer a satisfactory services to their customers by monitoring the information provided in each of the layers. The QoXphere model is shown in the Figure 2.

III. RELATIONSHIP BETWEEN QoS AND QoE

According to De Moor et al. (2010) and Fiedler, Hossfeld and Tran-Gia (2010), QoS mainly focus on what is happening within the parameters (such as throughput, packet loss and delay), while QoE place emphasis on why the customers is behaving in a particular way. A generic problem observe in the QoS parameters can translate to QoE problem such as glitches, artifacts and excessive waiting time (Fiedler, et al., 2010). Shaikh et al (2010) argue that response time is very essential when relating QoS with QoE. In the case of mobile internet a bad experience in network behaviour may frustrate the customers and declare such service useless, thereby reducing the service utility.

Figure 2: QoXphere Model

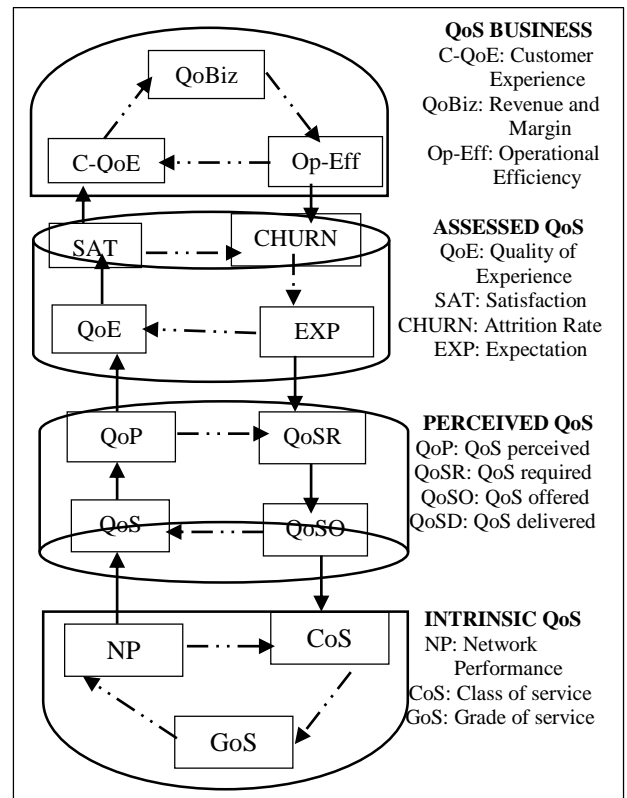

Source: Ibarrola et al. (2014)

Service utility as describe by Ibarrola et al. (2010) constitute the network QoS, availability and customer care. Therefore, waiting and response time of the network as well as response time of customer complains specifically dominate the experience of mobile internet customers while using the service (Egger, Hossfeld, Schatz, & Fiedler, 2012; Singh, et al.,2013). For example, when the customer is browsing the internet through the mobile phone, the QoS parameters deals with the data transmission speed and availability of the network services in respect to prompt response during navigation through the web pages. However, the QoE in this case deals with how long the customer can wait when a delay is encountered and the response time to rectify the delay if the customer place a call to report to the customer care (Diaz-Aviles, et al., 2015). Thus, customer satisfaction can be deduce by mapping the web browsing session time and customer perception of the quality of the web browsing session (Rugelj, et al., 2014). This would enable the possibility of determining how changes in QoS parameters can influence the experience of customers as well as the impact of QoS service utilities and customer experience on customer satisfaction. Based on the

aforementioned arguments, the present study propose a mobile internet QoS and QoE relationship that would enable the proper correlation between the QoS and QoE while measuring QoS and estimating QoE of the mobile internet customers.

Figure 3: Mobile Internet QoS and QoE Relationship

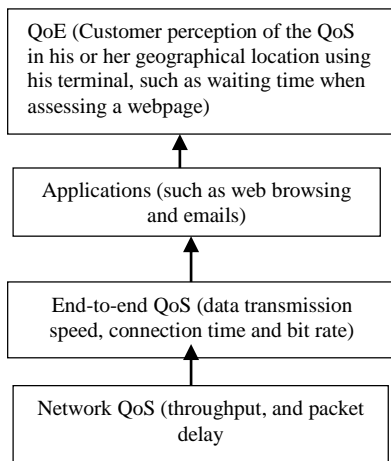

IV. QoS AND QoE MEASUREMENT

Generally, there are two basic types of measurement for QoS perceived and QoE of the customers. This includes subjective and objective measurement. According to ITU-T Recommendation E.802 (2007) and ITU-T Recommendation G.1030 (2015) subjective measurement is based on human judgement mostly carried out through surveys, while objective measurement makes use of technical means usually algorithms to examine the specific network-related problems with QoS. The subjective measurement may falsify results, time consuming and costly (Fiedler et al., 2010). In contrast, the objective measurement has the capability to imitate and predict customer perception based on the network parameters (Singh et al., 2013). Nonetheless, the objective measurement has the ability to extract customer perception from the detailed analysis of customer behaviour generated through the network traffic, thereby identifying the relationship between the technical parameters and actual customer behaviour (Brooks & Hestnes, 2010; Shaikh et al., 2010). In lieu of this, Spiess, T'Joens, Dragnea, Spencer and Philippart (2014) assert that QoE is a big data problem, because the customers data generated through the network traffic is large and customers perception about the service provided by the MNOs depend on the network reliability, coverage, customer care, service provisioning and billing. Similarly, Yin, Jiang, Lin, Luo and Liu (2014) state that QoE is a direct feedback on

network performance, which implies that, if QoE is below expectation, it signifies that there is a problem with the corresponding QoS metrics. On the other hand, if the QoS metric is lower than a threshold, it means that there is a problem in the network performance. Zheng et al. (2016) as well mention that the big data obtained from the objective measurement platform has the potentials to uncover hidden insights on the customers experience that can be used by the MNOs to improve their services. Therefore, customer satisfaction can be modelled by mapping the QoS and QoE metrics using the big data generated in the objective measurement platform or customer historical data of the network traffic of the MNOs. These data can be analysed using big data analytics and can be used by the MNOs to improve the services offered to their customers.

V. SUGGESTED CUSTOMER SATISFACTION PREDICTION FRAMEWORK

The suggested framework is based on Ibarrola et al. (2014), Farid et al. (2013), Ibarrola et al. (2011), Ibarrola et al. (2010) and ITU-T Recommendation G1000 (2001). The parameters of the framework are derived from detailed analysis of prior literature. The three main elements of the framework are objective measurement, QoS parameters and QoE parameters. The QoS parameters consists of end-to-end delay, information loss, availability, and data transmission speed (throughput), while QoE consists of network response time, waiting time and customer complaints response time. The combination of all these elements along with their parameters can be used for customer satisfaction prediction model by mapping the QoS parameters and QoE parameters. This is because the network data which constitute the QoS parameters support the use of big data analytics algorithms. This can further be enhanced by predicting the future occurrences of the network traffic. This would enable the determination of variations in the QoS provided by the MNOs and the QoE observed by the customer while using the mobile internet services. Figure 4 presents the framework.

Figure 4: Customer Satisfaction Prediction Conceptual Framework

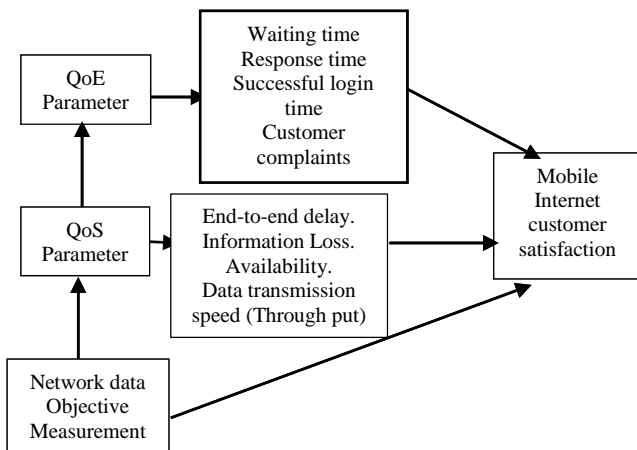

Table 1: Parameters of customers satisfaction prediction framework from the Literature

Authors	Elements	Parameters
Diaz-Aviles et al. (2015); Egger et al. (2012); Fiedler et al. (2010); Shaikh et al. (2010)	QoE	Waiting time, Response time, Successful login time, customer complaints response time.
De Moor et al. (2010); Fiedler et al. (2010); Farid et al. (2013); Gilski and Stefański (2015); Ibarrola, et al. (2010); Ibarrola et al. (2011); Ibarrola et al. (2014); Reichl et al. (2013).	QoS	End-to-end delay, Information loss, Availability, Data transmission speed(Through put)
Brooks and Hestnes (2010); ITU-T Recommendation E.802 (2007); (ITU-T Recommendation G.1030 (2015); Shaikh et al. (2010); (Singh, et al., 2013)	Objective Measurement	Network data Measurement

VI. BIG DATA ANALYTICS

Big data is a collection of large amount of structured and unstructured data that is difficult to analyze using the traditional data management tools (Tiwari, Chaudhary, & Yadav, 2015). The term big data is characterised in terms of volume, variety, velocity, value and veracity of the data (Chandarana & Vijayalakshmi, 2014; ITU, 2014; Sharma, Vaidya, Chaudhary, & Jora, 2015; Tiwari, et al., 2015). Volume describes the mass and quality of the data, velocity entails the speed of data

generation, variety comprises different types of generated data, veracity bring about the accuracy and quality of data sources while value constitutes the potentials of the data to be used to a particular analysis (Chandarana & Vijayalakshmi, 2014; ITU, 2014; Sharma, et al., 2015; Tiwari, et al., 2015). All these characteristics constitute data generated through the network traffic in telecoms industry. The massive amount of data is generated on a day to day basis because of the tremendous increase on the customers mobile internet data subscription. Additionally, the data is of different types such as customer data and application usage behaviour, customer care data, demographics data and traffic data (ITU, 2014). The fast speed of the data generated in the network traffic complies with the big data velocity and is accurate enough because it is generated through the objective measurement (Chandarana & Vijayalakshmi, 2014; ITU, 2014). Thus, appropriate big data analytics tools or techniques can be used to extract important insights useful for an improved decision making which can be used by MNOs to improve their services.

Generally, there are three types of big data analytics; namely; descriptive analytics, predictive analytics and prescriptive analytics (Arora & Malik, 2015). Descriptive analytics employs the use of historical data generated through the network traffic to extract important information from the data. Predictive analytics is concerned with forecasting the future by predicting the future occurrence based on the previous historical data generated through the network traffic. Predictive analytics focuses on decision making through the useful insights extracted from the historical data. This is feasible by having a strong understanding of the suitable analytical techniques which constitutes the statistical analysis, machine learning and data mining algorithms.

According to P. Chen and Zhang (2014), statistical techniques is use to exploits the correlation and casual relationship between diiferent variables. Data mining allows the extraction of valuable information from data, while machine learning makes use of different algorithms to evolve behaviours based on the empirical data. Examples of such algorithms are artificial neural networks, support vector machines, association rules, naïve bayes, k-nearest neighbours, decisions trees,classification, regression, ensembles classifiers, random forest, restricted random forest and many more (Mushtaq, Augustin, & Mellouk, 2012). In addition, P. Chen and Zhang (2014) state that there are several big data framework such as

Hadoop Apache and map/reduce, Dryad, Apache mahout and many more that has the potentials of embedding data mining, statistical and machine learning algorithms to execute large scale data analysis and produce accurate prediction models. Hadoop Apache is the most widely used big data framework because of its reliability, completeness and high scalability (Lim, Chen, & and Chen, 2013; P. Chen & Zhang, 2014).

VII. KEYS STAGES OF CUSTOMER SATISFACTION PREDICTION MODEL FRAMEWORK

The customer historical data constitutes the customer behaviour and experiences while using the internet service. Thus, it is possible to analyse the historical data to extract end-to-end performance metrics that would provide insight on how to improve the services provided by the MNOs and predict the customer satisfaction based on the relationship exhibited between the QoS and QoE. In addition, Ibarrola et al. (2014) QoXsphere model show that network performance (end-to-end performance) is an antecedent of QoS and QoE is an antecedent of customer satisfaction. As a result, the present study focuses on applying descriptive and predictive analytics method using the historical data generated through the network traffic of the Nigeria MNOs to extract useful information regarding the QoS and QoE parameters, that can be used to predict the level of customer satisfaction. The descriptive analytics provides the summary of descriptive statistics for the large datasets, this will allow the observation of the correlation between the QoS and QoE.

Predictive analytics that generate a prediction model is a central problem in machine learning and it produce a model from the training data set in a diverse large data sets (Kim, Kim, & Kim, 2016). The procedure of prediction modelling is to discover and learn accurate models from a large data sets of the customer historical data. The most significant factor that affect performance of such models depends on the accuracy of the generated prediction model. Because the prediction model is a data-driven model that is generated from an infinite sets of samples called training set. Oftentimes, the training set is a limited sample size, so, real model generated from the data is required to describe all the data points within the large data sets (Kim, et al., 2016). Therefore, algorithm evaluation is

required in order to determine the accurate performance of such prediction models.

In the proposed customer satisfaction prediction model, the KPIs extracted are the parameters that are directly obtained from the objective measurement platform of the network traffic. The obtained KPIs is assumed to constitutes the information that can be used to map the network QoS and QoE of the mobile internet to determine the variations in the threshold of the QoS parameters and QoE of the customers. Based on Rugelj et al. (2014)'s study, it can be assumed that past experience of customers can present a key factor like delay that affects the customer perception of quality and satisfaction. Therefore, the impact of past experience on the present customer perception can be determined by measuring the delay observed by the customers while loading a mobile web page, data transmission speed and the service response time (availability). In addition, the prediction of the customer satisfaction can be modelled based on customer's tolerance of the delay, response time of the internet services and the response time of the customer care to rectify potential faults of the network. This is because the KPIs measurement incorporates current customer experience and perception. Hence, variations in customer expectations with the customer experience can be deduced. This would be adopted to model the customers satisfaction prediction based on the objective measurement of the KPIs. As a result, key stages of the mobile internet QoS customer satisfaction prediction model is shown in Figure 5.

VIII. CONCLUSION

This study proposes a framework for mobile internet customer satisfaction prediction model. To achieve the propose framework, a mapping of the QoS and QoE relationship is considered using the KPIs obtained from the objective measurement of the mobile network traffic.

Figure 5: Key Stages Of Proposed Mobile Internet Qos Customer Satisfaction Prediction Model

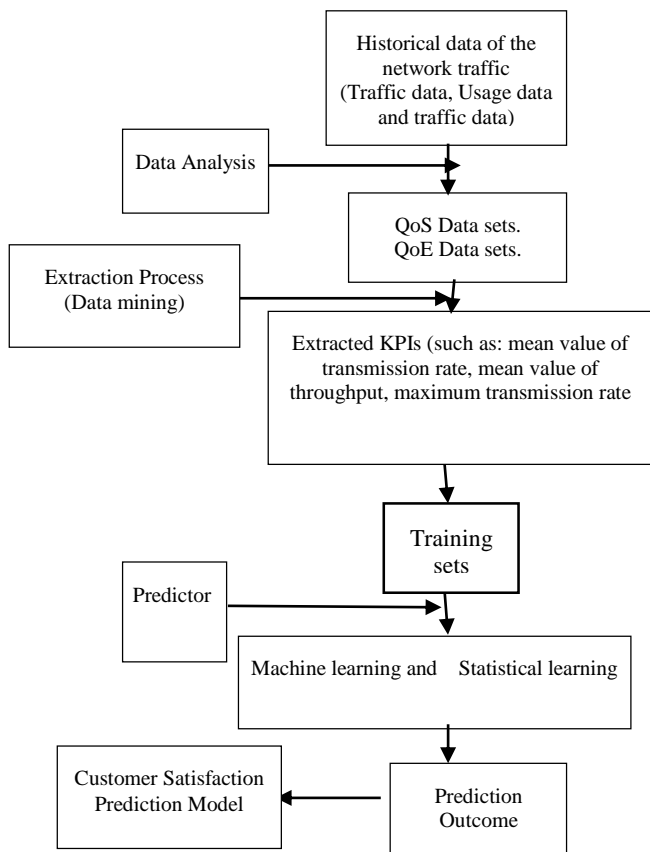

The proposed model is envisaged to be implemented in the future with the aid of big data framework. The proposed framework is expected to solve the challenges encountered in QoS provisioning and fluctuations in customer satisfaction. This is possible by predicting the customer satisfaction based on the the previous experience of the customers which would assist the MNOs to understand the trends of the network traffic and make intelligent decisions that would enable them to improve their network performance. The study is forseen to contribute to the growing literature in the area of using big data analytics for improving the mobile internet QoS that would enhance customer satisfaction.

REFERENCES

Agboma, F., & Liotta, A. (2012). Quality of experience management in mobile content delivery systems. *Telecommun Syst (2012)* 49 doi: 10.1007/s11235-010-9355-6, 85-98.

Arora, D., & Malik, P. (2015). Analytics: Key to go from generating big data to deriving business value. *IEEE First International Conference on Big Data Computing Service and Applications* (pp. 446-452). IEEE Computer Society.

Azeez, K. (2015, October 1). *Telecoms driving economic devt.* Retrieved from newtelegraph: <http://newtelegraphonline.com/telecoms-driving-economic-devt/>

Brooks, P., & Hestnes, B. (2010). User measures of Quality of Experience: Why being objective and quantitative Is important. *IEEE Network*, 8-13.

Chandarana, P., & Vijayalakshmi, M. (2014). Big data analytics frameworks. *International conference on circuits, systems communication and information technology applications (CSACITA)* (pp. 430-434). IEEE.

De Moor, K., Ketyko, I., Joseph, W., Deryckere, T., De Marez, L., Martens, L., & Verleye, G. (2010). Proposed framework for evaluating quality of experience in a mobile testbed- oriented living lab setting. *Mobile Netw Appl* doi: 10.1007/s11036-010-0223-0, 378-391.

Diaz-Aviles, E., Pinelli, F., Lynch, K., Nabi, Z., Gkoufas, Y., Bouillet, E., . . . Salzwedel, J. (2015). Towards real-time customer experience prediction for telecommunication operators. *IEEE International Conference on Big Data (Big Data)* (pp. 1063-1072). IEEE.

egger, S., Hossfeld, T., Schatz, R., & Fiedler, M. (2012). Waiting times in quality of experience for web based services. *QoMEX 2012* (pp. 86-96). IEEE.

Farid, F., Shahrestani, S., & Ruan, C. (2013). Quality of Service concerns in wireless and cellular networks . *Communications of the IBIMA* doi: 10.5171/2013.794626 , 1-15.

Fiedler, M., Hossfeld, T., & Tran-Gia, P. (2010). A generic quantitative relationship between Quality of Experience and Quality of Service. *IEEE Network* 24(2), 36-41.

Gilski, P., & Stefański, J. (2015). Quality Expectations of Mobile Subscribers. *Journal of telecommunications and information technology* 1, 15-19.

Hardy, W. C. (2001). *QoS: Measurement and Evaluation of Telecommunications Quality of Service*. WorldCom, USA: John Wiley & Sons, Ltd .

Ibarrola, E., Liberal, F., & Ferro, A. (2010). Quality of service management for ISPs: A model and implementation methodology based on the ITU-T recommendation E.802 framework. *IEEE Communications magazine*, 146-153.

Ibarrola, E., Saiz, E., Zabala, L., & Cristobo, L. (2014). A new global quality of service model: QoXphere. *IEEE Communications magazine*, 193-199.

Ibarrola, E., Xiao, J., Liberal, F., & Ferro, A. (2011). Internet QoS Regulation in future networks: A user-centric approach. *ITU Kaleidoscope Conference* (pp. 148-155). IEEE Communication magazine.

internetworldstats. (2015, October 29). *Internet Usage Statistics, the internet big picture world internet users and 2015 population stats*. Retrieved from internetworldstats,Miniwatts Marketing Group: <http://www.internetworldstats.com/stats.htm>

Isabona, J., & Ekpenyong, M. (2015). End-User satisfaction assessment approach for efficient networks performance monitoring in wireless communication systems . *African Journal of Computing & ICT* 8(1), 1-16.

ITU. (2014). *Measuring the information society report*. Geneva: International telecommunication union.

ITU-T Recommendation E.800, I. (1994). *Terms and definitions related to quality of service and network performance including dependability*. ITU.

ITU-T Recommendation E.802, I. (2007). *Framework and methodologies for the determination and application of QoS parameters*. ITU.

ITU-T Recommendation G.1030, I. (2015). *Estimating end-to-end performance in IP networks for data applications* . ITU.

ITU-T Recommendation G1000, I. (2001). *Communications quality of service: A framework and definitions*. ITU.

Kilkki, K. (2008). Quality of experience in communication ecosystem. *Journal of universal customer science* 14(5), 615-624.

Kim, J.-S., Kim, E.-S., & Kim, J.-H. (2016). Towards conceptual predictive modeling for big data framework . *International Journal of Software Engineering and Its Applications* 10 (1) , 35-42.

Koivisto, M., & Urbaczewski, A. (2004). The relationship between quality of service perceived and delivered in mobile Internet communications. *Information Systems and e-business management, Springer* doi:10.1007/s10257-004-0045-3, 309-323.

- Lim, E. P., Chen, H., & Chen, G. (2013). Business Intelligence and Analytics: Research directions. *ACM Transactions on Management Information Systems*. 3(4), 1-10.
- Mushtaq, M. S., Augustin, B., & Mellouk, A. (2012). Empirical study based on machine learning approach to assess the QoS/QoE correlation. *17th European Conference on networks and optical communications (NOC)* (pp. 1-7). Vilanova i la Geltru: IEEE doi: 10.1109/NOC.2012.6249939 .
- P. Chen, C., & Zhang, C.-Y. (2014). Data- intensive applications, challenges, techniques and technologies: A survey on big data. *Information science*, <http://dx.doi.org/10.1016/j.ins.2014.01.015>, 1-34.
- Reichl, P., Tuffin, B., & Schatz, R. (2013). Logarithmic laws in service quality perception: where microeconomics meets psychophysics and quality of experience. *Telecommun System* 52(2) doi: 10.1007/s11235-011-9503-7, 587-600.
- Rugelj, M., Volk, M., Sedlar, U., Sterle, J., & Kos, A. (2014). A novel user satisfaction prediction model for future network provisioning. *Telecommunication system*, 56 doi: 10.1007/s11235-013-9853-4 Springer, 417-425.
- Shaikh, J., Fiedler, M., & Collange, D. (2010). Quality of Experience from user and network perspectives. *Ann. Telecommun DOI: 10.1007/s12243-009-0142-x*, Springer, 47-57.
- Sharma, D., Vaidya, P., Chaudhary, K., & Jora, K. (2015). Big data – Competitive intelligence. *2nd International conference on computing for sustainable global development (INDIACom)* (pp. 684-689). India: IEEE.
- Singh, A., Mahmoud, A., Koensgen, A., Li, X., Göerg, C., Kus, M., . . . Grigutsch, J. (2013). Enhancing Quality of Experience (QoE) Assessment Models for Web Traffic. *Institute for Computer Sciences, Social Informatics and Telecommunications Engineering* (pp. 202-215). MONAMI 2013, LNICST 125.
- Spiess, J., T'Joens, Y., Dragnea, R., Spencer, P., & Philippart, L. (2014). Using big data to improve customer experience and business performance. *Bell labs technical journal* 18(4) doi: 10.1002/bltj.21642, 3-17.
- Stankiewicz, R., Cholda, P., & Jajszczyk, A. (2011). QoX: What is it really . *IEEE Communication Magazine*, 148-158.
- Tiwari, A. K., Chaudhary, H., & Yadav, S. (2015). A review on big data and Its security . *IEEE Sponsored 2nd International Conference on Innovations in Information Embedded and Communication Systems* (pp. 1-5). Coimbatore : IEEE doi: 10.1109/ICIIECS.2015.7193110 .
- Yin, H., Jiang, Y., Lin, C., Luo, Y., & Liu, Y. (2014). Big data: Transforming the design philosophy of future internet. *IEEE Network*, 14-19.
- Zheng, K., Yang, Z., Zhang, K., Chatzimisios, P., Yang, K., & Xiang, W. (2016). Big data-driven optimization for mobile networks towards 5G. *IEEE network*, 44-51.

Complaint Management in Public Services: A Case Study at Local District Municipal Authority in Malaysia

Shatina Saad, and Muhamad Halim Nizarwan

Universiti Teknologi MARA (Puncak Alam), Malaysia, shatinas@salam.uitm.edu.my, halimnizarwan@gmail.com

ABSTRACT

This paper presents a conceptualization of the complaint management that focuses on daily customers' activities, which influencing the local municipal district authority organization's public image. The aim of this study is to identify the major concerning areas complaints received by the local municipal district authority organization and to improve the organization's service quality as perceived by customers. Research was conducted based on organization's historical data, which acts as public service to all residents in one of the districts in Selangor, Malaysia. Using descriptive and Pareto Analysis, several results have emerged from the data analysis. The types of complaints were identified and classified into topmost contributors of complaints. Next, major concerning areas for topmost contributors were identified. This study has successfully determined areas which the local municipal district authority organization's should be focusing more to minimize complaints and improving their service. Hence, suggestions were made to aid the local municipal district authority organization to counter the problem arises from the complaints itself.

Keywords: Complaint management, public service, local municipal district authority, service quality.

I INTRODUCTION

Local municipal district authority organization needs to ensure service quality as the highest priority in their local public agency sector. In order to improve and successfully transposed the quality concepts, it is important to know how it can be done with highly effective rate. In this paper, service qualities were measured by the rate of customer complaints received by one of the local districts municipal authority in Selangor, Malaysia. Hence, the service quality improvement in complaint management can be organized, and further suggestions can be proposed for further improvement.

Definitions of service quality revolve around the idea that it is the result of the comparison that customers make between their expectations about a service and their perception of the way the service had been performed (Lewis & Booms, 1983;

Lehtinen & Lehtinen, 1982; Gronroos, 1984; Parasuraman, 1985) as cited by Rodriguez, Burguete, Vaughan and Edwards (2009). Customer complaints are a measure of dissatisfaction about the quality of a product or service (Forbes, 2008). In addition, customer complaints can be used to signal the quality of the service provider towards its potential customers (Brennan & Douglas, 2002). As stated by Hsieh (2012), complaints should be as part of the quality management system. Complaint handling acts as a means of building customer loyalty and increasing the quality of the relationship to the customer (Nel, Atheron, Pitt & Ewing, 2000; Bell, Menguc & Stefani, 2004; Yapp & Skelcher, 2007). Therefore, this research focuses on what the factors that contributed the complaints received by Local district municipal authority in Selangor.

Systemically, analyzing customer complaints can help to find out what and why things went wrong, coming up and idea solutions to fix the problems and prevent them from happening again (Commonwealth of Australia, 2002) as cited by Hsieh (2012). This study too will analyze the types of channel customers report a complaint, whether by phone, form, or online form.

The chosen local district municipal authority in Selangor covers the service to the citizens from its total population of 272,893 people. The public agency consists of 14 departments to service its citizens whom each function differs from each other, and to provide a full extent of servicing towards the local residents. Namely, the various departments are: Management Services Department; Development Planning Department; Valuation and Property Management Department; Youth and Community Department; Engineering Department; Building Control Department; Landscape Department; Complaints, Public Relations and Corporate Unit; Treasury Department; Internal Audit Unit; Town and Environmental Services Department; Legal Unit; Enforcement and Security Division; and Revenue Management Division.

Local district municipal authority in Selangor receives daily complaints from its customers or specifically, local residents in form of direct call, complaint form, and online form. Various complaints were made such as animal problems, garbage dump, sewer and sometimes house problems. Due to high rate of complaints received

every day, the local district municipal authority in Selangor face problems in terms of managing these complaints. Each complaint is classified in each corresponding departments, such as garbage dump in Landscape Department, parking summons in Law Department, road damage in Engineering Department and others in their respective departments. As many complaints were reported, many of them are because of dissatisfaction from the local residents. Therefore, having good management on tackling the complaints is important in order to fulfill customer satisfaction, thus able to improve the service quality of Local district municipal authority in Selangor. This research focuses on what are the factors that contributed the complaints received by the organization.

II LITERATURE REVIEW

This section identifies few factors that included in this research, which are complaint management, customer complaints, and service quality improvement.

A. Complaint Management

This part of section discussed on how using complaints can enhance quality improvement. According to Hsieh (2012) there are three paramount dimensions for using complaints to drive enhancements, which are managerial, operational and technical.

Managerial Dimensions. The essential reasons offered in the literature for quality system achievement or failure are strategic plans, structure, leadership and staff training (Walshe & Freeman, 2002). A quality management framework obliges dynamic leadership in the organization where the managerial dimension relates to quality implementation program. It looks at whether structures and procedures are very much adjusted to improving overall quality, identified with organizational leadership (Davelin & Hand, 1993). Literature is also available on the factors related to the quality management implementation. Subsequently, the managerial dimension primarily contains strategy, structure, leadership, people (training), and culture elements.

Operational dimension. It relates to quality implementation processes involves the way in which quality implementation assets and supports are utilized and the courses of action for monitoring quality implementation work (Walshe & Offen, 2001). The implementation process forms an essential piece of a quality system. As stated by Hsieh (2012), operational dimension relates to the implementation process, organizational changes, and implementation barriers to utilizing complaints to enhance and improve service quality.

Technical dimension. It emphasizes skills, techniques or information systems required to achieve successfully continuous quality improvement (Walshe & Offen, 2001). Compared to managerial and operational issues, skills and techniques for carrying out a quality program are important components in quality program implementation (Develin & Hand, 1993). The technical dimension involves information systems that can facilitate identifying and timely adoption of improved practices.

B. Customer Complaints

Customer complaint emerges because of disappointment, and its force is connected with a level of disappointment (Devereux & Weisbrod, 2006). Customer retention can be achieved by complaint satisfaction. To gain customer retention the first fundamental requirement is complaint satisfaction (Stauss, 2002; Jackson, 2002; Bell & Luddington, 2006). The complainants can be satisfied by brief mindful administration along with polite explanation and compensation (Yavas, Karatepe, Babakus & Avci, 2004). The organizations that stress on satisfaction do not consider their investment useless in developing improvement of complaint handling (Safdar & Ghaffar, 2011). The contribution in preparing, which controls complaint handling system or management certainly is not wasted because satisfaction with complaint handling is connected with trust and commitment (Nel, Athron, Pitt, & Ewing, 2000; Tax, Brown & Chandrashekar, 1998) as cited by Safdar and Ghaffar (2011).

C. Service Quality Improvement

Continuous and consistent effort for service improvement is required in order to survive in an aggressive competition exists in the market. To handle the dynamic competitive environment in the market, immediate response and continuous modification in service action ought to be made (Peng, Hsia & Lu, 2007). It is crucial for public sector to enhance customer service if it wants to reach admirable performance and quality service delivery (Huang, Ho & Lee, 2003). According to Kadir, Abdullah and Agus (2000), in order to attain high performance in providing quality service to the customers, public service sector should give priority to improve customer service. Organizations look for strengths and areas to bring improvement in service to become dominant in the market. Strategies then are formulated by exploring customer needs and expectations (McFarlane, 2001; Folz, 2004; Hunting, Ryan & Robinson, 2014).

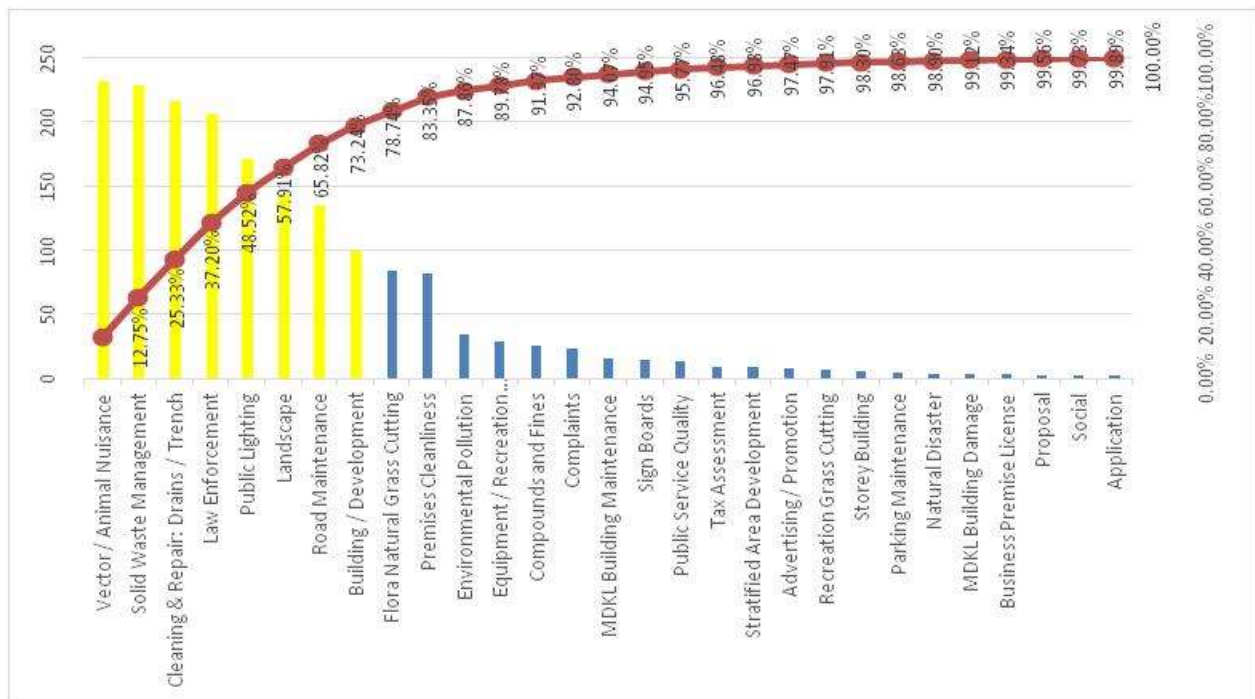

Figure 1. Pareto Analysis For Type of Complaints Received

III METHODOLOGY

This research is descriptive research as it involves an ongoing event in relation to a particular outcome and interest. Salkind (2010) also stressed some advantages of descriptive design. Descriptive design enables a more in-depth examination of a particular situation than other designs. In this research, the researchers focused on the complaints' management in the local district municipal authority in Selangor. Each result of the data obtained were examined for completeness before being entered into a data analysis system. After that, the data collected were analyzed using charts such as Pareto and simple graph charts. Pareto was used as the analysis tool because it highlights the most important among a typically large set of factors. In quality control, it often represents the most common sources of defects, highest occurring type of defect or the most frequent reasons for customer to complaints, and so on (Wilkinson, 2006).

IV RESULTS AND DISCUSSION

For the research work, researchers have collected data starting from 1st January 2014 until 23rd March 2015. As the local district municipal authority in Selangor receives daily complaints from its customers, researchers have observed that there are nine channels for the customers to make a complaint.

Based on result from Table 1, the highest channel used by the residents is e-complaint, meaning they

Table 1. Complaint Channel dated 1st January 2014 – 23rd March 2015

No.	Complaint Channel	Total
1.	E-Complaint	607
2.	Complaint Form	576
3.	Telephone	387
4.	Stars	77
5.	E-Mail	58
6.	Oral	44
7.	Fax/ Mail	38
8.	BPA	19
9.	Others	17
Total		1823

use the organization web homepage to make a complaint. Regarding complaints form, it accounts almost similar with the e-complaint, and these two items contributed the most-used channel in the complaint management.

Next, the researchers compiled and classified the complaints received. Using Pareto analysis, combined data of the period and the types of complaints received been analyzed. From this analysis, identification of the "Vital few" areas where the high number of complaint receive are recognized. The analysis is shown in Figure 1. Here horizontal axis represents the type of complaints, while the vertical axis represents the complaint amount with the cumulative percentage.

Among other complaints, contributions were as follows: Cleaning and Repair: Drains/Trench is 11.87%; Law Enforcement 11.31%; Public Lighting 9.39%; Landscape 7.91%; Road Maintenance 7.41%; Building/Development 5.49% and Flora Natural Grass Cutting 4.61%.

These nine top complaints are the vital few where 78.73% of total complaints received.

Later, further Pareto Analysis is used to perform on those complaints to identify the vital few complaints' types that are responsible for the maximum amount of complaints.

As Public Lighting, Landscape, Natural Flora Grass Cutting, Cleaning and Repair: Drains/Trenches are individually or merely has below four items of each type, there is no need for additional analysis for identifying top complaints in those four positions. So, just Vector/Animals Nuisance, Solid Waste Management, Law Enforcement, Road Maintenance, and Building/Development are needed for additional Pareto Analysis. From this analysis, researchers have identified “vital few” complaint types for each position.

After the Pareto Analysis done it is found that total, eight types of complaints in the identified top complaints areas are responsible for the highest contribution amount of complaints. The complaint types and the corresponding areas with their respective amount are shown in Table 2.

Table 2. Total Amount of Complaints in Major Concerning Areas

Complaint Types	Complaint Position	Amount
Vector / Animal Nuisance	Wild Dog	85
	Pet Dog	64
Solid Waste Management	Uncollected Garbage	101
	Illegal Waste	61
Cleaning Repair: Drains / Trench	Cleaning and Repairs Drains / Trench	216
	Business Without License	86
Law Enforcement	Traffic Obstruction	44
	Heavy Vehicles Nuisance	33
Public Lighting	Damaged Public Lighting	154
Landscape	Cutting Tree	130
Road Maintenance	Damaged Roads	77
	Traffic Congestion	21
Building / Development	Building Without Permission	29
	Property Developer Problem	27
	Building Renovation Work	24
Total Amount		1152

Based from the analysis below are details needed for further improvement in the local municipal authority organization.

Wild Dog is the highest contribution factor in animal nuisance with 36.63% of the total amount. Pet Dog is the second highest contribution in animal nuisance with 27.58% of the total.

Uncollected Garbage contributes the highest amount of complaints in Solid Waste Management data with 44.10% of the total amount. Illegal waste is the second most contributions in the total amount with 26.2%

Business without License has the highest contribution in law enforcement complaints with 41.75% of the total amount. Among other, complaints are traffic obstruction with 21.36% and heavy Vehicles Nuisance with 16.01%. These three complaints types are responsible for 79.13% of total Law Enforcement complaints.

Perforated/Damaged Roads has the highest contribution in Road Maintenance complaints with 57.04% of the total amount. Second highest of the complaint contribution is Traffic Congestion with 15.55% of the total amount. Both complaints' types are responsible for 72.59% of total Road Maintenance complaints.

Building without Permission contributes the highest amount of the complaint in Building/Development with 29.00%. Second is Property Developer Problem with 27.00%. Third with 24% is Building Renovation Work. These three complaint types are responsible for 80.00% of total Building/Development complaints.

From the researchers' observations, literature review and interviews with the local municipal authority staff, some suggestions are provided to efficiently handle complaints and for moreover improvement in service quality. Table 3 discusses further the details for improvement.

Table 3. Total Amount of Complaints in Major Concerning Areas

Major Concerning Areas		Suggestions for Improvement
Complaint Types	Complaint Position	
Vector / Animal Nuisance	Wild Dog	<ul style="list-style-type: none"> Strategize with Veterinary Control Agency. Weekly inspection on areas with high frequency rate. Hires contractors specialize in adopting, fostering or terminating the wild dog.
	Pet Dog	

Solid Waste Management	Illegal Waste	<ul style="list-style-type: none"> Review contractor's assessment of those who are not following terms and contracts.
	Uncollected Garbage	<ul style="list-style-type: none"> Evaluate thoroughly on contractor's performance to choose the best-in-class contractors that suits the task.
Cleaning Repair: Drains / Trench	Cleaning and Repairs Drains / Trench	<ul style="list-style-type: none"> Review contractor's assessment. Evaluate contractor's performance. Create awareness towards citizen for their surrounding residential areas to do self-maintenance on drains surrounding their homes.
		<ul style="list-style-type: none"> Awareness to promote residential hygiene in areas with high frequency rate.
Law Enforcement	Business Without License	<ul style="list-style-type: none"> Creates clear instructions and warning on business without license.
	Traffic Obstruction Heavy Vehicles Nuisance	<ul style="list-style-type: none"> Send officers to regularly patrol on areas frequently having obstruction and vehicles nuisance.
Public Lighting	Damaged Public Lighting	<ul style="list-style-type: none"> Create awareness towards citizens on public lighting. Awareness on vandalism in citizens' residential areas. Terms with contractors to do monthly maintenance on public lighting, especially areas with high population.
		<ul style="list-style-type: none"> monthly inspection on residential areas density with trees and most top areas related with tree cutting complaints.
Road Maintenance	Cutting Tree	<ul style="list-style-type: none"> Remove dead trees
		<ul style="list-style-type: none"> Review contractors' assessment. Evaluate thoroughly on contractor's performance to choose the best-in-class contractors that suits the task. Investigate the frequent road damaged, so that investigation will find the right causes that

Traffic Congestion		<ul style="list-style-type: none"> contribute to road damage such as condition of land or heavy vehicles. Team-up with local police department to control the traffic during peak hours. By using company's complaint data on traffic congestion, data related on this problem should be shared with police team to lower the rate of congestion.
Building / Development	Building Without Permission Property Developer Problem	<ul style="list-style-type: none"> Creates easy and clear instructions regarding building permission and renovation work. Creates new or efficient process flow regarding building permission and renovation work.
	Building Renovation Work	<ul style="list-style-type: none"> Evaluate contractors related on residential projects, thorough evaluation to them to avoid future problems regarding property development projects.

By taking effective measure on tackling those complaints, it is possible to achieve high efficiency in improving service quality provided by the local district municipal authority in Selangor. So, the more successfully those suggestions can be applied, the more complaints can be minimized.

V CONCLUSION

It has been established that complaints in the local district municipal authority arises from dissatisfaction with services, given the complexity of district services and the diversity of departments involved; it is not surprising. Complaint management should be an important component in the quality system because it can identify areas that need improving, providing an opportunity to give service and satisfactions towards dissatisfied customers, strengthens customer support and gives them the opportunity to have their complaints considered in a clearly defined process.

ACKNOWLEDGMENT

The authors would like to acknowledge the people involved in this research from the organization and appreciate the several reviewers for their precious suggestions and input, which have improved the paper quality from former version.

REFERENCES

- Bell, S. J., & Luddington, J. A. (2006). Coping with customer complaints. *Journal of Service Research*, 8(3), 221-233.
- Bell, S. J., Menguc, B., & Stefani, S. L. (2004). When customer disappoint: A model of relational internal marketing and customer complaints. *Journal of Academy of Marketing Science*, 32(2), 112-216.
- Brennan, C., & Douglas, A. (2002). Complaints Procedure in Local Government. *International Journal of Public Sector Management*, 15(3), 219-236.
- Develin, N., & Hand, M. (1993). *Total Quality Management: Breaking down the Barriers*. London: Chartered Accountants Hall.
- Devereux, P. J., & Weisbrod, B. A. (2006). Does "satisfaction" with local public services affect complaints and geographic mobility? *Public Finance Review*, 34(2), 123-147.
- Folz, D. H. (2004). Service Quality and Benchmarking the Performance of Municipal Services. *Public Administration Review*, 64(2), 209-220.
- Forbes, S. J. (2008). The Effect of Service Quality and Expectations on Customer Complaints. *Journal of Industrial Economics*, 1.
- Glezerman, M. (1999). A model of efficient and continuous quality program improvement in a clinical setting. *International Journal for Quality in Health Care*, 11(3), 227-32.
- Hsieh, S. Y. (2012). Using complaints to enhance quality improvement: developing an analytical tool. *International Journal of Health Care Quality Assurance*, 25(5), 453-461.
- Huang, J. H., Ho, S. H., & Lee, B. C. (2003). Who are the adorable customers-men or women? Service quality improvement via customers' positive responses. *Total Quality and Business Excellence*, 14(7), 789-800.
- Hunting, S.A., Ryan, R. & Robinson, T.P. (2014). *Service delivery review: a how to manual for local government*, 2nd edn, Australian Centre of Excellence for Local Government, University of Technology, Sydney
- Jackson, R. (2002). The customer is Always Right. *The Reference Librarian*, 35(75), 205-216.
- Kadir, S. L., Abdullah, M., & Agus, M. (2002). On Service Improvement Capacity Index: A case study of the public service sector in Malaysia. *Journal of Total Quality Management*, 11(4), 837-843.
- McFarlane, D. G. (2001). Managing Improvement in the Public Sector. *Total Quality Management and Business Excellence*, 12(7), 1047-1053.
- Nel, D., Atheron, T., Pitt, L., & Ewing, M., (2000). Customer Evaluations of Service Complaint Experiences in the Public Sector. *Journal of Non Profit & Public Sector Marketing*, 7(3), 3-30.
- Perng, Y. H., Hsia, Y., & Lu, H. (2007). A service quality improvement dynamic decision support system for refurbishment contractors. *Journal of Total Quality Management*, 18(7), 731-749.
- Rodríguez, G. P., Burguete, V. J., Vaughan, R., & Edwards, J. (2009). Quality Dimensions in the Public Sector: Municipal Services and Citizen's Perception. *International Review on Public and Nonprofit Marketing*, 6(1), 75-90.
- Safdar, M., & Ghaffar, Q. d. (2011). Customer Complaints and Service Improvement. *Journal of Business Strategies*, 5(2).
- Neil J. Salkind (Ed.). (2010). *Encyclopedia of Research Design*. Thousand Oaks, CA: SAGE Publications, Inc.
- Stauss, B. (2002). The dimensions of complaint satisfaction: Process and outcome complaint versus cold fact and warm act complaint satisfaction. *Managing Service Quality*, 12(3), 173-183.
- Walshe, K., & Freeman, T. (2002). Effectiveness of Quality Improvement: learning from evaluations. *Quality & Safety in Health Care*, 11(1), 85-87.
- Walshe, K., & Offen, N. (2001). A very public failure: lessons for quality improvement in healthcare organisations from the Bristol Royal Infirmary. *Quality in Health Care*, 10(4), 250-256.
- Wilkinson, L. (2006). Revising the Pareto Chart. *The American Statistician*, (60), 332-334.
- Yapp, C., & Skelcher, C. (2007). Improvements Boards: Building capability for public service improvement through peer support. *Public Money and Management*, 27(4), 285-292.
- Yavas, U., Karatepe, O. M., Babakus, E., & Avci, T. (2004). Customer complaints an organizational responses: A study hotel guests in Nothern Cyprus. *Journal of Hospitality Marketing and Management*, 11(2), 31-46.

The Relationship and Influence of Leadership Style Towards Knowledge Management Activities

Ahmad Sufi Alawi Idris¹, Adnan Jamaludin², Abd. Latif Abdul Rahman¹ and Ayuffeairah Mislan³

¹Universiti Teknologi MARA (Kedah), Malaysia, {sufidris;ablative}@kedah.uitm.edu.my

²Universiti Teknologi MARA (Shah Alam), Malaysia, adnanj@salam.uitm.edu.my

³Universiti Teknologi MARA (Kelantan), Malaysia, ayuyuzm611j@gmail.com.

ABSTRACT

The study emphasized that the concept of leadership is not confined just to a certain group of individual that is appointed by an organization to handle administrative matters. Researchers from the epistemology of leadership believed that the term leaders refer to everyone from the CEO and board of directors down to unofficial opinion leaders who work on the factory floor. Therefore, the purpose of this paper is to propose a framework to identify the individual leadership style of employees regardless of their position within the organization, which is believed to be directly influencing the richness of their daily knowledge management activities in the organization.

Keywords: Leadership style, Knowledge Management, Knowledge Management activities.

VI INTRODUCTION

Over the past few decades the concept of Knowledge Management (KM) has evolved tremendously to transform the ever changing characteristics of organization's inner working especially in the present age of knowledge economy. Crawford (2005) described this evolution of KM as a true paradigm shift. In short, KM can be seen as a discipline consisting of diverse practices pertaining to the management of knowledge in organization's workforce. Therefore, in the knowledge economy, the interest towards the field of KM has intensify among practitioners and academics (Hislop, 2009), this phenomenon was in regard to the shifting focus towards the knowledge as commodities, and the acknowledgement that knowledge is considered as one of the primary asset for organizations (Sewell, 2005).

Furthermore, knowledge has long been regarded and acknowledged as a valuable organizational commodity in today's economy. Bhatt (2001) posits the belief that academicians and practitioners alike agreed that by leveraging upon knowledge, it could ensure that organizations can sustain its long term competitive advantage. According to Davenport and

Prusak (1998) in the knowledge economy the only sustainable advantage an organization possesses are derived from what it collectively knows, how efficiently it uses what it knows, and how quickly it acquires and uses new knowledge. The fundamental behind KM arose from the awareness towards the importance of managing personal knowledge and diffusing it as a collective knowledge for success and well being of organizations. Stonehouse and Pemberton (1992) suggested that the role of KM is to ensure that individual learning becomes organizational learning. Similarly, Nickols (2000) posits the belief that the basic aim of KM is to leverage individual knowledge to the organization's advantage. KM, therefore, is essential for generating and sustaining competitive advantage as it supports knowledge management activities, specifically leveraging on individual knowledge and effectively transforming into organizational knowledge.

In brief, KM can be defined as the ability of an organization to manage, store, value, and distribute knowledge (Liebowitz & Wilcox, 1997). But however, as simple as it may sound, knowledge itself possesses unique paradoxical characteristics that make it unique to its beholders; it is personal in nature and embedded within individual. Therefore, knowledge is not something that is not easily given away nor can be taken away considering the advantages the owner gains from it. These knowledge bearing individuals and their knowledge activities are believed to be motivated by their individual leadership style. Nevertheless, organizations may provide all the necessary infrastructures and technological advancements to support KM activities, however in the end it all boils down to each and every one individual employees to participate, engage and perform KM activities.

Additionally, Von Krogh et al. (1997), posits the belief that when an individual creates new knowledge, that particular person is progressing in making sense out of a new situation by holding justified beliefs and committing to them. Similarly Sanchez (2005) mentioned that the ultimate source of organizational knowledge is the knowledge that the individuals in the organization develop through their own personal sense-making processes. This

shows that knowledge is created and embedded in individuals, perhaps a specific type of knowledge relating to their work, but nonetheless that knowledge is an accumulation of one's action towards attaining the knowledge whether directly or indirectly; intentionally or unintentionally. And this knowledge bearing individuals are essential building blocks for the productivity and success of an organization. Therefore, the success of KM practices depends upon knowledge management activities of individuals within organizations and the ability to convert it into collective knowledge.

VII PROBLEM STATEMENTS

The fundamental elements of KM and its benefits to the organization is the knowledge management activities, which means that people in the organization have to play their fundamental role in which they need to perform and carry out the KM activities. KM activities are performed by each and everyone in the organization such as identifying and creating knowledge, collecting and capturing knowledge, storing, sharing and applying knowledge that are related to the domain of the organization. These knowledge bearing individuals and their knowledge activities depends upon their unique individual characteristics, particularly their leadership style which naturally embedded in them. In this context, some individuals with their naturally embedded leadership style may contribute positively towards the knowledge management activities in the organizations. This is to mean that, there could be a significant relationship between individual leadership style and knowledge management activities in which if this assumption is true, the knowledge management activities of an individual could be predicted based on one's leadership styles.

Lacking or no studies on this issue has left a gap in the KM domain (Analoui, 2012 & Hislop, 2009). Although there are some studies examining the characteristics of leadership and KM (Politis, 2001; Gloet, 2006; Lakshman, 2007; Singh, 2008; Analoui, 2012; Donate & De Pablo, 2015), but however the focus is on the roles of KM leader who were regarded as persons with administrative authority such as Chief Knowledge Officer (CKO), KM Managers, Chief Executive Officer (CEO), Chief Information Officer (CIO) etc. and not on the leadership style of individual employees of the organization. Whereby, DeTienne et al. (2004) believed that the term leader refers to everyone from the CEO and board of directors down to unofficial opinion leaders who work on the factory floor. Therefore, in this present study, individual leadership styles are taken into account to close up the gap left by the previous studies to explain personal knowledge management activities.

VIII LEADERSHIP STYLE

There is no agreed upon definition for the concept of leadership. According to Stogdill (1974, p. 259), "there are almost as many definitions of leadership as there are persons who have attempted to define the concept." Leadership is a discipline that had received numerous interpretations, and to define leadership itself is not an easy task (Kent, 2005). Some definitions that can be generated from the literature pertaining to leadership are: (1) Leadership is a process of social influence, which maximizes the efforts of others, towards the achievement of a goal (Kruse, 2013); (2) A process whereby an individual influences a group of individuals to achieve a common goal (Northouse, 2007); and the list goes on. It could be generated that leadership is a process by which an individual influences others to accomplish an objective and directs the organization in a way that makes it more cohesive and coherent. Interestingly, it was articulated that leadership within the process of knowledge management can be defined as a process, where other members of the group are supported individually in learning processes needed in order to achieve the goals of the group or the objectives of the organization (Stogdill, 1974; Dfouni, 2002; Vitaala, 2004). Nonetheless, the highlighted definitions were purposely selected to show that leadership usually involved a person influences others through social influence, not power, to get something accomplished and leadership requires others, who are not necessarily direct-reports, to get something accomplished.

As reported earlier, Hislop (2009) articulated that there are still relatively little work has been done to determine which styles of leadership are most effective for influencing knowledge management activities. To show how enormous the discipline is, Fleishman et al. (1991) has analyzed that in the past 50 years that have been as many as 65 different classification systems developed to define the dimensions of leadership. Leadership has been studied by many scholars in many different fields. In general, scholars have different perceptions and preferences. Some leadership studies emphasize the importance of the traits of leaders whereas others stress the importance of behavioral factors and characteristics of the leaders (Yukl, 1989). Hence this study will void the broad spectrum of leadership discipline and shift the focus on the leadership styles as mentioned by Hislop (2009).

The concept of leadership style is that we all have preferences for the way we influence others e.g., relate to others, interact, and learn. Most leadership styles approaches suggest that leadership styles are preferences, and that they can be changed, since they are not fixed. A leadership style is a leader's

style of providing direction, implementing plans, and motivating people.

Within the context of the leadership styles, Hersey and Blanchard (1982) proposed four style of leadership. The styles are:

1. Directive: This leadership style refers to person who displayed leadership style that is considered to be high on regulating but low on nurturance behavior.
2. Supportive: This leadership style is characterized by leadership who is perceived to be high on both regulation and nurturance behavior.
3. Consulting: This leadership style is characterized by leadership behavior which is low on regulation but high on nurturance.
4. Delegating: This leadership style is characterized by leadership behavior that is low on both regulation and nurturance

Goleman (2000) uncovered six (6) different leadership styles which consist of:

1. Commanding
2. Visionary
3. Affiliative
4. Democratic
5. Pacesetter
6. Coaching

House (1971) identifies four (4) leadership styles that consist of:

1. Directive
2. Supportive
3. Participative
4. Achievement – Oriented

However, according to Analoui (2012), of the studies that have been produced on leadership and KM, none have examined the relationship between Avolio and Bass' (2004) transformational, transactional and passive-avoidant leadership styles and a full range of organizational knowledge management activity. Therefore, in the effort to fulfill this gap, which is empirically true in the Malaysian context, the study will attempt to execute the suggested concept above.

Avolio and Bass' (2004) style of leadership had been widely discussed in literature across diverse fields, and their Multifactor Leadership Questionnaire (MLQ) on determining leadership styles has also been widely utilized by researchers and organization

in identifying and measuring leadership style. Avolio and Bass (2004) state that the transformational leadership style is comprised of five dimensions:

1. Idealized influences (attributes) – whereby leaders are admired, trusted, have high standards of ethical and moral conduct, are held in high regard and engender loyalty from followers.
2. Idealized influence (behaviors) – as above but displaying behaviors including the leader talking about his/her most important values and beliefs, specifying the importance of having a strong sense of purpose and considering the moral and ethical consequences of decisions.
3. Inspire motivation – whereby leaders behave in ways that motivate those around them, providing meaning and challenges for their followers.
4. Intellectual stimulation – whereby leaders stimulate their followers' effort to be innovative and creative by questioning assumptions, reframing problems and approaching old situations in new ways.
5. Individualized consideration – whereby leaders pay attention to their followers' needs and concerns as individuals and develop their strengths through behaviors such as coaching and consulting.

The transactional leadership style is comprised of two dimensions:

1. Contingent reward – whereby leaders clarify expectations and offer recognition when goals are achieved. Satisfaction when others meet expectations
2. Management-by-exception (active) – whereby leaders specify the standards for compliance, as well as what constitutes ineffective performance, monitor performance and take corrective action, but only when performance is not as would be expected.

Finally, Avolio and Bass (2004) described passive avoidant leadership as being comprised of two dimensions:

1. Management-by-exception (passive) – which is similar to the active form of the behavior but differs in that leaders only take corrective action when a problem becomes serious.
2. Laissez-faire – it considered to be a form of non-leadership, under this condition individuals avoid leadership, responsibility and

activity, failing to be involved when important issues arise.

IX KNOWLEDGE MANAGEMENT ACTIVITIES

KM was initially defined as the process of applying a systematic approach to the capture, structuring, management, and dissemination of knowledge throughout an organization to work faster, reuse best practices, and reduce costly rework from project to project (Nonaka and Takeuchi, 1995). According to Newman (1991) KM is a discipline that seeks to improve the performance of individuals and organizations by maintaining and leveraging the present and future value of knowledge assets.

Eventually over the years, KM has been discussed and debated extensively and the field itself developed a solid requirement for a more systematic and deliberate approach to cultivate and distribute an organization's knowledge base; one populated with valid and valuable lessons learned and best practices. But however, regardless of the wealth of documented materials such as monographs, reports, periodicals and thesis, neither researchers nor practitioners have an agreed definition of KM. Up until today, there had been numerous published definitions of KM, each with distinctively unique perspectives but yet related to each others, which indicates that KM is a multidisciplinary field of study that covers diverse areas. Nonetheless, regardless of the term employed to describe it, KM is increasingly seen, not merely as the latest management fashion, but as signaling the development of a more organic and holistic way of understanding and exploiting the role of knowledge in the processes of managing and doing work, and an authentic guide for individuals and organizations in coping with the increasingly complex and shifting environment of the modern economy (Mentzas et al., 2003).

The process of KM is based on the ability of all members of the organization to add value to the basic business processed through creation, communication, codification and coordination of both explicit and tacit knowledge stores (Nonaka and Takeuchi, 1995). This shows that the success of KM is much depended upon the contribution of personal knowledge that resides within individuals, and this distinct knowledge is the building blocks of a successful KM practices in an organization. Similarly, Stonehouse and Pemberton (1992) suggested that the role of KM is to ensure that individual learning becomes organizational learning. Bollinger and Smith (2001) concluded that knowledge management activities is not so much about control as it is about sharing, collaboration, and making the best possible use of a knowledge

resource which emphasize there are needs to understand the KM activities of individuals beforehand. Therefore, various scholars had been discussing and highlighting the activities associated with knowledge management:

Seng, Zannes, and Pace (2002) had proposed five activities of managing knowledge:

1. Capturing knowledge
2. Storing knowledge
3. Processing knowledge
4. Sharing knowledge
5. Using knowledge

Barth (2003) had outlined several distinctive personal knowledge management activities, these includes;

1. Accessing
2. Evaluating
3. Organizing
4. Analyzing
5. Conveying
6. Collaborating
7. Securing

Arthur and Anderson (2001) stresses that KM activities are divided into 7 steps, they are:

1. Knowledge Identification
2. Knowledge Collection
3. Knowledge Adaption
4. Knowledge Organization
5. Knowledge Application
6. Knowledge Sharing
7. Knowledge Creation

Wiig (1993) had proposed 3 categorization of KM activities, which consists of:

1. Knowledge creation
2. Knowledge manifestation
3. Knowledge use and Transfer

Meanwhile Ling (2011) conducted a review on the variations and similarities from the various definitions of KM activities since 1990s with the aim of finding out which is the most suitable one to adopt. Based on the scope of the 55 articles, Ling (2011) identified that there are four frequently highlighted KM activities, these are:

1. Creating knowledge

2. Storing knowledge
3. Sharing knowledge
4. Utilizing knowledge

Maier and Moseley (2003) had proposed their own categorization of KM activities, which been widely used in researches and organizations to assess KM activities. They have categorized KM activities as follows:

1. Knowledge identification and creation
2. Knowledge collection and capture
3. Knowledge storage and organization
4. Knowledge sharing and dissemination
5. Knowledge application and use

Therefore, the study views the categorization of KM activities as proposed by Maier and Moseley (2003) as mostly relevant to examine KM activities. In addition, other KM activities framework that had been discussed will be integrated into the framework. Firstly, knowledge identification and creation examines the effectiveness in transforming data and information into knowledge based assets (Jha, Mahajan and Joshi, 2013); Knowledge collection and capture looks into how well knowledge is captured once it has been identified (Jha, Mahajan and Joshi, 2013); Knowledge storage and organization discusses about how once knowledge is captured, it has to be stored an organized for easy retrieval by the knowledge holder and others (Jha, Mahajan and Joshi, 2013); Knowledge sharing and dissemination scrutinizes the sharing and dissemination of knowledge using both non electronic and electronic methods of sharing such as the use of meetings, memos and email (Singh, 2008); and lastly, knowledge application and use looks into the application and use of knowledge acquired using both technological and non technological processes (Singh, 2008). Therefore, this categorization will serve as a guideline to the personal knowledge management activities of the employees within an organization.

X CONCEPTUAL FRAMEWORK

Based on the foregoing discussion, figure 1 presents the conceptual framework of the study which seeks out to examine leadership styles and the impact towards personal knowledge management activity. For the purpose of the study, the framework will be adopted from leadership style (Avolio and Bass, 2004) and Knowledge Management Activities by Maier and Moseley (2003).

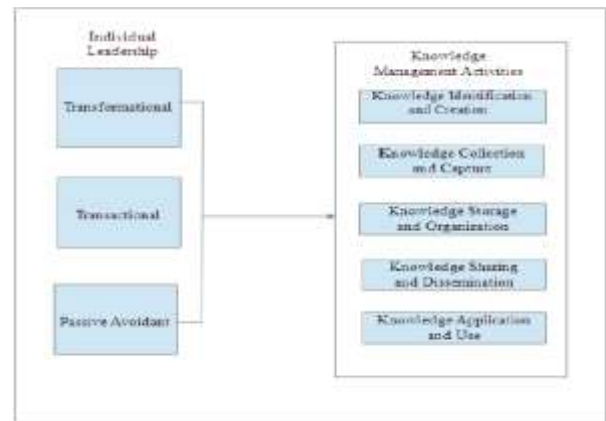

Figure 1. Conceptual Framework

The conceptual framework consists of Independent Variable namely Individual Leadership Style consisting of Transformational, Transactional, and Passive Avoidant. On the other hand, the Dependent Variables namely Knowledge Management Activities consist of Knowledge Identification and Creation, Knowledge Creation and Capture, Knowledge Storage and Organization, Knowledge Sharing and Organization; lastly Knowledge Application and Use.

XI CONCLUSION

Knowledge are embedded in people, they will over time develop it and when required they will take actions based upon the knowledge that they possesses. Lakshman (2007) emphasizes that knowledge is basically nothing without people. Data can be transmitted, information can be shared, but knowledge is an attribute of people, or communities or societies. While knowledge is increasingly being viewed as a commodity or intellectual asset, there are some paradoxical characteristics of knowledge that are radically different from other valuable commodities. Therefore, this paper contributes to the body of knowledge by highlighting the leadership style of individual employees as the influential factors towards knowledge management activities. Furthermore, it was articulated that there are still relatively little work has been done to determine which styles of leadership are most effective for influencing knowledge management activities.

REFERENCES

- Analoui, B. D., Doloriert, C. H. & Sambrook, S. (2012). Leadership and knowledge management in UK ICT organizations. *Journal of Management Development*. 32, 4 – 17.
- Avolio, B.J. & Bass, B.M. (2004), *Multifactor Leadership Questionnaire: Manual and Sampler Set*. (3rd ed.). Mind Garden, Redwood City, CA.
- Bhatt, G. D. (2001). Knowledge management in organizations: examining the interaction between technologies, techniques, and people. *Journal of Knowledge Management*.5, 68 – 75.

- Cavaleri, S., Seivert, S., & Lee, L.W. (2005). *Knowledge leadership: The art and science of the knowledge-based organization*. United States of America: Elsevier Butterworth-Heinemann.
- Crawford, C. B. (2005). Exploring the relationship between knowledge management and transformational leadership. *Knowledge Management and Leadership*. 2, 14-22.
- Cummings, J. N. (2004). Work groups, structural diversity, and knowledge sharing in a global organization. *Management Science*. 50, 352-64.
- Davenport, T. H. & Völpel, S. C. (2001). The rise of knowledge towards attention management. *Journal of Knowledge Management*. 5 (2), 212 – 222.
- De Tienne, B., et al. (2004). Toward a model of effective knowledge management and directions for future research: culture, leadership, and CKOs. *Journal of Leadership and Organizational Studies*. 10, (4), 26-4.
- De Long, D. W. & Fahey, L. (2000). Diagnosing Cultural barriers to knowledge management. *Academy of management Executive*. 14(4), 113.
- Drucker, P. F. (1993). *Managing in turbulent times*. New York, Harper & Row.
- Earl, M. J. & Scott, I. A. (1999). What is a Chief Knowledge Officer? *Sloan Management Review*. 40(2), 29-38.
- Gloet, M. (2006). Knowledge management and the links to HRM. *Management Research News*. 29(7), 402 – 413.
- Griffiths, P. & Remenyi D. (2008). Aligning knowledge management with competitive strategy: A framework. *The Electronic Journal of Knowledge Management*. 6(2), 25- 134.
- Hislop, D. (2009). *Knowledge Management in Organizations*. (2nd ed.). Oxford University Press, New York, NY.
- Kok, J. A. (2003). Role of leadership in the management of corporate knowledge. *South African Journal of Information Management*. 5 (3).
- Lakshman, C. (2007). Organizational knowledge leadership: a grounded theory approach. *Leadership & Organization Development Journal*. 28, 51 -75
- Liebowitz, J. (1999). Key ingredients to the success of an organization,,s knowledge management strategy. *Knowledge and Process Management*. 6(1), 37-40.
- Ling, L. S. (2011). Defining Knowledge Management (KM) Activities from Information Communication Technologies (ICTs) Perspective. *Journal of Organizational Knowledge Management*.
- Salter, C. R., Green, M., Ree, M., Carmody-Bubb, M., & Duncan, P. (2009). A Study of Followers Personality, Implicit Leadership Perceptions, and Leadership Ratings. *Journal of Leadership Studies*. 48-60.
- Seng, C. V., Zannes, E., & Pace, R. W. (2002). The contributions of knowledge management to workplace learning. *Journal of Workplace Learning*. 14(4), 138-147.
- Simson, J. N. & Ahmad, R. (2014). Effects of knowledge leadership behavior in KM applications. *International Journal of Advances in Computer Science and its Applications*. 4 (1).
- Singh, S. K. (2008). Role of leadership in knowledge management: a study. *Journal of Knowledge Management*. 12 (4), 3 – 15.
- Sveiby, K. E. (2001). A knowledge-based theory of the firm to guide in strategy formulation. *Journal of Intellectual Capital*. 1(4), 344 – 359.
- Syed Omar Sharifuddin Syed-Ikhsan & Rowland, F. (2004). Knowledge management in a public organization: a study on the relationship between organizational elements and the performance of knowledge transfer. *Journal of Knowledge Management*. 8 (2), 95 – 111.
- Viitala, R. (2004). Towards knowledge leadership. *Leadership & Organization Development Journal*. 25 (6), 528 – 544.
- Yang, Li-R., Huang Chung-F. & Hsu, Ting-J. (2013). Knowledge leadership to improve project and organizational performance. *International Journal of Project Management*. 32, 40-53.
- Wiig, K. M., (1993). *Roles of Knowledge-Based Systems in Support of Knowledge Management, Knowledge Management and Its Integrative Elements*. CRC Press, New York. 69-87.
- Nissen, M.E. (2006). *Harnessing knowledge dynamics: Principled organizational knowing and learning*. Book Review Published online 29 January 2008; Springer Science and Business Media, LLC.
- Nonaka, I. (1991). *The Knowledge-Creating Company*. Harvard Business Review from the July-August 2007 issue.
- Nonaka, I. and Takeuchi, H. (1995). *The Knowledge Creating Company*. Harvard Business Review from the May-June 2005 issue.
- Politis, J. D. (2001). The relationship of various leadership styles to knowledge management. *Leadership & Organization Development Journal*. 22(8), 354 – 364.
- Maier, D. J., and Moseley, J. L (2003). *The Knowledge Management Assessment Tool*. Pfeiffer. (Available online at <http://www.pfeiffer.com/WileyCDA/>).
- Macneil, C. (2001). The supervisor as a facilitator of informal learning in work teams. *Journal of Workplace Learning*. 13 (6), 246-253

Identifying Game Design Factor for The Development of Educational Digital Games

Sumet Pongphankae¹, and Jittrapol Intarasirisawat²

¹Rangsit University, Thailand, sumet@rsu.ac.th

²Prince of Songkla University, Thailand, jittrapol.psu@gmail.com

ABSTRACT

Designing and developing educational digital games are complicated processes. In both cases, multidisciplinary teams are required. Moreover, designing a diverse range of educational digital games from start to end can be different in each case. This paper introduces a concise model for designing digital games with an aim to assist and support both educators and game designers. In addition, this model will bridge the gap between educators and game designers, so as to achieve the common goal of developing effective educational digital games. This study intends to investigate and conduct a comprehensive review of the main features and factors for developing educational digital games suitable for different educational contents and platforms. Furthermore, the proposed model is believed to bring benefits to both educators and game designers who are involved in the game design process for digital game-based learning.

Keywords: Educational Game, Game-based learning, Game Design Process, Expert System, Game Factor.

I INTRODUCTION

There were many studies on the impact of games and it has been reported that video games are good for learning (Halverson, Shaffer, Squire, & Steinkuehler, 2006; Prensky, 2004; Rapeepisarn, 2012; Squire, 2008). For the younger generation, it appears that face-to-face learning seems to be less attractive than studying with immersive digital game environments (Carina, 2012; Chang, Hwang, Chen, & Mueller, 2011; Foreman, 2003; Whitton & Moseley, 2012). To facilitate learners' engagement in interactive learning environments from the prospective of learning, digital games can increase learners' motivation and interest (Aldrich, 2003; Rapeepisarn, Pongphankae, Wong, & Fung, 2008; Squire, 2008). These findings have motivated many researchers to investigate how to make educational

digital games and how to use them to improve learners' experience.

An effective educational game has been known to offer many advantages and improve the learners' problem solving skills (Gros, 2007; Squire, 2008). Moreover, computer games can serve as virtual worlds, which cultivate peer groups with social competence to share knowledge, skills, and resources (Gee, 2004; Halverson, Shaffer, Squire, & Steinkuehler, 2006; Prensky, 2004; Rapeepisarn, 2012; Squire, 2008). However, it does not guarantee that the use of computer games will bring the said advantages to learners, unless educational content, pedagogy and assessment methods are carefully selected and well integrated into the games themselves.

II MODEL FOR DESIGNING EDUCATIONAL DIGITAL GAMES

This study is initially based on research on current state-of-the-art game designs. A model design based on game design and instructional design approaches has been developed and implemented in this research study. This study aims to provide significant enhancements for placing educational content in games and developing educational games that are appropriate for learners' educational level.

As shown in figure 1, the proposed model is separated into two processes. Each process is described by a number of blocks representing scopes and attributes. The first process is to identify educational digital games by three entities, i.e., levels of education, fields of education, and game platforms. This information is necessary for both educators and game designers. The second one is the mapping process. Input from a collaborative crew of educators and game designers is solicited and afterwards mapped onto its matching elements in 7 aspects. For instance, fields of education will be mapped onto game genres and test/quiz will be mapped onto game quest. The mapping process model was designed to help both educators and

game designers gain a better understanding of the production process in order to develop effective educational digital games that can keep students' learning and engagement at a high level. In this study, investigation and a comprehensive review were carried out in three sections, i.e., identifying the educational digital game by levels of education, fields of education and digital game platforms respectively.

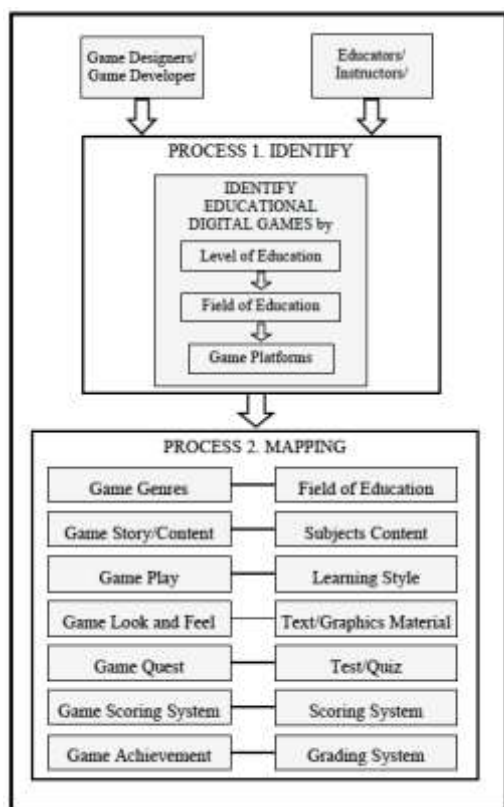

Figure 1. A Model for Designing Educational Digital Games

III IDENTIFY EDUCATIONAL DIGITAL GAMES BY LEVELS OF EDUCATION

The structure of educational system in figure 2 illustrates that educational digital games can be used as supporting tools for learning ("ISCED," n.d.). Levels of education are related to gradations of learning experiences and required competencies of participants. The levels of education in the diagram were arranged for assisting both educators and game designers to recognize the educational digital games before production. The levels of education are referenced from the UNESCO's International Standard Classification of Education. Several studies have already shown that diverse educational digital games were used in different levels of education to assist and support students in learning

aspect (Halverson, Shaffer, Squire, & Steinkuehler, 2006; Kiili, 2005; Rapeepisarn, 2012; Squire, 2008). Therefore, it is significant and essential to understand and recognize the levels of education, so that it can assist and facilitate both educators and educational digital game designers to design and develop applications for all levels including special needs schools.

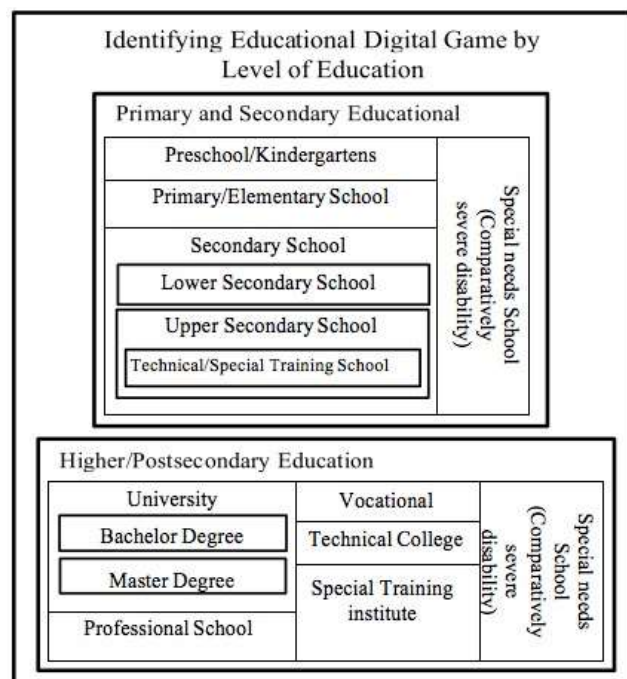

Figure 2. Identifying Educational Digital Games by Levels of Education

IV IDENTIFY EDUCATIONAL DIGITAL GAMES BY FIELDS OF EDUCATION

Identifying educational digital games by fields of study is another basis for design and developing educational digital games. Table 1 shows the selected ten fields of study based on information from the International Standard Classification of Education (ISCED) by UNESCO ("ISCED," n.d.). However, each group can be divided into several subfields. For example, in the fifth group, Science has four groups related to life sciences, physical sciences, mathematics and statistics, and computing. Although it is not shown in the table, in life sciences, there are many subjects in this field such as biology, botany, bacteriology, toxicology, microbiology, zoology, entomology, ornithology, biochemistry and etc.

Table 1. Field Of Education

Fields of Education	
1. General Programs	<input type="checkbox"/> Literacy and numeracy <input type="checkbox"/> Personal development
2. Education	<input type="checkbox"/> Teacher training and Education science
3. Humanities and Arts	<input type="checkbox"/> Arts <input type="checkbox"/> Humanities
4. Social sciences, business and law	<input type="checkbox"/> Social and behavioral science <input type="checkbox"/> Journalism and information <input type="checkbox"/> Business and administration <input type="checkbox"/> Law
5. Natural sciences, mathematics and statistics	<input type="checkbox"/> Life sciences <input type="checkbox"/> Physical sciences <input type="checkbox"/> Mathematics and statistics <input type="checkbox"/> Computing
6. Information and Communicati on Technologies	<input type="checkbox"/> Computer use <input type="checkbox"/> Database and network design and administration <input type="checkbox"/> Software and applications development and analysis
7. Engineering, Manufacturing and Construction	<input type="checkbox"/> Engineering and engineering trades <input type="checkbox"/> Manufacturing and processing <input type="checkbox"/> Manufacturing and
8. Agriculture	<input type="checkbox"/> Agriculture, forestry and fishery <input type="checkbox"/> Veterinary
9. Health and Welfare	<input type="checkbox"/> Health <input type="checkbox"/> Social services
10. Services	<input type="checkbox"/> Personal services <input type="checkbox"/> Transport services <input type="checkbox"/> Environmental protection <input type="checkbox"/> Security services

The use of educational digital games in each field of educational has reported to be on the rise. However, it should be noted from table 1. that there are some fields of education that cannot be classified into any specific group (“ISCED,” n.d.). By understanding and identifying the fields of education will assist both educators and game designers to provide appropriate content suitable for the relevant learning objectives in the pre-production stage.

V IDENTIFY EDUCATIONAL DIGITAL GAMES BY DIGITAL GAME PLATFORMS

A. Non-Portable Platforms

PCs, Game Consoles and custom devices are examples of non-portable game platforms. Educators and game designers can consider which platform to be used. PCs have the benefits of having a wide range of application software available (Rapeepisarn, Pongphankae, Wong, & Fung, 2008). Production of educational digital games on PC platforms can also be supported by a wide variety of input devices. Furthermore, they are more commonly used in most educational institutes. On the other hand, game consoles and custom devices are less commonly used in the educational sector. In addition, the development costs on game consoles and custom devices are higher than the development costs on PCs.

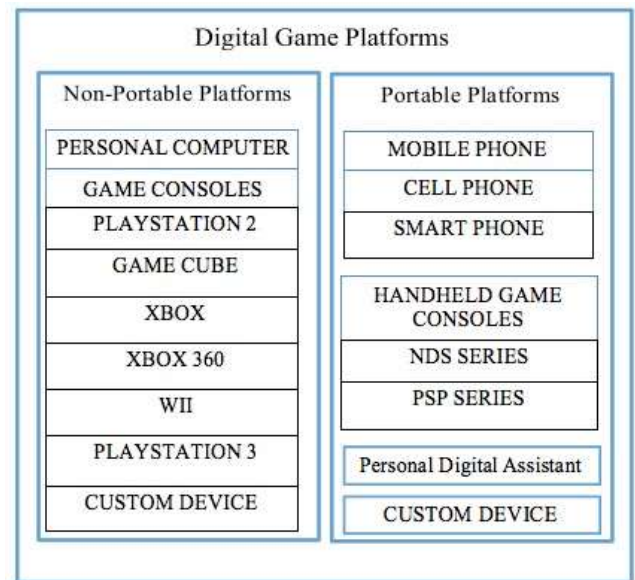

Figure 3. Digital Game Platforms

B. Portable Platforms

Mobile phones, handheld game consoles, and custom devices are examples of portable platforms. They are more popular for educational digital games. Currently, mobile phones, PDAs, handheld game consoles and custom devices are not only just communication or entertainment devices but they are emerging to become an important educational tool. The benefits of portable digital game platforms are that they come in small sizes, are portable, and easy to use and most teenagers are familiar with these devices. Furthermore, they have already been used as learning tools in many schools (Rapeepisarn, 2012; Whitton & Moseley, 2012).

VI METHODOLOGY

In this research study, the data of educational game applications in mobile platforms have been gathered particularly from the Apple App Store and the Google Play Store. 400 educational digital games were specifically selected from popular applications in

educational game category. Initially, 200 educational digital games were picked from the Apple App store while another 200 games ("Educational - App store Downloads on iTunes," 2016) were chosen from the Google Play Store ("Google Play," n.d.). They were then classified again into specific groups in the designed framework. According to the authors' research, the result shows that, there were only 286 out of 400 games from the initial selection that fit well into the constructed models. Game genres including the age range of game players which were between 4 and 12 years old were clearly defined in each selected game. Moreover, it reveals that the role playing game was ranked first among game genres in number of applications. The game content was mainly about arts, linguistics, mathematics, and occupation simulation. Since each game had defined its target audience using player age, they were then mapped onto appropriate levels of education in the designed framework. It was found that most games were designed for players at pre-school and primary school levels.

The model for designing educational digital game was able to assist both game designers and educators in developing games that can accurately target the right audience while the subject content is still appropriate for the learners. Moreover, the number of steps during the project planning and data collection process could be reduced in game development production. Game designers can simply determine appropriate game genres for educators' subjects content and precisely define their target audience. Consequently, game design and development for education can be implemented in the right direction according to the model recommendation.

VII CONCLUSION

It is proposed that a model for production of educational digital games will be beneficial not only for educators and game designers, but also for the digital game industry and education sectors on the whole. Use of educational digital games in the education sectors is already increasing. This study is working in the first phase concerning identification of different levels of education, fields of study, and game platforms. Investigation on the use of educational digital games in other aspects is currently under further exploration and development so as to

make the model to be more effective and flexible. During the next phase of this study, the framework is aimed to be further developed to be an expert system providing suggestions to digital game designers and educators in making their games more interesting while still enhancing the learning performance of students. More importantly, the games developed using the proposed model can provide useful feedback for the future improvement of this model.

REFERENCES

- Halverson, R., Shaffer, D., Squire, K., & Steinkuehler, C. (2006). Theorizing Games in and Education. In *Proceedings of the 7th International Conference on Learning Sciences* (pp. 1048-1052). Bloomington, Indiana: International Society of the Learning Sciences. Retrieved from <http://dl.acm.org/citation.cfm?id=1150034.1150231>
- Carina, G. (2012). *Student Usability in Educational Software and Games: Improving Experiences*. IGI Global.
- Chang, M., Hwang, W.-Y., Chen, M.-P., & Mueller, W. (2011). *Edutainment Technologies. Educational Games and Virtual Reality/Augmented Reality Applications: 6th International Conference on E-learning and Games, Edutainment 2011, Taipei, Taiwan, September 7-9, 2011, Proceedings*. Springer Science & Business Media.
- Foreman, J. (2003). Next-Generation Educational Technology versus the Lecture. *EDUCAUSE Review*, 38(4).
- Prensky, M. (2004). *Digital Game-Based Learning*. McGraw-Hill Pub. Co.
- Rapeepisarn, K. (2012). *A Framework for Adopting Educational Computer Games in the Undergraduate Courses in Thai Universities for Learning and Teaching*. Murdoch University. Retrieved from <http://researchrepository.murdoch.edu.au/10146/>
- Squire, K. D. (2008). Video game-based learning: An emerging paradigm for instruction. *Performance Improvement Quarterly*, 21(2), 7-36. <http://doi.org/10.1002/piq.20020>
- Aldrich, C. (2003). *Simulations and the Future of Learning: An Innovative (and Perhaps Revolutionary) Approach to e-Learning* (1 edition). San Francisco: Pfeiffer.
- Rapeepisarn, K., Pongphankae, S., Wong, K. W., & Fung, C. C. (2008). A comparative study of digital game platforms for educational purposes. In *Ninth Postgraduate Electrical Engineering and Computing Symposium, (PEECS2008)* (pp. 37-40). University of Western Australia. Retrieved from <http://researchrepository.murdoch.edu.au/769/>
- Kili, K. (2005). Digital game-based learning: Towards an experiential gaming model. *The Internet and Higher Education*, 8(1), 13-24. <http://doi.org/10.1016/j.iheduc.2004.12.001>
- Gros, B. (2007). Digital Games in Education: The Design of Games-Based Learning Environments. *Journal of Research on Technology in Education*, 40(1), 23-38.
- ISCED: International Standard Classification of Education. (n.d.). Retrieved December 20, 2015, from <http://www.uis.unesco.org/Education/Pages/international-standard-classification-of-education.aspx>
- Educational - App store Downloads on iTunes. (2016). Retrieved January 24, 2016, from <https://itunes.apple.com/us/genre/ios-games-educational/id7008?mt=8>
- Google Play. (2016). Retrieved January 20, 2016, from <https://play.google.com/store>
- Whitton, N., & Moseley, A. (2012). *Using Games to Enhance Learning and Teaching: A Beginner's Guide*. Routledge.

Knowledge Management Initiatives in Contact Centre: A Case Study in Tenaga Nasional Berhad

Siti Rafidah Mukiar¹, Nor'ashikin Ali², Rabiah Eladwiah Abdul Rahim²

¹Tenaga Nasional Berhad, Malaysia, rafidahmu@tnb.com.my

²Universiti Tenaga Nasional, Malaysia, {shikin;rabiah}@uniten.edu.my

ABSTRACT

This paper reports the results of a qualitative study of KM in World Class Contact Centre (WCCC) of Tenaga Nasional Berhad (TNB). This study uses data collected through interviews, discussions and documents obtained from managers and agents of WCCC as well as observations of the WCCC operation. Through these initiatives, several outcomes have been identified that bring benefits to the agents such as the increase in knowledge competency, up-to-date information, and improved level of confidence of contact centre agents. WCCC received many awards from internal and international association as a result of their effort in providing a world class customer service to their customers, which can be observed through the Customer Satisfaction Index (CSI) score.

Keywords: Knowledge Management, Contact Centre, Implementation,

I INTRODUCTION

The view that knowledge is as critical as other assets such as land, property, labour, and cash leads to the wide acceptance of knowledge management (KM) in most business organisations such as 3M, Hewlett-Packard, Xerox and Buckman Labs (Bhatt, 2001). Although knowledge has been acknowledged as a source of competitive advantage, it has not been managed well in many organizations. A study by Takeuchi (1998) on a poll of executives from 80 large companies in the U.S. found that only a few executives felt that they managed their knowledge well. As a result, the organization may lose its competitive advantage where the knowledge was not captured, stored, re-used and shared properly.

Accordingly, within the operation of a contact centre, it is a rule of thumb that agents must have sufficient knowledge to provide the best services to their customers. Agents in a contact centre must convey accurate information about the organization, especially in an electricity utility company, where the supply of electricity is vital to the daily operation of individuals or even business and industrial consumers. Accurate and comprehensive information with regards to the electricity supply will help to describe the general information, the business plan and the operation and production schedule of the

company. For this reason, KM initiatives are important to be implemented in the contact centre to ensure that knowledge will be managed systematically and agents can perform to their best capability which will translate to the satisfaction of the customers.

This paper aims to explore the current KM initiatives implemented in the contact centre of TNB. This study will include the identification of the KM activities in the contact centre and how the KM activities produce impacts to the contact centre. Outcome from this study can be a guidance to help other contact centres in applying KM in their organization.

II LITERATURE REVIEW

In an organization, it is common that senior workers possess high levels of tacit knowledge, which are accumulated through their working experience and learning process (Debowski, 2005). Knowledge is considered as a renewable and re-usable asset, which is valuable to a firm and is enhanced with an employee's experience (Masa'deh et al, 2015). The value of knowledge can be enhanced only if knowledge is shared, reused and applied amongst workers so as to generate creative ideas to overcome existing problems or challenges ahead.

Knowledge, being a valuable commodity in an organisation, is considered the most strategically resource of an organisation. Thus, it is viewed as a determinant of sustained competitive advantage and superior corporate performance (Takeuchi, 2013). This views echoes the view of Peter Drucker, who mentioned that the organisation can make the future by turning intellectual assets into value through innovation. Only through innovation, organisations can sustain its competitive advantage and strive for a superior performance (AL-Hayaly, 2016). Thus, KM has become the solution to many organisations in leveraging organisational knowledge. However, not all KM initiatives are successful due to the perception that KM is a silver bullet—that is just the implementation of information technology. In managing knowledge in a firm, Tobin (2003) discusses ten principles for KM success: KM is a discipline, one champion is not enough, cultural change is not enough, cultural change is not - automatic, create a change management plan, stay strategic, pick a topic, go in depth, keep it current,

don't get hung up on the limitations, set expectations or risk extinction, integrate KM into existing systems and educate your self-services users. While these principles are important for the success of KM, they have lagged practice. Using these KM principles as guidance, we explore the KM initiatives in the contact centre of TNB with the aim to identify the impact of KM in the contact centre and how KM can be improved.

III METHODOLOGY

This study aims to identify the KM initiatives carried out in a contact centre. A literature review was done about KM to establish a baseline for the study. Semi structured interviews and discussions with managers and agents in WCCC were conducted to explore and deepen the KM initiatives that have been implemented and its effectiveness to all agents and managers in WCCC. Data collection and analysis was done to the documents related with KM initiatives such as implementation plans, schedule training, training plan for each level of employees for the Customer Operation Performance Certificate (COPC), example of exam papers, the record evaluation results forms and shift schedule of its agents to gain better understanding of the contact centre operations. The process of observing the WCCC operation includes the agents' method on how to manage calls from customers, the systems used and the quality monitoring system.

IV KM IN CONTACT CENTRE

A successful implementation of KM in an organization may improve the company's performance by becoming more competitive and able to maintain its prominence towards its customers. As mentioned earlier, KM implementation is very crucial to be carried out in a contact centre of an electricity utility company, especially in WCCC, TNB. The main purpose of the study, which was carried out in April 2016, was to investigate on how the KM is being implemented and what are the initiatives that contribute to the success of the implementation. In overall, the results from the case study are organised into three parts as follow:-

- (i) Company Background
- (ii) WCCC
- (iii) KM Initiatives

A. Company Background

TNB is the largest electricity utility provider in Malaysia with asset totalling to RM110.7 billion. TNB have been entrusted by the Government of Malaysia to supply electricity throughout Peninsular Malaysia and also to Sabah and Labuan through its subsidiary company, Sabah Electricity Sdn. Bhd. There are three (3) core businesses in TNB which are

regulated by the Energy Commission (*Suruhanjaya Tenaga*). First is the generation of electricity through many means such as hydro dams and gas and coal fuelled generation stations. Second is the transmission from the generation stations to the distribution stations. Lastly is the distribution of electricity to all of its customers.

Besides that, TNB is also involve in unregulated businesses through its subsidiaries such as in the sector of manufacturing, installation, repair and maintenance of transformers, high-voltage switchgears & cables and professional consultation services related to architectural, civil, electrical engineering works and services in Malaysia, Mauritius, Pakistan, India and Indonesia. As a complement to the core businesses, TNB Research has been established as a subsidiary of TNB to research and develop new technologies to improve, sustain, nurture and promote innovations related to all TNB's operations and businesses. In the education sector, TNB has established Universiti Tenaga Nasional (UNITEN) to develop high quality graduates which will be beneficial not only to TNB as a source for future human capital but also to the country by increasing the education level of its people.

B. World Class Contact Centre (WCCC)

Customer satisfaction is the top priority in providing service to the customer and to ensure business excellence in TNB as a world-class company. For that purpose and to support the TNB's core businesses, the WCCC formerly known as TNB CareLine has been established as an initiative to improve the customer's experience, operational efficiency and customer's transaction virtually.

Previously, there was only one unit in TNB responsible for the call centre namely Call Management Centre (CMC) with its one-number direct line, 15454. CMC was in charge in receiving complaints regarding power outages and malfunction streetlights. Once received, they will convey the complaints to the respective units for any applicable restoration works. CMC operates 24 hours a day and 7 days a week throughout the year. Starting in 2011, another wing of the call centre which was called the One Stop Engagement Centre (OSEC) was established to manage any inquiry regarding TNB services such as electricity bills, tariff rates, electricity disconnections, payment enquiries, self-meter reading and cheque verification for any payment using kiosk. OSEC only operate in two shifts, which the shifts rotate for 16 hours a day and 7 days a week using the phone line 1-300-88-5454. CMC and OSEC managed an average of 275,000 calls per month.

Starting in 2012, as a step to boost the customers' satisfaction, WCCC was established and had added 4 more channels to manage all customers' inquiries including Social Media, WebChat, Email and SMS. In the future, the existing channels will also be integrated with Virtual Agent, IVR Self-Services, PKP (Retail), MyTNB, E-Services, Corporate Website and Kiosk.

CMC and OSEC agents are trained to be the expert regarding any services in TNB. KM initiatives need to be implemented in WCCC to ensure that the agents will be competence enough to perform their duties in the contact centre.



Figure 1. All Channels of Communication in WCCC

C. KM Initiatives In WCCC

The most important assets in the WCCC are the skilled and highly competence agents which are the backbone of the centre. WCCC agents must be proficient in both dimensions of skills which are the technical know-how and the soft skills in human interaction. The KM initiatives that have been implemented in the WCCC are as follow: -

1. Basic Training for New Agents

For new agents to start their duties and perform to their fullest potential, it is important for each agent to understand the basic knowledge about TNB and their deliverables in WCCC. New agents will undergo 15 days of initial training modules, which consists of 12 days of training in ILSAS and 3 days On-Job-Training (OJT). The purpose of the training is to provide the basic knowledge about TNB to the new staffs before performing their duties. This training will cover the following topics:-

- Basic technical knowledge.
- Application system that will be used such as Sistem Maklumat 1 TNB (SMIT), Total Outage Management System (TOMS) dan e-Customer Information Billing System (e-CIBS).
- Electricity bill calculation, principles and components such as maximum demand charge, energy charge, power factor surcharge, Good and Service Tax (GST), Imbalance Cost Pass Through (ICPT), Minimum Monthly Charge (MMC), tariff, Kumpulan Wang Tenaga Boleh

Baharu (KWTBB), late payment penalty and welding charge.

- Product information and website such as K-Portal, e-Services, MyTNB, Kiosk, Autopay and PSI.
- Processes and principles related to the customer's affairs such as new connection, change of tenancy, temporary supply, supply application online, deposit, upgrading, disconnection and Personal Data Protection Act (PDPA).
- Customer service information which includes methods to handle customers, ethical communication skills, techniques for dealing with difficult calls and good telephone etiquette.

During the OJT, new agents will manage actual calls while their supervisor will supervise and coach the agents to improve their skills and confident level. Supervisor will also assess their capability in delivering the specified jobs within the standard required. If the agents cannot meet the standard, they will need to be retrained. New agents will amass the required knowledge throughout the training by combining explicit knowledge from the 15 days session and the tacit knowledge from their supervisor during the OJT.

2. Continuous In House Training for Existing Agents

To ensure that the service excellence in every existing agent are consistently updated with new information, circulars and applications, continuous in-house training for existing agents will be done periodically. Due to limited number of agents coupled with different shift schedules, training is not feasible to be carried out in ILSAS. The training unit provides an annual training schedule whereby each agent must attend three training sessions which each training session would last for a week. Each agent will take turns to give a briefing on the existing policy, while the Business Process Owner (BPO) or Subject Matter Expert (SME) will come to WCCC to give a briefing and training about new policies, circulars or applications. This training which focuses on information sharing and distribution are important as a knowledge exchange platform between agents, BPOs and SMEs.

3. English Language Course

To Exceed Customer Satisfaction is the second goal from the five Key Results Area (KRA) of the TNB's Transformation Program. The target is to improve the customer touch points, channels, products and services with one of the initiatives is to make the call centre multilingual. To achieve the objective of managing and enabling customer calls from different nationalities, WCCC agents must be able to

understand, write and communicate in English. External trainer has been appointed to provide English courses to all WCCC agents.

4. Soft Skills Training

Soft skills are required during interactions with a customer. It can be related to the language use, the tone of voice and the clarity of voice and explanation. The soft skills applied by the agents will leave positive impact to influence the customers' experience and satisfaction. Through the realization of soft skills, customers will feel comfortable when dealing with the agents, who are projected as professional, compassionate, concerned and showed a sincere desire to help. The agents will be trained on how to use the soft skills in dealing with different type of customers. With this training, agents will learn the best techniques to deal with difficult calls, words and phrases to avoid, good telephone etiquette, active listening to gather appropriate information and how to handle calls in a professional and caring manner.

5. Customer Operation Performance Certificate (COPC)

COPC Inc. offers certification of the COPC® Family of Standards, which certifies WCCC's management personnel and agents having a proven, comprehensive framework for managing customer experience. Each COPC Standard focuses on best practices regarding people, processes, and performance that will drive excellence in the customer related operations. Certification to a COPC Standard enables WCCC to measure and improve all operational activities to enhance customer experience.

For this purpose, the Training Unit has developed several training modules and development plans for each individual in the management level and every front liner agents. Each person need to go through examination process once in every 3 months. If they fail, they need to review back the modules and retake the test.

6. Employee Engagement

Previously, whenever there was a revision on electricity tariffs, Tariff Unit need to set up an operation room to answer all questions regarding the revision of tariffs and other related matters such as pro-rate calculation based on the electricity bill of the customers. Tariff Unit had to manage on their own and it had disrupted their daily deliverables.

As a step to enhance OSEC's knowledge on tariff, during the tariff revision in 2009, OSEC agents were invited to take turns to be on duty in the tariff operation room to get exposure on how to answer questions and manage tariff inquiries. The

collaboration between the OSEC agents and BPOs will ensure that the knowledge transfer will happen smoothly by BPOs sharing the tacit and explicit knowledge with OSEC agents.

During tariff revision in 2011, 50% of the responsibilities in the tariff operation room were handled by the OSEC staffs and the latest in 2014, 70% of the responsibilities in the operation rooms were handled by the OSEC agents. The operation room was only opened for a short period of time and after it was closed, all inquiries were handled by the OSEC team. The OSEC team will only refer to BPOs if there is a new type of inquiry from the customer.

7. Quality Monitoring Unit

Quality Monitoring (QM) Unit's role is to check and monitor the agents' performance whether they comply with the standard in managing phone calls. QM will monitor by listening to the conversation in three situations, namely a recorded conversation, live conversation or even being next to the agents during live conversation. Result from the QM monitoring will determine whether the agents have complied with the stated standard or further training are required. QM may also on their own initiative to directly train the agent while being next to the agents during live conversation. QM may have big influence especially to the new agents.

8. Standardized Performance Management Through Circulars and Procedures in PSI and e-Doc

All the circulars and procedures will be approved by the Top Management of TNB and are documented in the Process Standardization and Improvement (PSI) Portal as well as the e-Doc Portal. BPOs will present the related items to the agents through in-house training to update their knowledge. BPOs will then explain in great details about the new circulars or procedures.

PSI Portal is the online database to keep all procedure documents while e-Doc Portal stored all circular documents. WCCC agents can easily and quickly obtain any policies or procedures throughout these two online portals. Systematic documentation in PSI and e-Doc Portal also can ensure the security of document storage.

9. Structured Frequent Ask Question

BPOs and SMEs will produce a predictable Frequent Ask Question (FAQ) that will always be asked by employees or customers. FAQ will be updated and improvised with questions that were collected during the road shows, trainings and hand-holding sessions.

As an example, any tariff revision undertaken by TNB is subject to the approval of the Malaysian

Government because most of TNB's operations are regulated by the Energy Commission. Any related components to be included in the electricity bills such as Imbalance Cost Pass Through (ICPT), Renewal Energy Fund (KWTBB) and Subsidized Fuel Cost (*Subsidi Bahan Api*) need to be endorsed by the Government.

For every tariff revision or any new direction instructed by the Government, TNB will need to review the circulars, arrange road shows, organize trainings and hand-holding sessions and prepare the FAQs to ensure the information is delivered and transferred to all employees and customers.

WCCC agents are trained to be the expert regarding any TNB services. Therefore, FAQ list is a powerful asset to CMC and OSEC in providing accurate and standard answer to the customers. The CMC and OSEC staffs should be well versed with FAQ to easily manage customers' queries.

10. Knowledge Portal (K-Portal)

Knowledge Portal, also known as K-Portal provides a platform for additional information or explanation to the circulars or procedures that are being shared with all employees. K-Portal mainly provides the employees on information regarding customer services. Slide presentations, FAQs or videos are the example of materials available in the K-Portal. Around 600 FAQs have been developed by the BPOs and SMEs are stored in the online K-Portal. The BPOs and SMEs will share their knowledge and expertise by updating the K-Portal whenever needed.

Due to current social media phenomena, TNB have also established the TNB Careline's Facebook to cater the need of customers who would choose to make a complaint through social media. A dedicated team has been appointed to manage the TNB Careline's Facebook as well as to responds to any enquiry or complaints made any the customer.

V FINDINGS AND DISCUSSION

A. Benefits

One of the benefits of implementing KM is that the new agents can begin their duties immediately after completing the 15 days of basic and on-the-job training which they will utilize all information stored in PSI Portal, e-Doc Portal and K-Portal. The circulars, procedures and FAQs can easily be accessed instantly from the portals. New agents can find answers to common questions easily by themselves without having to constantly refer to their supervisor, thus conversation time with customers will be reduced and the customer's problem will be solved promptly while the supervisor can focus on other challenging issues.

By implementing continuous in-house training, existing agent are consistently updated with new information while at the same time can reduce agent training time which is tied with shift schedules. It also can reduce training cost and focus to knowledge sharing and exchange directly from BPOs and SMEs.

Continuous competency development for each agent through English course and soft skills training will cultivate effective communication skills, high confident level, able to produce accurate explanations, better time management during session with customers and excellence in problem solving.

Agents who have been certified by COPC Standard can increase their job-marketability value and are eligible to serve in any call centre. For the management personnel who have been certified by COPC Standard will be eligible to give consultation work to other companies to set up their own call centre.

Tacit knowledge from supervisor will be shared and transferred to agents during OJT, employee engagement such as during tariff operation room and coaching by QM. The standardisation of circulars and procedures and the establishment of FAQs will give a better understanding to the agents to deliver quick and correct answers to the customers. The reduction in conversation time will also improve customers' satisfaction and increased cost savings.

B. Success Factors

One of the success factors of the KM implementation in WCCC is the full support from the management which includes ample allocation of resources, good leadership and adequate training. Without full and continual support from the management, KM may not be functioning well. The second factor is the commitment and motivation from employees and management which drives the steadiness of the KM implementation. The commitment from the employees will make sure that the KM activities being executed efficiently. The third element is the integrated technical knowledge infrastructure which covers management information system, database and repositories such as K-Portal, PSI Portal and e-Doc Portal, networks, softwares and computers. User friendly system that can be easily access by employees and is always updated will support the KM implementation. Furthermore, a positive organization structure and culture that support sharing, learning and re-use of knowledge are also the factor for success.

C. Awards and Recognitions

As a proof of service excellence WCCC, some of the prestigious awards and recognition received by WCCC are as follow: -

- a) Asia Geospatial Excellence Award for Application of Geospatial Technology in Electricity for Implementation of Smartview for Outage Management in TNB Distribution in GE Smart Asia 2015.
- b) Silver Award in Best Customer Experience Delivered in CCAS Contact Centre Award 2014 awarded by Contact Centre Association of Singapore (CCAS).
- c) 3rd Place in Best Contact-Centre Utilities (open) in 15th National Customer Experience Industry Award 2014 awarded by Association of Customer Experience Industry of Malaysia (ACE).
- d) Gold Service Award in CRM Programme Implementation Contact Centre (open);
- e) Gold Service Award in Technology Innovation Contact Centre (open); and
- h) Silver Award in Best Video for Contact Centre (open) in Excellence Award 2010 awarded by CCAM.
- i) Best Emerging Contact Centre (GLC Category) in Excellence Award 2007 awarded by CCAM.

D. Customer Satisfaction Index (CSI) Score

Customer Satisfaction Index (CSI) is a survey that measures customer's satisfaction towards TNB services. Before 2013, CSI was conducted by Customer Service Department, Distribution Division, TNB once in every 2 years until the management has decided to do it annually. By tracking it annually, the CSI will assist TNB on planning to further improve customer satisfaction towards TNB by enhancing or adding the initiatives. Based on the improvements made by WCCC in beginning of 2011 with the establishment of OSEC as well as additional channels in 2012, the CSI Score is moving towards the upward trend and recently for financial year of 2015, TNB manage to achieve the score of 8.0. Refer to Figure 2 as shown below.

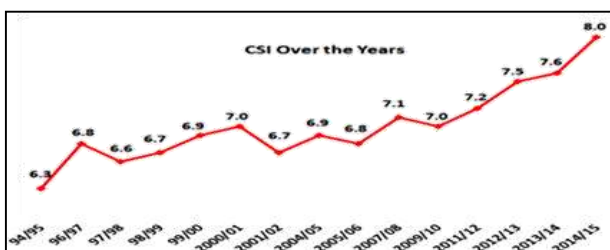

Figure 2: CSI from year 1995 to 2015

VI CONCLUSION

This paper has presented the findings of a case study to investigate the implementation of KM in WCCC, TNB. All KM initiatives as well as its benefits have been comprehensively described. In addition, the

implementation of a systematic KM has contributed to the customer satisfaction with the increase of CSI Score whereby TNB manage to achieve 8.0 score and WCCC is recognised locally and even globally. Furthermore, with the vision "To be among the leading corporations in energy and related businesses globally", TNB is always committed to be excellent in their products offering and services. TNB have ensured that TNB must always grow and innovate itself. Thus, implementation of KM in the WCCC is very important and requires support from the management and full cooperation from all the employees. This study can serve as a reference for other contact centre in KM implementations and to build up an effective contact centre. With the realisation of systematic KM, contact centre agents are able to become confident and competent. It will also reduce conversation time, faster problem solving and speed up new agents development.

ACKNOWLEDGMENT

The author would like to thank WCCC, TNB for giving their support by sharing relevant information related to the KM implementation. Special thanks to the lecturers from Universiti Tenaga Nasional which have given their best guidance in accomplishing this study.

REFERENCES

- AL-Hayaly, M.A.M.S. & Alnajjar, F.J.S. (2016). Knowledge Management Process and Their Impact on Organizational Performance, the Adoption Balanced Scorecard: The Moderating Role of Quality Assurance Standards – An Applied Study on Private Jordanian Universities.
- Alavi, M. (1999). Knowledge Management Systems: Issues, Challenges And Benefits.
- Berends, H., Vanhaverbeke, W. & Kirschbaum, R. (2007) Knowledge Management challenges in new business and development: Case study observations.
- Bhatt, G. D (2001), "Knowledge management in organisations: examining the interaction between technologies, techniques, and people", *Journal of Knowledge Management*, Vol. 5, No., 1, pp. 68-75.
- Calopa, M.K., Horvat, J. & Kuzminski, L. (2015). The Role of Human Resource Management Practice Mediated by Knowledge Management (Study on companies ICT sector, Croatia).
- Debowski, S., 2005. Knowledge Management: A Strategic Management Perspective.
- Forcadell, F.J. & Guadamillas, F. (2002). A Case Study on the Implementation of A KM Strategy Oriented to Innovation.
- Ling, C.T.N. (2011). KM Acceptance: Success Factors amongst Small and Medium-Size Enterprise.
- Masa'deh, R.M.T., Obeidat, B.Y., Al-Dmour, R.H. & Tarhini, A. (2015). Knowledge Management Strategies As Intermediary Variables Between IT-Business Strategic Alignment And Firm Performance.
- Wong, K.Y. & Aspinwall, E. (2006). Development of a knowledge management initiative and system: A case study.
- Takeuchi, H., (2013) Knowledge-Based View of Strategy, *Universia Business Review*, Cuarto Trimester, ISSN:1698-5117
- Tobin, T. (S2003). Ten Principle for Knowledge Management Success.

A Study on the Effects of Window Size on Electrocardiogram Signal Quality Classification

Tanatorn Tanantong

Rangsit University, Thailand, tanatorn.t@rsu.ac.th

ABSTRACT

The sliding window-based method is one of the most used method for automatic Electrocardiogram (ECG) signal quality classification. Based on this method, ECG signals are generally divided into small segments depending on a window size and these segments are then used in another classification process, e.g., feature extraction. The segmentation step is necessary and important for signal classification and signal segments with different window sizes can directly affect the performance of classification. However, in signal quality classification, the window size is often randomly selected and further analysis on the most appropriate window sizes is thus required. In this paper, an extensive investigation of the effects of window size on signal quality classification is presented. A set of statistical-amplitude-based features widely used in the literature was extracted based on 10 different window sizes, ranging from 1 to 10 seconds. To construct signal quality classification models, four well-known machine learning techniques, i.e., Decision Tree, Multilayer Perceptron, k -Nearest Neighbor, and Naïve Bayes, were employed. The performance of the quality classification models was validated on an ECG dataset collected using wireless sensors from 20 volunteers while performing routine activities, e.g., sitting, walking, and jogging. The evaluation results obtained from four machine-learning classifiers demonstrated that the performance of signal quality classification using window sizes of 5 and 7 seconds were good compared with other sizes.

Keywords: Electrocardiogram (ECG) signal, ECG signal quality classification, wireless monitoring systems, signal segmentation, window size.

I INTRODUCTION

Electrocardiogram (ECG) signals describe electrical activities of the human heart and they are primarily used in diagnosis and treatment of cardiovascular diseases (Catalano, 1993; Hampton, 2008; Norman, 1992). However, in data acquisition, especially in continuous monitoring, ECG signals are often corrupted by several types of noises, e.g., motion artifact, power line interference, and baseline drift noises (Clifford, Azuaje, & McSharry, 2006). Such

noises considerably affect the quality of ECG signals and lead to high false cardiac alarm rates in intensive care units (Schmid, Goepfert, & Reuter, 2013). Therefore, the assessment of the signal quality is also an important process and required for continuous ECG monitoring.

Several researchers have addressed issues related to assessing quality levels of ECG signals and have proposed an automatic approach for signal quality classification. In 2011, the Computing in Cardiology Challenge (Silva, Moody, & Celi, 2011) was arranged by PhysioNet, aiming to find some effective and efficient methods for classifying quality levels of ECG signals captured using mobile phones. The PhysioNet has also publicly provided an ECG dataset for evaluating methods of signal quality classification. The dataset consists of 2000 ECG signal recordings, 10 seconds long each, collected using mobile phones. Each signal recording was manually annotated by experts with three quality levels, “Acceptable”, “Unacceptable”, and “Indeterminate”. Based on this ECG dataset, several studies proposed automatic approaches for ECG signal quality classification using different techniques, for example, combination of rule-based and machine-learning-based methods (Kuzilek, Huptych, Chudacek, Spilka, & Lhotska, 2011), Ensembles of Decision Trees (Zaunseder, Huhle, & Malberg, 2011), a threshold-based rule (Hayn, Jammerbund, & Schreier, 2012; Johannesen & Galeotti, 2012). However, further investigation on the effects of window size on signal quality classification and further experiments on ECG signals continuously captured while subjects are performing a routine daily activity were required.

Studies on the effects of window size for signal classification has been also addressed many research area, e.g. detecting embolic signals using the Fast Fourier Transform (FFT) (Aydin, 2000), analyzing electromyography signals (Thongpanja, 2013), and classifying acceleration signals for human activity recognition (Banos, Galvez, Damas, Pomares, & Rojas, 2014). These studies demonstrated the importance of analyzing the window size in the signal processing and motivated further investigation on the window size impacts on classifying the quality of ECG signals.

This paper presents an extensive study on the effects of window size on signal quality classification. ECG

signals acquired using wireless devices from 20 volunteers while performing routine activities were used. Based on a sliding window technique, statistical-amplitude-based features were extracted from ECG signals relying on a defined window size. Four machine learning algorithms, i.e., Decision Tree, Multilayer Perceptron, k -Nearest Neighbor, and Naïve Bayes, were employed to construct classification models. In order to investigate the effects of window size on signal quality classification, each classification model was evaluated using a different set of window sizes. The rest of this paper is organized as follows: Section 2 provides related works. Section 3 describes the materials and methods used for automatic classifying quality levels of ECG signals. Section 4 reports evaluation results and discusses the effects of window size on signal quality classification. Section 5 presents conclusions.

II RELATED WORKS

A. ECG Signal Quality Classification

A combination of a rule-based method and a machine learning-based method (Kuzilek, et al., 2011) was proposed for ECG signal quality classification. A set of noise detection rules and a Support Vector Machine (SVM) classifier were employed for calculating a quality score of each signal recording based on statistical values of signal amplitudes and time-lagged covariance matrices. Using the signal quality scores determined from rules and SVM, an accuracy of 83.6% was achieved.

An automatic method based on Ensembles of Decision Trees (EDTs) for ECG signal quality classification was presented (Zaunseder, et al., 2011). In order to construct an EDTs classifier, frequency-domain features based on high frequency (45-250 Hz) and low frequency (0-0.5 Hz) noises in ECG signals, were used. The proposed method yielded an accuracy of 90.4%.

An algorithm for determining the quality of ECG signals (Johannesen & Galeotti, 2012) was developed, consisting of two steps: (1) exclusion of signal recordings with ECG-lead connection issues, using QRS complex information and (2) determination of signal quality levels of each recording, relying on noise type information. The two-step algorithm provided an accuracy of 90.0%.

Four quality measures based on empty lead, spike detection, lead-crossing point, and QRS-detection robustness criterion, were implemented in order to assess the quality of ECG signals (Hayn, et al., 2012). Using combination of these four measures, a good evaluation result was obtained for signal quality classification, with an accuracy of 91.6%.

In all above studies, the different methods for automatic signal quality classification were presented with high accuracy results on the PhysioNet ECG dataset. However, the effects of window size on signal quality classification and the experiments on ECG signals continuously captured while subjects are performing a routine daily activity were not yet investigated.

B. Window Size Effects in Signal Classification

An extensive study on the effects of window size in analysis and detection of embolic signals using the fast Fourier transform (FFT) was reported (Aydin, 2000). The embolic signals were acquired using a commercial Doppler ultrasonic system, EME Pioneer TC4040, with a frequency of 2 MHz. Based on the FFT technique, six dissimilar window sizes, 2.2, 4.4, 8.9, 17.9, 35.8, and 71.6 milliseconds, were employed for evaluating the effects of window size. The evaluation results showed that the FFT window sizes of 8.9 and 17.9 milliseconds were mostly suitable for detecting embolic signals.

For electromyography (EMG) signal processing, an investigation on impacts of window size on analyzing surface EMG signals (Thongpanja, 2013) was presented. In data collection, EMG signals were captured from 6 volunteers while they are performing 5 levels of lifting objects, weighed between 1 to 5 kilograms, and are performing a 5-second movement of elbow flexion and extension. Using six different window sizes, i.e., 125, 250, 375, 500, 750, and 1,000 milliseconds, EMG signals were segmented using a sliding window technique. For evaluation, the Modified Reverse Arrangement (MRA) test was adopted in order to assess the stationarity of EMG signal segments. The results demonstrated that 375 and 125 milliseconds were optimal values of window size for analyzing surface EMG signals for static and dynamic contractions, respectively.

In (Banos et al., 2014), a comprehensive study on the effects of window size on automatic human activity classification using acceleration signals was presented. In data acquisition, acceleration signals were captured from 17 subjects while they were performing 33 activities. Using different window sizes ranging from 0.25 to 7 seconds (in steps of 0.25 second) and a non-overlapping sliding window technique, three sets of statistical features including mean and standard deviation were extracted. Four machine learning algorithms, i.e., Decision Tree, k -Nearest Neighbors, Naïve Bayes, and Nearest Centroid Classifier, were employed to construct activity classification models. In order to evaluate the performance of each model, 10-fold cross validation and an F_1 score measure were used. From the obtained results, the highest performance of activity

recognition were achieved when using window sizes of 1 and 2 seconds.

All the studies mentioned above addressed the importance of selecting an optimal window size for analyzing and classifying different signals, i.e., embolic signals (Aydin, 2000), electromyography signals (Thongpanja, 2013), acceleration signals (Banos, et al., 2014). These studies motivated further investigation of the effects of window size on ECG signal quality classification.

III MATERIALS AND METHODS

A. Data Acquisition

In this study, ECG signals captured using wireless Body Sensor Networks (Yang, 2006) from 20 healthy volunteers, i.e., 10 young and 10 elderly volunteers, were used. The 10 young volunteers (7 males and 3 females, aged between 27-44 years) were asked to perform 16 daily activities, five times each, including standing, walking upstairs, up and down movement of both arms, and jogging. The 10 elderly volunteers (2 males and 8 females, aged between 57-71 years) were asked to perform 7 daily activities, five times each, e.g., sitting, lying, and walking. Lead-II configuration (Barill, 2005), which is usually applied for monitoring patients' ECG signals in Intensive Care Units, and a sampling rate of 100 Hz were employed for acquiring the signal recordings.

B. Signal Segmentation and Annotation

For signal segmentation, a non-overlap sliding window method (Banos, et al., 2014) was adopted in

this study. According to a report from the Association for Advancement of Medical Instrumentation (AAMI, 2002), an abnormal case in ECG signals should be reported within 10 seconds. This motivated time-period number was used as the maximum size value of ECG segments for classifying quality levels. In order to investigate the effects of the window size, 10 different window sizes, range of 1 to 10 second in steps of 1 second, were considered. ECG signals were divided into small portions based on the different window sizes as illustrated in Figure 1.

To annotate ECG signals with quality labels, the signal quality classification scheme (G.D. Clifford, Behar, Li, & Rezek, 2012) was applied. This scheme was used in several studies, focused mainly on classifying quality levels of ECG signals (Joachim, Julien, Qiao, & Gari, 2013; Li & Rajagopalan, 2014; Tanantong, Nantajeewarawat, & Thiemjarus, 2015). In this study, two suggested quality levels, "Low-quality" and "High-quality", were used for labelling entire ECG signals. Low-quality signals are the signals that are contaminated with high levels of noises and cannot be confidentially used for a physician's diagnosis. High-quality signals are the signals that are noiseless or contaminated with some little noises. In addition, for high-quality signals, the significant ECG signal components, e.g., P, Q, R, S, and T waves, must be completely identified. Table 1 shows the proportion of signal segments to quality levels in 10 different window sizes.

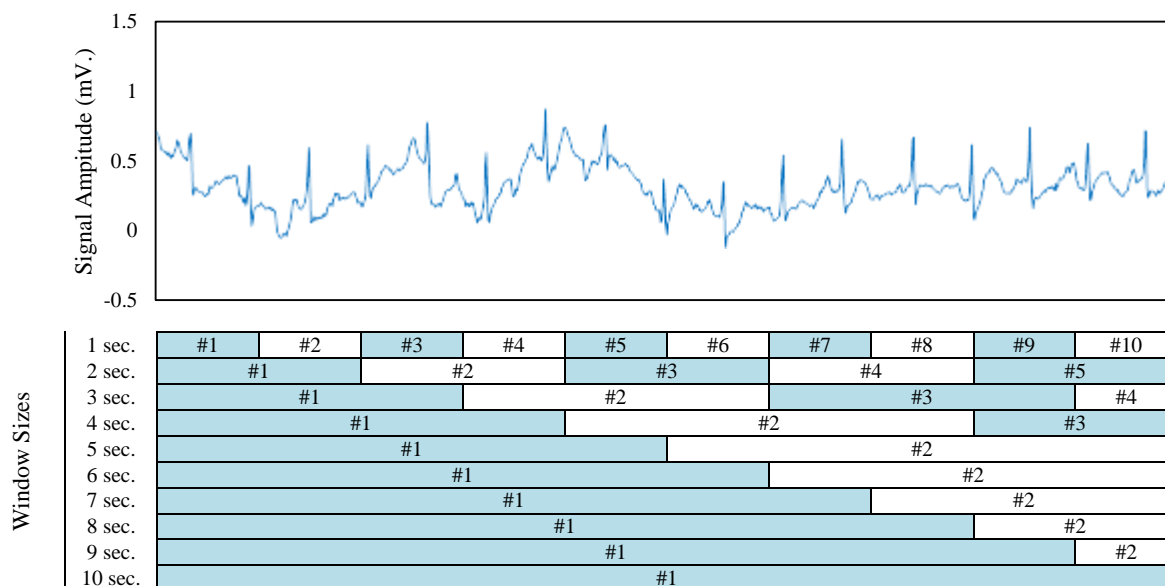

Figure 1. ECG Signals During Jogging (Top) and Examples of Signal Segments with Diverse Window Sizes (Bottom)

Table 1. No. of Segments in Each Window Size

Window Size (Second)	No. of Signal Segment		
	Low Quality	High Quality	Total
1	1850 (12.26%)	13237 (87.74%)	15087
2	944 (12.57%)	6567 (87.43%)	7511
3	598 (11.98%)	4395 (88.02%)	4993
4	460 (12.32%)	3273 (87.68%)	3733
5	374 (12.58%)	2600 (87.42%)	2974
6	301 (12.19%)	2168 (87.81%)	2469
7	266 (12.59%)	1847 (87.41%)	2113
8	221 (12.02%)	1618 (87.98%)	1839
9	200 (12.26%)	1431 (87.74%)	1631
10	185 (12.69%)	1273 (87.31%)	1458

C. Feature Extraction and Signal Quality Classification

Based on 10 different window sizes, four statistical-amplitude-based features, i.e., mean, variance, slope, and difference between maximum and minimum values of ECG signal amplitudes in each segment, were extracted. The number of all obtained features can be determined by the multiplication between the number of features and the number of segments in the defined window sizes (Referring to Table 1). Such features were also widely employed in several studies on ECG signal quality classification (Chudacek, Zach, Kuzilek, Spilka, & Lhotska, 2011; Johannesen & Galeotti, 2012; Kuzilek et al., 2011; Schumm, Arnrich, & Troster, 2012). To construct the signal quality classification model, four widely known machine learning techniques (Witten, Frank, & Hall, 2005), i.e., Decision Tree, Multilayer Perceptron, k -Nearest Neighbor, and Naïve Bayes, were applied. In this study, the WEKA open-source data mining tool (Bouckaert et al., 2010) were utilized for the implementations of these machine learning techniques.

D. Performance Measures

The performance of the ECG signal quality classification is measured using four statistical measures, i.e., Sensitivity (SEN), Specificity (SPE), Selectivity (SEL), and Accuracy (ACC). These measures are given by:

$$SEN = \frac{TP}{TP + FN} \times 100\%$$

$$SPE = \frac{TN}{TN + FP} \times 100\%$$

$$SEL = \frac{TP}{TP + FP} \times 100\%$$

$$ACC = \frac{TP + TN}{TP + FP + TN + FN} \times 100\%$$

where TP (True Positive) and TN (True Negative) are the number of signal segments accurately predicted as “Low Quality” and “High Quality”, respectively. FP (False Positive) and FN (False Negative) are the number of signal segments inaccurately predicted as “Low Quality” and “High Quality”, respectively.

For avoiding the effects of data unbalancing (Sokolova, 2009), the F_1score is additionally employed to evaluate the performance of the signal quality classification. This measure is a combination of Sensitivity and Selectivity measures, also known as Recall and Precision in text classification evaluation. It is defined as follows:

$$F_1score = 2 \times \frac{SEN \times SEL}{SEN + SEL} \times 100\%$$

IV RESULTS AND DISCUSSION

For evaluating the signal quality classification, a 10-fold cross validation technique (Witten, et al., 2005) was employed. Table 2 illustrates the performance results of signal quality classification using dissimilar window sizes (1 to 10 seconds) and four classification algorithms, i.e., Decision Tree (DT), Multilayer Perceptron (MLP), k -Nearest Neighbor (k -NN), and Naïve Bayes (NB). The overall performance results were between 68.78% and 88.65% for sensitivity, between 96.02% and 98.89% for specificity, between 72.14% and 90.06% for selectivity, and between 93.01% and 96.37% for accuracy.

The DT classifier yielded the highest accuracy of 96.21% using a 7-second window size and the highest sensitivity of 98.89% for 10 seconds. Utilizing an 8-second window size, the top specificity and selectivity of 98.89% and 89.41 were obtained, respectively. For MLP with a 5-second window size, the best accuracy, specificity, and selectivity of 96.37%, 98.73%, and 90.06% were obtained, respectively. The top sensitivity value was 81.58% for a window size of 7 seconds. Using k -NN ($k = 3$) and a 5-second window size, the classifier gained the highest accuracy and sensitivity of 79.68% and 96%, respectively. The top specificity and selectivity of 98.43% and 87.82% were obtained when using a window size of 7 seconds. The NB classifier with 7-second window size provided the highest accuracy, specificity, selectivity of 95.08%, 97.51%, and 81.89%, respectively. For a 5-second window size, NB achieved the maximum sensitivity of 79.41%. The performance results obtained from each algorithm demonstrate that the window size has different effects on the signal quality classification.

Table 2. Performance Comparison of Classification Algorithms Using 10 different Window Sizes

Algorithm	Measure	Window Sizes (Second)									
		1	2	3	4	5	6	7	8	9	10
Decision Tree (DT)	SEN	74.97%	81.36%	78.76%	77.17%	83.96%	79.73%	81.95%	68.78%	86.00%	88.65%
	SPE	98.45%	97.69%	98.57%	97.98%	97.54%	98.15%	98.27%	98.89%	97.00%	97.01%
	SEL	87.12%	83.48%	88.20%	84.32%	83.07%	85.71%	87.20%	89.41%	80.00%	81.19%
	ACC	95.57%	95.63%	96.19%	95.42%	95.83%	95.91%	96.21%	95.27%	95.65%	95.95%
Multilayer Perceptron (MLP)	SEN	74.54%	77.12%	79.77%	77.83%	79.95%	79.07%	81.58%	73.30%	82.00%	79.46%
	SPE	98.69%	98.52%	98.54%	97.86%	98.73%	98.57%	98.16%	98.58%	98.25%	98.11%
	SEL	88.80%	88.24%	88.17%	83.64%	90.06%	88.48%	86.45%	87.57%	86.77%	85.96%
	ACC	95.72%	95.83%	96.29%	95.39%	96.37%	96.19%	96.07%	95.54%	96.26%	95.75%
<i>k</i> -Nearest Neighbor (<i>k</i> -NN)	SEN	72.11%	73.31%	77.26%	75.87%	79.68%	78.07%	78.57%	78.73%	75.00%	77.84%
	SPE	98.35%	98.20%	98.50%	97.74%	98.35%	98.02%	98.43%	97.84%	97.90%	98.04%
	SEL	85.90%	85.43%	87.50%	82.51%	87.39%	84.53%	87.82%	83.25%	83.33%	85.21%
	ACC	95.13%	95.07%	95.95%	95.04%	96.00%	95.59%	95.93%	95.54%	95.10%	95.47%
Naïve Bayes (NB)	SEN	70.11%	72.03%	75.75%	75.65%	79.41%	75.75%	78.20%	76.02%	75.50%	77.84%
	SPE	96.22%	96.03%	96.52%	96.36%	97.00%	96.54%	97.51%	96.97%	96.02%	96.94%
	SEL	72.14%	72.26%	74.75%	74.52%	79.20%	75.25%	81.89%	77.42%	72.60%	78.69%
	ACC	93.01%	93.01%	94.03%	93.81%	94.79%	94.01%	95.08%	94.45%	93.50%	94.51%

Note: SEN = Sensitivity, SPE = Specificity, SEL = Selectivity, ACC = Accuracy

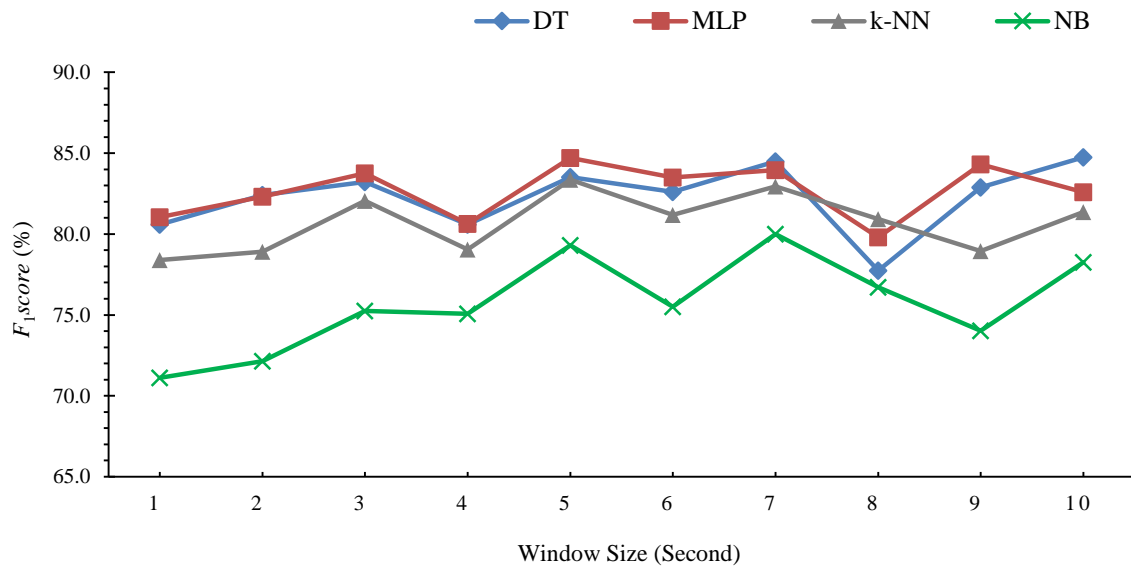

Figure 2. Effects of the Window Size on Signal Quality Classification Performance (F_1 Score)

performance. Using window sizes of 5 and 7 seconds, the good classification results are mostly achieved (e.g., MLP, *k*-NN, and NB). Conversely, for all algorithms, the low performance results are always obtained for window sizes lower than 5 seconds.

However, in order to avoid data unbalancing impacts, the F_1 score measure was additionally used for evaluating the performance of each classification model. Figure 2 illustrates the F_1 score results of signal quality classification using four machine learning algorithms and different window sizes. The overall results were between 71.11% and 84.75%. For MLP and *k*-NN (*k* = 3) using a 5-second window size, the

maximum performance results were obtained, which were 84.70% and 83.36, respectively. Using DT, the best and second-best results, 84.75% and 84.50%, were achieved using window sizes of 10 and 7 seconds, respectively. NB showed the top performance result with an F_1 score equal to 80% for 7 seconds.

These obtained results show that the most performance of classifying ECG signal quality levels was increased when the window size was increased until 7 seconds. For example, the NB provided the minimum results (71.11%) for 1 second. It yielded the second-best and best results (79.31% and 80%) using

window sizes of 5 and 7 seconds, respectively. Although some algorithms, DT and MLP, achieved the good performance results for a couple of higher window sizes (e.g., 9 and 10 seconds), such results were not much different from the experimental results using the 5-second and 7-second window sizes. Moreover, utilizing the window sizes between 1 to 4 seconds and an 8-second window size should not be suggested for ECG signal quality classification.

V CONCLUSION

A comprehensive study on the effects of window size on ECG signal quality classification has been proposed. In this study, several machine-learning-based methods techniques and signal-amplitude-based features, which were widely employed in previous works, were used for constructing signal quality classification models. For investigating the window size effects, 10 different window sizes, ranging from 1 to 10 seconds, were considered in the experiments. As demonstrated by the evaluation results, the suitable window sizes were 5 and 7 seconds and the use of sizes between 1 to 4 seconds were not suggested for classifying the quality of ECG signals.

ACKNOWLEDGMENT

This work was supported by the Research Institute of Rangsit University and the Thailand Research Fund (TRF), under Royal Golden Jubilee Ph.D. Program.

REFERENCES

- AAMI. (2002). Cardiac monitors, heart rate meters, and alarms, american national standard (Revision of ANSI/AAMI EC13:2002). Association for the Advancement of Medical Instrumentation, Arlington, VA, Technical Report.
- Aydin, N., & Markus, H.S. (2000). Optimization of processing parameters for the analysis and detection of embolic signals. *European Journal of Ultrasound*, 12(1), 69-79.
- Banos, O., Galvez, J.-M., Damas, M., Pomares, H., & Rojas, I. (2014). Window size impact in human activity recognition. *Sensors*, 14(4), 6474-6499.
- Barill, T. P. (2005). *The six second ECG: A practical guidebook to basic ECG interpretation*. Palm Springs, California, USA: SkillStat Learning Inc.
- Bouckaert, R. R., Frank, E., Hall, M. A., Holmes, G., Pfahringer, B., Reutemann, P., & Witten, I. H. (2010). WEKA-Experiences with a Java Open-Source Project. *J. Mach. Learn. Res.*, 11, 2533-2541.
- Catalano, J. T. (1993). *Guide to ECG analysis*: J. B. Lippincott.
- Chudacek, V., Zach, L., Kuzilek, J., Spilka, J., & Lhotska, L. (2011). Simple scoring system for ECG quality assessment on android platform. *Proceedings of the Computing in Cardiology Conference*, Hangzhou, China.
- Clifford, G. D., Azuaje, F., & McSharry, P. (2006). *ECG statistics, noise, artifacts, and missing data Advanced methods and tools for ECG data analysis* (pp. 55-99). London: Artech House.
- Clifford, G. D., Behar, J., Li, Q., & Rezek, I. (2012). Signal quality indices and data fusion for determining clinical acceptability of electrocardiograms. *Physiol. Meas.*, 33(9), 1419-1433.
- Hampton, J. R. (2008). *150 ECG problems*: Elsevier.
- Hayn, D., Jammerbund, B., & Schreier, G. (2012). QRS detection based ECG quality assessment. *Physiol. Meas.*, 33(9), 1449-1461.
- Joachim, B., Julien, Q., Qiao, L., & Gari, D. C. (2013). ECG Signal Quality During Arrhythmia and Its Application to False Alarm Reduction. *IEEE Trans. Biomed. Eng.*, 60(6), 1660-1666.
- Johannesen, L., & Galeotti, L. (2012). Automatic ECG quality scoring methodology: mimicking human annotators. *Physiol. Meas.*, 33(9), 1479-1489.
- Kuzilek, J., Huptych, M., Chudacek, V., Spilka, J., & Lhotska, L. (2011). Data driven approach to ECG signal quality assessment using multistep SVM classification. *Proceedings of the Computing in Cardiology Conference*, Hangzhou, China.
- Li, Q., & Rajagopalan, C. C., G. (2014). A machine learning approach to multi-level ECG signal quality classification. *Computer Methods and Programs in Biomedicine*, 117(3), 435-447.
- Norman, A. E. (1992). *12 lead ECG interpretation a self-teaching manual*: McGRAW-HILL.
- Schmid, F., Goepfert, M. S., & Reuter, D. A. (2013). Patient monitoring alarms in the ICU and in the operating room. *Crit. Care.*, 17(2), 216-222.
- Schumm, J., Arnrich, B., & Troster, G. (2012). ECG monitoring in an airplane seat: appraising the signal quality. *IEEE Pervasive Comput.*, 11(4), 28-34.
- Silva, I., Moody, G. B., & Celi, L. (2011). Improving the quality of ECGs collected using mobile phones : the PhysioNet/Computing in cardiology challenge 2011. *Proceedings of the Computing in Cardiology Conference*, Hangzhou, China.
- Sokolova, M., & Lapalma, G. (2009). A systematic analysis of performance measures for classification tasks. *Inf. Process Manag.*, 45(4), 427-437.
- Tanantong, T., Nantajeewarawat, E., & Thiemjarus, S. (2015). False alarm reduction in BSN-Based cardiac monitoring using signal quality and activity type information. *Sensors*, 15(2), 3952-3974.
- Thongpanja, S., Phinyomark, A., Quaine, F., Laurillau, Y., Wongkittisuksa, B., Limsakul, C., & Phukpattaranont, P. (2013). Effects of window size and contraction types on the stationarity of biceps brachii muscle EMG signals. *Proceedings of the 7th International Convention on Rehabilitation Engineering and Assistive Technology*, Gyeonggi, South Korea.
- Witten, I. H., Frank, E., & Hall, M. A. (2005). *Data Mining: Practical machine learning tools and techniques*, 3rd Edition. Burlington: Morgan Kaufmann/Elsevier.
- Yang, G. Z. (2006). *Body sensor networks*. London: Springer-Verlag.
- Zaunseder, S., Huhle, R., & Malberg, H. (2011). CinC challenge-assessing the usability of ECG by ensemble decision trees. *Proceedings of the Computing in Cardiology Conference*, Hangzhou, China.

Antecedents of Cloud ERP Adoption in Manufacturing Industry: Nigerian SMEs Context

Usman Musa Zakari Usman, Mohammad Nazir Ahmad, and Nor Hidayati Zakaria

Universiti Teknologi Malaysia, Malaysia, usmanmzusman@gmail.com, {mnazir; hidayati} @utm.my

ABSTRACT

Cloud ERP systems are continuously replacing the implementation of traditional ERP systems within the enterprise industry, the cloud ERP system's ability to exploit internet's continuity. The increased reliability of cloud infrastructures has made it economically feasible to deliver ERP systems over the internet, at less risk than that involved with traditional ERP, allowing for the transfer of maintenance and support to the vendor. Cloud ERP system also enables small and medium-sized budget organizations to access incredibly robust technology at an affordable cost, and at a low cost of ownership, with quick deployment and a fast return of investment. Manufacturing company today are faced with challenge as the world is moving faster and more connected than before, nature of world economy, growth in consumer technology, and rapidly changing and sometimes, unpredictable consumer purchasing behaviors, all brings both opportunity and risk, as a result manufacturer need to invest in the next generation of industrial automation solution. Factors that are significant to influence adoption cloud ERP in SMEs are still unclear, mainly in the context of developing countries and Nigeria in particular. Therefore, this research paper discusses various potential factors from relevant literature that would influence manufacturing SMEs to adopt cloud ERP system.

Keywords: Cloud, Enterprise Resource Planning (ERP), SMEs

I. INTRODUCTION

Enterprise Resource Planning systems (ERP Systems) can effectively support the functionalities and business performance of small and medium enterprises (SMEs), the SMEs can also be benefit in terms of managing organizational information (Prashant Gupta and A. Seethraman, 2013). Cloud ERP systems are used in a format where users rent the software instead purchasing the software. (Ivanov 2012). By renting the software, organizations can minimize implementation and maintenance costs, and can also gain access to an ERP system that allow SMEs to focus more on their organizational missions without needing to devote substantial resources to

maintaining ERP software (Salim Siti Aisyah. 2013). There are few resistances because of which cloud ERP is not yet widely accepted by the SMEs in some developing countries. Due to very little research has been conducted on cloud ERP adoption in the past in Africa with most studies having been carried out in Europe (Equey & Fragniere 2007, Olhager & Selldin 2003), Asia (Upadhyay & Dan 2009:3), Australia (Zhou, Xing & Nagalingam 2010:306). However, the adoption rate of cloud ERP in Nigeria is still in the beginning stage with not many adoptions within the SMEs. This study focuses on the adoption of cloud ERP among Nigerian SMEs in manufacturing industry. This is because obtaining such opportunities rests largely upon the ability of SMEs to engage in the regional and global economic business networks which in turn demand provision of a prerequisite level of access to and use technology. The cloud ERP evolution had made it easy and lower cost for SMEs to afford for their business process and managing organizational information. Accordingly, the willingness to adopt cloud ERP systems among SMEs in Nigeria remains low.

Therefore, this research seeks to address the gap by highlighting some factors that influence the adoption of Cloud ERP systems by manufacturing SMEs in Nigeria. The current gap in the literature has led us to the following research question: what factors influence cloud ERP adoption in manufacture industry among SMEs in Nigeria? To accomplish the understanding of these factors, the researcher developed a model of cloud ERP adoption using factors from previous findings.

The research paper is structured as follows: first, we provide an overview of ERP and cloud ERP systems based on the extant literature. Next we analyses the adoption model of cloud ERP through five themes, which includes; external support, organizational support, technology applicability, external pressure and internal pressure. The paper concludes with suggested future study direction and research implications regarding academic and practical work.

II. THEORETICAL BACKGROUND AND RESEARCH MODEL

A number of researches have been done to draw systematic study of cloud ERP adoption. Pareek

(2014) have tried to compare all aspects of traditional ERP systems with cloud base ERP architectures. He found that the cost of the cloud ERP implementation is lower than that of traditional implementation and flexibility of cloud ensures competitive advantages to a particular company. Weng and Huang (2014) have also identified different benefits and challenges of cloud ERP. The study of Duan et al. (2013) is almost similar with the study of Weng and Hung, which identify and classify the benefits and drawbacks of cloud-based versus traditional ERP systems. They explored that cloud ERP systems provide mature system functionality and abilities of greater customization and integration. Navaneethakrishnan (2013) revealed that Cloud ERP system provides solutions to all the difficulties encountered by convention ERP systems. It provides flexibility and improves overall efficiency of the organization. Sahin (2013) identified potential security issues arising from deploying of the cloud ERP systems from provider perspectives in order to contribute current knowledge in cloud ERP implementation in Sweden. Singh and Nagpal (2014) analyzed the issues concerning with the execution of ERP in cloud computing. They mentioned that lot of the researches focused on one topic and few of them have taken both as a study. They covered diverse aspects of both ERP and Cloud Computing and after studying their major benefits and challenges they suggested few recommendations. Cloud ERP is a mix of standard ERP services along with cloud flexibility. Sharma and Keswani (2013) draws a framework for selecting non-core business process from preferred ERP service partners and also recommends which ERP services outsourced first over the cloud, and the security issues related to data or information moved out from company premises to the cloud eco-system. The goal of Al-Johani and Youssef (2013) study is to merge ERP and cloud computing benefits together to reduce the factor of expenditure cost and implementation delays through a proposed framework. Their framework for “Cloud based ERP systems” follows multi-instance based cloud infrastructure that initiates different ERP instances for different industries. Zhang and Wang (2013) proposed an engineering approach and methodology of constructing the knowledge driving, cloud-based ERP service system for Small and Medium Sized Enterprises (SMEs). Salim (2013) have identified 27 transition factors contributing to the adoption of cloud ERP based on a content analysis of one hundred studies. He classified transition factors as “necessary” or “sufficient”; where “necessary” transition factors need to exist in order for the firm to move to the next stage, while “sufficient” means assisting in the movement. From the literature, it is observed that most of the research has focused more on benefits and challenges of cloud ERP; framework developed from precious authors for

cloud ERP, and factors toward cloud ERP adoption from provider’s perspectives. Only few numbers of studies have focused on the organization or end users perspective that plays a significant role in successful adoption of cloud ERP. This study attempt to fill the gap, by analyzing the adoption and acceptance issues of cloud ERP based on user’s perspectives.

Based on the above section discussion, factors such as cost, security, and privacy have a considerable effect on cloud ERP adoption. Therefore, in any effort to conduct study into matter of cloud ERP adoption, three constructs such as data security, cost and privacy is imperative to add into the TAM-DTM model. TAM modified the version and TAM-DTM has widely used in previous studies considering adoption of new technologies (López-Nicolás, et al., 2008; Wu, Lan, & Lee, 2011). Hence, based on the discussions presented in section above, these three constructs and other factors that are prior in most of the studies in adoption were examined in TAM model. Consequently, this research suggests TAM model that combine related theories with the imperative construct such as security, privacy and cost in order to gain more insights into the adoption of cloud ERP.

Based on Figure 1, there are factors such as cost and security that are important factors to be considering for adoption of cloud ERP based on prior studies in Nigeria. Hence, these constructs selected according to their number of appearance in different studies, to add TAM-DTM model. They have considerable impact on cloud ERP adoption in terms of users’ perspectives



Figure 1. Research Model.

Organizational factors: The organizational factors have an effective impact on organization intention to adopt the new information systems technology; this study will look into dimension that represents different organizational conditions, which include variables such as support from top management, adequate resources, and the benefits of adoption. For the management's support, it depends on how well the executives understand the whole nature and functions of cloud-based ERP system and then the fully support its adoption in the organization.

Chang et al. (2006) conducted a study, which found that top management's support would affect the adoption of new information systems. Cloud technology is usually a huge project and it's undertaking for organization, a guarantee support from the executives is usually critical for creating a support and providing adequate resources for adopting the new technology. As the technology is increasing by its rate of complicity, the executive management provide vision and commitment to ensure sustainable environment for innovation.

The top management decision to adopt cloud ERP system is very crucial, as the implementation of the system will result changes such as resource integration and reengineering of information within the organization. By regarding this discussion, this dimension is consisting of four variables, which include: top management support, performance the implementation cost, and benefits of implementing the system.

H1: There will be a positively significant relationship between benefits and the adoption of cloud ERP adoption.

H2: There will be a positively significant relationship between cost implementation and the adoption of cloud ERP adoption.

H3: There will be a positively significant relationship between performance and the adoption of cloud ERP adoption.

H4: there will be a positively significant relationship between the top management support and the adoption of cloud ERP

Technological Factors; Observing the technology applicability which includes: the data security, compatibility, complexity and implementing cost of technology. Based on previous researchers, the complexity and compatibility of information system will positively have impact towards the adoption of specific information technology within an organization. As result, the nature of cloud ERP technology, securing data and information privacy are most crucial and concerning issue related to ERP

adoption. This makes it necessary for the development of a secure environment for cloud based ERP system data integration and sharing information flowing within system is critical, for this reason data security become one of the key variables in technology dimension. Research shows that, the complexity factors of new technology, usually has a negative effect, as the complexity of an innovation can be a barrier to the implementation of new technology, most organizations are lacking the confident on cloud system, because it appears unfamiliar to embarrass, this will make their decision of accepting and implanting the new system take a long time decision-process. As a result, the complexity of any new system is a key criterion during decision making to adopt ERP system. The systems most show a potential functionality of handling complex tasks and other organizational information. Another critical factor that the organization need give important consideration when making a decision to adopt cloud ERP system is the migration from the traditional system to the new emerging cloud system. This is very important factor, as no organization will accept migrating to new system with considering the privacy and security with the existing information that keep the organization running.

New technology is only adopted by any organization when it is compatible with the with the work application system of the specific organization, if technology appear to be incompatible with current application system of an organization, it's likely the organization will not adopt the new technology, because the compatibility factors it determined by degree in which innovation fit with the potential adopter's existing values, previous practices and current needs. Another key factor which within the technical dimension is the level of system compatibility, if the cloud technology is well compatible with the current systems or the application of organizations, therefore the adoption will be positively more impact and feasible. As a result of varied and extensive nature of costs, the companies can look for an expensive with this kind of project to be sizable to fit their business process, with this reason; costs are a critical factor for the adoption decision.

H5: There will be a positively significant relationship between Data Security and the adoption of cloud ERP adoption.

H6: There will be a negatively significant relationship between relatively advantage and the adoption of cloud ERP adoption.

H7: There will be a positively significant relationship between compatibility and the adoption of cloud ERP adoption.

H8: The adoption of Cloud ERP has had a positively-significant relationship with the scalability

Local Factors: From the literature review in adopting into innovation, local factors are highlighted as important key driver of adoption (e.g., Grover and Teng 1994, L. et al. 1995; Premkumar and Roberts 1999) small and medium enterprises are normally under pressure for not only competitiveness, but there are pressure from other sources. Although when comparing other related pressure, technology adoption is influence more from competitors pressure, competitive pressure can be refer to the level of pressure any organization is placed under by competitors within it industry. The strategical way SMEs take which normally rely on trading partnership such as user, can bring extensive consideration for adoption of cloud ERP (Pan and Jang 2008). Based on several studies presented, the pressure exerted by large users, onto smaller training partners can result in the need for adoption of technology (Premkumar 2003)

A study by Chan and Ngai (2009) showed that, the majority of companies were curiously like their competitors are pushing them with pressure, this curiosity leads them to adopt the new technology. The adoption decision making process was also validated by the used of an influential theory. In which trading organization's partner fully influence one perspective organization (Chan and Ngai 2009), when they are also pressured by the suppliers (Caldera and ward 2007) SMEs are also pressured to employ standard systems, that are used as their competitors for business partnership continuity.

As a result, affordability that makes organizations (SMEs) to adopt the new cloud system customized cloud ERP system can maintain the existing relationship with the traders (Khoumbati et al. 2006) the enforcement of any new polity can have an influence on technology innovation (Teo and Ranganathan 2010)

Another external pressure may come from the government, according previous researcher (Mckeon, 2012) the US government deployed cloud social network by the used of salesforce.com site, this affect several US department and other governmental agencies within the country, this shows that organizations can also receive pressure from the government that will lead to adopt new technology.

Internal pressure is often from the gap in an organization's performance towards its product and

service, this lead the organization to adopt with new technology system to be competent in its performance, the gap can be as a result of uncertainty of company's target market, where an organization needs to innovate to new technology to be competitive among. Although mobilizing and leveraging assets that are owned by other enterprises can be the means to grow SMEs (Hagel 2002). As a result, implementing new technology is needed to seal the gap, upgrading and maintaining technology infrastructure.

Based on the several works of different researchers (e.g. Kamal, 2006, Moon and Norris 2005) agreed that, support from external parties within the locality is an important factor that influence adoption, Factors that cannot be control or change by organization are called local factors (Quaddus and Hofmeyer 2007). These factors help to update the organization with an effective new technology to be adopted to survive in this dynamic world of technology. As opposed to just pressure to adopt the ERP cloud. Technical diffusion agencies, innovation manufacturers and innovation vendors all have roles to play in dispersing new technology products or services (Von Hippel 2007). Support from industry associations can be in the form of advice and experience from another industry association (Kole 1983), in providing a better understanding of business environments that they are working on together. Another example of support that could influence the adoption of new technology is through a subsidy. Tax exemption can be a meaningful incentive for SMEs, as it can help them to manage their financial scarcity.

H9: The adoption of Cloud ERP has had a positively-significant relationship with the government subsidy

H10: The organization performance has a positively-significant relationship with users/suppliers.

III. CURRENT RESEARCH DIRECTION

This study will explore the list of most influential (priority) factors that lead to cloud ERP adoption within SMEs in manufacturing industry at the final decision making and discusses the preliminary findings of research attempting to identify and categorized each of the factors extracted from the literature. Considering the factors identified could be from internalize (organizational factors) or externalize (external factors), the goal is to derive a comprehensive, robust, valid and applicable model to cloud ERP adoption targeting small-medium enterprises (SMEs) within manufacturing industry in Nigeria.

This research analysis activity will provide useful insights into the relationship between these factors, findings or result from this study are solely based on primary and secondary data which are from

questionnaires and past literatures respectively, therefore the most motivational factors are limited to range that has been identified in the literatures.

The study will not only provide implication to academic research by providing potential set of cloud ERP adoption factors but will also provide insight ideas on this research topic area. This study will also provide implications for practice as cloud ERP systems are getting prominent as predicted by year 2015, low-cost cloud services will cannibalize up to 15% of top outsourcing players' revenue (Plummer et al. 2011). This study will provide significant implication to vendors, consultants and ERP clients in several ways. The ERP vendors are an example of beneficiary of this study.

This study will also be a pilot study to understand factors that could be more emphasize towards their client in persuading to adopt cloud ERP product. From client point of view, this study could at least provide a general picture on what they can expect from ERP vendors before making decision whether to adopt or not cloud ERP.

IV. RESEARCH CONTRIBUTION

This research paper presents an important contribution to enterprise information system domain as a whole. The author presents a discussion of relevant factors that influence the adoption of cloud-based ERP system; the focus of the paper is based on the factors and their impact to influence the organization to adopt the new technology systems within the competitive industrial. The main result and contribution of this paper is to target both the researchers and practitioners by creating a room for discussion and future investigation within the cloud ERP area. The research paper also further to discuss the concept and operationalizes the factors utilized in cloud ERP adoption. The result contribution of this paper can enhance the general perception of cloud-based ERP system, which will cloud lead to comprehensive change of cloud ERP systems that cloud result in accelerating its diffusion. Certainly, there may be some aspect that the paper couldn't be able to look into, and even additional factors that were not giving consideration with this paper. Although, the factors discussed in this research paper are factors that covers most important aspect within the adoption of cloud ERP with the aim of bridging the gap that lie within current research practice.

V. CONCLUSION AND FUTURE WORK

Finding from this research present the most influential factors towards the adoption at the final stage of decision making, the research model is drive from the TAM-DTM model, as discussed earlier, while some existing research has examined the benefits and challenges of cloud adoption, this papers explores a list

of factors that can lead to cloud ERP adoption in SMEs. It also discusses the preliminary findings of research that attempts to identify and categorize each of the extracted factors. Considering that the factors identified could be internalized (organizational factors) or externalized (external factors), the goals is to establish a tough and valid approach to cloud ERP adoption, targeting small-medium enterprises (SMEs) within Nigeria. The research approach for this paper employed two interrelated phases. The first phase was exploratory, with the objective being a conceptual model of cloud ERP adoption in SMEs, findings or results from this study are solely based on secondary data, as obtained from past literature. Therefore, motivational factors are limited to the ranges that have been identified in literature. The second stage involved a series of focus groups planned in order to further improve the findings that have gathered from this study. The final adoption factors will then be tested using a quantitative survey. This study not only has important implications for academic research, by providing a potential set of cloud ERP adoption factors, but also serves as an insight into ideas within this research topic area. The study also has implications on the practical side, as cloud ERP systems are gaining prominence. It is predicted that in upcoming years, low-cost cloud services will cannibalize up to 15 per cent of top outsourcing player's revenue (Plummer et al. 2011). This study has significant implications for vendors, consultants and ERP clients in several ways. For ERP vendors, this study serves as a pilot study for understanding the factors that could encourage their adoption of the cloud ERP product. From the client's point of view, this study can provide a general picture of what they can expect from ERP vendors, before making a decision about whether to adopt cloud ERP or not.

REFERENCES

- Caldeira, M.M., and Ward, J.M. 2003. "Using Resource-Based Theory to Interpret the Successful Adoption and Use of Information Systems and Technology in Manufacturing Small and Medium-Sized Enterprises," *European Journal of Information Systems* (12:2), pp. 127-141.
- Kamal, M.M. 2006. "IT Innovation Adoption in the Government Sector: Identifying the Critical Success Factors," *Journal of Enterprise Information Management* (19:2), pp. 192-222.
- Quaddus, M., and Hofmeyer, G. 2007. "An Investigation into the Factors Influencing the Adoption of B2B Trading Exchanges in Small Businesses," *European Journal of Information Systems* (16:3), pp. 202-215.
- Von Hippel, E. 2007. "Horizontal Innovation Networks—By and For Users," *Industrial and Corporate Change* (16:2), pp. 293-315.
- Chang, S.E., and Ho, C.B. 2006. "Organizational Factors to the Effectiveness of Implementing Information Security Management," *Industrial Management & Data Systems* (106:3), pp. 345-361.
- Grover, V., and Teng, T.C. 1994. "Facilitating the Implementation of Customer-based Inter-organizational systems: An Empirical Analysis of Innovation and Support Factors," *Information Systems Journal* (4:1), pp. 61-89.
- Prenkumar, G. 2003. "A Meta-Analysis of Research on Information Technology Implementation in Small Business," *Journal of Organizational Computing and Electronic Commerce* (13:2), pp. 91-121.

- Chan, S.C.H., and Ngai, E.W.T. 2007. "A Qualitative Study of Information Technology Adoption: how Ten Organizations Adopted Web-based Training," *Information Systems Journal* (17:3), pp. 289-315.
- Caldeira, M.M., and Ward, J.M. 2002. "Understanding the Successful Adoption and Use of IS/IT in SMEs: An Explanation from Portuguese Manufacturing Industries," *Information Systems Journal* (12:2), pp. 121-152.
- Khoumbati, K., Themistocleous, M., and Irani, Z. 2006. "Evaluating the Adoption of Enterprise Application Integration in Health-Care Organizations," *Journal of Management Information Systems* (22:4), pp. 69-108.
- Teo, T.S.H., and Ranganathan, C. 2004. "Adopters and non-adopters of business-to-business electronic commerce in Singapore," *Information & Management* (42:1), pp. 89-102.
- Gargeya, V.B., and Brady, C. 2005. "Success and Failure Factors of Adopting SAP in ERP System Implementation," *Business Process Management Journal* (11:5), pp. 501-516.
- Plummer, D.C., Middleton, P., Cain, M.W., Clark, W., Rold, C.D., Dominy, M., Feiman, J., Gartenberg, M., Lopez, J., Notardonato, S., Pescatore, J., Prentice, B., Prentice, S., and Tay, G. 2011. "Summary Report for Gartner's Top Predictions for IT Organizations and Users, 2012 and Beyond: Control Slips Away." Gartner, Inc.
- Salim Siti Aisyah. (2013) Cloud Erp Adoption-A Process View Approach. Information Systems School, Queensland University of Technology, Australia
- Lopez-Nicolas, C., Molina-Castillo, F.J., & Bouwman, H. (2008). An assessment of advanced mobile service acceptance: Contributions from Tam and diffusion theory model. *Journal of Information & Management*.
- Wu, Lan & Lee (2011). Exploring decisive factors affecting an organizations SaaS adoption: A case study. *International journal of information Management*.
- Arnesen, S. (2013). Is Cloud Erp Solution Right For You. *Strategic Finance*, 95(2), 45-50
- Michel, S. (2004). Capture More Value. *Harvard Business Review*, (October 2014). Ostling, F., & Fredriksson, J. (2012). Adoption factors for cloud based enterprise resource
- Gargeya, V.B., and Brady, C. 2010. "Success and Failure Factors of adopting SAP in ERP system implementation," *Business Process Management Journal* (11:5), pp. 501-516.
- Grandon, E.E., and Pearson, J.M. 2004. "Electronic Commerce Adoption: An Empirical study of small and Medium US Businesses," *Information & Management* (42:1), pp. 197-216.
- Walterbusch, M., Martens, B., & Teuteberg, F. (2013). Evaluating cloud computing services from a total a cost of ownership perspective. *Management Research Review*, 36(6), 613-638. Doi: 10.1108/01409171311325769
- Hagel, J. 2002. *Out of the box: Strategies for Achieving Profit Today and Growth Tomorrow through Web Services*. Harvard Business Press.
- Herstatt, C., and Lettl, C. 2004. "Management of Technology push Development Projects," *International Journal of Technology Management* (27:2), pp. 155-175.
- Hovav, A., Patnayakuni, R., and Schuff, D. 2004. "A Model of Internal Standards Adoption: The Case of IPv6," *Information Systems Journal* (14:3), pp. 265-294.
- Hsieh, H.F., and Shannon, S.E. 2005. "Three Approaches to Qualitative Content Analysis," *Qualitative Health Research* (15:9), pp. 1277-1288.
- Hsu, C., Lee, J.-N., and Straub, D.W. 2012. "Organizational Influence on Information Systems Security Innovations," *Information Systems Research* (23:1), pp. 1-22.
- Huang, R., Zmud, R.W., and Price, R.L. 2010. "Influencing the Effectiveness of IT Governance Practices through Steering Committees and Communication Policies," *European Journal of Information System* (19:3), pp. 288-302.
- Ivanov, I.I. 2012. "Cloud Computing in Education: The Intersection of Challenges and Opportunities," *Web Information Systems and Technologies* (101:1), pp. 3-16.
- Bunker, D., Kautz, K.-H., Luu, A., and Nguyen, T. 2007. "Role of Value Compatibility in IT Adoption," *Journal of Information Technology* (22:1), pp. 69-78.
- Bunker, D., Kautz, K., and Anhtuan, A. 2008. "An Exploration of Information Systems Adoption: Tools and Skills as Cultural Artefacts-The Case of a Management Information System," *Journal of Information Technology* (23:2), pp. 71-78.
- Buonanno, G., Faverio, P., Pigni, F., Ravarini, A., Sciuto, D., and Tagliavini, M. 2005. "Factors Affecting ERP System Adoption: A Comparative Analysis between SME's and Large Companies," *Journal of Enterprise Information Management* (18:4), pp. 384-426.

Moderating Effect of Personal Characteristics on Telecentre Adoption for Value Creation in Malaysia

Zulkhairi Md Dahalin, Nor Iadah Yusop and Zahurin Mat Aji

Universiti Utara Malaysia, Malaysia, {zu, noriadah, zahurin}@uum.edu.my

ABSTRACT

This paper examines the influence of personal characteristics of community within the vicinity of rural telecentres on the relationship between adoption of ICT and value creation. The aim was to identify characteristics of members of the community that have positive or negative influence on the adoption of the telecentre in order to gain socio-economic impact. A survey was conducted among the community within the vicinity of the telecentres where data was gathered on respondents' demography, their perceptions on availability of ICT facilities at the telecentre, and the benefits gained from using the ICT facilities. The Diffusion of Innovation theory was used to guide the research and moderating analysis was used as data analysis. Results show that age, gender, marital status and PC ownership as significant moderators that affect the relationship between telecentre adoption and value creation.

Keywords: Bridging Digital Divide, socio-economic, Diffusion of Innovation.

I. INTRODUCTION

Telecentre project is one of the Information and Communication Technology (ICT) initiatives that has been proven to be successful in bridging digital divide (BDD) amongst the underserved community who mainly reside in rural areas (Nor Iadah et al., 2015; Zulkhairi et al., 2015). Bridging digital divide involves efforts in reducing the gap of disparities in adopting ICT among members of the community. It is seen as giving values towards the benefit of development generated through ICT rather than merely having physical access to ICT (EPU, 2007). The National Strategic Framework for Bridging Digital Divide (NSF-BDD) (Yogeesvaran, 2007) is a national policy established by the Malaysian government as a guide towards BDD. The framework sets socio-economic development as being the indicator to mark the success of ICT initiatives for the community which is termed as value-creation. This includes any action related to the use of telecentre that increases the worth of goods, services or even businesses (Zulkhairi et al., 2015). To achieve the value-creation state, the served community has to partake technology as part of their daily routines, and this is referred to as "adoption".

Telecentre is not just a public space where people can access ICTs facilities and services but also has become a gathering hub where local community can get together to access and produce relevant and useful information (Bailey, 2009; Gomez & Gould, 2010). Such centre can also be considered as a centre of developing human resource in IT as well as to the overall community development. This is evidenced by Zulkhairi et al. (2015) who indicated that the establishment of the centres have given opportunities for the rural communities to access information, obtain jobs, improve soft and technical skills, provide study opportunities, and generate income. These are among the values that the community attained by adopting telecentre.

Obtaining access to ICTs and using them actively has been linked to the advantages of demographic and socio-economic characteristics, namely; income, education, geographic location (urban-rural), skills, awareness, political and cultural perspectives. In this context, it is equally important to ensure that all clusters of society in Malaysia have equitable access to ICT and have the adequate capacity to improve their socio-economic status as a result of the digital access. The level of ICT uptake by the members of the community as part of their daily routine depends on who they are. Mohamad Amir et al. (2012), Johansson Hedberg (2011) and Mukerji (2009) indicated that the access and use of telecentre were related to the socio-economic status of the community, which includes age, gender, education, and occupation. The types of occupation provide indications of individuals' income status.

Many studies reported that youths tend to participate more actively compared to the older generations (Zahurin, 2014; Abu Samah et al., 2013; Attwood et al., 2013; Gomez & Camacho, 2013; Zulkhairi et al., 2012; Mohamad Amir et al., 2012; Mohammad Badsar et al., 2011; Bailey & Ngwenyama, 2010). The youngsters were frequent users of telecentre as they were recognized to be "naturally close" to technology (Gomez & Camacho, 2013). It was also found that they used telecentres mainly for entertainment and social networking (Zulkhairi et al., 2012). Apart from that, other purposes include to search for education-related information, do their school homework or college assignments (Gomez &

Camacho, 2013; Mbatha, 2015). On the other hand, most of the older adults use technology to update and obtain information, and to communicate with relatives and friends (Frias et al., 2011). Hence, economic benefits from such usage were not that obvious, but they did gained social-related benefits from its usages.

With regards to gender, some studies indicated that there are more males than females (Johansson Hedberg, 2011; Kumar & Best, 2006), some said that females dominate (Mohammad Badsar et al., 2011; Abu Samah et al., 2013) whilst others showed not much difference between the number of male and female users (Gomez & Camacho, 2013). Low education and literacy level were identified as barriers for women access to telecentre (Bailey & Ngwenyama, 2009; Mohammad Badsar et al., 2011; Terry & Gomez, 2011;). However, Lesame (2008) and Hansson et al. (2010) indicated that upon receiving appropriate ICT trainings, women can be empowered to maximize the use and benefits of technology, eventually enable them to compete successfully in the global information economy, with their male counterparts, and play a leadership role in its development. Ray and Prasad (2014) supported these by indicating that telecentre appears to be more women friendly as education-driven activities were found to be more attractive to women.

Pertaining to users' income status and education, Zulkhairi et al. (2009) study showed that majority of the telecentres' users were mainly those from low to middle income, and with a high school or college education. This was also supported by Mohammad Badsar et al. (2011), and Gomez and Camacho (2013). Among the reasons for such situation is that telecentres are mainly situated in the rural or suburban areas as they are established to serve those that could not afford to have ICT facilities at home (Gomez, (2014); Prado & Janbek, 2012; Kyobe, 2011; Walsham, 2010). It was also known that people in the rural areas are less educated as compared to their counterparts in the urban area (Gomez, (2014); Rajapakse, 2012; Johansson Hedberg, 2011).

Figure 1 depicts the potential effects of the various elements of personal characteristics of telecentre users on the relationship between adoption of ICT facilities at the telecentre and value that can be created from using the telecentre.

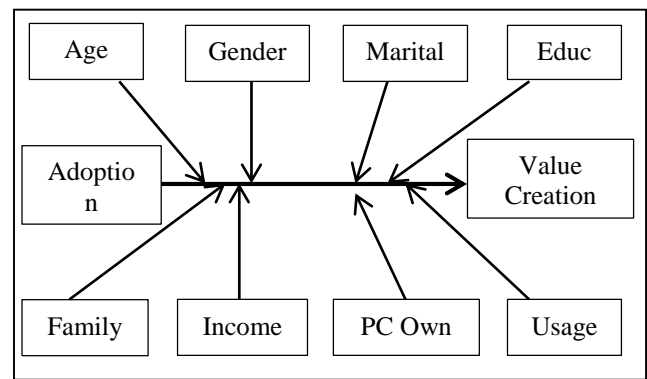

Figure 1. Conceptual model of Telecentre Value Creation with Personal Characteristics as moderators

Based on the literature review, these elements were formulated as eight hypotheses as potential moderators to study the effect of adoption on value creation.

II. METHODS

A survey was conducted among members of telecentre communities in the northern region of Peninsular Malaysia, covering the states of Perlis, Kedah and Penang. A total of 430 questionnaires were distributed to 19 telecentres with 392 returns. Eight questionnaires were discarded due to missing values leaving the remainder of 384 as useful data.

Reliability tests were calculated to check for internal consistency of responses. The results show that values of the Cronbach's alpha range from 0.892 to 0.953 which are above the minimum value of 0.60 as suggested by Hair et al. (2006). This indicates that the responses were reliable with acceptable internal consistency.

The sample used for data analysis was based on the 384 respondents from rural communities in the northern region. Following Rogers' Diffusion of Innovation Theory (Rogers, 2003), the sample data captured respondents' demography, their perception on the adoption of the telecentre in terms of relative advantage, compatibility, complexity, trialability and observation, and their perception on the adoption of ICT facilities at the telecentre. Table 1 depicts the summary of selected variables of interest in this study.

Table 1. Summary of selected variables

Variable	Scale	Value	%
Age Category	Dichotomous	0 (Young)	255 66.4
		1 (Old)	129 33.6
Gender	Dichotomous	0 (Female)	198 51.6
		1 (Male)	186 48.4
Marital Status	Dichotomous	0 (Not Married)	213 55.8
		1 (Married)	169 44.2
Educ	Dichotomous	0 (Not Educated)	303 78.9
		1 (Educated)	81 21.1
Family Size	Dichotomous	0 (Small-Medium)	190 50.9
		1 (Large)	183 49.1
Income	Dicho-	0 (Hardcore/Poor)	301 90.9

Level	tomous	1 (Medium-Rich)	30	9.1
PC Own	Dichotomous	0 (No)	213	56.2
		1 (Yes)	166	43.8
Usage Exp	Dichotomous	0 (Never/Seldom)	137	36.9
		1 (Frequent)	234	63.1
Adoption	Continuous	Min.	1.38	
		Mean	3.99	
		Max.	5.00	
Value Creation	Continuous	Min.	1.10	
		Mean	3.92	
		Max.	5.00	

A. Data Analysis

Data analysis was carried out to determine the moderating effect of variables representing personal characteristics of respondents and their influence on the relationship between adoption of the telecentre and value creation. According to Baron and Kenny (1986) a moderator variable is a qualitative or quantitative variable that affects the direction and/or strength of the relationship between an independent variable and a dependent variable. Hence, in this study the first hypothesis (H_1) is to determine whether the relationship between adoption and value creation is different for young and elderly people. Likewise, the second hypothesis (H_2) is to determine whether the relationship between adoption and value creation is different for male and female respondents. The third hypothesis (H_3) is to determine whether marital status affects the relationship between adoption and value creation. Whereas hypothesis 4 (H_4) is to examine whether the relationship between adoption and value creation is affected by whether a person is educated or not. It is also interesting to test for hypothesis 5 (H_5) to determine whether family size has an effect on the relationship between adoption and value creation. Equally interesting is to study the effect of household income and its influence on adoption and value creation as formulated in hypothesis 6 (H_6). The seventh hypothesis (H_7) is to determine whether the influence of adoption on value creation is different between owners of PC and non-owners. Lastly hypothesis 8 (H_8) is to determine whether there is a different effect in usage experience on adoption and value creation.

To test these hypotheses, moderated multiple regression was carried out with value creation as the dependent variable, adoption as independent variable, and variables representing the personal characteristics as the candidate moderator variables. However, before moderating analysis can be done, eight assumptions of multivariate analysis will have to be met. These assumptions are listed in Table 2 along with the corresponding evidence from performing the exploratory data analysis on the sample data.

Table 2. Assumptions for Moderated Multiple Regression

Assumptions	
Assumption 1	Dependent variable should be measured on a continuous scale.
Assumption 2	Independent variable should be continuous and moderator variables are dichotomous.
Assumption 3	Independence of observations (i.e., independence of residuals).
Assumption 4	There needs to be a linear relationship between the dependent variable and the independent variable for each group of the dichotomous moderator variable.
Assumption 5	Homoscedasticity or homogeneity of variance, which is when the error variances are the same for all combinations of dependent and moderator variables.
Assumption 6	No multicollinearity issue.
Assumption 7	No significant outliers.
Assumption 8	Residuals (errors) are approximately normally distributed.

Assumptions 1 and 2 were met as presented in Table 1. Independence of observations for Assumption 3 used the Durbin-Watson residuals computed as part of the linear regression analysis. The result shows a value of 1.90 which is well within the recommended range of 1.5 to 2.5. For Assumption 4, the strategy for determining whether or not a relationship is linear is based on significance tests for the Pearson r correlation coefficient. If the correlation coefficient between an independent variable and a dependent variable is statistically significant (its probability is less than or equal 0.05 level of significance), we will conclude that the relationship is linear. The data set was split into the different personal characteristics categories representing the two groups of the dichotomous variables. The Pearson Correlation for all groups is significant, therefore, the assumption of linearity is evidenced.

For Assumption 5, Levene statistic was used to test for homoscedasticity. Test of homogeneity of variances was carried out across the groups for combination of the moderating variables and the dependent variable. To carry out this procedure, homogeneity of variance test using the one-way ANOVA was carried out with the dependent variable ValueCreation fitted with the moderating variable as the factor variable. The null hypothesis for the test of homogeneity of variance states that the variance of the dependent variable is equal across groups defined by the independent (moderating) variable, i.e., the variance is homogeneous.

The results for age, gender, marital, and PC ownership categories, show that the probability

associated with Levene statistic is greater than the significant level ($p > 0.05$), hence fail to reject the null hypothesis and conclude that the variance is homogeneous. On the other hand, Education, Family, Income and Usage categories show that the probability of the Levene statistic is less than the significant level ($p < 0.05$), hence the null hypothesis was rejected and conclude that the variance is not homogeneous.

For Assumption 6, multicollinearity can be determined by performing linear regression on the independent variable Adoption and Value Creation for each group of the data set and check for collinearity diagnostic. A Variance Inflation Factor or VIF of greater than 5 is generally considered evidence of multicollinearity. The results show VIF of 1 across all the variables.

Assumption 7 deals with extreme outliers, which are data points that appear to be significantly different than the majority of the data. Outliers for the dependent variable were detected by taking the difference between the first and third quartiles and multiply by a multiplier factor (g) of 2.2, adding its product to the third quartile for the upper limit and subtracting from the first quartile for the lower limit of the data point (Hoaglin and Iglewicz, 1987). Data points exceeded the upper limit or less than the lower limit were considered extreme outliers. These were then replaced with the mean and the process was repeated until no extreme outliers detected in the data set. The extreme values were all within the upper and lower bounds which meet the condition set by Assumption 7.

Assumption 8 requires that the residuals are normally distributed. Residuals are gaps between actual dependent variable less its estimated values. The residuals should be normally distributed for regression to proceed. The Shapiro-Wilks test of normality was conducted on the standardized residuals with adoption predicting value creation. The result shows a p -value < 0.05 indicating the null hypothesis was rejected which indicates the residuals are not normally distributed. However, a visual inspection of the normality plot shows an indication of normality in the residual distribution. Figure 2 shows the histogram for the normality plot.

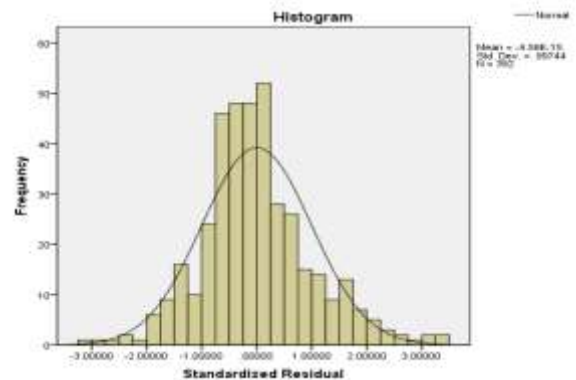

Figure 2. Normality Plot

Since four of the eight variables of personal characteristics were supported, moderation analysis was carried out on these four variables, namely Age, Gender, Marital Status and PC Ownership. With all the eight assumptions satisfied, it is now possible to carry out the moderated multiple regression.

III. FINDINGS

H1: Age moderates the effect of adoption on Telecentre Value Creation.

The results show a significant model fit with $R^2 = .794$ and a significant interaction variable ($p=0.000$), hence hypothesis 1 is supported, that is, age moderates the effect of adoption of the telecentre on value creation. Since the coefficient of the interaction variable Product (-.074) is negative and the moderator variable AgeCat (-.044) is also negative, there is negative effect of adoption on value creation. The negative coefficient of the moderator variable suggests young people (the direction moving from old (1) to young (0)) tend to decrease value creation resulting from adoption of the telecentre.

H2: Gender moderates the effect of adoption on Telecentre Value Creation.

The results show a significant model fit with $R^2 = .796$ and a significant interaction variable ($p=0.000$), hence hypothesis 2 is supported, that is, gender moderates the effect of adoption of the telecentre on value creation. Since the coefficient of the interaction variable Product (-.074) is negative and the moderator variable GenderCat (.072) is positive, there is negative effect of adoption on value creation. The positive coefficient of the moderator variable suggests male gender (the direction moving from female (0) to male (1)) tend to decrease value creation resulting from adoption of the telecentre.

H3: Marital Status moderates the effect of adoption on Telecentre Value Creation.

The results show a significant model fit with $R^2 = .794$ and a significant interaction variable ($p=0.000$), hence

hypothesis 3 is supported, that is, marital status moderates the effect of adoption of the telecentre on value creation. Since the coefficient of the interaction variable Product (-.074) is negative and the moderator variable MaritalCat (.002) is positive, there is negative effect of adoption on value creation. The positive coefficient of the moderator variable suggests married people (the direction moving from single (0) to married (1)) tend to decrease value creation resulting from adoption of the telecentre.

H7: PC Ownership moderates the effect of adoption on Telecentre Value Creation.

The results show a significant model fit with $R^2 = .794$ and a significant interaction variable ($p=0.000$), hence hypothesis 7 is supported, that is, PC ownership moderates the effect of adoption of the telecentre on value creation. Since the coefficient of the interaction variable Product (-.073) is negative and the moderator variable PCcat (-.015) is also negative, there is negative effect of adoption on value creation. The negative coefficient of the moderator variable suggests people with no PC (the direction moving from Yes (1) to No (0)) tend to decrease value creation resulting from adoption of the telecentre.

IV. CONCLUSION

The results of this study show certain aspects of personal characteristics have significant moderating role on the effect of adoption of a telecentre on a community socio-economic value creation. In particular age, gender, marital status and PC ownership tend to moderate the relationship between adoption of the telecentre and value creation. Examining the age category, this study found young people tend to have negative effect on value creation when adopting the telecentre. In the gender category, finding of this study indicates males tend to decrease value that can be created when adopting telecentre.

This study also found marital status to be a significant moderator, in which married people tend to contribute less when adopting the telecentre. In terms of PC ownership, this study found people with no PC tend to contribute less to the value that can be created when using the telecentre. Other personal characteristics such as education level, family size, income and frequency of use were found not to have significant moderating effect on the relationship between adoption and value creation.

Overall, results of this study may throw some light on sustainability of the telecentre in terms of socio-economic value creation with certain personal characteristics of the community. Past studies have

shown positive significant relationship between adoption and value creation. This trend is expected to continue to grow in the future.

With additional hindsight from this study, telecentre managers and stakeholders can make necessary adjustments in formulating programs for telecentres based on personal demography as suggested by Hansson et al. (2010), Ray and Prasad (2014) and Zulkhairi et al. (2015). This will further enhance the national policy on bridging the digital divide that specifies adoption of the telecentre as having higher socio-economic impact as described in the National Strategic Framework for Bridging the Digital Divide.

Future work can extend this study by examining the other personal characteristics not found to be significant moderators by transforming the variables in satisfying the multivariate assumption of homoscedasticity that was not supported in this study.

VI ACKNOWLEDGMENT

The authors would like to thank Universiti Utara Malaysia for providing the research grant to carry out the study under the high-impact category.

REFERENCES

- Abu Samah, B., Badsar, M., Abu Hassan, M., Osman, N., Shaffril, M., & Azril, H. (2013). Youth and telecentres in community building in rural Peninsular Malaysia. *Pertanika Journal of Social Sciences & Humanities*, 21(spec. July), 67-78.
- Attwood, H., Diga, K., Braathen, E., & May, J. (2013). Telecentre functionality in South Africa: Re-enabling the community ICT access environment. *The Journal of Community Informatics*, 9(4).
- Bailey, A. (2009). Issues Affecting the Social Sustainability of Telecentres in Developing Contexts: A Field Study of Sixteen Telecentres in Jamaica. *The Electronic Journal on Information Systems in Developing Countries (EJISDC)*, 36 (4), 1-18.
- Bailey, A. and Ngwenyama, O. (2009). Social Ties, Literacy, Location and Perception of Economic Opportunity: Factors Influencing Telecentre Success in a Development Context. 42nd Hawaii International Conference on System Sciences, HICSS 42, Hawaii.
- Bailey, A. and Ngwenyama, O. (2010). Bridging the generation gap in ICT use: Interrogating identity, technology and interactions in community telecenters. *Information Technology for Development*, 16 (1), 62-82.
- Baron, R. M., and Kenny, D. A. (1986). The moderator-mediator variable distinction in social psychological research: Conceptual, strategic and statistical considerations. *Journal of Personality and Social Psychology*, 51, 1173-1182.
- Economic Planning Unit (EPU) (2007). *Rangka Kerja Strategik Kebangsaan bagi Merapatkan Jurang Digital (NSF-BDD)*, presented at Bengkel Pusat Perkhidmatan dan Ilmu Komuniti Peringkat Negeri Pulau Pinang, 13 Jun 2007.
- Frias, M.A.E, Peres, H.H.C., Paranhos, W.Y., Leite, M.M.J., Prado, C., Kurcgant, P., Tronchin, D.M.R. and Melleiro, M.M. (2011). The use of computer tools by the elderly of a Center of Reference and Citizenship for the Elderly, *Rev Esc Enferm USP*, 2011; 45(Esp):1606-12, retrieved October 1, 2012 from http://www.scielo.br/pdf/reusp/v45nspe/en_v45nspea11.pdf.
- Gomez, R. (2014). When you do not have a computer: Public-access computing in developing countries. *Information Technology for Development*, 20(3), 274-291.

- Gomez, R. and Camacho, K. (2013). Users of ICT at Public Access Centers: Age, Education, Gender, and Income Differences. In Chhabra, S. (ed), ICT Influences on Human Development, Interaction, and Collaboration (1-21). IGI Global.
- Gomez, R. and Gould, E. (2010). The “cool factor” of Public Access to ICT Users’ Perceptions of Trust in Libraries, Telecentres and Cybercafe’s in Developing Countries, *Information Technology & People*, 23 (3), 247-264.
- Hair, J.F., Black, W., Babin, B., Anderson, R. and Tatham, R. (2006). *Multivariate Data Analysis*. Prentice Hall, Inc.: Upper Saddle River, NJ, USA.
- Hansson, H., Mozelius, P., Gaiani, S. and Meegamma, N. (2010). Women Empowerment in Rural Areas through the Usage of Telecentres - A Sri Lankan Case Study. 2010 International Conference on Advances in ICT for Emerging Regions (ICTer), IEEE, 5-10.
- Hoaglin, D.C. & Iglewicz, B. (1987). Fine tuning some resistant rules for outlier labelling, *Journal of American Statistical Association*, 82, 1147-1149.
- Johansson Hedberg, L. (2011). Telecentre For Community Development: Evaluation of the Tunjang telecentre, Malaysia. *The Journal of Community Informatics*, 6(2).
- Kumar, R. and Best, M. (2006). “Social Impact and Diffusion of Telecenter Use: A Study from the Sustainable Access in Rural India Project”, *Journal of Community Informatics*, 2(3).
- Kyobe, M. (2011). Investigating the key factors influencing ICT adoption in South Africa. *Journal of systems and information technology*, 13(3), 255-267.
- Lesame, N.C. (2008). The Impact of Information and Communication Technologies (ICTs) on Development: A Case Study of the Influence of Telecentres on The Education of Users, PhD Thesis, University of South Africa.
- Mbatha, B. (2015). Pushing the agenda of the information society ICT diffusion in selected multipurpose community telecentres in South Africa. *Information Development*, Doi:10.1177/0266666915575544.
- Mohamad Amir Abu Seman, Huda Ibrahim, Mohd Khairudin Kasiran, Nor Iadah Yusop, Zahurin Mat Aji, Zulkhairi Md. Dahalin and Azman Yasin. (2012). Community Characteristics for Self-Funding and Self-Sustainable Telecenter, *AWERProcedia Information Technology & Computer Science*. [Online]. 2013, 3, 1666-1671. Available from: [http://www.world-education-center.org/index.php/P-ITCSPProceedings of 3 rd World Conference on Information Technology \(WCIT-2012\), 14-16 November 2012, University of Barcelon, Barcelona, Spain](http://www.world-education-center.org/index.php/P-ITCSPProceedings of 3 rd World Conference on Information Technology (WCIT-2012), 14-16 November 2012, University of Barcelon, Barcelona, Spain).
- Mohammad Badsar, Bahaman Abu Samah, Musa Abu Hassan, Nizam Bin Osman and Hayrol Azril Mohd Shaffri (2011). Social Sustainability of Information and Communication Technology (ICT) Telecentres in Rural Communities in Malaysia Australian, *Journal of Basic and Applied Sciences*, 5(12): 2929-2938.
- Mukerji, M. (2009). ICTs and development: A study of telecenters in rural India. Doctorial Colloquium. 10th International Conference on Social Implications of Computers in Developing Countries, Dubai, United Arab Emirates.
- Nor Iadah Yusop, Faudziah Ahmad, Zahurin Mat Aji and Azizi Ab Aziz (February 2015). A Computational Model for Dynamics in Effective Usage of ICT Public Access Centre. *ARNP Journal of Engineering and Applied Sciences*, 10 (3), 1494-1498.
- Prado, P., & Janbek, D. M. (2012). Telecenter Web Portals in Latin American and Arab Nations: A Comparative Analysis. *The Journal of Community Informatics*, 9(1).
- Rajapakse, J. (2012, August). Impact of telecentres on Sri Lankan society. Paper presented in 8th International Conference on Computing and Networking Technology (ICCNT), 2012, pp. 281-286, IEEE.
- Ray, R.S. and Prasad, R. (2014). Telecentres Go Where Mobile Phones Fear to Tread Evidence from India. *Review of Market Integration*, 6(1), 62-95.
- Rogers, E.M.(2003). *Diffusion of Innovations* (5th Edition), New York Free Press.
- Terry, A., & Gomez, R. (2011, January). Gender and public access computing: An international perspective. In *System Sciences (HICSS)*, 2011 44th Hawaii International Conference on (pp. 1-11). IEEE.
- Walsham, G. (2010). ICTs for the Broader Development of India: An Analysis of the Literature, *European Journal of Information Systems in Developing Countries (EJISDC)* 41(4), 1-20.
- Yogeeswaran, K. (2007). National Strategic Framework for Bridging the Digital Divide and the Need for Upgrading and Expanding ICT Infrastructure. *MyBroadband 2007 Conference and Exhibition 10-12 Sept 2007, MATRADE Exhibition & Convention Centre, Kuala Lumpur*.
- Zahurin Mat Aji (2014). An Investigation on Individual Empowerment of Telecentres Users: A Case Study of Three Pusat Internet Desa (PIDs) in Northern States of Malaysia. *Universiti Utara Malaysia*.
- Zulkhairi Md Dahalin, Huda Ibrahim, Md Zahir Mat Cha, Nor Iadah Yusop, Nafishah Othman, Zahurin Mat Aji, Mohamad Amir Abu Seman, Mohd Khairudin Kasiran, Abdul Jaleel Kehinde Shittu and Azman Yasin (2012). A Model of Institution of Higher Learning and Community Collaboration for the Development of eCommunity. *Proceedings of the 19th International Business Information Management Association (IBIMA) Conference, 12-13 November, Barcelona, Spain*.
- Zulkhairi Md. Dahalin, Huda Hj. Ibrahim, Nor Iadah Yusop, Mohd Khairudin Kasiran, Zahurin Mat Aji, and Nafishah Othman (2012). A Telecentre Ecosystem for Diffusion and Adoption. *Proceedings of 3rd International Soft Science Conference (ISSC) 2012, 6-8 November, Phnom Penh City, Cambodia*, 99-103.
- Zulkhairi Md. Dahalin, Nor Iadah Yusop, Huda, Ibrahim, Mohd. Khairudin, Kasiran, & Zahurin, Mat Aji (2009). Socio-economic Benefits of Telecentre Implementation in Peninsular Malaysia. *Proceedings of the International Conference of Computing and Informatics 2009 (ICOCI09), Legend Hotel, Kuala Lumpur, 24 – 25 June*.
- Zulkhairi Md Dahalin, Nor Iadah Yusop, Huda Ibrahim, Zahurin Mat Aji, Nafishah Othman, Rosmadi Bakar, Yussalita Md Yussop and Mohd Khairudin Kasiran (2015). A Test Model for Telecentre Value Creation, *Proceedings of the 5th International Conference on Computing and Informatics, ICOCI 2015, 11-12 August, 2015 Istanbul, Turkey*, 551-556.

Multi perspective Analysis the WiFi Performance and Evaluation: Case Study Songkhla Rajabhat University

Sasalak Tongkaw, and Aumnat Tongkaw

Songkhla Rajabhat University, Thailand, sasalak.to@skru.ac.th

ABSTRACT

This paper presents the concepts of the Wi-Fi device implementation. The data collected from the measurement of quality and stability of broadcasting signals, single and multi-channels of access point, at the computer center building, Songkhla Rajabhat University. Moreover, the research analyzed content analysis of interviewed data from administrators, lecturers and students in the university. The result demonstrates that both single and multi-channel have no significant difference in terms of signal quality. However, the results show that the suitable implementation Wi-Fi devices should consider technical perspective, organizational perspective and personal perspective as well.

Keywords: Access Point, Multi-Channel, Multiple perspective.

I INTRODUCTION

Today, most of the Internet Service Provider designed and installed the access points for broadcasting wireless signal in public area. The devices were developed for transmitting both single channel and multiple channels. Most universities have invested to install wireless Internet system infrastructure to increase the efficiency of services provided across every point in the university. Songkhla Rajabhat University, which is located in the main campus in Songkhla province. There is a need to invest in modern technology and equipment installation (Tongkaw, 2013). However, the quality of wireless Internet service in Songkhla Rajabhat University is poor. In addition, it is still has problems related on the stability of the service. According from these points, there is a need to determine the main key factors that contribute to the problem in any perspectives concerning the connection of the Wi-Fi to conceptualize the solution.

Currently, Songkhla Rajabhat University has installed a wireless access point covered 60% of area including inside all buildings. The WiFi devices were set up and provide wireless network services with many access points to facilitate the students, lecturers, and staffs of the university. To ease the operation, the performance of the wireless network in the campus such as test strength and speed of data transmission will be monitored by the computer Center. To increase the

performance of the service, the Center need to provide the real-time monitoring and assess the wireless system performance report. Through the use of testing for speed and signal strength of the wireless network, the access point can be measured. By testing for speed and signal strength of wireless networks, the access point each of which is measured in decibels (db) stability testing of network access between each point across Songkhla Rajabhat University. This research is a part of the project that provided the concept of measurement and installation in the current status.

Although, a Wi-Fi indoor research proposed that WiFi-based positioning approach can achieve one meter accuracy without any hardware change in commercial WiFi products, which is much better than the conventional solutions from both academia and industry concerning the trade-off of cost and system complexity (Yang & Shao, 2015), Songkhla Rajabhat University implemented WiFi both indoor and outdoor. This research may be useful to the University in terms of planning installations wireless networks in the future, and to optimize the service sustainable.

The objective of this research is to identify the key factors of the problems in the installation of a wireless network of Songkhla Rajabhat University, to create a conceptual framework for the installation of a wireless network in Songkhla Rajabhat University, and join information that helps to improve system planning and installation of a wireless network for the project in the near future. This paper will outline the research method and briefly describe the research study including the Technical system, Organization system and Personal system, as well as outlining the research results and discussion.

II RESEARCH METHOD

Mixed methods take advantage of using multiple ways to explore a research problem. Data collection can involve any technique available to researchers. Moreover, the interpretation of mix methods could be continual and can influence stages in the research process. Therefore, to conduct this research, the researchers used mix methods because of research that can be studied in depth by collecting data from both quantitative and qualitative data. Both types of data could support each other to describe the concept or framework deeply which will be the new knowledge research (John W. Creswell, 2007).

Maya Lin (2007) conducting research in regards to IVT in schools use qualitative research methods. Many researches can collect in-depth information from the relevant target groups. The researchers will be involved every step of the process data. The data analysis used in this study, the researchers analyzed data template (Template Analysis), because it can analyze data from a wide range of target groups (King, 2004).

A. Multiple perspective Model

This research introduced and employed Multi perspective model, a model was developed in the USA by Linstone (2002) in order to check the installation of the IT organization, a complex of installing IT systems. Songkhla Rajabhat University was held that the brand of access points are expanding rapidly. That cause the complex system network architecture in particular building such as the energy systems, as well as those related to the entire system.

Multiple perspective model is a model that may be taken from the perspective of three areas: Organization system, Technical System and Personal System were analyzed for factors associated with the development of the entire system. The Multiple perspective model, which may also explain the concept of systems thinking.

B. TOP Model

Researchers in England Professor Wood River's Cooper and colleagues (A. T. Wood-Harper, Steve, J. R. G. Wood, & Heather, 1996)(Wood-Harper et al., 1996) using the Multiple perspective model in the May issue of the installation of the IT organization. Results of the research showed that the Organization system (O) and a Personal System (P) are overlapping with Technical Systems (T) also note factors of issues related to corporate Organization system (O) and the related Personal system (P) can be used to help solve the problem of complex IT systems have also Fred Hendrix Sun (Fredriksson, 2008) researchers from Australia.

Cooper has used Multiple perspective model in the May issue of the installation of IT departments in educational research activities keeping in mind the condition guidelines and other factors that develop IT systems have the effect of driving to school, which research has shown that factors outside the school. Within the study, the researchers analyzed the factors that occur at different levels. A highly addition can be used Multiple perspective model to study the problem of installing IT systems in government departments and the private sector make aware of the installation of all IT systems (Metcalf & Hobson, 2001). The problem arises from the plan it at different levels down to the level practitioners. Moreover, Multiple perspective model can use to test the installation of IT

systems. The model is a clear pattern in the factors of the problem. The model can also explain the problem of complexity involved in the technical organization and the people involved in that project. The Multiple perspective model may also explain the depth of the problem in the culture of the organization as well.

III RESULTS AND DISCUSSION

The results could be separated into three parts: Technical perspective (T), Organizational perspective (O), and Personal perspective (P). The details show as following:

A. Technical Perspective :

To test the strength the signal and the brand of access point, this research collected WiFi signal measurement data by using two WiFi application software types. The WiFi signal was tested by using Homedale 1.41, showed in Figure 1, WiFi Analyzer 3.5.2, showed in Figure 2, SIP phone Application (Zoiper), Ekahau Heatmapper, and WireShark showed in Figure 3. The test was repeated by 5 minutes gap in the same access point for five times.

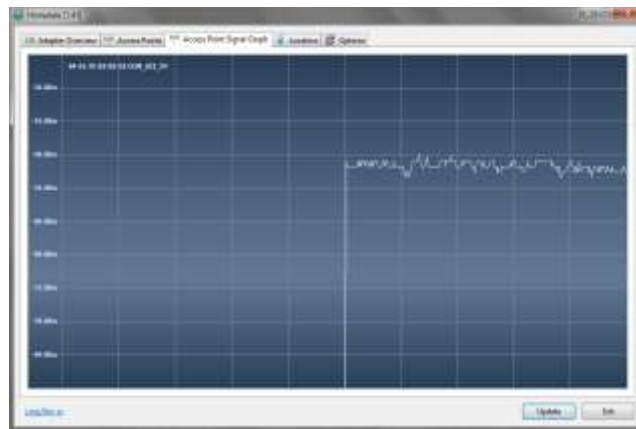

Figure 1. A Homedale 1.41 program shows AP Signal Graph



Figure 2. A WiFi Analyzer 3.5.2 program shows AP Signal Graph

Figure 2 shows that the various signal of each access points appeared in different colors and the moving

graph because it is not stable, they are moving during the testing device move around.

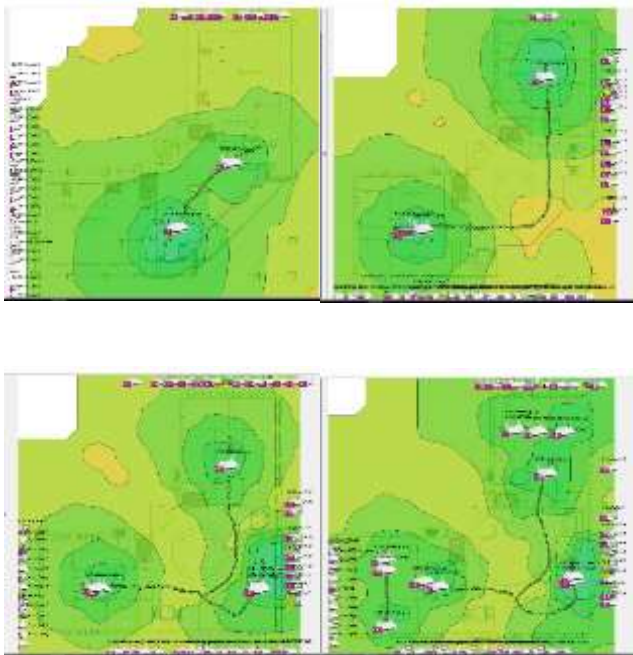

Figure 3. An Ekahau Heatmapper program shows AP Signal Graph

To test the strength of the signal, this research used Ekahau Heatmapper software to show the intensity of the signal in space per square meter, the software was installed in the notebook together with software WireShark which used to trap packet of SIP phone application. The process of testing signal, this research used a smart phone and a notebook detected the signal simultaneously when moving from one point to another point. When moving mobile receiver away, the broadcast signals are weak and the receiver signal will try to attach another point. This research capture the signal every 3-meters. Figure 3 shows signal level of service Hotspot (WiFi) signal of each floor of the building.

Strength of the signal is divided into four levels, showed in Table 1.

Table 1. The strength of signal

DB	Stability	Color
(-40db) to (-35db)	Very good	Dark green
(-48db) to (-40db)	Good	Green
(-56db) to (-48db)	Moderate	Yellow-Green
(-64db) to (-56db)	Low	Orange

The results showed that the test signal level, which is in moderate and very good, made effective use of the Internet.

Test using software that needs the stability of a VoIP network with software SIP phone Application (Zoiper) to dial into the phone system within the university. By connecting through Hotspot (WiFi) and data capture software WireShark sample data for the SIP protocol contains : No., Time, Source, Destination, Protocol, Length, Info. Example shows in Figure 4

No.	Time	Source	Destination	Protocol	Length	Info
50	5.844141000	172.17.160.22	172.17.3.29	SIP/SDP	924	Status: 200OK
Frame 50: 924 bytes on wire (7392 bits), 924 bytes captured (7392 bits) on interface 0						
Ethernet II, Src: LiteonTe_38:f1:3d (74:e5:43:38:f1:3d), Dst: RealtekU_5f:c9:a0 (52:54:00:5f:c9:a0)						
Internet Protocol Version 4, Src: 172.17.160.22 (172.17.160.22), Dst: 172.17.3.29 (172.17.3.29)						
User Datagram Protocol, Src Port: 61234 (61234), Dst Port: 5060 (5060)						
Session Initiation Protocol (200)						

Figure 4. SIP packet data of SIP phone application

For single channel, information from software WireShark able to create and implement the IO Graph graphing the relationship between the number of packets of Figure 5.

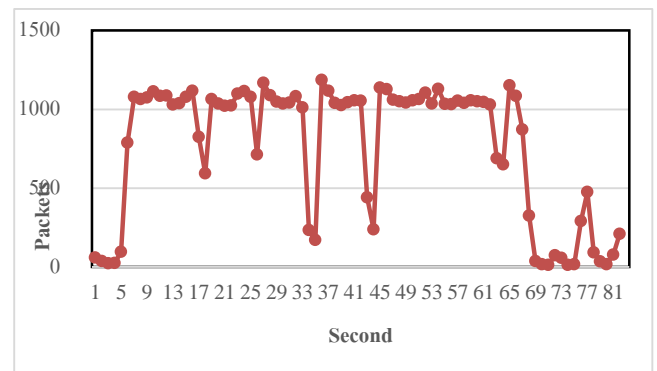

Figure 5. Single channel data send – receive using a SIP protocol

As a result of the summary data with software WireShark, data was sent – received continuously from first floor to the fourth floor, with a low data point is at 330-340 second for first time and for second time is at 420-430 second, where the second signal is low.

For multi channel Information from software WireShark able to create and implement the IO Graph graphing the relationship between the number of packets of Figure 6.

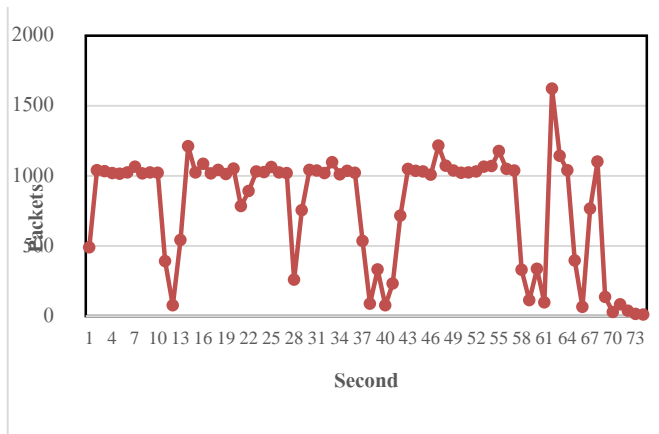

Figure 6. Multi-channel data send – receive using a SIP protocol

B. Organizational perspective (O)

The organization perspective focused on the policy of authentication lecturers, students, and guests. The university should create policy of installation for example the new WiFi devices. They should register and set up the network properly and they should not allow illegal access point installation. Moreover, in the past the university was contact by private ISP who would like to install their private access point. However, many problems come with the implementations for instance, the slow access and the balance of the traffic. Therefore, private ISP needs to have allowance to install. The recommendation is the new SSID on access point needs to set the configuration design by computer center only.

C. Personal perspective (P)

The personal perspective of the research came from interview administrators and staffs data, the provider of the wireless network. Some areas, which are not public areas, have trouble bringing access point to install. The services of illegal installments of private access point are cause-effect irritating signal overall Internet services cover Songkhla Rajabhat University. For public areas, the services are limited, so, administrators try to use software to help monitor. In running process, since 2009, number of the access points in process of broadcast service, are nearly 30, but the current rise up ten times, because of increasing of mobile devices. The demand of Internet access is higher. However, the number of devices is limited and the design is require to fit the budget.

For good quality services, Computer Center needs to add a number of access point equipment, but the research found out that in some areas, including the auditorium and active activities, there is a limit number of access points. Moreover, the access points did not suitable for public areas and they are not meet the Internet requirements. In addition, some specific applications may not be compatible with the access point. Then, the service administrators need to prepare

a budget proposal for the year. However, due to the limited number of administrator, as a result, the Internet services may not actives in some area. Currently, the supply of access points for installation is about 150, to serve area that covers the campus. The projects proposed to add high quality signal distribution equipment for areas with dense of access point numbers.

In the service, adding a number of access point in the area with out consider Multi perspective cannot make efficiency work because the signal through the network need to set the configuration. The more important thing to do is consider the budget for the core infrastructure for the distribution area. The installation of signal distribution must have access to the Internet signal to the above points and must be designed better services and network security.

This research can create a conceptual framework to guide research to improve and modify the installation of a wireless network at Songkhla Rajabhat University. It is also important for the referee to administer and manage technology in Songkhla Rajabhat University. The data allows the development of wireless networks in Songkhla Rajabhat University to be effective and sustainable. Moreover, this case study of Songkhla Rajabhat University showed the concepts of implementation to the staffs. Therefore, the staffs have implementation knowledge about how to install a wireless network within the university efficiently. And the findings have to be published for people who want to solve problems in installing wireless networks for the future.

ACKNOWLEDGMENT

This research supported by Faculty of Science and Technology, Songkhla Rajabhat University, Thailand.

REFERENCES

- Fredriksson, U. (2008). Innovative use of ICT in schools based on the findings in ELFE project. *Education and Information Technologies*, 13, 83.
- John W. Creswell. (2007). *Qualitative Inquiry & Research Design Choosing Among Five Approaches* (2nd ed.). London: Sage Publications, Inc.
- King, N. (2004). Using templates in the thematic analysis of text. In C. Cassell & G. Symon (Eds.), *Essential Guide to Qualitative Methods in Organizational Research*. (pp. 256–270). Sage.
- Linstone, H. A. (2002). The Multiple Perspective Concept With Applications to Technology Assessment and Other Decision Areas. *Technological Forecasting and Social Change*, 20, 275–325.
- Metcalfe, M., & Hobson, E. (2001). Concern solving not problem solving (pp. 455–461). Presented at the 12th Australasian Conference on Information Systems.
- Tongkaw, A. (2013). 3rd World Conference on Learning, Teaching and Educational Leadership Multi Perspective Integrations Information and Communication Technologies (ICTs) in Higher Education in Developing Countries: Case Study Thailand. *Procedia - Social and Behavioral Sciences*, 93, 1467 – 1472. <http://doi.org/http://dx.doi.org/10.1016/j.sbspro.2013.10.065>

- Wood-Harper, A. T, Steve, C., Wood, J. R. G. & Heather, W. (1996). How we profess: the ethical systems analyst. *Commun. ACM*, 39, 69–77. <http://doi.org/http://doi.acm.org/10.1145/227234.227244>
- Yalin, H. I. (2007). Barriers to Information and Communication Technologies Integration into Elementary Schools in Turkey. *Journal of Applied Sciences*, 7, 4036.
- Yang, C., & Shao, H. (2015). WiFi-based indoor positioning. *IEEE Communications Magazine*, 53(3), 150–157.

Social Media Literacy and Awareness of the Youth in Secondary school in Southern Thailand

Korawan Seubsom, and Nopparat Meeplat

Nakhon Si Thammarat Rajabhat University, Thailand, {Korawan_seu; Nopparat_Me@nstru.ac.th}

ABSTRACT

The paper presents the outcome of a research that investigates the social media literacy, and to assess the level of awareness of media literacy from young people in secondary schools. This study used mixed-method of both quantitative and quality research to collect data from four schools in Nakhon Si Thammarat Province. This study used activities – based with involves four levels of media literacy framework; access, analyze, evaluate and create. The data were collected after the respondents met all levels of media literacy framework. The results of this study found that most students know how to learn and use social media literacy as four levels; access, analyze, evaluate and create. But some students do not know about how to use social media as a benefit for classroom learning. They lacked awareness of the benefits and downsides of social media, parents should tell them how to learn and how to perceive the good things from social media.

Keywords: Online, Communication, Awareness, Perception

I INTRODUCTION

Today, social media has emerged as a popular medium for providing new sources of information and rapid communications, particularly during natural disasters (Yin, Lampert, Cameron, Robinson, & Power, 2012). According to Dabbagh and Kitsantas (2012) is the interaction among people in a virtual environment that facilitates the creation, sharing and exchange of content with other users. Kaplan and Haenlein (2010) noted social media can be defined as Internet applications based on Web 2.0 that allows for people to collaborate and share information online.

According to Cohen (2015) social media is a dominant force in the modern world that can change minds, catch more business, increase sales or build and shape a brand or business. Social media has an impact on every platform. The ten most popular social media sites are Facebook, Twitter, YouTube, LinkedIn, Pinterest, Google+, Tumblr, Instagram, Reddit and vk (eBizMBA, 2016). Facebook is the biggest social networking site with the largest number of users. There are currently more than 1 million small or medium sized businesses advertising on

Facebook. The American Academy of Pediatrics (2016) reports 22% of teenagers log on to their favorite social media site more than ten times a day, and more than half of adolescents log on to a social media site more than once a day. Seventy-five percent of teenagers now own cell phones and 25% use them for social media, 54% use them for texting, and 24% use them for instant messaging.

Whilst social media can be great fun and an inclusive way of connecting with other users there is a downside. Besides the benefits, there are also risks. The problems that occur with the youth are cyber bullying, privacy issues, sexting, excessive use and sleep deprivation. Whilst some parents use technology incredibly well and feel comfortable and capable with the programs and online venues that their children and adolescents are using, many are baffled by the online world and worry what their children are getting up to. Some parents may find it difficult to relate to their digitally savvy youngsters online for several reasons. Sometimes parents lack a basic understanding that kids' online lives are an extension of their offline lives. In the end the knowledge and technical skill gap between parents and youth creates a disconnection in how they participate in the online world together.

According to Lim and Yin (2011) the younger generation use social media in its various forms much easier and assimilate information at a faster rate than the older generation, but the question is do they possess appropriate literacy skills to benefit from the social media environments such as use social media to share knowledge between teachers and students. There is a growing use of social media in the educational setting and it has many benefits for learning. Teachers can create learning content and post it for students, encourage debate and answer questions. According to Almu and Buhari (2014), mobile phones increase the active participation for young people in secondary school students in their social life even during school hours. Almost all students used social media such as Facebook, YouTube, Line, etc. However, the issue for today is not about the benefits of social media but if it affects students' studies negatively or positively thereby decreasing or increasing their performance academically. Sometimes, students are not aware of,

or able to process, the information coming at them. Therefore, this study examines the perception and awareness of the young students in secondary school. The research objectives of this study are:

A. Research Objectives

The purpose of this study are to assess the social media literacy and level of awareness in using social media by young people in secondary school.

B. Research Hypotheses

The paper provides the two hypotheses as follows:

H₁ The impact of gender differences among respondents on the relationship between knowledge and awareness of social media literacy.

H₂ The impact of age differences among respondents on the relationship between knowledge and awareness of social media literacy.

II LITERATURE REVIEW

A. Social media

According to Wikipedia (2012), social media is the interaction among people in a virtual environment that facilitates the creation, sharing, and exchange of information and ideas (Odhiambo, 2012). Social media is a phenomenon that has drawn a lot of attention both to companies and individuals interacting on the networking landscape. Kaplan and Heinlein (2010) defines social media as internet applications based on Web 2.0 that enables users to create content and collaborate and share information online. Social media have several advantages and possibilities allowing ideas to spread faster than when content emerges from one source.

Odhiambo (2012) states that social media is a phenomenon that has become an important aspect in the marketing mix and is revolutionizing the way companies interact with customers. In addition, Sheedy (2011) says social media are Internet-based applications that build on the ideological and technological foundations of Web 2.0, which allows the creation and exchange of user-generated content. Consequently, this study would like to investigate the level of awareness of using social media.

B. Media Literacy

According to Thoman and Jolls (2005) media literacy is a framework to build an understanding of the role of a media society. There are five levels of the media literacy process, skills access, analyze, evaluate and create. While Peter (2009) reports that media literacy is the ability to access, analyze, evaluate and create messages across a variety of contexts.

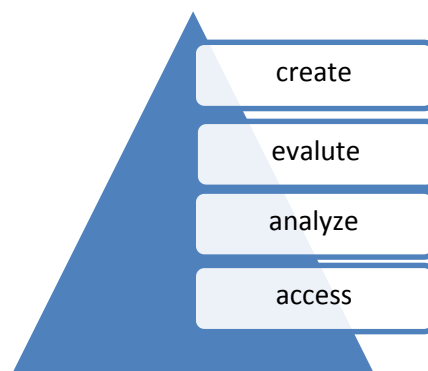

Figure 1 Media literacy framework

C. Social media awareness

According to Wikipedia (2009) awareness is the ability to directly know and perceive to feel or to be conscious of events, objects, thoughts, emotions, or sensory patterns. Therefore, this study would like to examine the social media awareness of young people in secondary schools.

III RESEARCH METHOD

This study employed mixed-method research using quantitative and qualitative research to collect data from four world-class standard schools in Nakhon Si Thammarat Rajabhat. The questionnaire was verified by three experts. One expert was from the Psychology program from Walailak University and two other experts came from the computer education program and innovation development program of Nakhon Si Thammarat Rajabhat University. The instrument was designed based on a social media literacy model as above; access, analyze, evaluate and create. In addition, this study includes understanding of social media. The Cronbach alpha was .723.

C. Sample Size and Sampling Techniques

This study used a purposive method to collect data from four world-class standard schools in Nakhon Si Thammarat. The sample group consisted of second year students in the secondary schools in Nakhon Si Thammarat Province.

B. Procedure and Data Collection

This study used a quantitative method to collect data from four world-class standard schools. Before collecting data, four events were set and transferred to all students to evaluate their perception and awareness. There are four steps of the media literacy framework used to assess media literacy and social media awareness from young people attending secondary school. The four steps are as follows:

1. The ability to access information through social media, Facebook, Line, YouTube etc.
2. The ability to analyze information through social media, Facebook, Line, YouTube etc.
3. The ability to evaluate information through social media when the students read or see the information.
4. The ability to create new information from social media.

IV DATA ANALYSIS

A process of data analysis was used to test the data based on the research objectives. Statistical analysis was conducted to test the two parts of the data. The first part was descriptive data as mean, standard deviation and percentage. The data analysis for two hypotheses were used t-test and Pearson correlation. The second part used content analysis to analyze the data.

D. Descriptive Analysis

Descriptive analysis describes the general statistical description of variables in the study such as demography of the respondents, the means, standard deviation and percentage.

Table 1 shows the gender of the sampling group. There are 49.2% of the respondents were male and 50.8% were female.

E. Results of the study

Table 1 Gender

Gender	Frequencies	Percentage
Male	61	49.2
Female	63	50.8
	124	100

Table 2 shows the demography of age. The age between 12-13 years old are 74.2% and 25.8% the age between 14-15 years old.

Table 2 Age

Age	Frequencies	Percentage
12-13	92	74.2
14-15	32	25.8
	124	100

Table 3 presents frequencies and percentage of each school. There are 49.2 percent from Benjamarachutit Nakhon Si Thammarat School while 26.6 percent from Chian Yai school. In addition, there are 17.7 percent from Muang school and 31.5 percent from Thasalaprasitusksa.

Table 3 Schools

School	Frequencies	Percentage
Benjamarachutit school	61	49.2
Chian Yai school	33	26.6
Muang school	22	17.7
Thasalaprasitusksa school	39	31.5
Total	124	100

F. Quantitative data

This study presents quantitative data regarding the knowledge of social media from students in secondary schools as follows:

Table 4 shows the mean and standard deviation of knowledge about social media from the respondents. 92.7% know the impact of social media for daily life, while 0.8% not agree and 6.5% are not sure. 81.5% know social media can communicate with people around the world, while 18.5% don't know. 87.1% know social media can be used to chat with friends, while 1.6% don't know and 11.3% are not sure. 71% of the students know Facebook is the most popular social media site and 56.5% can use Line to chat with friends.

Table 4. Knowledge about social media

List	No (%)	N/A (%)	Yes (%)
1. Social media impacts on your daily life.	0.8	6.5	92.7
2. Social media can communicate with people around the world	18.5	0	81.5
3. Social media can be used to chat with friends	1.6	11.3	87.1
4. Facebook is the most popular social media	0.8	28.2	71
5. Line is used to chat with friends.	4.8	38.7	56.5

Table 5 shows the level of awareness and social media literacy from second year students in secondary schools. There are 66.9% of students not agreeing when seeing advertising about free programs, while 24.2% are not sure and 8.9% agree. 69.4% of students thought that pills on ads on Facebook are not true. 28.2% are not sure and 8.9% of the students thought it true.

Table 5.the level of awareness and social media literacy

List	Disagree (%)	Not sure (%)	Argee (%)
1. When you see information on websites that are advertising the giveaway of free programs students should click through this website.	66.9	24.2	8.9
2. When students see an advert for pills on posting ads on Facebook students think that it is really possible.	69.4	28.2	2.4
3.If your friends are online We should give the address and telephone number	59.7	34.7	5.6
4. When you receive a message from an unknown person you should not read it immediately, because it may not be safe for the student's computer	14.5	21.8	41.9
5. You are currently in the chat room someone harasses you or is abusive. You should tell your parents	11.3	21.8	66.9
6. If someone would like to be your friend and asks for your photo, you should send it to him to know him better.	43.5	43.5	12.9
7. The users of social media should have knowledge of etiquette and creative use.	4.0	15.3	80.6
8. When you find a person with questionable behavior or who may be potentially harmful to others you should remain silent because the potential danger to himself.	29	36.3	34.7
9. Profanity or offensive words should not be used on Facebook	38.7	22.6	38.7
10. When you feel stressed or have problems you should share by posting on Facebook	56.5	33.9	9.7

59.7% of students thought they should not give an address and telephone number to strangers. 41.9% of students said that we should not read messages from strangers and 66.9% said that they should tell their parents if someone abuses them on Facebook. 43.5% of students do not agree with sending photos to strangers. 80.6 % said they should be honest and decent interactions when using social media. 36.6% feel not sure when they encounter suspicious people whether they should keep quiet or tell their parents. 38.7% of students did not agree to swear or use offensive words on Facebook when they feel upset. Finally, 56.9% of students did not agree to post on Facebook when they feel stressed or have problems.

D. Research Hypotheses Testing

This study provides three hypotheses about testing the different between gender, age, and school.

H1: The impact of gender are differences among respondents on the relationship between knowledge of social media.

Table 6 presents the Pearson correlation between gender, age, knowledge of social media and social media literacy awareness.

Table 6 the Pearson Correlation

	Gender	Age	knowledge	awareness
Gender	Pearson Correlation	1	.195*	.295**
	Sig. (2-tailed)			.001
	N	135	135	135
Age	Pearson Correlation	-.195*	1	.058
	Sig. (2-tailed)			.507
	N	135	135	135

*. Correlation is significant at the 0.05 level (2-tailed).

**. Correlation is significant at the 0.01 level (2-tailed).

Table 7 presents the difference knowledge of social media among male and female. The table presents the male (Mean = 5.246, SD. = .810) and female (Mean = 5.657, Sd. = .507). The results shows t -value (3.56) and P-value equal .001. Therefore, the knowledge of social media between male and female and significant at the level of p-value equal .001. The result shows females tend to have more knowledge of social media compared to males.

H2: The impact of age differences among respondents on the relationship between social media literacy awareness.

Table 7. There are difference among respondents on the relationship between knowledge of social media.

	Mean	S.D.	t	P-value
male	5.246	.810	3.56	.001
female	5.657	.507		

Table 8 presents the difference among respondents on the relationships between social media literacy awareness. The table presents the male (Mean = 3.24, SD. = 1.02) and female (Mean = 3.72, SD. = 1.25). The results shows t-value (2.176) and P-value equal .031. Therefore, the social media literacy awareness between ages are different and significant at the level of p-value equal .05 with higher age category having more awareness of social media literacy.

Table 8. The impact of age differences among respondents on the relationship between social media literacy awareness.

	Mean	S.D.	t	P-value
12-13	3.24	1.02	2.176	.031
14-15	3.72	1.25		

E. Qualitative data

This study used four activities regarding accessing, analyzing, evaluating and creating the information that students gained from social media. Figure 1 shows the activities from the four schools in this paper.



Figure 1. Social media activities in four world-class standard schools in Nakhon Si Thammarat Province.

Figure 1 shows the social media activities from students in our survey. After, the social media activities finished, the students discussed social media literacy. They thought social media is good for knowledge transfer and learning management. Most students know about advantages and disadvantages that come from using social media. They know how to externalize their Facebook page. Therefore, most students feel aware of using social media and can complete all levels of media literacy. However, some students did not know about this, thus, it is an issue incumbent on teachers and parents to provide good advice and guidance in how to use social media responsibly.

V DISCUSSION

Nowadays, social media impacts on everyone and every place such as in companies, business, government and education, whether individuals actively engage in social media or not. Amongst secondary school students this is palpable; using

social media is a hugely popular activity. Teenagers are highly motivated to keep up with trends in social media and ensure they fit in with their peers. According to this study, most students are very aware and know how to use social media but there are some who lack skills and knowledge, particularly to be safe online. Therefore, parents and teachers can provide good advice and guidance in how to use social media.

This study is in agreement with the American Academy of Pediatrics (2016) report about the impact of social media on children, adolescents and families. It is important that parents become aware of the nature of social media sites, given that not all of them are healthy environments for children and adolescents. However, the problem between children and parents is often because the parents lack a basic understanding that kids' online lives are an extension of their offline lives. Therefore, the important thing to consider is the knowledge and technical skill gap between parents and youth which creates a disconnect in how these parents and youth can participate in the online world together. Thus, Farah and Yanda (2015) suggest that the solution to solve these problems should be from the parents and educators such as parents should learn more about how to use social media and join their children's social networks and friends them. Then, parents will know the substance of what their children are saying and doing on these sites and can confront them about inappropriate behavior. Parents and educators should have an in prompt access to their children's mobile phones and laptops so as to know those they are chatting with the content. Parents and educator should remind their children not to post photos or content of nudity that could help strangers find them in the real world. Parents and educators should always monitor what media their children are using and accessing including any web sites that they visit and social networking site they may be using and parent should try to know the contents their children are consuming on social networking site. They should spare adequate time to watch the YouTube videos, look at their friends 'Facebook and play the games they play. Discussion content viewed online with them, does it agree with the known norm manners and values?

VI CONCLUSION

This study emphasizes the social media literacy and awareness of the youth in four world-class standard

schools in Nakhon Si Thammarat province. Most students know how to learn and use social media literacy as four levels; access, analyze, evaluate and create. But some students do not know about how to use social media as a benefit for classroom learning. They lack awareness of the benefits and downsides of social media. If parents and educators fail to grasp the concepts of social media, underestimate the importance of this phenomena to young people or even dismiss it altogether as trivial entertainment for immature 'kids' it will be a wedge in building understanding of the lives of young people in today's world.

ACKNOWLEDGMENT

Thank you for the Thailand research fund and all my teams and the students from four schools in Nakhon Si Thammarat Province. In addition, thank you very much to Prof. Dr. Zulkhairi Md Dahalin for your recommend on my paper.

REFERENCES

- Almu, A., & Buhari, B. A. (2014). Effect of Mobile Social Networks on Secondary School Students. *International Journal of Computer Science and Information technologies*, 5(5).
- American Academy of Pediatrics (2016). Clinical Report-The Impact of Social Media on Children, Adolescents and Families, American Academy of Pediatrics, Retrieved from <http://www.pediatrics.org/cgi/doi/10.1542/peds.2011-0054>.
- Cohen H.(2015). 2015 Small Business Social media Trends, Retrieved from <http://heidicohen.com/heid-cohen/>
- Dabbagh N. & Kitsantas A. (2016). Personal Learning Environments, social media, and self-regulated learning: A natural formula for connecting formal and informal learning, *The Internet and Higher Education*, 15(1), 3-8
- eBiz MBA (2016). Top 15 Most Popular Social Networking Sites, Retrieve, 6 May, 2016, from <http://www.ebizmba.com/articles/social-networking-websites>
- Farah. A.F.A. & Yanda.A.U.(2015). The use of social networking among Senior Secondary School Students in Abuja Municipal Area of Ferderal Captital Territory, Nigeria, *Journal of Education and Practice*, ISSN 2222-1735, (15).
- Kaplan, A. M., & Haenlein, M. (2010). Users of the world, unite! The challenges and opportunities of Social Media. *Business horizons*, 53(1), 59-68.
- Odhiambo, C. (2012). Social Media as a Tool of Marketing and Creating Brand Awareness. Unpublished master thesis, 109-127.
- Peter L. (2009). The regulator, the public and the media: imagining a role for the public in communication regulation, The London School of Economics and Political Science, Retrieved from <http://eprints.lse.ac.uk/24556/>.
- Potter, W. J. (2004). Theory of media literacy: A cognitive approach: Sage Publications.
- Sheedy, C. S. (2011). Social media for social change: A case study of social media use in the 2011 Egyptian revolution. Capstone Project. Retrieved from American.edu, website, <https://www.american.edu/soc/communication/upload/Caroline-Sheedy.pdf>
- Thoman E. & Joils (2005). Literacy for the 21st Century an Overview & Orientation Guide to Media Literacy Education, Center for Media Literacy, Retrieved from <http://www.medialit.org/>.
- Yin, J., Lampert, A., Cameron, M., Robinson, B., & Power, R. (2012). Using social media to enhance emergency situation awareness. *IEEE Intelligent Systems*, 27(6), 52-59.

Thai Word Segmentation on Social Networks with Time Sensitivity

Chirawan Ronran, Sayan Unankard, Wanvimol Nadee, Nongkran Khomwichai and Rangsit Sirirangsi

Maejo University, Thailand, {chirawan;sayan; wanvimon;nongkran_it, rangsit}@mju.ac.th

ABSTRACT

Social network service like Twitter is one of the important social networks that has had a huge impact on Thai culture. It has changed the behavior of many Thai people from using televisions to using computers or smart phones regularly. Thai people also share their experiences and get information such as news on social networks. With the increasing number of micro-blog messages that are originated and discussed over social networks, Thai word segmentation is becoming a compelling research issue as it is an important task in natural language processing. However, the existing Thai segmentation approaches are not designed to deal with short and noisy messages like Twitter. In this paper, we proposed Thai word segmentation on social networks approach by exploit both the local context (in tweets) and the global context from Thai Wikipedia. We evaluate our approach based on a real-world Twitter dataset. Our experiments show that the proposed approach can effectively segment Twitter messages over the baseline.

Keywords: Thai Segmentation, Tokenization, Social Network, Time Sensitivity.

I INTRODUCTION

In the present age, social networks have become the most popular way of communication for the current generation. The number of social network activities has increased dramatically, for example, information sharing, daily conversation and spreading news. Social network services provide a wealth of current topics which are discussed in social networks communities. Micro-blog like Twitter is being considered as a powerful means of communicating for Thai people looking to share and exchange information on a wide variety of topics. In 2015, the service rapidly gained worldwide popularity, with more than 4.5 million users who posted 3.4 million tweets in Thai⁷.

The fast information sharing on Twitter from millions of users all over the world leads to almost real-time reporting of events or topics (Li et al., 2012; Mathioudakis and Koudas, 2010; Unankard et al.,

2015). This strong temporal nature of shared information allows for the detection of significant events in the data stream. Therefore, before we can successfully identify events in social networks, we must understand how to segment Thai word from Twitter as it is an important task in natural language processing. Dealing with Thai language is more complex than English. Thai language does not have any explicit word boundary delimiters. Existing studies have focused on using a dictionary-based approach (Poowarawan, 1986; Sornlertlamvanich, 1993) however, the results rely on dictionary they have. On the other hand, using machine learning based approach has been studied in different ways (Haruechaiyasak et al., 2008; Limcharoen et al., 2009; Manning and Schutze, 1999). However, the approaches relies on having labelled data to train a classifier and it is not clear if retraining the classifier is needed.

Due to the characteristics of micro-blog messages in Thai, abbreviations and slang words are widely used in a message which cannot found in Thai dictionary (i.e., unknown word problem). Thus, we cannot rely on dictionary based approach. Also, labelled data is very expensive and time consuming process for training the model when supervised learning is applied. Therefore, the challenges of this paper are follows: (1) how to effectively segment Thai words in micro-blogs? (2) how to incorporate the local context (in Twitter) and the global context (from Thai Wikipedia) for Thai word segmentation task?

To our best knowledge, this paper is the first to fully focus on Thai word segmentation in social networks. The main contributions of this paper are as follows. (1) We present an approach to segment Thai word in micro-blogs (i.e., Twitter). (2) Local and global contexts are incorporated to improve the Thai segmentation. We evaluate our proposed approach with a real-world Twitter data posted by Thai-based users.

The rest of the paper is organized as follows. First, we describe the related work in Section II. Second, the proposed approach is presented in Section III. Third, we present the experimental setup and results in Section IV. Finally, the conclusions are given in Section V.

⁷ <http://syndacast.com/infographic-online-marketing-thailand-the-state-of-social-media/>

II RELATED WORKS

Typically, word or text segmentation play importance roles in natural language processing (NLP). The concept of word segmentation is applied in different languages such as English, Thai, Chinese and Japanese. In this paper, we focus on finding a method to improve Thai word segmentation (Haruechaiyasak et al., 2008a). In general, a sequence of Thai words in sentence is written similar writing an English sentence. However, the processing text segmentation in Thai language is not easy as English Language. Due to Thai language does not use any delimiter to specify the explicit word boundary. It makes the word boundaries are ambiguous. Consequently, the meaning of words and phrases could be different from the meaning of its part. Other problems happen when a new word is formed by combining a few words into a compound word. This situation does not only generate the ambiguity problem, but it also generates the unknown word problem and the new word problem in input text (Limcharoen et al., 2009). The systems cannot find these words in dictionary, thereby the segmentation results may not be accurate.

Recently, there are many works related to Thai word segmentation tasks. They try to develop the algorithms or techniques to find Thai word boundaries to make the better segmentation results. In previous works, most word segmentation approaches rely on two main approaches: dictionary based and machine learning based. Dictionary based approaches use a set of words or terms from a dictionary for making word segmentation (Aroonmanakun et al., 2007; Phaholphinyo and Kosawat, 2011). Therefore, this approach requires making a list of words in advance. Poowarawan (1986) proposed the longest matching algorithm which based on dictionary based approach to solve the ambiguity of words (Poowarawan, 1986). In addition, the ambiguity can be solved by using the maximum matching algorithm which splits a sequence of characters prior to segmentation based on a word set (Haruechaiyasak et al., 2008a; Sornlertlamvanich, 1993). However, the dictionary based approaches cannot handle the unknown word, or new word and ambiguity problems without adding these words into dictionary. To address the problem of unknown words for Thai language, the rule based is employed to build the segmentation techniques for a new word (Kawtrakul et al., 1997; Mahatthanachai et al., 2015; Palmer, 1997). The new words were created by combing the rule-based of characters and the rule-based of unknown words, but this approach is unable to wrap words when there were verbs appear between two unknown words. However, the rule-based approach cannot provide the high accuracy and requires hand-crafted rules resource (Khankasikam and Muansuwan, 2005).

Some studies suggested that the machine learning based approaches can improve the performance of the dictionary based approaches when these two problems exist in the systems (Haruechaiyasak et al., 2008a, b, 2006; Peng et al., 2004). Most machine learning based approaches algorithms are built under the statistical language modeling (LM) such as n-gram model (Manning and Schütze, 1999) and feature-based segmentation (Meknavin et al., 1997). N-gram model has been successful applied to many word segmentation problems (Silva et al., 1999). The models identify the word boundaries based on the feature of the characters surrounding the boundaries (Haruechaiyasak et al., 2008a; Limcharoen et al., 2009). Limcharoen et al. proposed a Thai word segmentation framework based on the combination of the concept of Thai Character Cluster (TCC) and word N-gram model to reduce the number of candidates and generate all possible word segmentation candidate (Limcharoen et al., 2009). This method does can be implemented without a dictionary for making word segmentation. Later, Theeramunknog et al. utilized the TCC to learn the word segmentation without dictionary by using the decision tree (Theeramunkong and Usanavasin, 2001).

However, some researcher argued that word segmentation is not the actual cause of the ambiguity problem, but this problem occurs from syllable segmentation (Aroonmanakun, 2002). Aroonmanakun proposed another word segmentation approach based on a syllable-based trigram model and maximum collocation. Author used a trigram model for syllable segmentation and determine word boundary and group syllables into words based on the idea of collocation (Aroonmanakun, 2002). Khankasikam et al. proposed another method to reduce the ambiguity problem by taking the semantics of words into consideration when making word segmentation (Khankasikam and Muansuwan, 2005).

To our best knowledge, this paper is the first to fully focus on Thai word segmentation in social networks. The main contributions of this paper are as follows. (1) We present an approach to segment Thai word in micro-blogs (i.e., Twitter). (2) Local and global contexts are incorporated to improve the Thai segmentation. We evaluate our proposed approach with a real-world Twitter data posted by Thai-based users.

III PROPOSED APPROACH

In order to provide a complete coverage of Thai word segmentation in social networks we proposed our system which has three stages presented in Figure 1. The following information provides detail of each stage.

A. Data Pre-processing

In particular dealing with micro-blog messages, the message is short and often noisy. In order to improve the quality of our dataset and the performance of the subsequent steps, the pre-processing was designed to remove irrelevant data e.g., re-tweet keyword, web address and message-mentioned username. A microblog loader is developed to collect the Twitter data from public users via the Twitter API service. The messages are removed by web addresses and the keyword RT(ReTweet) and the message-mentioned username such as “@username”.

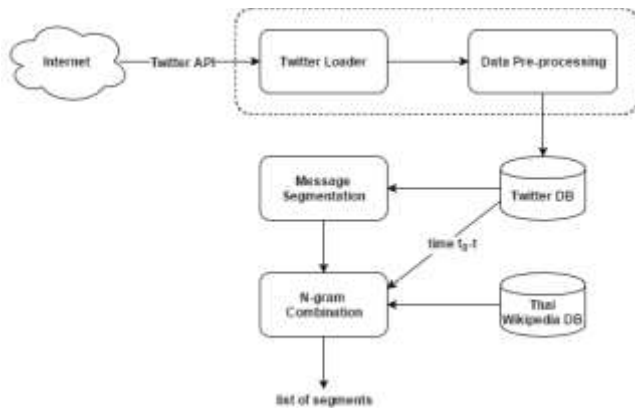

Fig. 1. Architecture Of Our System

B. Micro-blog Message Segmentation

The problem that we address in this section is how to segment Thai word in micro-blogs. Dealing with Thai language is more complex than English. Thai language does not have any explicit word boundary delimiters. The existing methods are unsuitable for dealing with Thai segmentation in micro-blog services. The example can be seen in Fig 2.

Original message: เผลอไปเจอคนเช็คอินเกาหลี [Scrolling on IG (Instagram) I found that a lot of people checked-in at Korea]
TLex: เผลอไปเจอคนเช็คอินเกาหลี [Scrolling on IG I found that a lot of people checked in at Korea]
Apache Lucene: เผลอไปเจอคนเช็คอินเกาหลี [Scrolling on IG I found that a lot of people checked-in at Korea]
Correct segments: เผลอไปเจอคนเช็คอินเกาหลี [Scrolling on IG I found that a lot of people checked-in at Korea]

Fig. 2. The example of existing Thai segmentation methods

Thai Lexeme Analyser (*TLex*) is an approach using Conditional Random Fields (CRFs) (Haruechaiyasak and Kongyoung, 2009). *TLex* performs well when articles contain grammatical, syntactical, and stylistic standards where the writing used has a different style from that used in the micro-blog messages. Micro-blog messages like Twitter usually contain the form of a short description or keyword tags. Abbreviations are also widely used in a message. Moreover, the

messages are often noisy. Therefore, *TLex* is not applicable for microblog messages due to its heavy dependence on local linguistic features.

In this stage, we aim to automatically segment micro-blog messages into words or phrases. Given an individual message m , the problem of message segmentation is to split m into k consecutive segments, $m = \{s_1, s_2, \dots, s_k\}$. Each segment s_i contains one or more words. To obtain the optimal segmentation, we adopt *ThaiAnalyzer* method provided by *Apache Lucene*⁸ for initial segmentation. Based on the observations, *Apache Lucene* sometime breaks a word apart incorrectly such as “โปรเจ็ค-Project” and “บางกอกแอร์เวย์-Bangkok Airway”. It splits “-Project” into two segments (i.e., “โปร-Pro”, “เจ็ค-ject”). Moreover, it sometime splits “บางกอกแอร์เวย์-Bangkok Airway” into two incorrect segments (i.e., “บาง-Bang”, “กอกแอร์เวย์-kok Airway”). In order to handle incorrect segmentation from Apache Lucene, we aggregate information in Twitter as local context and Thai Wikipedia as global context to compute the probability that a segment is a correct segment. By doing this, our approach is able to recognize new words or phrases, which may not appear in Thai dictionary.

Twitter dataset is crawled from the messages sent by users in Thailand, from the dates 17 April 2016 to 18 April 2016 with 175,294 messages. Re-tweet messages are excluded from our dataset. However, it is not necessary to consider the complete usage history of data from Twitter because of the fast information sharing on social networks. The topic may change over time. New words emerge and old ones are disappear. Two words co-occurred at time t may not appear together at time t_0 where $t_0 < t$. Therefore, previous Twitter messages (24 hours in our experiments) will be used as a local context to compute the probability that two or more words co-occur together. Thai Wikipedia data generated in February 2014 consist of 86,269 articles⁹ will be used as a global context.

Before we calculate n-grams probability in next step, we simply count the number of segments generated from Apache Lucene from both Twitter and Wikipedia. If the number of a segment found in both dataset less than the threshold, the more likely the segment is an incorrect segment. The threshold is defined as the minimum number of the segment is founded in the datasets. In this paper, our experiments shown that the threshold equals 4 give the best performance.

⁸ <https://lucene.apache.org>

⁹ http://www.e4thai.com/e4e/index.php?option=com_content&view=article&id=1320:2014-02-15-11-11-14&catid=64&Itemid=122

The segments that have frequency less than or equals 4 will be split into two or more segments based on the positions of vowel nuclei and cluster. The algorithm is shown as Algorithm 1. A set of letters combination patterns can be seen in Thai Language article in Wikipedia¹⁰.

C. N-Gram Combination

In this stage, all initial segments from previous step will be measured the probability of two or more segments co-occur together. The function that measures the likelihood ratio of an occurrence of segments is applied. We only compute segment occurrence up to 4-grams based on our observation from Apache Lucene results. The example of n-gram combination can be seen in Fig. 3.

```

m = s1|s2|s3|s4|s5|s6
Pr(s1, s2)t = 0.124
    if Pr() < γ then do nothing
Pr(s2, s3)t = 0.457
    if Pr() ≥ γ then merge "s1" and "s2"
Pr(s2s3, s4)t = 0.004
    if Pr() < γ then do nothing
Pr(s4, s5)t = 0.354
    if Pr() ≥ γ then merge "s4" and "s5"
Pr(s4s5, s6)t = 0.259
    if Pr() ≥ γ then merge "s4s5" and "s6" when Pr(s4, s5)t < Pr(s4s5, s6)t
finally, m = s1|s2s3|s4s5|s6

```

Fig. 3. The example of n-gram combination

Algorithm 1 TokenSplitting(Token T)

LC is a set of last consonant letters
SL is a set of silence letters
CL is a set of clusters
TI is a set of tone indication
RegEx is a set of letters combination patterns
index is position that has been found using RegEX
match_list is a list of indexes

RegEX = [Vowel][Any Thai letters][TI*][LC*][SL*] or
[Any Thai letters][Vowel][TI*][LC*][SL*]

for Each RegEX do
 matcher = *pattern.matcher*(*T*)
 while *matcher* is FOUND **do**
 add *index* to *match_list*
 end while
end for

list_of_segments = *SplitToken*(*T*, *match_list*)
// *SplitToken* is function that split token *T* according to list of indexes.

return *list_of_segments*

The probability of an occurrence of segments in the corpus is computed as follow:

$$P(s_1, s_2 \in D) = \frac{|s_1s_2| \in D}{|s_1| \in D} \quad (1)$$

where D is the corpus, $|s_1s_2|$ is number of segment s_1 co-occur with s_2 in D , and $|s_1|$ is number of segment s_1 in D . By aggregating information in Twitter as local context and Thai Wikipedia as global context to compute the probability that a segment is a correct segment, the probability of an occurrence of segments s_1 and s_2 at time t can be computed as follow:

$$Pr(s_1, s_2)_t = \alpha P(s_1, s_2 \in TW_{t_0-t}) + (1 - \alpha) P(s_1, s_2 \in W) \quad (2)$$

where TW is the Twitter dataset from time t_0 to t and $t_0 < t$, W is the Thai Wikipedia dataset, α is a scaling of weights between Twitter and Wikipedia. For each message, we compute the probability of bi-grams, tri-grams and four-grams respectively. If the probability of bigram exist the merging threshold (γ), then we compute the probability of tri-grams and so on. However, if the probability of bi-grams greater than tri-grams, bi-grams will be selected as a correct segment in our approach. The algorithm of n-grams combination is shown as Algorithm 2.

Algorithm 2 NGramsCombination(list of segments S , time t)

for each segment $s \in S$ **do**
 new_segment = s_i
 prob1 = $Pr(s_i, s_{i+1})_t$
 if *prob1* > γ **then**
 new_segment = *merge*(s_i, s_{i+1})
 prob2 = $Pr(\text{new_segment}, s_{i+2})_t$
 if *prob2* > γ and *prob2* > *prob1* **then**
 new_segment = *merge*(*new_segment*, s_{i+2})
 prob3 = $Pr(\text{new_segment}, s_{i+3})_t$
 if *prob3* > γ and *prob3* > *prob2* **then**
 new_segment = *merge*(*new_segment*, s_{i+3})
 end if
 end if
 end if
 add *new_segment* to *list_of_segments*
end for
return *list_of_segments*

IV EXPERIMENTS AND EVALUATION

In order to find the best solution of micro-blog message segmentation, we manually label 900 messages from Twitter as a test dataset. The experiments are repeated 10 times and 200 messages are random for each round. The average results of the experiments are given in Table III. We evaluate our algorithm by using Precision, Recall and F1-score.

¹⁰ https://en.wikipedia.org/wiki/Thai_language

$$Precision = \frac{|T \cap C|}{|C|} \quad (3)$$

$$Recall = \frac{|T \cap C|}{|T|} \quad (4)$$

$$F1 - Score = 2 \times \frac{Precision \times Recall}{Precision + Recall} \quad (5)$$

where T is the true segments, C is system generated segments, |T| is number of segments in T, |C| is number of segments in C, and |T ∩ C| is number of segments that are in the same group in both T and C. We compare the performance of our approach with three baselines; ThaiAnalyzer approach by Apache Lucene, Using Thai Wikipedia as a global context approach, and Using previous Twitter messages as a local context approach.

To our best knowledge, this paper is the first to fully focus on Thai word segmentation in social networks. Three baselines are described as follows:

- Baseline 1 is an open-source library (i.e., ThaiAnalyzer) written in Java provides by Apache Lucene.
- Baseline 2 is an approach which use only Thai Wikipedia articles as a global context to compute the likelihood ratio of n-gram words. Thai Wikipedia data consist of 86,269 articles.
- Baseline 3 is an approach which use only previous one day Twitter data as a local context to calculate the likelihood ratio of n-gram words. Twitter dataset is crawled from the messages sent by users in Thailand, from the dates 17 April 2016 to 18 April 2016 with 175,294 messages. Re-tweet messages are excluded from our dataset.

According to our approach, we need to find the merging threshold (γ) and α which is a scaling of weights between Twitter and Wikipedia. In order to find the most suitable value for merging threshold (γ), we carry out segmentation on wikipedia and tweets from the dataset with different γ values. Our tests show that when $\gamma = 0.20$ it renders the best performance (as shown in Table II). Parameter α has been learned from statistics computed from the Twitter and Wikipedia datasets. Our experiments show that when $\alpha = 0.70$ it renders the best performance for incorporate between Twitter and Wikipedia (as shown in Table I).

We present the results of the experiments in Table III. The baseline 2 and 3 gave the best results when merging threshold (γ) are 0.45 and 0.50 respectively. It can be seen that our approach can effectively segment Thai word with a F1-score of 64.90% which

is significantly larger than the baselines. In other words, the incorporation between Twitter data and Thai Wikipedia can improve our segmentation performance.

V CONCLUSION

In this paper, an approach to automatically segment Thai words with time sensitivity over micro-blogs is developed. The goal of our approach is to effectively segment Thai word by utilizing real-time micro-blog messages and Wikipedia information. Our contributions are summarized as follows:

- An approach to segment Thai word in micro-blogs (i.e., Twitter) is presented.
- Local (i.e., Twitter) and global (i.e., Wikipedia) contexts are incorporated to improve the Thai segmentation.
- We evaluate our proposed approach with a real-world Twitter data posted by Thai-based users.

Our experiments are performed against three baseline approaches. The results show that our approach is effective in segmenting Thai words in social networks. In future work, Hybrid algorithms and Name Entity Recognition will be further studied to improve the performance of Thai word segmentation.

Table I Segmentation Results Of Our Approach With Different Weight Scale (α) And $\Gamma = 0.20$

α	Precision	Recall	F1-Score
0.5	60.00	70.01	64.62
0.6	60.83	69.51	64.88
0.7	60.90	69.46	64.90
0.8	60.65	69.62	64.82

Table II Segmentation Results Of Our Approach With Different Merging Thresholds (Γ) And $\alpha = 0.70$.

γ	Precision	Recall	F1-Score
5	60.38	62.06	61.21
10	61.22	67.08	64.02
15	60.93	68.52	64.50
20	60.90	69.46	64.90
25	60.31	69.63	64.63
30	59.47	69.29	64.00
35	59.74	70.10	64.51
40	59.57	70.28	64.48
45	59.37	70.36	64.40
50	59.06	70.44	64.25
55	59.01	70.49	64.24
60	59.00	70.53	64.25
65	58.90	70.51	64.18
70	58.87	70.54	64.18
75	58.81	70.50	64.13
80	58.79	70.49	64.11
85	58.81	70.52	64.13
90	58.72	70.46	64.06

Table Iii Segmentation Results Of Our Approach Against Baseline Methods.

Method	γ	α	Precision	Recall	F1-Score
Baseline 1 (Lucene)	-	-	58.63	69.30	63.52
Baseline 2 (Wiki)	0.45	-	59.07	70.92	64.46
Baseline 3 (Twitter)	0.30	-	60.52	68.68	64.34
Our Approach	0.20	0.70	60.90	69.46	64.90

REFERENCES

- Aroonmanakun, W. (2002). Collocation and thai word segmentation. In Proceedings of the 5th SNLP & 5th Oriental COCOSDA Workshop, pages 68–75. Citeseer.
- Aroonmanakun, W. et al. (2007). Thoughts on word and sentence segmentation in thai. In Proceedings of the Seventh Symposium on Natural language Processing, Pattaya, Thailand, December 13–15, pages 85–90.
- Haruechaiyasak, C. and Kongyoung, S. (2009). Tlex: Thai lexeme analyser based on the conditional random fields. In Proceedings of 8th International Symposium on Natural Language Processing.
- Haruechaiyasak, C., Kongyoung, S., and Dailey, M. (2008). A comparative study on thai word segmentation approaches. In Electrical Engineering/Electronics, Computer, Telecommunications and Information Technology, 2008. ECTI-CON 2008. 5th International Conference on, volume 1, pages 125–128. IEEE.
- Haruechaiyasak, C., Kongyoung, S., and Damrongrat, C. (2008b). Learnlexo: a machine-learning based word segmentation for indexing thai texts. In Proceedings of the 2nd ACM workshop on Improving non english web searching, pages 85–88. ACM.
- Haruechaiyasak, C., Sangkeetrakarn, C., Palingoon, P., Kongyoung, S., and Damrongrat, C. (2006). A collaborative framework for collecting thai unknown words from the web. In Proceedings of the COLING/ACL on Main conference poster sessions, pages 345–352. Association for Computational Linguistics.
- Kawtrakul, A., Thumkanon, C., Poovorawan, Y., Varasrai, P., and Suktarachan, M. (1997). Automatic thai unknown word recognition. In Proceedings of the Natural Language Processing Pacific Rim Symposium, volume 1997.
- Khankasikam, K. and Muansuwan, N. (2005). Thai word segmentation a lexical semantic approach. the Proceedings of the Tenth Machine Translation Summit, pages 331–338.
- Li, C., Sun, A., and Datta, A. (2012). Twevent: segment-based event detection from tweets. In 21st ACM International Conference on Information and Knowledge Management, CIKM'12, Maui, HI, USA, October 29 - November 02, 2012, pages 155–164.
- Limcharoen, P., Nattee, C., and Theeramunkong, T. (2009). Thai word segmentation based-on glr parsing technique and word n-gram model. In Eighth International Symposium on Natural Lanuage Processing.
- Mahatthanachai, C., Malaivongs, K., Tantranont, N., and Boonchieng, E. (2015). Development of thai word segmentation technique for solving problems with unknown words. In 2015 International Computer Science and Engineering Conference (ICSEC), pages 1–6. IEEE.
- Manning, C. D. and Schütze, H. (1999). Foundations of statistical natural language processing, volume 999. MIT Press.
- Mathioudakis, M. and Koudas, N. (2010). Twittermonitor: trend detection over the twitter stream. In Proceedings of the ACM SIGMOD International Conference on Management of Data, SIGMOD 2010, Indianapolis, Indiana, USA, June 6-10, 2010, pages 1155–1158.
- Meknavin, S., Charoenpornasawat, P., and Kijirikul, B. (1997). Feature-based thai word segmentation. Proceedings of of NLPRS.
- Palmer, D. D. (1997). A trainable rule-based algorithm for word segmentation. In Proceedings of the 35th Annual Meeting of the Association for Computational Linguistics and Eighth Conference of the European Chapter of the Association for Computational Linguistics, pages 321–328. Association for Computational Linguistics.
- Peng, F., Feng, F., and McCallum, A. (2004). Chinese segmentation and new word detection using conditional random fields. In Proceedings of the 20th International Conference on Computational Linguistics, COLING '04, Stroudsburg, PA, USA. Association for Computational Linguistics.
- Phaholpinyo, S. K. K. S. and Kosawat, K. (2011). Thai word segmentation verification tool. In Proceedings of the 2nd Workshop on South and Southeast Asian Natural Language Processing (WSSANLP 2011), page 16. Citeseer.
- Poowarawan, Y. (1986). Dictionary-based thai syllable separation. In Proceedings of the Ninth Electronics Engineering Conference, pages 409–418.
- Silva, J. F., Lopes, G. P., et al. (1999). A local maxima method and a fair dispersion normalization for extracting multiword units. In Proceedings of the 6th Meeting on the Mathematics of Language, volume 381.
- Sornlertlamvanich, V. (1993). Word segmentation for thai in machine translation system. Machine Translation, National Electronics and Computer Technology Center, Bangkok, pages 50–56.
- Theeramunkong, T. and Usanavasin, S. (2001). Nondictionary-based thai word segmentation using decision trees. In Proceedings of the first international conference on Human language technology research, pages 1–5. Association for Computational Linguistics.
- Unankard, S., Li, X., and Sharaf, M. A. (2015). Emerging event detection in social networks with location sensitivity. World Wide Web,18(5):1393–1417.

Using Graph Algorithm and Classification Technique for Finding an Optimal Bus Route in Time-Dependent Travel Times

Satjayod Deelertmongkolchai, Todsanai Chumwatana, and Choonhapong Thaiupathump

Rangsit University, Thailand, satjayod.deelertmongkolchai@th.rhenus.com, {todsanai.c; choonhapong}@rsu.ac.th

ABSTRACT

In the last decade, traffic jam has been regarded as a main problems for Bangkok. Most people selects a bus option for traveling because it is cheap and cover every area in Bangkok. However, they are suffering from the long hours in traffic jam especially in rush hour. They also cannot avoid this such jam as bus routes are fixed by Bangkok Mass Transit Authority (BMTA). This paper aims to propose a technique for finding an Optimal Bus Route in Time-Dependent Travel Times by using graph algorithm and data mining technique. The proposed technique is able to find a least spent travel time path between two nodes in a bus network with time-dependence. Graph algorithm is used to generate all possible paths to reveal the distances. Classification technique is then used to analysis traffic situation in different period of the time. By analysis traffic situation, date, time, week, month, location are used as a main factor for training process in classification technique. From the experimental studies, the proposed technique is able to show the best route from any given node to the final destination depending on the different period of the time. The proposed technique provides significant benefit for traveler to select the best bus route, which is short distance and fast, among generated routes

Keywords: Optimal bus route, Decision support system, Graph algorithm, Classification, Data mining.

I INTRODUCTION

At present, Bangkok Mass Transit System has various mode of transportation such as taxi, public bus, sky train (BTS) or subway (MRT) which an optimal transportation depends on people's final destination. A survey shows that public bus transportation is the most popular transportation mode in Bangkok because of its convenience to find a bus stop nearby and route coverage. Considering a fare, bus transportation has cheapest fare among others. The present fare for open-air bus is 6.5 - 9.00 THB and for air-conditioned bus is 11.0 - 26.0 THB. Due to the bus routes are fixed by Bangkok Mass Transit Authority (BMTA) which some routes pass

through traffic congested area, people have to face the unexpected time spent in travelling by public bus. In order to save the travelling time of the metropolitan, this paper aims to find an optimal bus route with least time spending by integration of two techniques which are graph algorithm and classification technique. As the result, the proposed technique provides significant benefit for traveler to select the best bus route, which is short distance and time saving, among the generated routes.

II RELATED WORK

Graph Algorithm (Alfred, 1983) is a main technique used to find an optimal route. The Graph Algorithm emphasizes a connection between two vertices which are called "Adjacent Vertices" that have connecting line between two vertices as shown in Figure 1.

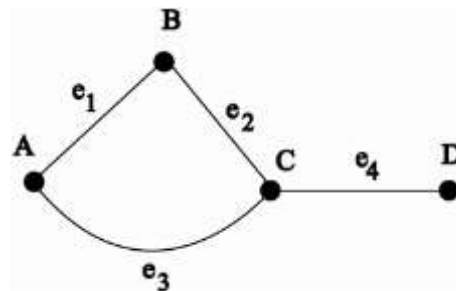

Figure 1. The Example of Graph

Description of the above Figure 1:

Vertex "A" and "B" are "Adjacent Vertices"

Vertex "A" and "C" are "Adjacent Vertices"

Vertex "B" and "C" are "Adjacent Vertices"

Vertex "C" and "D" are "Adjacent Vertices"

BUT Vertex "A" and "D" are not "Adjacent Vertices"

Vertex "B" and "D" are not "Adjacent Vertices"

From above definition, Graph Algorithm is used to find the shortest path from point to point by using Minimum Spanning Tree Algorithm or shortest path of the graph to find the shortest path which connects between each point.

Several researches are proposed for finding an optimal route by using Graph Algorithm such as

“Finding Safe and Optimal Route for Trip Itinerary”(Suwannapruek, 2011) which mentions a finding of the shortest path by using Graph Algorithm (Alfred, 1983) and “Considering Safety from an Severity Index of Junctions for Proposing Safe Route for Travelling” or “Finding Transport Routes for Bulk Goods by using Dynamic Programming” (Manee-ngam, 2013) which mentions mathematical techniques used for finding transport routes that are minimum total cost of transport by comparing with an original transport which uses the shortest path, the result illustrates that the total cost of transport can be reduced to 17% from the original path selection method.

In year 2014, the research “An Application of the Travelling Salesman Problem Case Study: Routing for Streetcar Tour of the Chiang Rai Municipality” (Seksan, 2014) proposes a finding of shortest path by means of linear programming in comparison with an existing route which the electric car tour runs through all the tourist locations, the experimental result finds a shorter path to 9.075% in comparison with an existing route and proposes a factor of traffic condition for the best result for route management. Furthermore, classification theory is applied to this research by using K-NN Classification method (Pang-Ning, 2005) which classifies data by measuring the distance between predicted data and nearby data that defined the amount as “K”, the result from prediction shows a group of most data which is close to the “K” amount. A method of measuring a distance according to an equation below:

$$D_{Euclidean} = \sqrt{(F1_{test} - F1_{train})^2 + (F2_{test} - F2_{train})^2}$$

This method is applied to several researches , for example “A Comparison of Credit Card Approval Prediction Efficiency between Four Classification Methods of Thai Commercial Banks” (Sinsomboonthong, 2014) which proposes to compare an efficiency of each algorithm (Ian, 2005), for example : K-NN, Decision Tree, Neural Network and Support Vector Machine. As a result, a neural network method shows the best accuracy at 70.37% in comparison with an efficiency of other algorithms.

III USING GRAPH ALGORITHM AND CLASSIFICATION TECHNIQUE FOR FINDING AN OPTIMAL BUS ROUTE IN TIME DEPENDENT TRAVEL TIMES

This research proposes an integrated technique between Graph Algorithm and Classification

Technique for finding an optimal bus route. A working process is shown in Figure 2

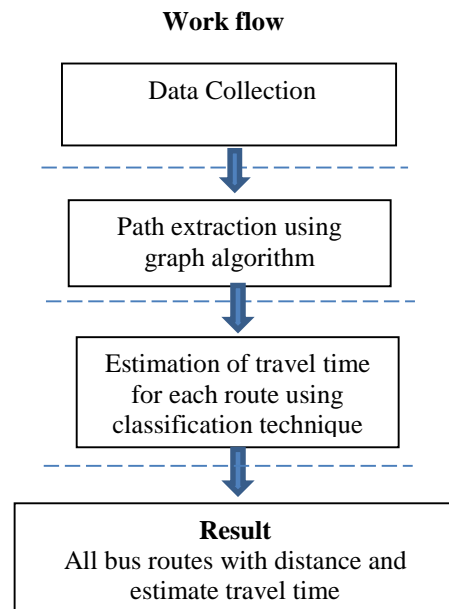

Figure 2. Process of the proposed Technique

From Figure 2, a proposed working technique consists of two main steps which are A) using graph algorithm for finding route from place to place and B) using classification technique for bus route time calculation by predicting a traffic condition from traffic density data. The result from the proposed technique is an optimal bus route from place to place which takes less time and short path. The detail of each processes will be described as following:

A. Using graph algorithm for finding route from place to place

This step begins with the data collection from a distance of each bus stop regarding to a fare table of a bus which passes the studied route as shown in Figure 3.

Bus Route No.95 Rangsit - Bang Ko Pi

Distance (KM)	Station	Fares (Baht)
0	0	
2	1	
4	2	
6	3	
8	4	
10	5	
12	6	
14	7	
16	8	
18	9	
20	10	
22	11	
24	12	
26	13	
28	14	
30	15	

Station	15	16	17	18	19	20	21	22	23	24	25	26	27	28	29	30
Rangsit																
Ru Chokchai																
Yehowadi Road																
Between Thantaram Village																
Dong Muang Airport																
Between Air Force Tank Farm																
Lak Si																
Lak Si Victory																
Between Thai Army Golf Course																
Kan Kuy Ha-Ravindra Flat																
Thai Army Village																
Kid Si Market																
Ummainivet Village																
Phattakorn Village																
Happyland Crossroad																
Bang Ko Pi																

Figure 3. Fare of bus No.95

From Figure 3. the above fare table is used for defining the places on map (refer to: <https://map.longdo.com/>) and finding a distance of each bus stop in order to collect data of a distance and a bus which passes each place as shown in Figure 4 and Table 1.

source	Destination	Distance (m)	Bus number
AA	BB	900	29,34,39,59,95n,185,503,510,520,522
BB	CC	1500	29,59,95n,510
CC	DD	3100	29,59,95n,510
DD	EE	1900	29,59,95n,510
EE	FF	2600	29,59,95n,510
FF	GG	2800	29,510
GG	HH	3100	29,510
HH	II	1700	29,510
II	JJ	1900	29,510
JJ	KK	2400	29,510
KK	LL	3300	34,39,59,503
LL	MM	600	34,39,59,503
MM	NN	1600	34,39,59,185,503
NN	OO	2200	34,39,59,185,503,522
NN	HH	1600	522
OO	PP	4500	34,39,59,185,503,522

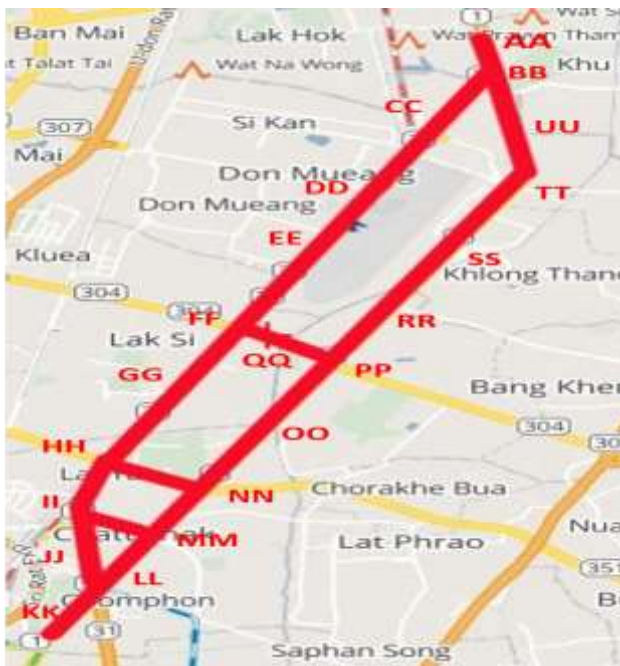

Figure 4. Points Of Bus Stops On A Map

Table 1. List of bus number pass from source to destination

From the above data, a distance between source to destination can be calculated by distributing all possible routes from a graph and calculating total distance from place to place as shown in Figure 5 below which KK is defined to be a source and OO is defined to be a destination and a total distance of each route is also presented.

Route 1	KK-> LL-> MM-> NN-> OO->	7700 m.
Route 2	KK-> JJ-> II-> HH-> NN-> OO->	9800 m.
Route 3	KK-> JJ-> II-> HH-> GG-> FF-> QQ-> PP-> OO->	18250 m.
Route 4	KK-> JJ-> II-> HH-> GG-> FF-> EE-> DD-> CC-> BB-> UU-> TT-> SS-> RR-> PP-> OO->	35300 m.

Figure 5. Showing all routes and total distance of each route from KK to OO

The routes and total distance of each route are used to calculate traffic density of each route in order to predict travelling time as described below.

B. Using Classification Technique for Bus Route Time Calculation by Predicting a Traffic Condition from Traffic Density Data

This step begins with a collection of online traffic condition data on map (refer to: <https://map.longdo.com/>) in each period of time, starting from 6.00 am. to 8.00 pm (working hour) as shown some example in Figure 6. With data collection of retroactive date and time, this is applied to training process and leading to predictive ability of future traffic condition.

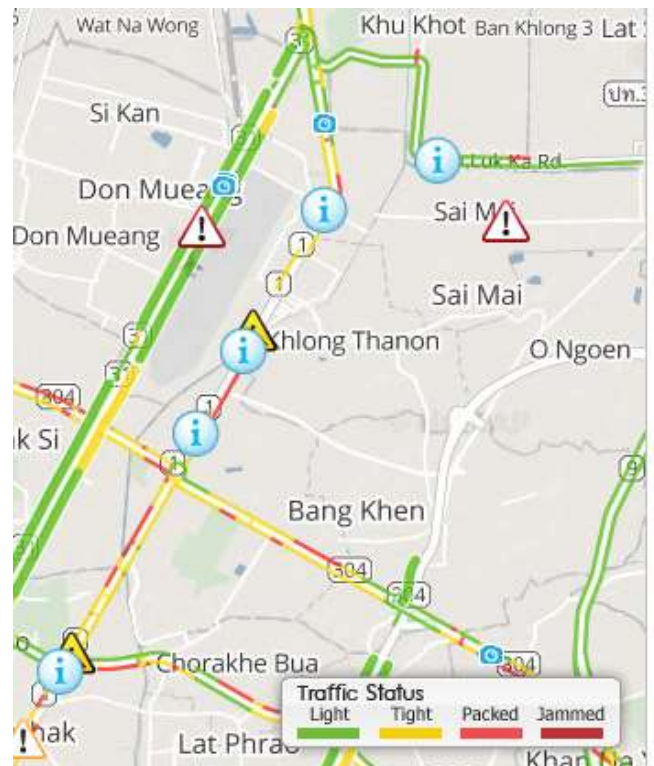

Figure 6. Online Traffic Condition

From the above figure, traffic condition is classified to four levels as follows (refer to: www.traffic.longdo.com):

- Green line is used to define a good traffic
- Yellow line is used to define a traffic congestion
- Orange line is used to define a traffic jam

- Red line is used to define a really bad traffic

These traffic conditions are applied as the factor of travelling time calculation on each route which is extracted in the first step as shown in Figure 5. In this paper, K-NN Classification Technique (Ian, 2005) is applied to traffic condition predictive analytic by calculating from a retroactive data as follows:

Source	AA	UU	MON	SUN	06.00-07.00	19.00-20.00	WEEK1	WEEK4	STATUS
AA	N	N	Y	N	Y	N	Y	N	GREEN
AA	N	N	Y	N	N	N	Y	N	GREEN
AA	N	N	Y	N	N	Y	Y	N	YELLOW
BB	N	N	Y	N	Y	N	Y	N	GREEN
BB	N	N	Y	N	N	N	Y	N	GREEN
CC	N	N	Y	N	N	N	Y	N	GREEN
CC	N	N	Y	N	N	N	Y	N	GREEN
DD	N	N	Y	N	N	N	Y	N	YELLOW
DD	N	N	Y	N	N	N	Y	N	YELLOW
DD	N	N	Y	N	N	Y	Y	N	GREEN
FF	N	N	Y	N	Y	N	Y	N	ORANGE
GG	N	N	Y	N	N	N	Y	N	GREEN
GG	N	N	Y	N	N	N	Y	N	GREEN

Figure 7. Sample Of Data Collection Which Is Used For Analysis

When collecting the results from above two steps, it founds that the techniques show a result of all bus routes from a source to a destination, including a distance and an average time for travelling as shown in Table 2.

Table 2. Example Of Result From The Propose Technique

Route	Bus stop station in the each place										Distance (m)	Total Times (Min)	Suggestion For Travelling	
	AA	UU	MON	SUN	06.00-07.00	19.00-20.00	WEEK1	WEEK4	STATUS	Source - Destination			Bus Number	
Route 1	KK	LL	MM	NN	OO						7700	25.30	KK-OO	34,39,59,303
Route 2	KK	JJ	II	HH	GG						9800	33.00	KK-HH	29,512
Route 3	KK	JJ	II	HH	GG	FF	QQ	PP	OO		18230	40.58	KK-PP	29,310
Route 4	KK	JJ	II	HH	GG	FF	EE	DD	CC	BB	35300	84.20	KK-BB	29,512
													BB-UU	34,39,303

From Table 2, the result of the proposed technique can supports people to make a smart decision when travelling by bus. The decision can be made into different ways. For example, some people select long distance but spend faster time while the others may select short distance but spend long time. The decision is depending on individual acceptable and situation.

IV EXPERIMENTAL STUDIES

This section describes an experiment for finding the optimal Bus Route with travelling time by using efficiency technique which is proposed in this research. Example of an experiment for finding an optimal bus route starts from KK (Mochit Skytrain Station) and finishes at OO (Bangbua Temple). An experiment of the travel is made on Wednesday of

week 4 of a month from 6.00 pm. to 7.00 pm and the results show as follows:

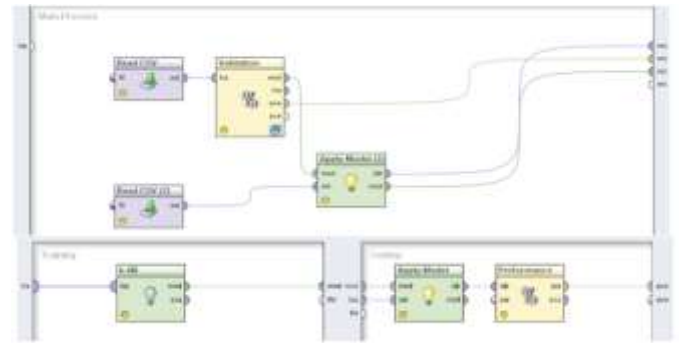

Route 1	KK-> LL-> MM-> NN-> OO->	7700 m.
Route 2	KK-> JJ-> II-> HH-> NN-> OO->	9800 m.
Route 3	KK-> JJ-> II-> HH-> GG-> FF-> QQ-> PP-> OO->	18250 m.
Route 4	KK-> JJ-> II-> HH-> GG-> FF-> EE-> DD-> CC->	
	BB-> UU-> TT-> SS-> RR-> PP-> OO->	35300 m.

Figure 8. Result of an Applicable Route for Travelling

The next section is a prediction of traffic condition by using Rapid Minor Software for testing as shown in Figure 9.

Figure 9. Experimental Analysis on Rapid Minor Software

From this experiment which is made by collecting data for 2 months, a result shows as follows:

Table 3. Data collection for 2 months

Source	Prediction	Con G	Con Y	Con Orj	Con R	AA	UU	WED	T	18.00-19.00	WEEK1
AA	YELLOW	0	1	0	0	N	N	Y	Y	Y	Y
BB	YELLOW	0	1	0	0	N	N	Y	Y	Y	Y
CC	GREEN	1	0	0	0	N	N	Y	Y	Y	Y
DD	GREEN	1	0	0	0	N	N	Y	Y	Y	Y
EE	YELLOW	0	1	0	0	N	N	Y	Y	Y	Y
FF	GREEN	1	0	0	0	N	N	Y	Y	Y	Y
GG	GREEN	1	0	0	0	N	N	Y	Y	Y	Y
HH	ORANGE	0	0	1	0	N	N	Y	Y	Y	Y
II	YELLOW	0	1	0	0	N	N	Y	Y	Y	Y
JJ	ORANGE	0	0	1	0	N	N	Y	Y	Y	Y
KK	YELLOW	0	1	0	0	N	N	Y	Y	Y	Y
LL	YELLOW	0	1	0	0	N	N	Y	Y	Y	Y
MM	YELLOW	0	1	0	0	N	N	Y	Y	Y	Y
NN	ORANGE	0	0	1	0	N	N	Y	Y	Y	Y
OO	ORANGE	0	0	1	0	N	N	Y	Y	Y	Y
PP	ORANGE	0	0	1	0	N	N	Y	Y	Y	Y
QQ	ORANGE	0	0	1	0	N	N	Y	Y	Y	Y

From Figure 8 and Table 3, the results of two steps is used for calculating an average time by calculating average speed from www.traffic.longdo.com as shown in Figure 10.

Green	Average Speed 40 Km / Hour
Yellow	Average Speed 20 Km / Hour
Orange	Average Speed 15 Km / Hour
Red	Average Speed 10 Km / Hour

Figure 10. Average Speed According To The Highlight

The average speed in different time period shown in the above figure is used to find a time of each route, a calculation result is shown in Table 4.

Table 4. A Prediction Result In The Experimental Route

Source	Destination	Distance (m)	Bus Number	Prediction	Total Time (min)
KK Mochit Skytrain Station	LL Satriyanarabangkien School	3300	34,39,39,303	yellow	3.9
LL Satriyanarabangkien School	MM Ratchayothin Intersection	600	34,39,39,303	yellow	2.4
MM Ratchayothin Intersection	NN Kasetsart Intersection (Phahon Rd.)	3000	34,39,39,303,303	orange	6.4
NN Kasetsart Intersection (Phahon Rd.)	OO Bangbua Temple	2200	34,39,39,303,303,311	yellow	6.6
KK Mochit Skytrain Station	LL Ho Wang School	3400	29,530	orange	3.0
LL Ho Wang School	II Mass Newspaper	2900	29,530	yellow	2.85
II Mass Newspaper	MM Kasetsart Intersection (Vithavadi Rd.)	1700	29,530	orange	2.53
MM Kasetsart Intersection (Vithavadi Rd.)	NN Kasetsart Intersection (Phahon Rd.)	3600	511	orange	6.4
NN Kasetsart Intersection (Vithavadi Rd.)	OO Police Academy School	1100	29,530	green	3.3
OO Police Academy School	PP Lak si Vithavadi Rd.	3600	29,530	green	4.2
PP Lak si Vithavadi Rd.	QQ Phra Nakham Rajabhat University	300	39,956	orange	3.4
QQ Phra Nakham Rajabhat University	PP Laksi Monument	800	39,956	green	1.25
PP Laksi Monument	OO Bangbua Temple	4500	34,39,39,303,303,311	yellow	13.5
PP Lak si Vithavadi Rd.	EE Bangkok Aviation Fuel Services	3600	29,59,956,530	yellow	7.8
EE Bangkok Aviation Fuel Services	OO Don Mueang International Airport	2900	29,59,956,530	yellow	2.85
OO Don Mueang International Airport	CC Thasin Than Village	1100	29,59,956,530	green	4.65
CC Thasin Than Village	BB Vithavadi Rangsit Intersection	2500	29,59,956,530	yellow	4.5
BB Vithavadi Rangsit Intersection	UU Phahon Yothin 62	3000	34,39,39,303,303,311	yellow	4.8
UU Phahon Yothin 62	TT Royal Thai Air Force Academy	2200	34,39,39,303,303,311	yellow	6.6
TT Royal Thai Air Force Academy	SS Bhumibol Adulyadej Hospital	3000	34,39,39,303,303,311	yellow	6.4
SS Bhumibol Adulyadej Hospital	RR Ying Charoen Market	2600	34,39,39,303,303,311	orange	6.4
RR Ying Charoen Market	PP Laksi Monument	3000	34,39,39,303,303,311	green	4.2

An above result can be summarized an experiment for finding route which starts from KK (Mochit Skytrain Station) and finishes at OO (Bangbua Temple), the result is presented in Table 5 and Figure 11.

Table 5. An Experimental Result Of A Suggestion For Travelling By Bus Starting From KK (Mochit Skytrain Station) And Finishing At OO (Bangbua Temple)

Route	Bus stop station in the next place																Distance (m)	Total Times (Min)	Suggestion For Travelling		
	KK	LL	MM	NN	OO	PP	QQ	RR	SS	TT	UU	VV	WW	XX	YY	ZZ			Source - Destination	Bus Number	
Route 1	KK	LL	MM <td>NN</td> <td>OO</td> <td></td> <td></td> <td></td> <td></td> <td></td> <td></td> <td></td> <td></td> <td></td> <td></td> <td></td> <td>7700</td> <td>25.30</td> <td>KK - OO</td> <td>34,39,39,303</td>	NN	OO												7700	25.30	KK - OO	34,39,39,303	
Route 2	KK	LL	II	MM	NN	OO											8800	23.00	KK - II	29,530	
																			II - OO	511	
Route 3	KK	LL	II	MM	NN	OO	PP	QQ	RR	SS	TT	UU	VV	WW	XX	YY	ZZ	18230	46.68	KK - PP	29,530
																			PP - OO	59	
Route 4	KK	LL	II	MM	NN	OO	PP	QQ	RR	SS	TT	UU	VV	WW	XX	YY	ZZ	35300	84.27	KK - RR	29,530
																			RR - UU	34,39,303	

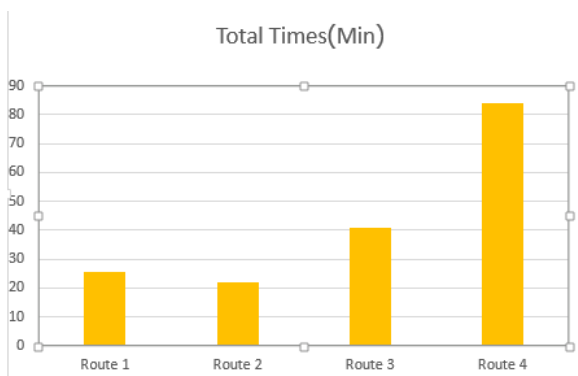

Figure 11. Time Spent Travelling On Each Route

From graph shown in Figure 11, an experiment for finding all applicable routes shows four routes which

the shortest-distance route is route 1 and the longest-distance route is route 4. When a factor of traffic condition prediction is integrated to this experiment, the result shows that the distance of route 1 is 7,700 meters long that takes 25.30 minutes time for travelling, whereas the distance of route 2 is 9,800 meters long but it takes only 22 minutes time for travelling. As a result, it can be assumed that route 2 would be an optimal bus route for travelling from KK to OO place.

V CONCLUSION

This research proposes the integrated techniques between 2 theories in order to provide an optimal bus route by using Graph Algorithm to generate the possible bus routes and integrates a classification technique to this research by using K-NN Algorithm for traffic condition prediction. From the experimental study, the result of an integration of 2 theories reveals the best result which is an optimal bus route. In the comparison between route 1 and route 2, the result shows that although route 1 is the shortest distance route but takes 25.30 minutes for travelling, on the other hand, route 2 is 2,100 meters longer than route 1 but takes only 22 minutes for travelling. Hence, this research provide significant benefit for traveler to find the optimal bus route in time-dependent travel times in Bangkok.

REFERENCES

Alfred, V. Aho, J. Hopcroft, E and Jeffrey U. (1983). Data Structures and Algorithms (1st ed.). Addison-Wesley Longman Publishing Co., Boston, MA, USA.

Ian, H. Witten and Eibe, F. (2005). Data Mining: Practical Machine Learning Tools and Techniques, Second Edition (Morgan Kaufmann Series in Data Management Systems). Morgan Kaufmann Publishers Inc., San Francisco, CA, USA.

Manee-ngam, A. and Sripathamswat, K. (2013). Path Selection for Bulk Cargo Transportation using Dynamic Programming. vol. 1, pp. 52-62, 2013.

Pang-Ning, T. Michael, S. and Vipin, K. (2005). Introduction to Data Mining, (First Edition). Addison-Wesley Longman Publishing Co., Inc., Boston, MA, USA.

Seksan, W. (2014). An Application of the Travelling Salesman Problem Case Study: Routing for Streetcar Tour of the Chiang Rai Municipality. Industrial Technology Lampang Rajabhat University Journal., vol. 2, pp. 85-97.

Sinsomboonthong, S. (2014). A Comparison of Credit Card Approval Prediction Efficiency between Four Classification Methods of Thai Commercial Banks. Journal of Industrial Education.

Suwannapruek ,T. (2011). The development of an optimal safe path for trip planning. IEEE Transactions on Communications, pp. 105-111

Filtering Spam Mail in Non-Segmented Languages Using Hybrid Approach: the Integration of Stopword Removal, N-gram Extraction and Classification Techniques

Ployphailin Khumsong, Todsanai Chumwatana, and Supanit Augsirikul

Rangsit University, Thailand, {ploypailin.k54; todsanai.c; supanit.a}@rsu.ac.th

ABSTRACT

Junk mail or spam mail has been regarded as a major problem in today's world. The spam mail can lead to cybercrime that impacts all individuals and organization. Many people and businesses seek for spam mail prevention technique in order to protect their own data and computer system. The spam mails normally contain advertise products or services contents and also conveys viruses, malwares, spywares and so forth. Many people thought spam mails do not cause any damage. In fact, the spam mails made a management cost increased and resources will be used ineffectively. Therefore, verifying and filtering spam mails need to be taken into consideration. The objective of this paper is to introduce the hybrid approach, which combines three techniques including stop-word removal, n-gram extraction and data classification, for filtering spam emails and simplifies system development. The proposed hybrid approach can be widely applied for all different languages due to being language independent technique. To examine the approach, CSDMC2010 spam mail corpus comprising of 198 common emails, 202 spam mails, and 10 selective emails were used in experimental study. The results showed that the proposed technique enabled to monitor whether the email is spam with 93.2% accuracy. Hence, this hybrid approach could provide benefits for all users and organization to decrease the computer risk.

Keywords: Spam mail, N-gram extraction, Classification, Stop-word removal, Non-segmented languages

I INTRODUCTION

In Thailand, the Internet recently plays a significant role which makes the communication easier for people in all areas. Electronic mails or e-mail serve as the popular communication channel which widely used due to cost and time saving. More importantly, the e-mail is an online service and unlimited that can be sent to multi people in different places at a time.

Regarding the advantages, the email has become a primary way for online communication among the Internet users (Statistics and facts of email marketing, 2013) With the rapid growth and various benefits of the email, some groups of people make an effort to

earn their income by using email containing soliciting message to advertise, promote or selling their products and services. This potential threat is known as "Spam Mail". The spam mail or unsolicited message email causes the interruption to any receiver in which they are offended their privacy and waste their time to eliminate those spam mails. The spam mails steadily increase on the Internet because it is instant and very cost-effective medium (Puckdeewongs, 2003). Consequently, the spam mail is used for money purpose. Furthermore, the large growth of spam mail also impacts to all people and organization in the aspect of computer risk since spam mail embeds not only persuasive texts but also viruses, malwares, spywares, and so forth. These are harmful to all users including individuals, organizations and a group of agencies.

In general, the spam mail are basically prevented or detected by examining words which are comprised in any sections of emails such as the title or the content (Tubsee, 2010). Words used in the email content are separated and brought to investigate the characteristic of spam mail. Nevertheless, procedures in separating words of each language are different, for example, English words are separated by white space. In contrast to English language, many Asian languages (e.g. Chinese, Japanese, Thai and Korean) are written without spaces. Thus, the traditional technique can be only applied with English languages. Regarding to the limitation, n-gram has become more important technique for separating words from email content because it can be used with all different languages without considering the meaning of words. Moreover, the study of Stop-word removal for more accuracy in filtering the spam mails should be concerned. Based on the survey, the email both normal and spam mails mainly composed of Stop-word approximately 30 to 50% of the content in many languages. The set of Stop-word is normally shared by most emails which make the accuracy of distinguishing and filtering the spam mails is lower. Hence, this research aims to propose the hybrid approach integrating three techniques: Stop-word Removal, N-gram and Data Classification, for better categorization and filtering spam mails.

II RELATED WORKS

Spam mail is a term of unsolicited commercial message which has been sent to numerous recipients without their permission or reception (Yusuk, 2013). Those spam mails are unwanted mail which encompasses with product, services, advertisement, online gamble contents (Rojkangsadan, 2016). In traditional way, screening the spam mails can be done through data classification technique, which previous data are collected and brought to train the system and then to establish a new model for testing. The classification technique consists of three main procedures: 1) creating a new model by analyzing the previous data with a variety of data classification techniques, 2) testing the efficiency of the build model, and 3) applying the model for screening new upcoming data (Pacharawongsakda, 2014).

Before classifying the data, information extraction (IE) process is primarily used for classifying the proper information. Many algorithms may be adopted in the information extraction in order to enhance computer system for greater comprehension on any document, texts, and data (Mansamut, 2010). Another technique is to employ Natural Language Processing (NLP), the artificial intelligence that enables a computer program to understand intended meaning of any human languages. Nevertheless, the diversity of human speech reflects various kinds of language difficulties such as ambiguity, pronouns, reference and ellipsis. As a result, the classification of text documents can be divided into two main techniques: language dependent and language independent (Todsanai, 2014).

In the language dependent approach, there are several techniques proposed to split non-segmented texts such as Chinese (Kwok), Japanese (Croft, 1993), Korea (Ahn, 1996) and Thai (Smith, 2001) into term tokens. A word segmentation technique is usually required to extract a bag of words before they can be used in classification process. This technique usually rely on language analysis or on the use of dictionary. The preparation of such method is very time consuming. Therefore, word segmentation has become a challenging task in Natural Language Processing (NLP) for many languages.

Apart from language dependent technique, there is other technique, called n-gram technique, which is language-independent (Adams, 1991). This technique is a language-independent approach which has been adapted in word delimitation process. n-gram is a sequence of items which typically collected from either spoken and written texts. The n-gram model word type provides more efficient to establish "Language Statistic Model" and to retrieve any information without language dependency (Majumder, 2002). For instance, the analysis of a word

'university' by bi-grams resulted as : un, ni, iv, ve, er, rs, si, it, ty, y_, using ' _ ' for space.

Both language dependent and independent approaches have been applied in several previous studies in the area of document classification in multi-languages. The study of Majumder investigated five groups of Indian language adhering to Algorithm theory proposed by Cavnar (Majumder, 2002). The researchers selected a set of 100 documents from five different Indian languages for creating n-gram profiles and examining the shortest space. Their findings showed that using alphabets and words building n-gram profiles offer positive results in both cases.

Another study is done by Mansur (Mansur, 2006) employing n-Gram Algorithm to categorize Bangla in Prothom-Alo newspapers which was published for a year. The overall results revealed that 2-gram or 3-gram could perform as the most proper methods for data classification. Furthermore, Zhihua adopted text representative and data selection techniques to classify data in Chinese language (Zhihua, 2009). They examined n-grams for three main purposes: 1) to compare the effectiveness on performance of data selection features, 2) to compare the sparseness, and 3) to compare the ability among three weight methods.

The data from Chinese corpus TanCorpV1.0 (over 14,000 texts divided into 12 classes) were used as the source of data in their study. Their research findings are detailed as follows: 1) by using less than 3000 features, the n-gram frequency basically provides better outcomes rather than those selected by text frequency (absolute or relative). Relative frequency results reflect more negative consequences than absolute frequency. In the cause of using greater than 3000 features, both absolute and relative frequency results contained much similarity, 2) the selective method using n-gram frequency caused a dense of "text feature" matrix, which was more than the relative frequency, 3) the n-gram frequency selection generated the feature which carried less correlation than those selected in the text frequency, and 4) text representation at TF weight contained similar performance to those text using $tf \cdot idf$, in which both methods had greater capability than 0/1 logical weight.

III FILTERING SPAM MAIL IN NON-SEGMENTED LANGUAGE USING HYBRID APPROACH: THE INTREGATION OF STOP-WORD REMOVAL, N-GRAM EXTRACTION AND CLASSIFICATION TECHNIQUES

This section describes five procedures of spam mail filtration by applying the integration of three techniques: Stop-word Removal, N-gram extraction and classification techniques. Workflow of the proposed technique is illustrated in Figure 1.

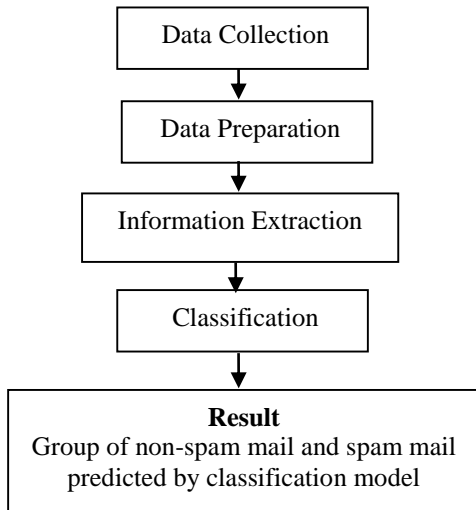

Figure 1. Workflow of the proposed technique.

From Figure 1, the processes in screening or filtering spam mails are divided into four steps including data collection, data preparation, information extraction and classification. These four steps comprise of distinct function as given below.

A. Data Collection

For data collection (Spam email datasets, 2010), all data was gathered from CSDMC2010 SPAM corpus by selecting the content of emails and used to experiment spam mail filtering system. 410 sets of information were brought and grouped into three folders: 1) 198 normal electronic mails, 2) 202 junk mails or spam mails, and 3) 10 selected mails opened with outlook program for sighting all content in the mails.

B. Data Preparation

The data preparation is the second procedure which aims to select the information from email content and to convert the data. Before information extraction, '.eml' files were converted into '.txt' or text document files for being used in the other steps. The data preparation stage is presented in Figure 2 and 3.

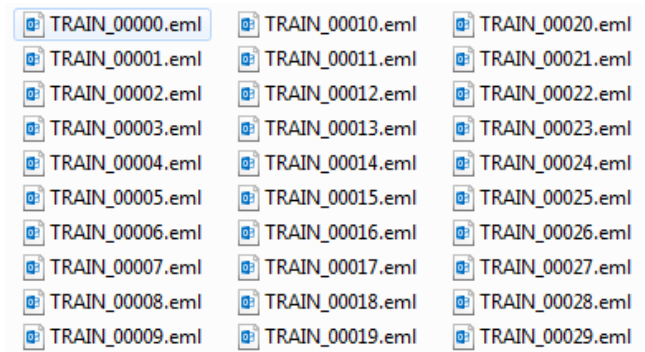

Figure 2. Collection of Files Used in the Study.

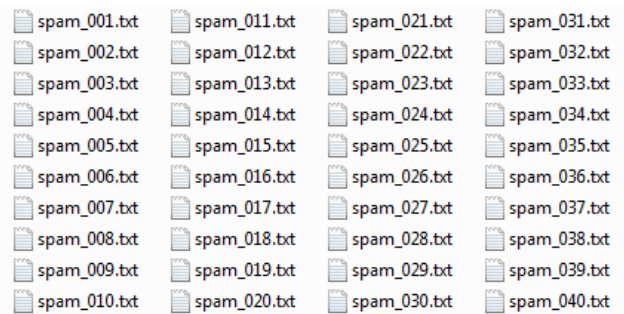

Figure 3. Collection of Converted Files.

C. Information Extraction and Natural Language Processing

At this recent stage, two methods including Stop-word Removal and n-gram Extraction were then performed. Stop-word Removal method refers to words or vocabularies which frequently appear in all types of written documents, but those words are unable to represent the focal meaning of the message such as a, an, the, and, about, is, am, are in English language as shown in figure 4. Typically, many languages in the world have their own stop word list which appears approximately 30 to 50% of the content. The frequent occurrence of those stop words would make most email are similar to each other which makes it difficult in distinguishing the spam mail from non-spam mails. This is because most emails share the same stop words in emails. Consequently, these stop words should be excluded from the email before information extraction can be performed.

A	CANNOT	INTO	OUR	THUS
ABOUT	CO	IS	OURS	TO
ABOVE	COULD	IT	OURSELVES	TOGETHER
ACROSS	DOWN	ITS	OUT	TOO
AFTER	DURING	ITSELF	OVER	TOWARD
AFTERWARDS	EACH	LAST	OWN	TOWARDS
AGAIN	EG	LATTER	PER	UNDER
AGAINST	EITHER	LATTERLY	PERHAPS	UNTIL
ALL	ELSE	LEAST	RATHER	UP
ALMOST	ELSEWHERE	LESS	SAME	UPON
ALONE	ENOUGH	LTD	SEEM	US
ALONG	ETC	MANY	SEEMED	VERY
ALREADY	EVEN	MAY	SEEKING	VIA
ALSO	EVER	ME	SEEMS	WAS
ALTHOUGH	EVERY	MEANWHILE	SEVERAL	WE

Figure 4. Example of Stop Words in English.

At this step, stop words are eliminated by creating Hash Table for all stop words and compare with email content in the collection. After that, stop words shown in the email were then deleted; only important content remains in the document. The next step is extracting n-gram from the emails. All emails without stop words were processed in the information extraction by using n-gram technique. In this paper, 2-gram, 3-gram, 4-gram and 5-gram were used as a dimension of gram in information extraction process which will be described in the following.

Assume that email d consists of a string s of characters a_1, a_2, \dots, a_N . An n-gram term is a substring of n overlap or non-overlap successive characters extracted from the string. Extracting a set of n-gram terms from the email d can be done by using the 1-sliding technique. Therefore, the i th n-gram term extracted from email d is the substring $a_i, a_{i+1}, \dots, a_{i+n}$. Table 1 shows 2-gram, 3-gram, 4-gram, 5-gram overlap sequence of the email d containing the string s 'you won'

Table 1. Samples of 2-gram, 3-gram, 4-gram, 5-gram of string s 'you won'.

n-gram	List of n-gram terms
2-gram terms	yo, ou, u_, _w, wo, on
3-gram terms	you, ou_, u_w, _wo, won
4-gram terms	you_, ou_w, u_wo, _won
5-gram terms	you_w, ou_wo, u_won

After dividing terms with n difference, the researcher produced the model for information processing and predicting types of emails in the next procedures.

The different size of n (2-5) was used to assess the performance and to investigate the proportion of n which reflects the most effective results.

D. Data Classification

The research was conducted using data mining techniques which includes Decision Tree, Naïve Bayes, K-NN and SVM with the same set of data. The results of SVM technique is appropriate for the data sets and the highest performance. Therefore, SVM technique is used as a model applied in this research. In this step, the SVM model were constructed from training data method. After extracting n-gram terms from emails, the SVM model was tested with a set of testing data for assessing the accuracy of the model. The researcher experimented the model three rounds with the specific different random seed starting from 500, 1000, and 1500. In addition, the comparison of model performance with different size of n from 2 to 5 was assessed. The average or mean of various n -gram performance are presented in Table 2.

Table 2. Percentage of accuracy for different grams.

Random Seed	2-gram	3-gram	4-gram	5-gram
500	75.06	90.93	91.18	93.2
1000	74.81	90.93	91.18	93.2
1500	76.07	92.19	91.18	93.2
Average	75.31	91.35	91.18	93.2

From table 2, result shows the percentage of accuracy of predicting or categorizing whether the sample emails are normal or spam mails. The accuracy of the analysis would be monitored. The experimental study and result will be described in detail in next section.

IV EXPERIMENTAL STUDY

Set of input emails used in this paper were collected from CSDMC2010 SPAM Corpus (from: <http://csmining.org/index.php/spam-email-datasets-.html>). The researcher gathered 410 data which were separated into three sets: 198 normal mails, 202 spam mails, and 10 testing emails. These email will be sent to Stop-word removal and Information Extraction processes. Then the SVM model were created and learn from the data set by using 10-Fold Cross Validation method. The operator used in training process is shown in Figure 5. Moreover, the performance of the SVM model and the build SVM model are presented in Table 3 and Figure 6.

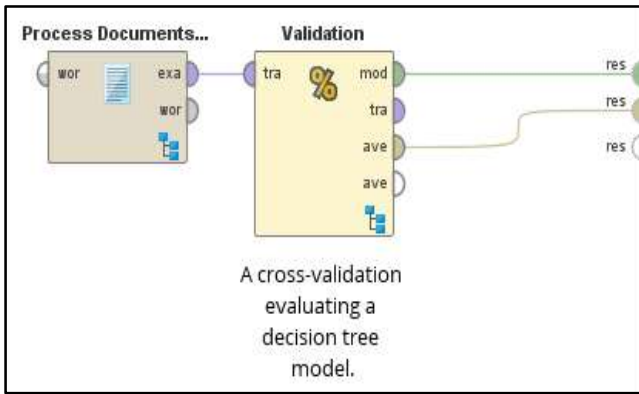

Figure 5. Operator Used in Training Data Method.

Table 3. Performance of the SVM Model.

accuracy: 93.20% +/- 2.28% (mikro: 93.20%)

	True spam	True nospam	Class precision
Pred.spam	190	18	91.35%
Pred. nospam	9	180	95.24%
Class recall	95.48%	90.91%	

R..	label	metadata_file	abase	abili	able	about	above	achin
197	spam	spam_200.txt	0	0	0	0	0	0
198	spam	spam_201.txt	0	0	0	0	0	0
199	spam	spam_202.txt	0	0	0	0	0	0
200	nospam	nospam_001.txt	0.103	0	0	0	0	0
201	nospam	nospam_002.txt	0	0	0	0.061	0	0
202	nospam	nospam_003.txt	0	0	0	0.037	0	0.229

Figure 6. Sample of the Build SVM Model.

Once building and evaluating the efficiency of the SVM model is completed, it is then used to test with testing email as shown in Figure 7. The results of this experiment are presented in Table 4.

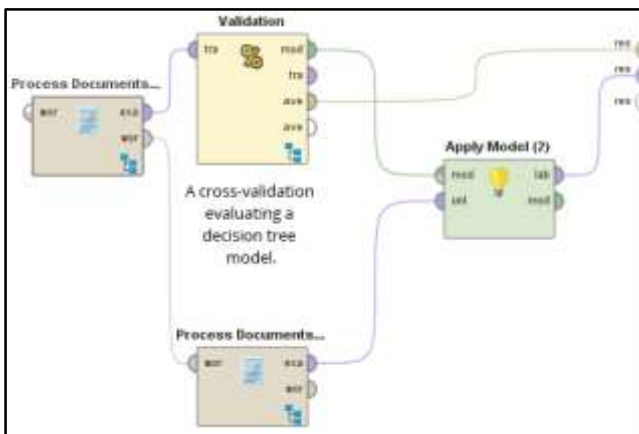

Figure 7. Operator Used in Testing Data Process.

Table 4. The Results from Prediction.

	Label	Pred. (label)	Confidence (spam)	Confidence (nospam)	Meta datafile
1	Don't know	nospam	0.262	0.738	dn_ns08.txt
2	Don't know	nospam	0.357	0.643	dn_ns09.txt
3	Don't know	nospam	0.342	0.658	dn_ns10.txt
4	Don't know	spam	0.831	0.169	dn_ns01.txt
5	Don't know	spam	0.775	0.225	dn_ns02.txt
6	Don't know	spam	0.657	0.343	dn_ns03.txt
7	Don't know	spam	0.782	0.218	dn_ns04.txt
8	Don't know	spam	0.788	0.212	dn_ns05.txt
9	Don't know	spam	0.778	0.222	dn_ns06.txt
10	Don't know	spam	0.828	0.172	dn_ns07.txt

After testing the SVM model with the testing data process, the researcher then conducted three consecutive experiments and computed the average score of a particular n dimension: 2-gram, 3-gram, 4-gram, 5-gram for investigating the highest accuracy of prediction. The results are shown in Figure 8.

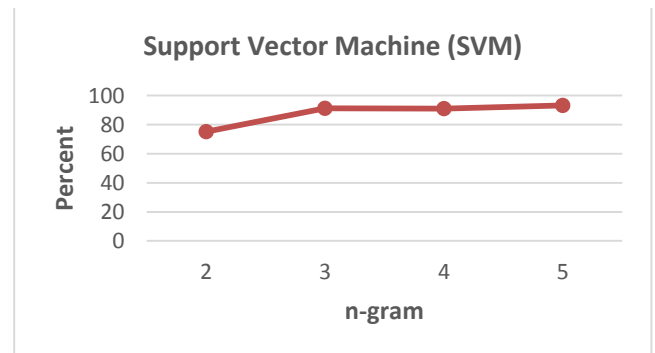

Figure 8. Means of the Model Performance in Different n-Grams.

Regarding the experiment result, it found that 5-gram terms indicated the most accurate prediction which accounts for 93.2%, followed by 3-gram (91.35%), 4-gram (91.18%) and 2-gram (75.31%) respectively.

V CONCLUSION

Spam mail remains one of the dilemmas in electronic mail services which steadily contribute many disadvantageous for the users. The spam mails are

unwanted or unsolicited message that not only sent for commercial purpose, but also transmit viruses, malwares, and spywares to users' computer systems. To reduce computer risk, this paper proposed the integrated approach combing three techniques: Stop-word Removal, N-gram extraction and Classification for screening or filtering spam mail precisely and effectively. This hybrid approach is available to all language used in the world. The experimental result shows that the proposed technique is able to identify spam mail with performance 93.2% of accuracy. Furthermore, the researcher discovered that the number of n dimension which conveys the most precise prediction was 5-grams, following by 3-grams (91.35%), 4-gram (91.18%), and 2-gram (75.31%). Based on the results, it can be concluded that the proposed technique can serve as the effective model to categorize spam mail from other emails. Significantly, the model may be helpful for users either individuals or organizations to avoid and computer risk and cybercrimes. It also can be applied to any other method or theory. To achieve a more accurate prediction

REFERENCES

- Adams, E. (1991). A Study of Trigrams and Their Feasibility as Index Terms in a Full Text Information Retrieval System. *PhD thesis, George Washington University, USA*, 1991.
- Ahn, J. (1996). Using n-Grams for Korean Text Retrieval, *In Proc. Int'l Conf. on Information Retrieval, ACM SIGIR*, Zurich, Switzerland, pp. 216-224.
- Croft, W. (1993). A Comparison of Indexing Techniques for Japanese Text Retrieval, *In Proceedings of ACM SIGIR International Conference on Research and Development in Information Retrieval*, pp. 237-246.
- Kwok, L. (1997). Comparing Representations in Chinese Information Retrieval," in *Proceedings of the 20th Annual International ACM SIGIR Conference on Research and Development in Information on 27-31 July*. Philadelphia, PA: ACM Publication , 34-41.
- Majumder, M. M Mitra and B.B. Chaudhuri. (2002). N-gram a language independent approach to IR and NLP, Kolkata.
- Mansamut, K. (2010). Information Extraction (IE). Retrieved 2015 April 21, From : <https://ejeepss.wordpress.com/2007/10/01/information-extraction-ie/>.
- Mansur, M. Naushad UzZaman and Mumit Khan. (2006). Analysis of N-Gram Based Text Categorization for Bangla in a Newspaper Corpus (Bachelor's Thesis). Department of Computer Science and Engineering, BRAC University, Bangladesh.
- Pacharawongsakda, E. (2014). An Introduction to Data Mining Techniques. (2nd ed.). Bangkok : Asia Digital Printing Limited.
- Puckdeewongs, A. (2003). Anti-Spam Mail System. *Master thesis, M.S., King Mongkut's Institute of Technology North*, Bangkok
- Rojkangsadan, T. (2016). Cognizant of spam. Retrieved 2015 April 22, From : <http://www.dailynews.co.th/it/376076>.
- Spam email datasets. (2010). Retrieved 2016 April 26, From : <http://csmining.org/index.php/spam-email-datasets-.html>.
- Statistics and facts of email marketing. (2013). Retrieved 2015 April 22, From : <http://thumbsup.in.th/2013/06/email-marketing-2013-and-beyond>.
- Todsanai, C. (2014). Using Clustering Techniques for Non-segmented Language Document Management: A Comparison of K-mean and Self Organizing Map Techniques. In the Knowledge Management International Conference (KMICe), 12-15 August. Langkawi, Malaysia.
- Tubsee, H. (2010). Thai Spam Mail Filter Using Neural Network. *Master thesis, M.S., King Mongkut's Institute of Technology North, Bangkok*.
- Yusuk, S (2013). junk mail. Retrieved 2015 April 22 From : <http://www.cdoae.doae.go.th/56/ked-it/15.pdf>.
- Zhihua, W., Jean-Hugues, C., Rui, Z., and Wen, L. (2009). N-grams based feature selection and text representation for Chinese Text Classification. *International Journal of Computational Intelligence Systems*, 2(4), pp. 365-374.

Goal-UML Approach For Modeling Data Warehouse Requirements Of Malaysian Rural Health Care

Sajaratul Huda Shafie, Azizah Ahmad, and Azman Ta'a

Universiti Utara Malaysia, Malaysia, amanhudashafie86@gmail.com, {azie, azman} @uum.edu.my

ABSTRACT

Malaysian health care authorities in providing information system for rural communities required to meet up with the challenges, to provide informed decision-making by utilizes their enormous data. However, only a few of these initiatives have their success stories as many are still struggling to justify the investments such as Data Warehouse System (DWS). Among the most reason of the failures were that DWS requirements were overlooked, leading to poor DWS deployments. This paper attempts to model DWS requirements using goal-oriented and UML-based approach. DWS requirements for Rural health care were modeled two-folds: decision making requirements that centered on stakeholders; and focused on organizational and decisional aspects. The model can guide DWS development in the process and data needed in rural health care strategic decision-making. This provides new insights and facilitates the improvement of new health care knowledge.

Keywords: Data Warehouse, Requirement Analysis, Goal-oriented, Business Intelligence, UML

I INTRODUCTION

The Malaysian health care is facing a lot of challenges as the rural dwellers are accessing to poor health care services (Ali, Dalpiaz & Giorgini, 2010). The consumers of rural health care in Malaysia are mainly those whose purchasing powers are very limited and they are very much dependent of free public services provided by the government. They also have limited choice of accessing other health care providers such as private hospitals, which provide better products and services. Another prominent issue is the present number of health care professionals in the rural health care organizations. On average the rural folks possess less doctors and nurses as compared to their urban and wealthier friends and leaving them in sicker and poorer conditions (Alencar et al., 2000).

Realizing these issues and to overcome these challenges, the Malaysian government has since put in place many initiatives including implementing information systems. These systems require them to gather health care information such as patients, diagnosis, treatment and others, have been storing a massive amount of information in databases throughout the country over the years. However, so

far proper programs are still not in place to analyze these so called 'Big Data' owned by them. Owing massive amount of data, a forward-thinking health care organizations must realize that data and, thus, a concept known as Data Warehouse System (DWS) or Business Intelligence (BI) is at the center of informed and precise decision-making that will improve their services (Bresciani et al., 2004). To achieve the full benefits of DWS in any organizations, there must be a strategic approach to defining decision-making requirements for DWS. The proper modeling of data, analytics and decision-making process should be done for the people in organizations take advantage of their data.

This paper identifies, analyzes decision-making requirements for rural health care center and finally, constructs a DWS requirement model for rural health care centers in Malaysia.

II DATA WAREHOUSE SYSTEM

DWS has emerged as an important area of study for both practitioners and researchers, reflecting the magnitude and impact of data related problems to be solved in contemporary business organizations including health care organizations (Nguyen, Perini & Tonella, 2007). Scholars from different school of thoughts have their own definitions of DWS, but generally it is an umbrella term that includes the applications, infrastructure and tools, and best practices that enable access to and analysis of information to improve and optimize decisions and performance (Ellis-Braithwaite et al., 2013). From a technology point of view, DWS is used for gathering, storing, analyzing, and providing access to data for better business decisions (Kumar & Singh, 2010). Some earlier scholars view DWS as a process of turning data into information and then into knowledge that can be used for good decision-making (Mazon, Pardillo & Trujillo, 2007).

With competitive and complex business environment today, organizations, private or public are under tremendous pressure. They need to respond quickly to changing conditions and be innovative in order to stay competitive. It requires them to be agile and make frequent strategic, tactical, and operational decisions. Making such decision may require considerable amounts of timely and accurate knowledge. Processing these in the framework of the required decisions needs quick, frequent and some computerized support, which is traced to DWS

(Giorgini, Rizzi & Garzetti, 2008). Making DWS a success story is the real challenge for organizations, among the main factors that mentioned in the literature is that DWS doesn't fulfill their decision-making requirements. Many DWS systems failed to deliver the promised 'knowledge' needed by decision makers.

Requirement plays a very important aspect of DWS implementation, where poor requirements management can lead to project failure. DWS project managers need to acquire necessary skill in order to optimize the results and to minimize problem during DWS requirements elicitation. DWS requirements analysis can be classified in two categories: i) data-driven approaches starting from analysis of data sources; user requirements impact on design by allowing the designers to select which chunks of data are relevant for decision making and by determining their structure according to the multidimensional model; and ii) requirement-driven start from determining the information requirements of end users, and how to map these requirements onto the available data sources. Data-driven approaches simplify the design, but they give end-user requirements a secondary role. On the other hand, requirement-driven approaches start by determining the information requirements of end users, which bring requirements to the foreground, but it requires larger efforts when designing as it needs a more structured method.

Information systems scholars have come up with techniques for modeling that help analyze and understand requirements for systems such as Context Diagram, Entity Relationship Diagrams and Sequence Diagram. But most of these modeling techniques only cater for the operational type of information systems, whereas DWS is a strategic information system that has different needs in terms of data as well as processes.

A. Requirement Modeling with Goal-oriented Approach

In the field of DWS design, Giorgini et al. (2003) proposed Agent-Goal-Decision-Information (AGDI) model to support the early and late requirements for development of DWSs from the stakeholders' perspective. This model also supports three interrelated modeling activities, namely, organization modeling, decision modeling and information modeling. Gupta et al. (2011) proposed a comprehensive method in order to determine information requirements of DWS users and match these requirements with the available data sources. The activity model represents the core component of a comprehensive methodology for information requirements analysis for DWS systems.

Requirement analysis is split in two which is early and late requirement analysis in designing phase (Horkoff & Yu, 2012). Maté, Trujillo & Franch (2014) stated that during the first phase, domain stakeholder and model will be identified as social actors, and in late requirement analysis, the conceptual model will be designed consisting of new actor and a number of dependencies with other actors. Lujan-Mora (2005) presented the comparison between different approaches to analysis the goal-oriented requirement models, to understand the ways in which procedural design choices affect results.

The sufficient requirements to support the decision making process are required to manage the DWS changes correctly. This will help the information provided will meet the business goals. However, the requirements for DWS are difficult to decide from the goal of the decision maker or organization since the current DWS modeling does not consider the goal concept in the model (Giorgini, Rizzi, & Garzetti, 2008). All the prerequisites must be squared up, identified and analyzed within early and late requirement analysis by using suitable modeling.

Requirement analysis is split in two which is early and late requirement analysis in designing phase (Wirtz et al., 2006). This stated that during the first phase, domain stakeholder and model will be identified as social actors, and in late requirement analysis, the conceptual model will be designed consisting of new actor and a number of dependencies with other actors, meanwhile in architectural and detail design phases focus on the DWS detailed design specification in the implementation phase.

In the perspective of goal-oriented approach, Giorgini, Rizzi & Garzetti (2008) presented the comparison between different approaches to analysis the goal-oriented requirement models, to understand the ways in which procedural design choices affect results. They were advocated goal-oriented to capture and link technical requirements to derive high-level or details user requirements using elicited goals, capture and compare alternative potential implementations. Several applications of goal-oriented techniques in different modeling frameworks, techniques, or methodology include KAOS, GBRAM, NFR, i*, Tropos, GRL, and AGORA.

Mazon, Pardillo & Trujillo (2007) proposed a GORE approach for modeling, organizational goals that the DWS supports and relating them to the information required and to use the i* modeling framework and the model driven architecture (MDA) in order to describe (i) how to model goals and information requirements for DWSs, and (ii) how to derive a conceptual multidimensional model that provides the required information to support the decision making process. Computation independent model (CIM) is specified by

using the i* modeling framework in order to model goals and information requirements for a DWS and then the conceptual multidimensional model of a DWS is derived from the CIM into the platform independent model (PIM).

B. Tropos Methodology

Tropos is an agent-oriented software engineering methodology (Giorgini, Rizzi & Garzetti, 2008). In DWS design, Tropos can be used as goal-oriented approach to requirement analysis in two perspectives of modeling which is organizational modeling and decisional modeling. Tropos has proposed a few steps in goal analysis named GRAnD as shown in Figure 1. GRAnD methodology that encompassed these two modeling supports from early phases of requirements analysis to detailed design that focused on the understanding of the environment where the DWS must operate, and provides communication between analyst and stakeholder in the decision-making process.

There are four phases in Tropos methodology consist of early requirements, late requirements, architectural design, and detailed design. Early requirement concerned about the intentions of stakeholder that underlie in DWS design, problem in the decision-making process on organizational setting, exploring system solution and alternatives, and it must be done before UML modeling.

Early requirement analysis proposes two main diagrams which are the actor diagram and the goal diagram in goal analysis. Tropos has adopted Eric Yu's i* model, which offer actors (agent, roles or position), goals, and actor dependencies in the early requirement modeling. Late requirement analysis defined the requirement specifications, including functional and non-functional requirements for the DWS design. Meanwhile, architectural design defined the interconnected through data, control and dependencies, and detailed design defined the behavior of each component.

Figure 1 shows the Tropos notation that used in DWS design. An actor is represented as stakeholder. In a health care domain, there are Ministry, Hospital and Clinic. An actor related by dependencies to the other actor to achieve the goal in actor diagram. Actor diagram is a model to show how the actor depending on another actor to respect the goal of the organization. Meanwhile, rationale diagram is used to represent the model goals and sub-goals of actors.

There are a few new concepts required in DWS context by using Tropos, which are facts, attributes, dimensions, and measures. Fact is a set of events that happen when the goal is achieved, attribute is a value provided when the fact is recorded to achieve the goals, dimension is a facts property to fulfill the

analysis goal and measures is a numerical property of a fact related to the decision making.

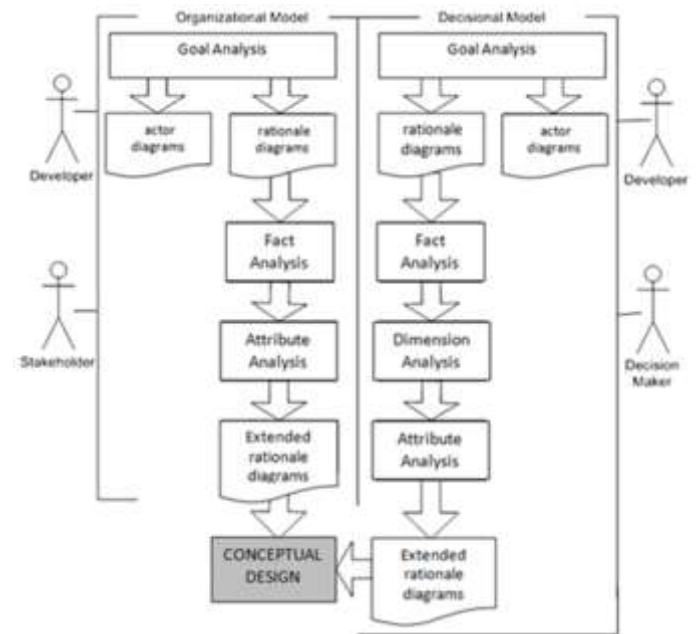

Figure 1. The GRAnD Approach

Figure 2 shows the notation that used in DWS design. An actor is represented as stakeholder. In a health care domain, there are Ministry, Hospital and Clinic. An actor related by dependencies to the other actor to achieve the goal in actor diagram. Actor diagram is a model to show how the actor depending on another actor to respect the goal of the organization. Meanwhile, rationale diagram is used to represent the model goals and sub-goals of actors.

There are a few new concepts required in DWS context by using Tropos, which are facts, attributes, dimensions, and measures. Fact is a set of events that happen when the goal is achieved, attribute is a value provided when the fact is recorded to achieve the goals, dimension is a facts property to fulfill the analytical goal and measures is a numerical property of a fact related to the decision making.

In the result sections, the phases are described in detail with reference to real case study, the Malaysian Rural Health Care Centers. The system used in hospital and clinic is not integrated with each other. This causes the management of information and decision-making between medical practitioners and staffs has a difficult time to organize and utilize these volumes of patient's data effectively and efficiently. This indicates it is a necessity for implementing the DWS concept in this institution's health care as a solution to integrate the system in order to collect and distribute the health care data.

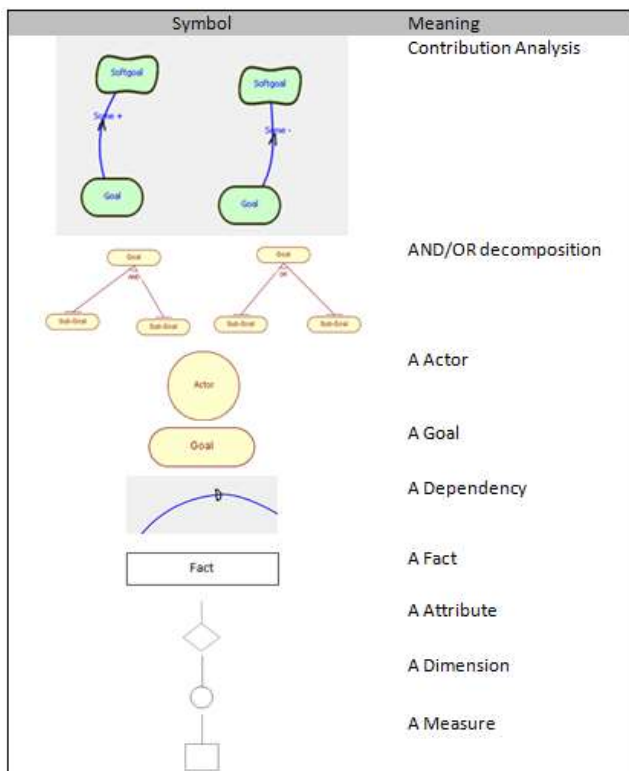

Figure 2. Notation for Actor and Rationale Diagram

III HEALTH CARE ORGANIZATIONS

The global health care environment has widely divergent perspectives on the use of data and information for decision-making. The ability to collect and analyze data garnered from the point of patient care has been impressive. Health Care delivery, however, has often been plagued by under funded, less advanced methods of collecting and analyzing data. Most providers continue to use (EHR) systems and strive to integrate systems that combine both clinical and administrative data. Through this transition, health care provider organizations can take advantage of this data and explore analytics as a competitive tool as a method to help provide better care, improved outcomes and safer, more effective decision making. Taken together, systems and data cannot solve all of the problems that face health care system alone. This requires an eye toward setting the strategy based on sound fundamentals along with policy decisions that govern the operations of health care environment. Hence, exploring and understanding the health care requirements of DWS is vital in order to achieve the goals.

There are a lot of issues in rural health care spanning from managing medical professionals related to clinical problems. The successful implementation of rural health care in Malaysia requires competence and professional benchmark, which embedded patient in the values and behavior. The rural health care staffs in

Malaysia have witnessed upgrading in knowledge and skills to sustain the right value and attitudes. One of the contemporary issues bordering Malaysian rural health care is the number of health workers and their distribution. The fact that the number has been increasing over the year, the effect is yet to be felt in catering for the rural dwellers while their demands are yet to be met. The issue of distribution of experience and skillful health care professionals in Malaysian rural areas can be tackled by applying DWS as a measure. Despite the great strides made in socioeconomic development, there are still remains pockets of disadvantaged communities such as aborigines in the remote rural areas. The disadvantaged and marginalized groups in the rural areas need to be alleviated in achieving successful rural health care services in Malaysia. Nevertheless requirement analysis for DWS health care systems, in this case rural health care, has not been given much attention so far. DWS requirement analysis is often neglected due to: i) the projects are long-term ones, in which most requirements cannot be stated from the beginning; and ii) requirements are poorly shared across organizations, unstable in time, and refer to information that must be derived from data sources. Several surveys indicated that a significant percentage of DWS projects fail because the requirement analysis is overlooked.

IV METHODOLOGY

This study employed a qualitative approach, where interview and documents, sampling methods were used to collect relevant health care data needed for the modeling process. The semi-structured interviews with 15 health care staffs including 8 medical doctors, 5 nurses and 2 administration staff from 5 rural health care centers in Kedah and Perlis were administered. The relevant documents were also sampled to get in depth views on health care data, processes and decision making activities. These interviews were analyzed by the content analysis method and the results were used to model DWS requirements. Goal-oriented requirements analysis and design (GRAnD) proposed by Giorgini, Rizzi & Garzetti (2008) were adapted to model the requirements and the modeling results are discussed in detail in the following sections.

V MODELING DATA WAREHOUSE

Based on content analysis result on interview data and document sampling, 2 types of modeling were performed. Based on GRAnD method, DWS health care were modeled according to organization in order

to get the stakeholder's point of view, and decisional to get their goal and decision-making activities.

A. Rural Health Care Organization Modeling

The organizational modeling represents the main data in the organization and comprise most relevant attribute to data sources. The organizational modeling consists of three types of analyses which is goal analysis, fact analysis, and attribute analysis and produced lists of facts and attributes.

Goal analysis

The first step in goal analysis represents the intentions of relevant stakeholder for the organization and their dependencies in actor diagram. Follow by analysis to decomposing the high level goal into sub-goal as shown in Figure 3.

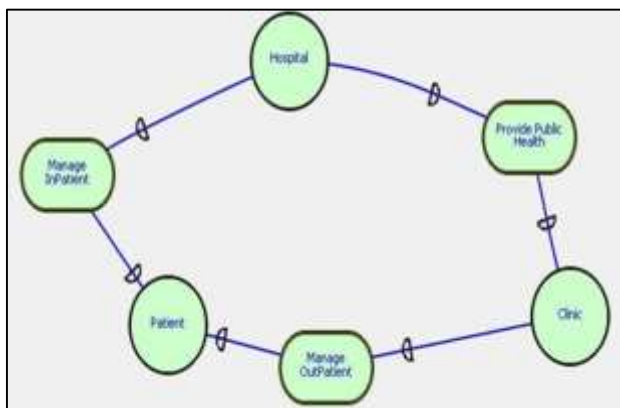

Figure 3. Actor Diagram for Rural Health Care.

The second step produced a rationale diagram for each actor in actor diagram for Rural Health Care as Figure 4. Goals are AND decomposed to sub goals and contribution link between goals are discovered. The analysis ends when all the goals of each actor have been analyzed and all the dependencies among actors are established in actor and rationale diagrams. The previous rationale diagram from goal analysis is used to identify all the relevant facts for the organization. At this phase of view, the analyst navigates the rationale diagram for each actor and extends it by associating goals with facts. The fact OPD Services is associated with the goal Provide OPD Services. The information is collected using two different types of template which are (Fact, Description) and (Goal, Fact).

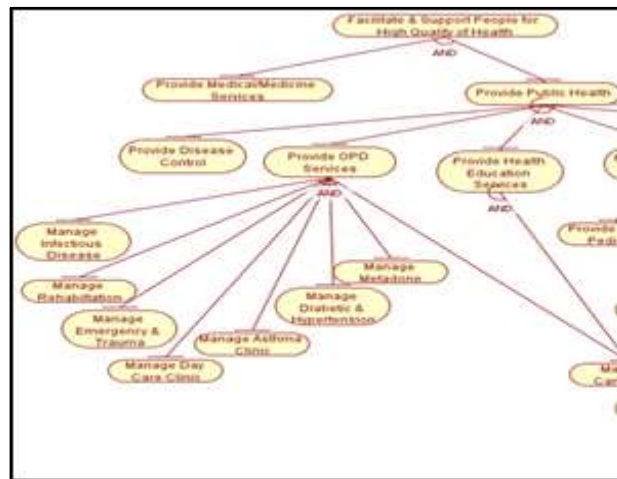

Figure 4. Rationale Diagram for Rural Health Care: Public Health (Organizational Modeling)

Attribute analysis

All the attributes that are given a value is identified when facts are recorded. Starting from the previous diagram, the entire related attribute for the sub-goals are explored. The attributes are simply data that associated with the goals. The information is collected by using table (Attribute, Goal, and Fact).

B. Rural Health Care Decisional Modeling

Decisional modeling consists of four types of analyses which is goal analysis, fact analysis, dimension analysis and measure analysis to support the decision making and produced lists of facts, dimensions and measures. Decisional modeling is focused on how the DWS supports the decisional process of the organization, and the requirements of the DWS from the perspectives of the decision maker. The previous diagram for organizational modeling is used to support the identification of the facts that to be associated with the decision maker goals.

Goal analysis

In this analysis phase, goal analysis starts with analyzing the actor diagram for the decision maker. A decision maker is identified and initial dependencies between them were established. The goals are the decomposed to produce rationale diagrams.

Fact analysis

A rationale diagram for organizational modeling is used to identify the facts and as associating it to goals of decision makers. Basically, the facts for rationale diagram are imported from a rationale diagram in organizational modeling.

Dimension analysis

In dimension analysis, each fact is related to the dimensions that decision maker considers to achieve the decisional goals. Dimensions are identified by

analyzing the goals and facts from a rationale diagram of decision maker.

Measure analysis

Finally, a set of measures is associated to each of facts from previous diagram. A measure is a numerical property of facts that relevant to the decision making process.

The organizational model produced by requirement analysis represents the main data that comprises the most relevant attributes that are part of the source database. On the other hand, the decisional model describes the decision maker's needs, which summarizing the role played by an actor associates to the facts, dimensions and measures. The requirements derived from organizational and decisional modeling are matched with the schema of source database to generate the conceptual schema for Malaysian Rural Health care. There are three phases involved, which are requirement mapping, hierarchy construction and refinement based on GRAnD. Facts, dimensions, and measures from extended rationale diagrams are mapped onto the source schema. Every dimension associated with a goal related and successfully mapped to the decisional model to the source is included in the conceptual schema. Figure 5 shows the finding of conceptual schema for rural health care DWS. The model shows that the dimensions are associated mapped to facts from decisional model to source schema with many-to-one relationship. Every measure associated mapped to a goal related to facts from a decisional model to the source schema and provide many-to-one relationship.

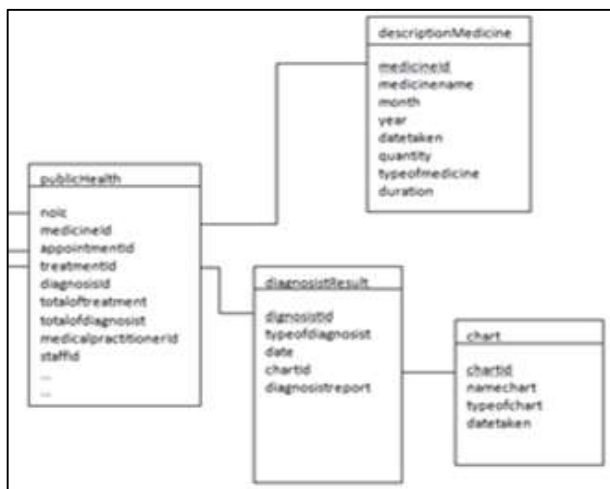

Figure 5. Conceptual Schema For Rural Health Care

VI CONCLUSION

This paper proposes a model of DWS requirements for Malaysian rural health care. A goal-oriented

methodology for requirement analysis in DWS is explored. The goal-oriented modeling is proposed to capture the requirements of DWS from stakeholders' perspective, which are organizational modeling and decisional modeling. The approach captured and analyzed the early requirements for the Malaysian health care focused on rural health centers by using the Tropos Methodology. The adoption of GRAnD in this modeling approach can help the designer to reduce the risk of project failure and at the same time, makes the design of DWS simpler. The modeling results proved that GRAnD can be used as a language as well as method to derive data warehouse conceptual schema.

REFERENCES

- Ali, R., Dalpiaz, F., & Giorgini, P. (2010). A goal-based framework for contextual requirements modeling and analysis. *Requirements Engineering*, 15(4), 439-458.
- Alencar, F. M., Castro, J., Cysneiros Filho, G. A., & Mylopoulos, J. (2000, July). From Early Requirements Modeled by the i* Technique to Later Requirements Modeled in Precise UML. In *WER* (pp. 92-108).
- Bresciani, P., Perini, A., Giorgini, P., Giunchiglia, F., & Mylopoulos, J. (2004). Tropos: An Agent-Oriented Software Development Methodology. *Autonomous Agents and Multi-Agent Systems*, 8(3), 203-236.
- Nguyen, D. C., Perini, A., & Tonella, P. (2007, May). A goal-oriented software testing methodology. In *International Workshop on Agent-Oriented Software Engineering* (pp. 58-72). Springer Berlin Heidelberg.
- Ellis-Braithwaite, R., Lock, R., Dawson, R., & Haque, B. (2013). Towards an approach for analysing the strategic alignment of software requirements using quantified goal graphs. *arXiv preprint arXiv:1307.2580*.
- Kumar, M., & Singh, Y. (2010). Stakeholders driven requirements engineering approach for data warehouse development. *Journal of information processing systems*, 6(3), 385-402.
- Mazon, J.-N., Pardillo, J., & Trujillo, J. (2007). A Model-Driven Goal-Oriented Requirement Engineering Approach for Data Warehouses. *LECTURE NOTES IN COMPUTER SCIENCE*, (4802), 255-264.
- Giorgini, P., Rizzi, S., & Garzetti, M. (2008). GRAnD: A Goal-Oriented Approach to Requirement Analysis in Data Warehouses. *Decision Support Systems*, 45, 4-21.
- Giorgini, P., Kolp, M., Mylopoulos, J., & Pistore, M. (2003). The Tropos methodology: An overview. *Methodologies And Software Engineering For Agent Systems*, Kluwer Academic Publishing (New York).
- Gupta, V., Chauhan, A., Kumar, A., & Taneja, S. (2011). UREM-A UML-Based Requirement Engineering Model for a Data Warehouse. In *Proceedings of the 5th National Conference*.
- Horkoff J. & E. Yu. (2012). Comparison and evaluation of goal-oriented satisfaction analysis techniques. doi: 10.1007/s00766-011-0143-y
- Maté, A., Trujillo, J., & Franch, X. (2014). Adding semantic modules to improve goal-oriented analysis of data warehouses using I-star. *Journal of Systems and Software*, 88, 102-111.
- Lujan-Mora, S. (2005). *Data Warehouse Design With UML*. Unpublished PhD, University of Alicante.
- Wirtz, K., Tauscher, M., Zwerenz, M., Munte, A., und Strategie, V., & Bayern, K. V. (2006). Data warehousing for Bavarian Out-Patient Public Health Care. In *ECEH* (pp. 263-274).

Does Difference in Secondary and Tertiary Literacy Influence Life Insurance Consumption in The Selected ASEAN Countries?

Lee Hui Shan¹, Kevin Low Lock Teng², Chong Shyue Chuan², and Sia Bik Kai²

¹Universiti Tunku Abdul Rahman (UTAR), Universiti Putra Malaysia (UPM), MALAYSIA, huishan.leehuishan@gmail.com

²Universiti Tunku Abdul Rahman (UTAR), MALAYSIA, {lowlt, chongsc, siabk}@utar.edu.my

ABSTRACT

Life insurance as financial tool has played essential roles to both individual and economy with the functions of promoting long term saving, reinvestment of funds, risk management, development of capital markets support on economic growth. The determinants of life insurance consumption in the perspective of economics and demographic are to be examined in the ASEAN context. The study on the difference of secondary and tertiary education towards demand for life insurance is investigated to highlight the importance of introducing insurance knowledge in the education syllabus to improve future economics with better income and social return with the support of life insurance in the market. This will ensure a well risk management among individuals, firms and countries as a whole and it align with the AEC blueprint with the purpose to rise up the living of the community.

Keywords: life insurance, income, youth dependency, tertiary education.

I INTRODUCTION

A key landmark in the regional economic integration agenda in ASEAN 2015 is to embark on ASEAN Economic Community (AEC). One of the five core blueprints is “A Resilient, Inclusive, People-Oriented, and People-Centred ASEAN” which focus on providing an enabling environment access to the formal financial system in addition to increase awareness, encourage and develop social business in empowering communities to generate revenue and social returns to improve the well-being and livelihood of the people (ASEAN, 2015). Outreville (1990 and 1996) and Beck and Webb (2003) suggested that life insurance as financial tool has played essential roles to both individual and economy with the functions of promoting long term saving, reinvestment of funds, risk management, development of capital markets support on economic growth. Outville (1996 and 1999) claimed that human development elements play significant relationship to the life insurance consumption and economic development in the developing countries. In view of the factors of human capital determine the utilization of life insurance which ensures the risk management of individuals, firms and countries as a

whole and it align with the AEC blueprint with the purpose to rise up the well-being of the community, thus, the investigation on the factors that influence the life insurance consumption in ASEAN countries, especially on the attributes of literacy is crucial. The purpose of this paper is to examine the difference in secondary and tertiary literacy impact on the consumption of life insurance in the selected ASEAN countries.

Financial sector of many Asian countries passed through a stage of restructuring in the institutions in the 1990s. Lee and Park (2009) presented that in meeting the rising demand for financial services in Asian countries, the improvement on the performance and strength of financial institutions such as banking and insurance are needed. Sen and Madheswaran (2013) highlighted that the detail investigation on the performance of the insurance sector in Asian countries was lack of global standards. They explored the factors of life insurance demand in the selected Asian economies to complement the studies by Truett and Truett (1990), Li, Moshirian, Nguyen and Wee (2007) and Outreville (2011) which focuses on United States region, OECD countries and selected countries from the world. However, there is still lack of study on the life insurance consumption in ASEAN countries in the literature. From Table 1, 7 countries out of 10 countries in ASEAN shows positive change in the life insurance premium volume to GDP (%) from 1997 to 2010, which shows that the consumption of life insurance has increased for the past two decades for most of the countries in ASEAN. Thus, the present paper endeavors to assess the attributes that contribute to the consumption of life insurance in ASEAN countries. To be more specific, it entails two crucial objectives. First, it investigates the economic and demographic factors in influencing life insurance consumption in selected ASEAN countries. This study is imperative to illustrate whether developing countries in ASEAN will contribute to the demand for life insurance. Second, it intends to divide the literacy level into two segments which are secondary and tertiary literacy in order to determine the differences in influencing life insurance demand. This study differs from previous studies that it attempts not only to illustrate literacy influence life insurance consumption but it also highlights at what

level of literacy will influence the decision to acquire life insurance.

This paper is put in order as follows. In the next section, the relevant literature will be reviewed. Section 3 explains data and methodology. Section 4 presents data and discussion on the results. Finally, section 5 contains a summary of the main findings.

Table 1. Life insurance premium volume to GDP (%) in ASEAN.

	1997	2010	% Change from 1997 to 2010
Singapore	2.878	4.247	48%
Malaysia	2.114	3.058	45%
Thailand	1.242	2.887	132%
Brunei	0.747	0.44	-41%
Philippines	0.698	0.786	13%
Indonesia	0.561	1.085	93%
Myanmar	0.012	0.004	-67%
Vietnam	0.005	0.632	12540%
Lao PDR	0.002	0.011	450%
Cambodia	Data not available		

(Source: The World Bank)

II LITERATURE REVIEW

Hueber (1916) was one of the pioneer researchers who suggested that the importance of life insurance consumption as the qualitative prospects of human life that provides economic values. The significance of insurance service is not only narrowed to risk transfer, allocation and absorption but also the mobilisation and reinvestment of funds for the utilisation by financial markets to encourage the investment and growth induction (Alhassan and Fiador, 2014).

The classical Keynesian consumption hypothesis and permanent income hypothesis described individual consumption styles in relative to income, price, and interest rate. It is undeniable that human lives surrounded with uncertainties associated with the time of death, nevertheless, human can improve lifetime benefit through the purchase of a life insurance policy and can provide a bequest for their dependents. Hence, insurance engages a vital role in smoothing the utilisation, bequest or repayment of debt when the insurance purchasers discontinue receiving a stream of income (Pissarides, 1980).

Yuan and Jiang (2015) studied the determinants that concern the demand for life insurance in China, The results postulated that income level was one of the common economic factor, and the demographic factors such as education, development of social security pension, children and elderly dependency ratio were the main factors the affect life insurance

demand. In the case of Poland, Slimwinski, Michalski and Roszkiewicz (2013) confirmed that economic factors strongly motivate the demand for life insurance but one of the demographic factors which is education was found to be contradicted with the previous study where it did not affect the life insurance consumption.

Cross sectional analysis were done by some researchers such as Browne and Kim (1993) mainly focusing on economic variables. They divided 2 sample periods in 1980 and 1987 respectively over 45 countries and recommended that income was positively affecting life insurance consumption but inflation was negatively related to life insurance demand. In regards to demographic factors, Outreville (1996) employed the percentage of the labor force with tertiary education as a proxy variable for education (human capital endowment) to studied its impact to life insurance consumption by using bivariate, multivariate and auxiliary regression but failed to exhibit positive relationship. Later, Outreville (2015) used survey questionnaire analysis on developed and developing countries for cross sectional data and concluded that negative significant association between relative risk aversion and the level of education which leads to lower demand for life insurance. The studied by Outreville (1996 and 2015) were contradicted with the literature by (Browne *et al.*, 1993; Ward and Zurbruegg, 2002; Hwang and Gao, 2003; Beck *et al.*, 2003) which recommended a positive significant link between risk aversion and education level that resulted on higher awareness on the necessity of life insurance.

Sen (2013) diverted the research on the determinants of life insurance consumption to the developing countries in Asian region which is mostly different from the past studies that centred on the European countries or United States countries. The low insurance market penetration in Asian region was due to the restriction entry by the foreign insurance companies and required partial or full ownership by the government. However, in the past decade, the insurance industry in Asian region had postulated expansion in life insurance industry due to the liberal policies and regulatory changes. Simultaneously, economics and human social features were among the factors that contribution the expansion of awareness and consumption in life insurance. Income, inflation, and real interest rate and youth dependency ratio were found significantly impact life insurance consumption. In addition, urbanisation and literacy rate which were the few determinants to be included by the past literatures were established to significantly impact life insurance consumption

As a summary from the literature reviews, gross domestic product, income, interest rate and inflations

are among the economic variables that influence life insurance consumption. Moreover, youth dependency rate, urbanisation and education were among the demographic variables that determine the life insurance consumption. Founded on these studies, most of the economic variables are significantly influence life insurance consumption. Nevertheless, the issue as whether the demographic variables are significantly influence life insurance consumption seems to receive mixed evidence. More specifically, education may influence certain countries based on the nature of development. In the present study, the highlighted contribution is to separate the education level in order to assess whether the difference in education level will influence the life insurance consumption in selected ASEAN countries. It is believed that to include the study on the difference in education levels will enhance the insurance company's strategy in approaching potential customers, improve the social return and assist in stable economic growth in the ASEAN countries.

III DATA AND METHODOLOGY

The ASEAN countries selected are Malaysia, Thailand, Philippines and Indonesia from 10 of the ASEAN economies. Singapore is not selected due to its background as a developed country which may deviate the study results compared to the other 9 countries which are not developed countries. Brunei and Myanmar are not in the sample as they demonstrated negative growth in life insurance premium volume to GDP for the past decade. Vietnam and Lao are not included in the analysis as the insurance penetration were far lower compared to the other selected countries both in 1990 or 2010. Cambodia is excluded as the data is not accessible. The sample period cover in this study is from 1990 to the recent data availability in 2013 and also due to the financial sector of many Asian countries passed through a stage of restructuring in the institutions start from 1990s (Lee et al., 2009). The data is extracted from The World Bank.

The dependent variable is the percentage of life insurance premium volume to GDP and independent variables are segmented to economic and demographic variables as illustrated in Table 2.

Table 2. Independent Variables of Life Insurance Consumption.

Segment	Variable	Explanation
Economics	GDP per capita, GDP	GDP per capita is gross domestic product divided by midyear population.

	Inflation (%), INF	Inflation as measured by the consumer price index reflects the annual percentage change in the cost to the average consumer of acquiring a basket of goods and services.
	Real interest rate (%), RIR	Deposit interest rate minus the inflation rate.
Demographic	Urbanisation, URB	Urban population refers to people living in urban areas as defined by national statistical offices.
	Youth dependency ratio, YOUTH	The ratio of younger dependents-people younger than 15.
	Life expectancy, LIFE	Number of years a newborn infant would live if prevailing patterns of mortality at the time of its birth were to stay the same throughout its life.
	Secondary enrolment ratio, SEC	Completes the provision of basic education that began at the primary level, and aims at laying the foundations for lifelong learning and human development.
	Tertiary enrolment ratio, TER	Requires minimum condition of admission, the successful completion of education at the secondary level.

(Source: The World Bank)

Table 3. Expected result of Independent Variables towards Life Insurance Consumption.

Variable	Expected Result	Rationale
GDP per capita, GDP	positive	As a proxy for income that indicates higher income will support life insurance consumption.
Inflation (%), INF	negative	Inflation and its instability to have a reverse relationship with the demand for life insurance.
Real interest rate (%), RIR	positive	Higher rates are expected to increase investment returns of life insurance and hence the profitability and as the consequence, insurer could offer higher financial benefits to insured. Thus, it will stimulate the demand for life insurance sales through

		consumer expectations.
Urbanisation, URB	positive	Growing of urbanisation indicates development of economics that experiencing the number of children declines, expenditures on cost of children will decline that leads to saving accumulation through investment in life insurance.
Youth dependency ratio, YOUTH	positive	To reduce the risk of uncertainties in raising up the children, the family is in favour of life insurance to protect their children's future.
Life expectancy, LIFE	positive	Expected living age is longer requires income benefits from insurance retirement plan that supports higher demand for life insurance.
Secondary enrolment ratio, SEC	positive	Education in secondary school enables the students to understand the basic needs that could encourage consumption in life insurance to protect future income.
Tertiary enrolment ratio, TER	positive	Higher education in tertiary level that makes the individual understands how the insurance functions that provide safeguard to their future and guides them to acquire life insurance.

The data will be analysed through panel data regression model as it is practical in controlling individual (cross-section) heterogeneity and consequences which are complicated to be observed through pure cross sections or pure time series data.(Gujarati and Dawn, 2009). Stata software is used to run the panel data.

As recommended by Sen (2013), the estimated equation by taking percentage of life insurance premium volume to GDP as the proxy for life insurance consumption is as follows:

$$\log(PREM)_{it} = \alpha_i + \beta_1 \log(GDP)_{it} + \beta_2 (INF)_{it} + \beta_3 (RIR)_{it} + \beta_4 \log(URB)_{it} + \beta_5 \log(YOUTH)_{it} + \beta_6 \log(LIFE)_{it} + \beta_7 \log(SEC)_{it} + \beta_8 \log(TER)_{it} + \varepsilon_i$$

Firstly, pooled ordinary linear regression model (Pooled OLS) is exploited to present result based on poolability of the data but disregards the panel structure of the data. The second model to be employed is random effect model (REM) which handles the constants for each section as random

parameters. The third model is fixed effect model (FEM) where the constant is treated as group specific which means the model allows for different constants for each country. The selection between pooled OLS and REM is based on Breusch-Pagan Lagrangian Multiplier (BPLM) Test where the null hypothesis refers to Pooled OLS is preferred versus alternative hypothesis refers to REM is preferred. The choice between REM and FEM is based on Hausman Test where the null hypothesis refers to REM is preferred (Gujarati et al., 2009). Robustness check will be used to test for heterogeneity and serial correlation.

IV DATA ANALYSIS

Table 4 demonstrated the descriptive statistic for the data.

Table 4. Summary of Descriptive Data.

Variables	Obs	Mean	Std Dev	Min	Max
PREM	95	1.482	0.961	0.216	3.663
GDP	96	2533.281	1724.459	827.2374	7051.793
INF	96	5.814	6.507	-0.846	58.387
RER	96	2.158	4.047	-19.32	13.9
URBAN	96	4.21E+07	3.28E+07	9068034	1.31E+08
YOUTH	96	49.618	12.471	25.322	73.212
LIFE	96	69.420	3.172	63.260	74.568
SEC	89	65.585	13.798	28.505	88.389
TER	86	26.515	11.760	7.190	52.747

The result in Table 5 represents the outcome based on panel data model as discussed in section 3. The poolability test will be employed to examine the feasibility of poolability among the independent variables in a panel although it is presumed that in a panel the character of heterogeneity will be controlled (Baltagi, 2005).

In model 1, five variables namely GDP per capita, inflation, real interest rate, youth dependency ratio and tertiary education significantly influence life insurance consumption. GDP per capita is the proxy for income, the result recommends that life insurance consumption increases with income which could due the reason that an individual's consumption and human capital classically rise in tandem with income, allowing a higher demand for insurance to protect the his potential of income and the anticipated consumption of his dependents. Beck *et al.* (2003) also proposed that life insurance could be a luxury good as when a person's income rise, he would spend a larger proportion of his income to invest in investment-linked life insurance product. The result shows negative significant relationship between inflation and demand for life insurance which is consistent with the finding by Outreville (1996), Ward *et al.* (2000), Li *et al.* (2007), Sen *et al.* (2013).

When inflation increases, life insurance product becomes less desirable good. This is probably due to the disruptive effect of inflation towards monetary benefits which makes the monetary benefits become uncertain that could result in negative return on the insurance benefits hence it erodes the value of life insurance. However, the inflation result contradicts with the finding by Yuan and Jiang (2015) which recommended that the stable moderate increase in inflation signalling a stable economic growth in China that encouraged the demand for life insurance. This might indicate that the economic growth in ASEAN countries are subjected to volatility. The third variable shows significant negative result toward life insurance consumption is real interest rate. The main reason for the negative impact which is different from the expected result could be due to

the greater preference of ASEAN individuals for immediate consumption compared to deferred consumption that discourage them in purchasing life insurance. Another reason as suggested by Li *et al.* (2007) could be due to availability of other products than life insurance that offer higher expected benefits as opposed to insurance. The forth significant variable is youth dependency ratio which exhibits negative relationship in relative to life insurance consumption which indicates a contrarily outcome to the expected result. This could be probably due to the needs to raise up children that amplifies the expenditure of a family, the higher burden of a family leads to unwillingness to allocate some expenditure on life insurance which could only provide benefits in the future but not current.

Table 5. Results of Panel Data.

Independent Variables	Pooled OLS		REM Model 3	FEM Model 4	FEM (Robust) Model 5
	Pooled OLS Model 1	(Robust) Model 2			
Constant	-5.410 (12.745)	-4.918 (25.691)	-5.409 (12.744)	-111.28*** (19.318)	-81.476*** (11.777)
GDP	0.719*** (0.175)	0.592* (0.306)	0.719*** (0.174)	0.273 (0.286)	-0.656* (0.240)
INF	-0.019*** (0.006)	-0.011 (0.007)	-0.018*** (0.005)	-0.024*** (0.004)	-0.011 (0.006)
RIR	-0.029*** (0.010)	-0.014 (0.014)	-0.029*** (0.010)	-0.037*** (0.008)	-0.020 (0.011)
URB	-1.77e-12 (1.04e-9)	-3.89e-09 (3.24e-09)	-1.77e-12 (1.04e-09)	-2.21e-08*** (3.30e-09)	-2.34e-08*** (7.30e-10)
YOUTH	-3.207*** (0.165)	-0.854*** (0.158)	-0.840*** (0.165)	0.911** (0.446)	2.188*** (0.333)
LIFE	0.875 (3.206)	1.344 (6.197)	0.875 (3.206)	24.969*** (4.378)	18.514*** (2.700)
SEC	0.128 (0.199)	0.051 (0.198)	0.128 (0.199)	0.386** (0.180)	0.559** (0.102)
TER	-0.235** (0.096)	-0.464*** (0.173)	-0.235** (0.096)	-0.128 (0.101)	-0.137 (0.074)
Observations	79	79	79	79	79
F-Test/Chi	132.02***		1056.18***	47.85***	
Within	-	0.851	0.739	0.851	0.9348
R2 Between	-	0.999	0.999	0.719	0.2615
Overall	0.9378	0.964	0.9378	0.677	0.4134
BPLM Test			1.13		
Hausman Test				56.24***	
Wald Test				33.62***	
Woolridge test-autocorrelation				12.93**	

Note: Figures in parentheses are standard errors.
*, **, *** indicate statistical significance at 10%, 5% and 1% respectively

Lastly, tertiary education level exhibits and unexpected negative significant sign towards life insurance consumption. The rationale could be due to tertiary education level fail to increase the awareness on the importance of life insurance as they do not understand the complexity of insurance products because these information may not be educated in schools (Sen *et al.*, 2013).

Following the poolability test outcomes, the robust Pooled OLS is performed to improve the existence of heterogeneity and autocorrelation in model 1. The outcome in model 2 also supports 3 significant variables out of 5 from model 1, namely income, youth dependency ratio and tertiary education level. In model 3, it is assumed that the intercept is a random variable with a mean value for all sample countries. However, the result of BPLM Test does not reject null hypothesis indicates that pooled OLS is preferable to REM. Hausman test is carried out to measure the suitability between REM and FEM. The result rejects null hypothesis which demonstrates that REM is not suitable. Model 5 is the robust of FEM to improve the issue of heterogeneity and autocorrelation in model 4. The result in model 5 is in contrast with model 2 where it indicates significant variables of urbanisation, life expectancy and secondary education level. Despite of this result, model 2 is superior than the other 4 models as the diagnostic test BPLM supported pooled OLS is preferred and robust pooled OLS has improved the heterogeneity and serial correlation problem.

V CONCLUSION

In this study, the determinants of life insurance consumption in the perspective of economics and demographic are to be examined. The results show that in ASEAN countries, the factors that influence life insurance consumption are income (economics factor), youth dependency ratio and tertiary education level (demographic factors). In contrary, economics factors such as inflation and real interest rate in addition to demographic factors such as urbanization, life expectancy and secondary education level do not indicate strong association with demand for life insurance.

As the ASEAN countries are developing towards achieving developed countries, the income per capita will need to improve to accomplish this goal. Since life insurance had been proven with its benefits that enable the individual to safeguard the uncertainty in risks, and income has positive association with life insurance, insurance companies could globalise their markets in ASEAN countries. This may increase the sales of life insurance and provide profit to the insurance companies. The indirect result will further assist the countries in ASEAN to continue growing with the better social return provided by insurance

product. Furthermore, the study on the difference of secondary and tertiary education towards demand for life insurance is investigated. The result shows that secondary education has no influence towards life consumption but tertiary education results reverse outcome towards life consumption.

Therefore, it is recommended that the students in ASEAN countries should be exposed to the knowledge of insurance in increasing their awareness on the crucial roles of insurance to the individuals and economics. This will indirectly improve the family to safeguard their children future if they purchase life insurance product.

In a nutshell, tertiary education in ASEAN countries may become the key agents to improve future economics with better income and social return with the support of life insurance in the market to achieve AEC blueprint of “A Resilient, Inclusive, People-Oriented, and People-Centred ASEAN”.

REFERENCES

- Alhassan, A. L. & Fiador, V. (2014). Insurance-growth Nexus in Ghana: An Autoregressive Distributed Lag Bounds Cointegration Approach. *Review of Development Finance*, 4, 83-96.
- ASEAN (2015). ASEAN Economic Community. Retrieved from: <http://www.asean.org/asean-economic-community/>
- Baltagi, B.H. (2005). *Econometric Analysis of Panel Data*, John Wiley & Sons Ltd, Chichester.
- Beck, T. & Webb, I. (2003). Economic, Demographic, Institutional Determinants Of Life Insurance Consumption Across Countries. *The World Bank Economic Review*, 17(1), 51-88.
- Browne, M.J. and Kim, K. (1993). An international analysis of life insurance demand. *Journal of Risk and Insurance*, 60(4):616-34.
- Gujarati, D., N. and Porter, D., C. (2009). *Basic econometrics* (5th ed.). Boston: McGraw-Hill.
- Huebner, S.S. (1916). *Life Insurance*, D. Appleton and Co., New York.
- Hwang, T. and Gao, S. (2003). The determinants of the demand for life insurance in an emerging economy –the case of China. *Managerial Finance* 29(5/6): 82-96.
- Lee, J. W. and Park, C. Y. (2009). Global financial turmoil: impact and challenges for Asia's financial systems. *Asian Economic Papers*, 8(1):9- 40.
- Li, D., Moshirian, F., Nguyen, P. and Wee, T. (2007). The demand for life insurance in OECD countries. *Journal of Risk and Insurance*, 74(3):637-52.
- Outreville, J. F. (1990). The economic significance of insurance markets in developing countries. *Journal of Risk and Insurance*, 487-498.
- Outreville, J. (1996). Life Insurance Markets in Developing Countries. *The Journal of Risk and Insurance*, 63(2), 263-278.
- Outreville, J. F. (1999). Financial development, human capital and political stability. *United Nations Conference on Trade and Development*.
- Outreville, J.F. (2011). The relationship between insurance growth and economic development: 80 empirical papers for a review of the literature, *ICER Working Paper*, No. 12/2011.
- Outreville, J.F. (2015). The Relationship Between Relative Risk Aversion And The Level Of Education: A Survey And Implications For The Demand For Life Insurance. *Journal of Economic Surveys*, 29(1), 97-111.
- Pissarides, C.A. (1980). The wealth-age relation with life insurance. *Economica*, 47(188):451-457.
- Sen, S. Madheswaran, S. (2013). Regional determinants of life insurance consumption: evidence from selected Asian economies. *Asian Pacific Economic Literature*, 1, 86-103.

- Treerattanapun, A. (2011). The impact of culture on non-life insurance consumption. Paper presented at Wharton Research Scholars Project, The University of Pennsylvania.
- Truett, D.B. and Truett, L.J. (1990). The demand for life insurance in Mexico and the United States: a comparative study. *Journal of Risk and Insurance*, 57(2):321-8.
- Ward, D. and Zurbrugg, R. (2002) Law, politics and life insurance consumption in Asia. *Geneva Papers on Risk and Insurance* 27(3): 395-412.
- Yuan, C., & Jiang, Y. (2015). Factors affecting the demand for insurance in China. *Applied Economics*, 47(45), 4855-486

Lexicon-Based and Immune System Based Learning Methods in Twitter Sentiment Analysis

Hamidah Jantan, Fatimatul Zahrah Drahman, Nazirah Alhadi, and Fatimah Mamat

*Universiti Teknologi MARA (UiTM) Terengganu, Malaysia,
hamidahjtn@tganu.uitm.edu.my, {fatimahtuldh,nazirah,fatimahm}@yahoo.com*

ABSTRACT

Nowadays, there are increasingly numbers of studies on seeking ways to mine Twitter for sentiment analysis. Machine learning approach such as immune system based learning methods is an alternative way for sentiment classification. This method is centered on prominent immunological theory as computation mechanisms that emulate processes in biological immune system in achieving higher probability for pattern recognition. The aim of this article attempts to study the potential of this method in text classification for sentiment analysis. This study consists of three phases; data preparation; classification model development using three selected Immune System based algorithms i.e. Negative Selection algorithm (NSA), Clonal Selection algorithm (CSA) and Immune Network algorithm (INA); and model analysis. As a result, NSA algorithm proposed slightly high accuracy in experimental phase and that would be considered as the potential classifiers for Twitter sentiment analysis. In future work, the accuracy of proposed model can be strengthened by comparative study with other heuristic based searching algorithms such as genetic algorithm, ant colony optimization, swam algorithms and etc.

Keywords: Immune system, lexicon, sentiment classification, twitter messages.

I INTRODUCTION

Micro blogging platforms such as Twitter used by many companies and media organizations to know what people think and feel about their products and services. Given the character limitation on tweets, it deals with explicit messages that contain valuable sentiments for future decision making. Sentiment analysis in natural language processing (NLP) field is ranging from document, sentence, and aspect level analysis to learning the polarity of words and phrases in text. Twitter as social media deal with short message that has limited number of characters but contains valuable sentiment for future decision making in many area. Twitter sentiment analysis commonly used in product review, stock market analysis, news articles, political debates and etc. (Alexander & Paroubek, 2010; Balahur &

Steinberger, 2009; Medhat et al., 2014; Tumasjan et al., 2010; Xiaodong Li et al., 2014). In sentiment analysis, there are four main tasks i.e. sentiment identification, feature selection, classification and polarity. Sentiment classification will determine the end result of sentiment in text analysis. As an example, sentiment classification in Twitter messages focus on sentence-level analysis in order to identify the view point(s) of underlying sentiment in text such as positive, negative and neutral (Pang & Lee, 2004). In sentiment classification, there are three major classification techniques can use for sentiment analysis i.e. machine learning that focus on linguistic features, lexicon-based relies on sentiment lexicon and hybrid approaches (Choi et al., 2009; Medhat et al., 2014; Pang & Lee, 2004). Machine learning approach has been widely used for sentiment analysis in order to reduce the high-dimensional feature space feature selection in traditional approach by eliminating the noisy and irrelevant features; and their ability towards global optimization in classifier construction (Agarwal & Mittal, 2015; Medhat et al., 2014).

Immune systems based learning method is known as soft computing paradigm used in machine learning. This approach inspired by the human immune system that elicits theories which can act as an inspiration for computer-based solutions as alternative approach to solve computational problems (Azadeh et al., 2014; Hunt & Cooke, 1996; Sarafijanovic & Boudec, 2005). Artificial Immune Systems (AIS) has led to the development of numerous classification models in various areas such as pattern recognition, fault detection, computer security, data mining, engineering and computer applications (Venkatesan et al., 2013). Due to the uniqueness of self-recognition ability stimulated by the biological immune system, this technique is widely used in pattern recognition by classifying self or non-self as detectors in classification task. In this study, three selected AIS based algorithms i.e. Negative Selection algorithm (NSA), Clonal Selection algorithm (CSA) and Immune Network algorithm (INA) are used as recognition mechanism by classifying sentiment in text analysis. The rest of this paper is organized as follows: the second section discusses the related work in sentiment mining and AIS algorithms and application, the third section describes the

experiment setup conducted in this study and, the fourth section discusses the results and discussions. Finally, the paper ends with the fifth section where the concluding remarks and future research directions are identified.

II RELATED WORK

A. Sentiment Analysis

Nowadays, sentiment analysis is among the key emergent technologies to navigate the huge amount of online content regarding on people opinion in product review, political view, stock market analysis, news article and etc. (Alexander & Paroubek, 2010; Kucuktunc et al., 2012; Paltoglou & Thelwall, 2012; C. Tan et al., 2011). The ability to extract opinion or sentiment from online sources can provide valuable information about people's views on various topics that are beneficial for future planning. Sentiment analysis identified the sentiment expressed in a text then analyses it to find opinions, identify the sentiments and to classify their polarity as shown in Figure 13. (Choi et al., 2009; Medhat et al., 2014; Pang & Lee, 2004). Sentiment classification is a central task that has three main classification levels i.e. document-level aims to classify an opinion document as expressing a positive or negative opinion; sentence-level focus to classify sentiment in each sentence whether subjective or objective then determine whether it is positive or negative; and aspect-level aims to classify the sentiment with respect to the specific aspects of entities.

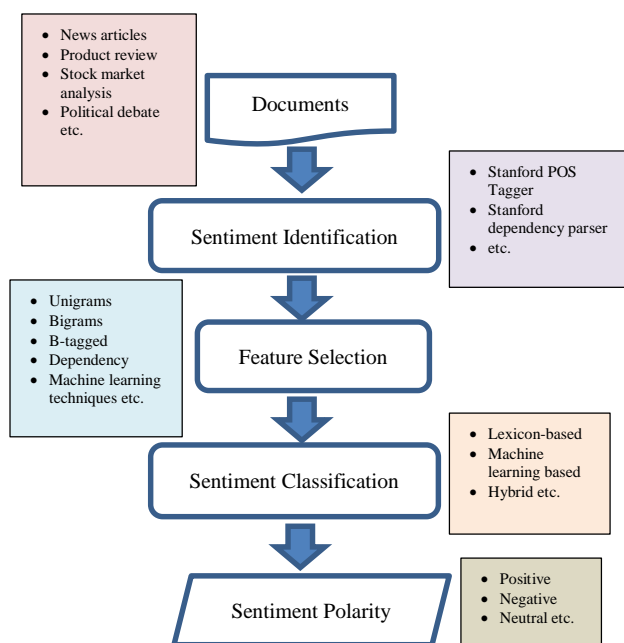

Figure 13. Fundamental of Sentiment Analysis

Sentiment classification techniques categorized into three approaches i.e. lexicon-based; machine learning; hybrid approaches (Medhat et al., 2014). Lexicon-based approach relies on sentiment lexicon which is a collection of precompiled sentiment terms that known as manual-based, dictionary-based and corpus-based collections. This approach uses statistical or semantic methods to find sentiment polarity in text analysis. There are many applications that use this approach such as Arabic Twitter corpus for subjectivity (Refaee & Rieser, 2014); Indian general election using context rules (Singhal et al., 2015); news impact on stock market (Xiaodong Li et al., 2014) and many others.

Machine learning approach uses linguistic features in supervised learning and unsupervised learning. Supervised learning deals with a large labeled training documents and unsupervised learning for unlabeled training documents for classification task. The common techniques used in supervised learning are decision tree, linear-based (Support Vector machine and Neural Network), rule-based and probabilistic classifier (Naïve Bayes, Bayesian Network and Maximum entropy). Support vector machine (SVM) is proven as high performance and robust methods as classifier in previous works (Agarwal & Mittal, 2015; Joachims, 2005; Mudinas et al., 2012; S. Tan & Zhang, 2008; Zhang et al., 2011). Besides that, Bayesian naïve methods are known as the most efficient and effective inductive learning algorithms for machine learning (Agarwal & Mittal, 2015; Dinu & Iuga, 2012; McKaughan et al., 2011). Recently, bio-inspired algorithms for classification attract attention in this area due to the ability in propose high accuracy in classification (Akhmedova et al., 2014; Puteh et al., 2013; Samsudin et al., 2013).

Hybrid approach combines both approaches where sentiment lexicons playing a key role in sentiment analysis. As example, this approach used in combining lexicon-based and learning-based methods for sentiment analysis (Akhmedova et al., 2014; Khan et al., 2015; Mudinas et al., 2012; Zhang et al., 2011). In this approach, lexicon-based approach focus on sentiment feature selection and machine learning- based approach focus on sentiment classification. Besides that, other techniques from those categories also been used in sentiment analysis such as Formal Concept Analysis (FCA) is a mathematical approach for structuring, analyzing and visualizing data, Fuzzy Formal Concept Analysis (FFCA) to conceptualize documents into a more abstract form of concepts and etc.(Medhat et al., 2014)

Twitter Sentiment Analysis

Nowadays, in the emerging social media, more and more people are expressing their likes and dislikes sentiments towards different subjects about current affairs on blogs, micro-blogs and social networking sites such as Twitter, Facebook and etc. Analyzing these expressions of short colloquial text can yield vast information about the behavior of the people that can be helpful in many. There are many studies on Twitter sentiment analysis to handle these issues especially in product review, stock market analysis, political debates and many others (Alexander & Paroubek, 2010; Balahur & Steinberger, 2009; Medhat et al., 2014; Tumasjan et al., 2010; Xiaodong Li et al., 2014). Their focus is to determine the polarity of the Twitter sentiment analysis using either lexicon-based, machine-based, hybrid or other method in sentiment classification (Kontopoulos et al., 2013; Kouloumpis et al., 2011; Singhal et al., 2015).

B. Immune Based Learning System

Bio-inspired algorithms stimulate human immune system known as Artificial Immune System (AIS). This technique inspired by the immunology immune function, principles and models to solve complex problem and implements a learning technique for natural defense mechanism that learns about foreign substances (Dasgupta, 2006; Hunt & Cooke, 1996). There are three common algorithms in AIS i.e. Negative selection algorithm (NSA), clonal selection algorithm (CSA) and artificial immune network (AiNet) algorithm.

Clonal Selection Algorithm

The clonal selection algorithm is a class of algorithms inspired by the clonal selection theory of acquired immunity that describe how B and T lymphocytes improve the reaction of antigen which is called as affinity maturation. The clonal selection theory in an immune system is used to clarify the basic reaction of the adaptive immune system to an antigenic stimulus. The theory is based on the idea that only cells capable of recognizing an antigen will proliferate (Berna & Sadan, 2011). Its main idea is the antigen can selectively react with the antibodies, which are native production and spread on the cell surface in the form of peptides. When an antigen is discovered, those antibodies that best recognize an antigen will proliferate by cloning.

Clonal selection operation has the ability to combine the global search with local search. The global optimum can be easily obtained through a series of operations including clone, mutation, and selection

(Liu et al., 2009). Figure 2 shows the process flow for Clonal selection algorithm (CSA) in classification process to detect antigen (Castro & Timmis, 2003). Where P is a candidate solution, M is a memory set, P_r is the remaining of population that indicates $P = P_r + M$, P_n is best individual of population, C is temporary population of clones, C^* is matured antibody population and N_d is replace d antibodies by novel ones (diversity introduction), the lower affinity cells have higher probabilities of being replaced.

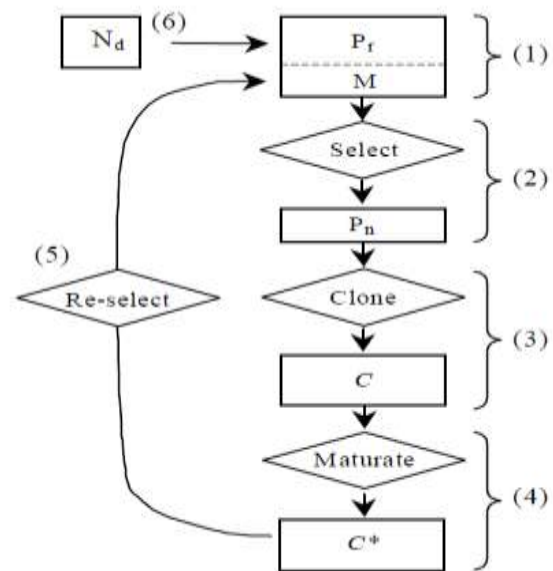

Figure 14. Clonal Selection Algorithm (CSA)

Negative selection algorithm

The Negative Selection Algorithm (NSA) is an immunology-inspired algorithm for anomaly detection application. This algorithm has been implemented with different pattern representations and various matching rules and successfully applied to a broad range of problems (Hou & Dozier, 2006).

NSA is an approach to anomaly detection using negative detectors, was originally proposed by Forrest, which models the clonal deletion process in the natural immune system to prevent autoimmunity (Hou & Dozier, 2006). The NSA generates random detectors and removes the ones that detect self-patterns, which results in a collection of detectors that potentially detect non self-patterns. Classification is performed by generating detectors that match none of the negative examples, and these detectors are then matched against the elements to be classified and a large number of detectors may be required for acceptable sensitivity, or finding detectors that match none of the negative examples may be difficult (Li et al., 2010). Figure 3 shows the

process flow of NSA for generation and detection in classification process

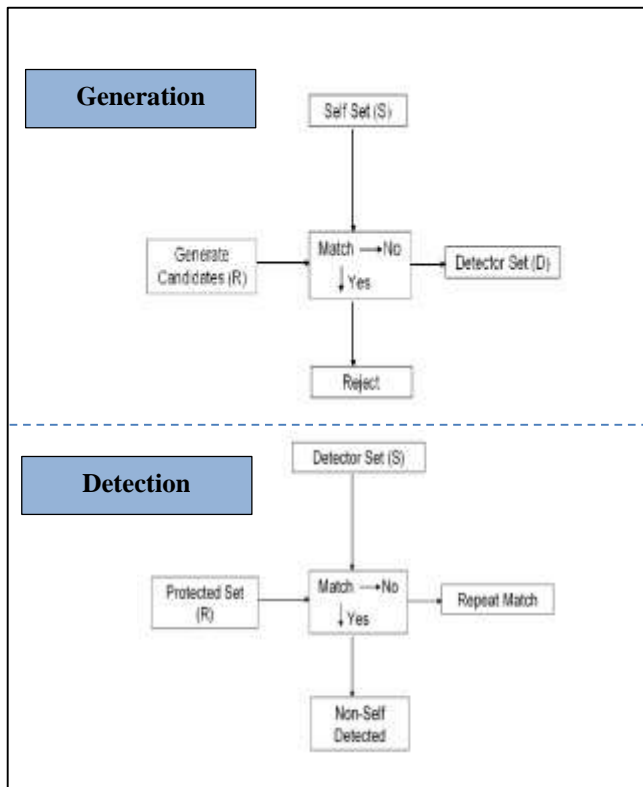

Figure 3. Fundamental of Negative Selection Algorithm

Artificial Immune Network

Artificial Immune Network (AiNet) is a bio-inspired computational model that uses ideas and concepts from the immune network theory, mainly the interactions among B cells (stimulation and suppression), and the cloning and mutation process (Fran et al., 2005; Galeano et al., 2005). The immune network theory was suggested by Jerne, as a way to describe the memory and learning capabilities exhibited by the immune system. AiNet algorithm focus on the network graph structures involved where antibody producing cells represent the nodes and the training algorithm involves growing or pruning edges between the nodes based on affinity as shown in Figure 4.

AiNet algorithm has been used to solve the computer security against computer viruses which disrupt the normal usage of the network. (Chandrasekaran & Murugappan, 2008). Besides that, another research using AiNet is used for mobile ad hoc networks to detect the node misbehavior in mobile ad hoc network using DSR (Sarafijanovic & Boudec, 2005). AiNet used for multimodal function optimization on dynamic environment to deal with the time-varying fitness function with the challenging benchmark problems in static

multimodal optimization are considered to validate the new proposal (Fran et al., 2005).

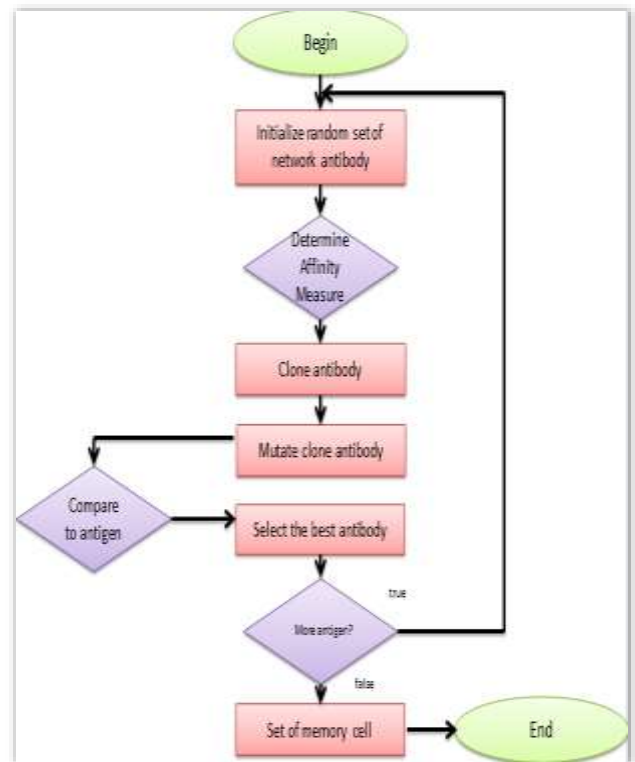

Figure 4. Artificial Immune Network Algorithm (AiNet)

III RESEARCH METHOD

Sentiment analysis in this study has four main phases using lexicon-based and immune system based approaches. Figure 5 show the process flow involved in this study.

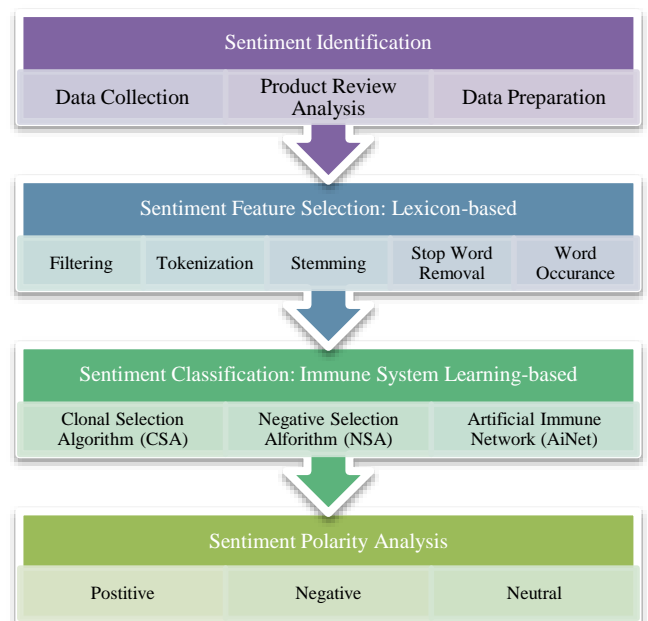

Figure 5. Experiment Phase on Twitter Sentiment Analysis

The first phase is sentiment identification contains data collection, product review analysis and data preparation activities. Twitter dataset on hand phone product review that contain 600 Twitter messages are used for the case study. The second phase is sentiment feature selection using lexicon-based approach that contains filtering, tokenization, stemming, stop word removal and word occurrence analysis to prepare a group of word (Bag of Words (BOWs)). Immune system based learning approach is used as sentiment classification method in third phase. Three common algorithms in AIS are used in this process i.e. Clonal Selection Algorithm (CSA), Negative Selection Algorithm (NSA) and Artificial Immune Network (AiNet). Dataset is divided into 480 as training dataset and 120 as testing dataset in learning process. Sentiment polarity analysis in the fourth phase is determined by the accuracy of correctly classified in testing data via proposed classification model for each algorithm.

IV RESULT ANALYSIS

In this study, the lexicon-based approach is used in sentiment feature selection process in order to prepare the collection of word (BOW) for the dataset. **Error! Reference source not found.** shows the sample of clean data by filtering, stemming and stop word removal processes in this phase. The next step is to prepare the antibody by identify the sentiment (positive, negative or neutral). The clean data than categorized according to sentiment

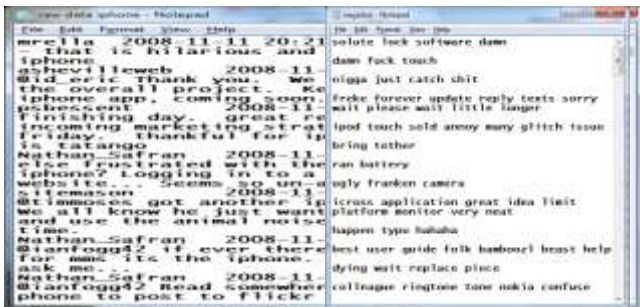

Figure 6. Sample of Datasets

identified from selected dictionary. As an example, in NSA algorithm training phase, a set of detectors will be generated as non-self.

Table 7. Sample of Detectors from NSA Algorithm

Positive Detector	Neutral Detector	Negative Detector
positive,attention,2	neutral,phones4u,2	negative,solution,1
positive,user,6	neutral,agree,2	negative,lock,1
positive,adobe,3	neutral,deal,3	negative,software,4
positive,free,8	neutral,stock,2	negative,damn,6
positive,pretty,6	neutral,guardian,1	negative,fuck,4
positive,cool,13	neutral,open,1	negative,touch,6
positive,extreme,1	neutral,process,3	negative,nigga,1
positive,slick,1	neutral,develop,9	negative,catch,1
positive,bloomberg,1	neutral,twitter,13	negative,shit,3
positive,bring,2	neutral,application,48	negative,freke,1

positive,just,16 neutral,shorten,1 negative,forever,2

Table 7 shows the sample of detector generated by NSA algorithm for positive, neutral and negative detectors. The accuracy of proposed classification model in sentiment classification using three selected algorithms determined by the percentage of correctly classified in testing dataset. Table 8 shows the result analysis for the selected AIS algorithms in sentiment classification phase.

Table 8. Immune System Based Learning Method Classification Analysis

AIS Algorithm	Negative Selection	Clonal Selection	Artificial Immune Network
Learning activities	Generation, detection, matching	Affinity analysis, cloning, mutation	Cloning, mutation, affinity analysis, suppress network
Classifier	Set of detector	Highest affinity list of word	List of detectors with highest affinity
Correctly Classified	76	72	67
Incorrectly Classified	44	48	53
Accuracy	63.33%	60.00%	55.83%

In this study, the accuracy for AIS selected algorithms is between 56 to 63%. The results show that the NSA algorithm has slightly higher accuracy as compared to CSA and AiNet algorithms. The accuracy is considered acceptable for the dataset and may be in future need some enhancements for better accuracy in classification process. As an example of application, the prototype system that applied selected AIS classification model for sentiment analysis is shown Figure .

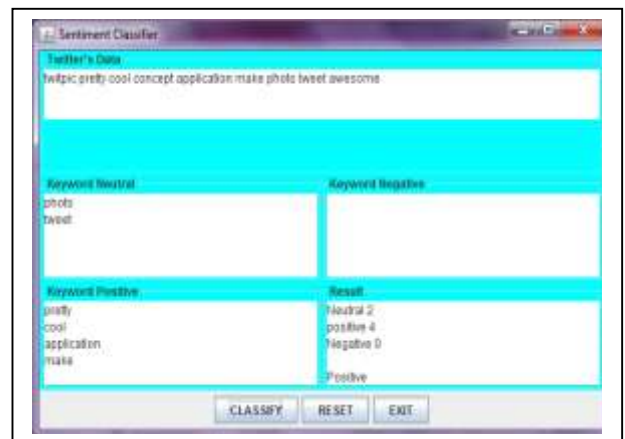

Figure 7. Prototype System for Sentiment Analysis

V CONCLUSION

In this study, lexicon-based approach is used in sentiment feature selection process and machine learning approach that used for sentiment classification. AIS algorithm as immune system based learning is proposed method for sentiment classification. As a result, NSA algorithm produced a little bit higher accuracy compared to CSA and AiNet algorithm. In future work, the comparative study using other machine learning technique such as bio-inspired algorithm, nature-based algorithm and many other. Besides that, other techniques for data preprocessing such as back-forward stemming algorithm and porter algorithm would be considered as alternative approach in sentiment feature selection process. This would give a new direction for sentiment classification. As a conclusion, the ability to obtain new understanding of AIS algorithm in sentiment classification will lead to the imperative contribution in sentiment analysis area.

REFERENCES

- Agarwal, B., & Mittal, N. (2015). Machine Learning Approach for Sentiment Analysis *Prominent Feature Extraction for Sentiment Analysis* (Vol. 2, pp. 21-45). Switzerland: Springer International Publishing
- Akhmedova, S., Semengin, E., & Sergienko, R. (2014). *Automatically Generated Classifier for Opinion Mining with Different Term Weighting Schemes*. Paper presented at the 11th International Conference on Informatics in Control, Automation & Robotics (ICINCO), Vienna, USA.
- Alexander, P., & Paroubek, P. (2010). *Twitter as a Corpus for Sentiment Analysis and Opinion Mining*. Paper presented at the *Proceedings of the Seventh International Conference on Language Resources and Evaluation* Valletta, Malta.
- Azadeh, A., Taghipour, M., Asadzadeh, S. M., & Abdollahi, M. (2014). Artificial immune simulation for improved forecasting of electricity consumption with random variations. *Electrical Power and Energy Systems*, 55, 205 – 224.
- Balahur, A., & Steinberger, R. (2009). *Rethinking Sentiment Analysis in the News: from Theory to Practice and back*. Paper presented at the Proceeding of the 1st Workshop on Opinion Mining and Sentiment Analysis.
- Berna, H. U., & Sadan, K.-k. (2011). A Review of Clonal Selection Algorithm and Its Applications. *The Artificial Intelligence Review*, 36(2), 117-138.
- Castro, L. N. d., & Timmis, J. I. (2003). Artificial Immune Systems as A Novel Soft Computing Paradigm. *Soft Computing* 7(8), 526-544. doi: 10.1007/s00500-002-0237-z
- Chandrasekaran, S., & Murugappan, C. D. A. (2008). *An Artificial Immune Networking Using Intelligent Agents*. Paper presented at the Proceedings of the World Congress on Engineering London.
- Choi, Y., Kim, Y., & Myaeng, S.-H. (2009). *Domain-specific sentiment analysis using contextual feature generation*. Paper presented at the Proceedings of the 1st international CIKM workshop on Topic-sentiment analysis for mass opinion, Hong Kong, China.
- Dasgupta, D. (2006). Advances in Artificial Immune Systems. *Computational Intelligence Magazine, IEEE* 1(4), 40-49.
- Dinu, L. P., & Iuga, I. (2012). *The Naive Bayes Classifier in Opinion Mining: In Search of The Best Feature Set*. Paper presented at the 3th international conference on Computational Linguistics and Intelligent Text Processing, New Delhi, India.
- Fran, F. O. d., Zuben, F. J. V., & Castro, L. N. d. (2005). *An Artificial Immune Network for Multimodal Function Optimization on Dynamic Environments*. Paper presented at the *Proceedings of the 2005 conference on Genetic and evolutionary computation*, Washington DC, USA.
- Galeano, J. C., Veloza-Suan, A., & Gonzalez, F. A. (2005). *A comparative analysis of artificial immune network models*. Paper presented at the *Proceedings of the 2005 conference on Genetic and evolutionary computation*, Washington DC, USA.
- Hou, H., & Dozier, G. (2006). *An Evaluation of Negative Selection Algorithm with Constraint-based Detectors*. Paper presented at the Proceedings of the 44th annual Southeast regional conference, Melbourne, Florida, USA.
- Hunt, J., & Cooke, D. (1996). Learning using An Artificial Immune System. *Journal or Network and Computer Applications*, 19, 189-212.
- Joachims, T. (2005). Text Categorization with Support Vector Machines: Learning with Many Relevant Features. *Machine Learning: ECML-98*, 137-142.
- Khan, A. Z. H., Atique, M., & Thakare, V. M. (2015). Combining Lexicon-based and Learning-based Methods for Twitter Sentiment Analysis. *Special Issue of International Journal of Electronics, Communication & Soft Computing Science and Engineering*, 1, 89-75.
- Kontopoulos, E., Berberidis, C., Dergiades, T., & Bassiliades, N. (2013). Ontology-based Sentiment Analysis of Twitter Posts. *Expert Systems with Applications*, 40, 4065–4074.
- Kouloumpis, E., Wilson, T., & Moore, J. (2011). *Twitter Sentiment Analysis: The Good the Bad and the OMG!* Paper presented at the The Fifth International AAI Conference on Weblogs and Social Media, Barcelona, Spain.
- Kucuktunc, O., Cambazoglu, B. B., Weber, I., & Ferhatosmanoglu, H. (2012). *A Large-Scale Sentiment Analysis for Yahoo! Answers*. Paper presented at the 5th ACM International conference, New York, USA.
- Li, M., kiewicz, & Textor, J. (2010). *Negative Selection Algorithms without Generating Detectors*. Paper presented at the "Proceedings of the 12th annual conference on Genetic and evolutionary computation", Portland, Oregon, USA.
- Liu, R., Sheng, Z., & Jiao, L. (2009). *Gene transposon based clonal selection algorithm for clustering*. Paper presented at the "Proceedings of the 11th Annual conference on Genetic and evolutionary computation", Montreal, Canada.
- McKaughan, D. C., Heath, Z., & McClain, J. T. (2011). *Using a text analysis and categorization tool to generate Bayesian belief networks for use in cognitive social simulation from a document corpus*. Paper presented at the Proceedings of the 2011 Military Modeling & Simulation Symposium, Boston, Massachusetts.
- Medhat, W., Hassan, A., & Korashy, H. (2014). Sentiment Analysis Algorithms and Applications: A Survey. *Ain Shams Engineering Journal*, 5, 1093-1113.
- Mudinas, A., Zhang, D., & Levene, M. (2012). *Combining Lexicon and Learning based Approaches for Concept-Level Sentiment Analysis*. Paper presented at the The First International Workshop on Issues of Sentiment Discovery & Opinion Mining, New York, USA.

- Paltoglou, G., & Thelwall, M. (2012). Twitter, MySpace, Digg: Unsupervised Sentiment Analysis in Social Media. *ACM Transactions on Intelligent Systems and Technology*, 3(4), 1-19.
- Pang, B., & Lee, L. (2004). *A Sentimental Education: Sentiment Analysis using Subjectivity Summarization Based on Minimum Cuts*. Paper presented at the Proceedings of the 42nd Annual Meeting on Association for Computational Linguistics, Barcelona, Spain.
- Puteh, M., Isa, N., Puteh, S., & Redzuan, N. A. (2013). *Sentiment Mining of Malay Newspaper (SAMNews) Using Artificial Immune System*. Paper presented at the The World Congress on Engineering London, UK.
- Refaee, E., & Rieser, V. (2014). *An Arabic Twitter Corpus for Subjectivity and Sentiment Analysis*. Paper presented at the Ninth International Conference on Language Resources and Evaluation, Reykjavik, Iceland.
- Samsudin, N., Puteh, M., Hamdan, A. R., & Nazri, M. Z. A. (2013). *Immune Based Feature Selection for Opinion Mining*. Paper presented at the The World Congress on Engineering, London, UK.
- Sarafijanovic, & Boudec, L. (2005). An Artificial Immune System Approach with Secondary Response for Misbehavior Detection in Mobile Ad hoc Networks. *Neural Networks, IEEE Transactions on*, 16(5), 1076-1087.
- Singhal, K., Agrawal, B., & Mittal, N. (2015). Modeling Indian General Elections: Sentiment Analysis of Political Twitter Data. *Information Systems Design and Intelligent Applications*, 469-477.
- Tan, C., Lee, L., Tang, J., Jiang, L., Zhou, M., & Li, P. (2011). *User-Level Sentiment Analysis Incorporating Social Networks*. Paper presented at the Proceedings of the 17th ACM SIGKDD international conference on Knowledge discovery and data mining, San Diego, California, USA.
- Tan, S., & Zhang, J. (2008). An Empirical Study of Sentiment Analysis for Chinese Documents. *Expert Systems with Applications*, 34, 2622-2629.
- Tumasjan, A., Sprenger, T., Sandner, P., & Welpe, I. (2010). *Predicting Elections with Twitter: What 140 Characters Reveal about Political Sentiment*. Paper presented at the International AAAI Conference on Weblogs and Social Media, Germany.
- Venkatesan, S., Baskaran, R., Chellappan, C., Vaish, A., & Dhavachelvan, P. (2013). Artificial immune system based mobile agent platform protection. *Computer Standards & Interfaces*, 35(4), 365 – 373.
- Xiaodong Li, Haoran Xie, Li Chen, Jianping Wang, & Xiaotie Deng. (2014). News Impact on Stock Price Return via Sentiment Analysis. *Knowledge-Based Systems*, 69, 14-23.
- Zhang, L., Ghosh, R., Dekhil, M., Hsu, M., & Liu, B. (2011). Combining Lexicon-based and Learning-based Methods for Twitter Sentiment Analysis. HP Laboratories: Hewlett-Packard Development Company.

A Comparative Study of Service-Oriented Architecture Maturity Model

Mohd Hamdi Irwan Hamzah^{1,2}, Fauziah Baharom², and Haslina Mohd²

¹Universiti Tun Hussein Onn Malaysia (UTHM), Malaysia, hamdi@uthm.edu.my

²Universiti Utara Malaysia (UUM), Malaysia, {fauziah, haslina}@uum.edu.my

ABSTRACT

Service-oriented Architecture (SOA) maturity model is a benchmark for evaluating and assessing the maturity of SOA adoption. Several of SOA maturity models have been constructed by the academia and industry. However, these models contradict with each other in determining “what” need to be assessed in SOA adoption. Therefore, the aims of this study is to review and compare the existing SOA maturity models that were commonly referred such as SOAMM, SIMM, CSOAMM, Inaganti’s Model, iSOAMM, Welke’s Model and SOASMM in order to determine which model should be enhanced to reflect the true definition of SOA. The findings implies that the existing models have their own strengths and weaknesses and based on these findings, this study identify that Welke’s model is the most suitable model that should be enhanced. This study has successfully analyze the existing models and identify an issue that deserve future investigation such as the need to provide two dimensional evaluations for both IT benefits and business benefits and the need to improve the evaluation processes in the SOA maturity model.

Keywords: Service-Oriented Architecture, Service-Oriented Architecture Maturity Model, SOA, SOAMM.

I INTRODUCTION

Nowadays, we have seen the migration of legacy systems towards Service-Oriented Architecture (SOA). SOA is an architectural style for developing software systems that use accessible services in a network (Papazoglou, 2008). It is a paradigm for business and Information Technology (IT) people that guide and integrate distributed capabilities of services under different ownership regardless of different platforms, operating system and languages (Baghdadi, 2014; Kontogiannis et al., 2007). The benefits of this migration include improving reliability, reducing development cost and the ability of reuse. Many organizations in several different domains have successfully adopted SOA especially in healthcare (Ganapathy, Priya, Priya, Prashanth, & Vaidehi, 2013), supply chain management (Cheng, Law, Bjornsson, Jones, & Sriram, 2010) and e-government portal (Sedek & Omar, 2013). Yet, there

are still many more that have been unwilling to adopt SOA (Feuerlicht, 2007). This reluctance might due to immaturity of SOA practices (Ciganek, Haines, & Haseman, 2009).

The SOA adoption involves a transformation process that affects the social and technological structure of organizations (Sutawijaya & Chiok, 2010). SOA also has been touted as “the next big thing” for designing, implementing and deploying large scale service provision software systems (Konigsberger, Silcher, & Mitschang, 2014). Still, many SOA efforts were failed to meet the business objectives which is a problem that still exists today (Konigsberger et al., 2014). Thus, in order to solve this problem, previous industry and academia had introduced SOA maturity models which can be used to provide a roadmap for successful SOA adoption (Ameller et al., 2015; Söderström & Meier, 2007).

SOA maturity model can be used to control and to measure the progress of SOA adoption. However, previous models contradict with each other in determining “what” need to be assessed in SOA adoption. Therefore, the focus of this study is to review and compare the existing SOA maturity models in order to determine which model can be enhanced to reflect the true definition of SOA. The structure of this paper is organized as follows: section 2 and 3 provides an overview of SOA adoption and SOA maturity model. Section 4 and 5 presents the findings and discussions. Section 6 concludes the study with a brief summary.

II OVERVIEW OF SOA ADOPTION

There have been many definition of SOA from different perspectives but still there is no common understanding of what SOA is (Erl, 2005). However, this study has found that they all shared some common principles where majority of researchers have stated that as to truly achieved the SOA adoption concept, the organization should treat and view SOA from both IT benefits and business benefits (Baghdadi, 2014; Borges & Mota, 2007; Derler & Weinreich, 2007). The benefits of adopting SOA for both parties is that business people can achieved the flexibility and agility of business processes whereas IT people can take advantage of SOA characteristics such as reuse, composition of application and integration of data to develop a new application. Furthermore, Joachim, Beimborn, Hoberg and Schlosser (2009)

stated that the term adoption refers to the decision to make full use of an innovation. The adoption of SOA also can lead to a major transformation of an organizations IT architecture (Joachim et al., 2009). Next section discuss on SOA maturity model which can be used to guide the adoption of SOA.

III SOA MATURITY MODEL

A SOA maturity model is a model that was used to clarify and provide common definition of SOA inside an organization (Meier, 2006; Sonic Software, AmberPoint, BearingPoint & Systinet, 2005). The most often mentioned benefit of SOA maturity models is that they can help to guide the adoption of SOA (Meier, 2006). Furthermore, these benefits of adopting SOA in organization can be distinguish into IT benefits and business benefits (Baskerville, Cavallari, Hjort-Madsen, Pries-Heje, & Sorrentino, 2005; Becker, Buxmann, & Widjaja, 2009; Joachim, 2011; Yoon & Carter, 2007). Therefore, this study discuss on the SOA maturity models that were commonly referred by the researchers such as SOAMM (Sonic Software, AmberPoint, BearingPoint, & Systinet, 2005), SIMM (Kreger et al., 2009), CSOAMM (Söderström & Meier, 2007), Inaganti's Model (Inaganti & Aravamudan, 2007), iSOAMM (Rathfelder & Groenda, 2008), Welke's Model (Welke, Hirschheim, & Schwarz, 2011) and SOASMM (Kassou & Kjiri, 2012). Next section provides details discussion on each model.

A. SOAMM

The SOA Maturity Model (SOAMM) (Sonic Software, AmberPoint, BearingPoint, Systinet, 2005) was published in 2005. The model was created based on the response of nearly 2000 developers, architects and industry analyst reports that showed a successful adoption of SOA. SOAMM is intended to prepare organizations for successful SOA adoption, to set a SOA vision and to measure the progress. SOAMM consist of five maturity levels as shown in Figure 1: Initial services, architected services, business services or collaborative services, measured business services and optimized business services.

Maturity Level	Evaluation Dimension				
Initial Service	Prime Business Benefits	Scope	Critical Technology Success Factors	Critical People & Organizational Success Factors	Selected Relevant Standard
Architected Services					
Business Services					
Collaborative Services					
Measured Business Services					
Optimized Business Services					

Figure 1. SOAMM (Sonic Software, AmberPoint, BearingPoint & Systinet, 2005).

As shown in Figure 1, SOAMM aligned their maturity levels across a set of evaluation dimensions such as prime business benefits, scope, critical technology success factors, critical people and organizational success factors and selected relevant standards. SOAMM also view their maturity model in a way to increase the positive impact which SOA adoption can have from a business perspective. This can be seen by each of the maturity levels that try to assess and increase the levels of business benefits from the adoption of SOA. Based on Figure 1, the prime business benefits such as functionality, cost effectiveness, business responsiveness, business transformation and business optimization can be achieved as the level of maturity increase.

B. SIMM

The Service Integration Maturity Model (SIMM) (Kreger et al., 2009) was published by IBM in 2005. IBM created a maturity model in order to provide a ways to access a corporation's service maturity. The model consists of seven levels of maturity presented in Figure 2: silo, integrated, componentized, simple services, composite service, virtualized services, and dynamically reconfigurable services.

Maturity Level	Evaluation Dimension					
Silo	Business view	Governance & organization	Methods	Application	Architecture	Information
Integrated						
Componentized						
Service						
Composite Services						
Composite Services						
Dynamically reconfigurable Services						
					Infrastructure & management	

Figure 2. SIMM (Kreger et al., 2009).

SIMM is a maturity model that used services as major structuring component to increase business flexibility. They link their maturity levels with the desired business outcomes across different types of evaluation dimensions. SIMM also focuses on legacy systems transformation towards a service-oriented application. However, SIMM focuses more on the benefits and results of achieving a maturity level versus solely improvement of the process. In addition, SIMM are more on providing a maturity for service integration rather than a SOA maturity itself.

C. CSOAMM

Söderström and Meier (2007) construct a Combined Service Oriented Architecture Maturity Model (CSOAMM) in order to facilitate, interpret and compare the SOAMM with SIMM. Figure 3 show their CSOAMM in the middle irrespective to SIMM on the left and SOAMM on the right.

SIMM	CSOAMM	SOAMM
7. Dynamically reconfigurable services	7. Dynamically reconfigurable services	5. Optimized business services
6. Virtualized services	6. Measured service	4. Measured business services
5. Composite services	5. Internal and external services	3. a. Business services
	4. Architected services	3. b. Collaborative services
4. Simple services	3. Institutionalisation	2. Architected services
	2. First published WS	
3. Componentized	1. Technology tests	1. Initial services
	0. Component	
2. Integrated	-1. Integrated	
1. Silo	-2. Silo	

Figure 3. CSOAMM (Söderström & Meier, 2007).

Their aim was to show that two different SOA maturity models can be combined. They also claimed that their CSOAMM provide a better overview of the SOA maturity and adoption processes. However, their model is not actually a SOA maturity model because they do not provide any evaluation dimension. Their model is just a tool for a communication between SOAMM and SIMM.

D. INAGANTI'S MODEL

Inaganti and Aravamudan (2007) develop a SOA maturity model in order to assess the current state of SOA adoption of an organization. Their ultimate aim is to achieve optimized business services that can quickly adapt to changing business requirements.

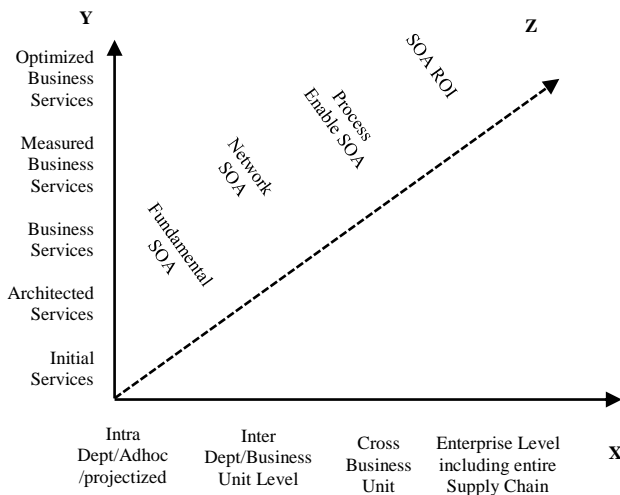

Figure 4. Inaganti's Model (Inaganti & Aravamudan, 2007).

Inaganti's model consists of 3 axes where X axis depicts the scope of SOA adoption, Y axis depicts the SOA maturity level and Z axis depicts the SOA expansion stage. However, Figure 4 shows that Return on Investments (ROI) can only be achieved after the organization has reached both enterprise level of SOA

adoption and level 5 maturity level or optimized business services. Their model also specified that it is significant to define the service types, characteristics and SOA maturity processes. They also stressed that IT key processes were required in order for an enterprise to successfully adopt SOA.

E. iSOAMM

Independent Service Oriented Architecture Maturity Model (iSOAMM) is the SOA maturity model produced by Rathfelder and Groenda (2008). They claimed that their model is a product and technology independent that consider organizational and technical aspects. Furthermore, they also stated that iSOAMM help the selection of the most adequate maturity level by pointing out the benefits, risks and challenges associated to each maturity level. SOA changes from IT perspective supported by an evaluation dimension. Their maturity model is shown in Figure 5.

Maturity Level	Evaluation Dimension				
On Demand SOA	Service Architecture	Infrastructure	Enterprise Structure	Service Development	Governance
Cooperative SOA					
Administered SOA					
Integrative SOA					
Trial SOA					

Figure 5. iSOAMM (Rathfelder & Groenda, 2008).

Based on Figure 5, the maturity levels and evaluation dimensions were constructed to support SOA structure as a whole in details. However, iSOAMM only evaluate the architectural/IT principles of SOA adoption. They omit the business benefits that can be achieved by adopting SOA. Moreover, iSOAMM also was never tested and validated in a real case study. They only evaluate several SOA projects and present the results without the evaluation details.

F. WELKE'S MODEL

Welke et al. (2011) proposed a SOA maturity model based on the capabilities maturity model integration (CMMI). They also constructed the maturity model by using the same basic CMMI terminology but taking into account different motivation for SOA adoption from the perspective of IT administrator, business manager and enterprise leader. Figure 6 shows their proposed SOA maturity model that include five maturity levels: initial, managed, defined, quantitatively managed and optimized.

As shown in Figure 6, Welke's model first view their maturity model as a capability orientation model and secondly they specified that as SOA become more mature, the SOA ability should be fully realized in order to contribute to business operations and organization's service orientation as a whole.

Maternity Level	Evaluation Dimension					
Initial	SOA View	Benefits and Metrics	Business Involvement	Methodology	Service Sourcing	Governance
Managed						
Defined						
Quantitatively Managed						
Optimized						

Figure 6. Welke's Model (Welke et al., 2011).

Furthermore, Welke et al. (2011) also develop a SOA maturity cube that offer a multidimensional view of SOA maturity. The first dimension is for the organization to identify their current levels of SOA maturity according to six defined SOA criteria's and the second is to determine what to do in order to reach the next maturity. However, a fully developed SOA maturity cube is out of scope of their study but the vision is that the organizational can evaluate their SOA-based application on the normal CMMI view or based on how far it progress from the narrowed IT-driven viewpoint toward a broader enterprise transformation viewpoint.

G. SOASMM

The SOA Security Maturity Model (SOASMM) was develop by Kassou and Kjjiri (2012) aims to assess the organizations SOA security maturity. Figure 7 shows the SOASMM was constructed by mapping several methods such as iSOAMM, SSE-CMM and ISO 27002. Figure 7 below presented the SOASMM.

Maternity Level	Evaluation Dimension									
On Demand SOA	Business requirement for access	User access management	User Responsibilities	Network access control	Operating system access control	Application and information	Security requirements of IS	Correct processing in application	Cryptographic controls	Security of file systems
Cooperative SOA										
Administered SOA										
Integrative SOA										
Trial SOA										

Figure 7. SOASMM (Kassou & Kjjiri, 2012).

As shown in Figure 7 above, it connect the SOA maturity level to the security process maturity and the security control applicability. As presented and describe above, it can be clearly seen that SOASMM can be view as a principles of a tool that support the assessment of the SOA security maturity of organization. The aims and interest is to incorporate information security best practice approaches in the paradigm of SOA. However, SOASMM focused more on assessing the SOA security and neglect the evaluation of SOA maturity as a whole.

IV SOA MATURITY MODEL EVALUATION DIMENSION

The existing SOA maturity models focused on a single evaluation dimension. This single evaluation dimension consist of multiple views in order to evaluate the SOA maturity such as architecture, business, scope, method, governance, infrastructure and etc. Table 1 presented the view that several of the existing SOA maturity models have in common. Table 1 also shows the views that existing models have in their single evaluation dimension.

Table 1. Single View of Evaluation Dimension

Evaluation Dimension View	SOA Maturity Model
Business	SOAMM SIMM Inaganti's Model Welke's Model
Architecture	SIMM iSOAMM Welke's Model
Scope	SOAMM Inaganti's Model
Governance	SIMM iSOAMM Welke's Model
Method	SIMM Welke's Model
Infrastructure	SIMM iSOAMM

The evaluation views that were shown in Table 1 were extracted from existing models that have the same view. For example, the business view were included in SOAMM, SIMM, Inaganti's Model and Welke's Model. Apart from the views shown in Table 1, there are other views that existing models included such as service sourcing, service development, information and application but it were only for one particular model and were not included in other models. Thus, it is not shown in this study.

In addition, this study also identified several of existing SOA maturity models that have two similar views in their evaluation dimension. The aim of identifying two similar views is to see whether existing models do provide both views of IT and business perspectives. Table 2 shows two similar views that existing models have in common.

Table 2. Two Similar Views of Evaluation Dimension

Evaluation Dimension View	SOA Maturity Model
Business and architecture	SIMM Welke's Model
Business and scope	SOAMM
Architecture and scope	Inaganti's Model
Business and governance	SIMM Welke's Model
Architecture and governance	SIMM iSOAMM

	Welke's Model
Business and method	SIMM Welke's Model
Architecture and method	SIMM Welke's Model
Business and infrastructure	SIMM
Architecture and infrastructure	SIMM iSOAMM
Governance and method	SIMM Welke's Model
Governance and infrastructure	SIMM iSOAMM
Method and infrastructure	SIMM

Based on Table 2, SIMM and Welke's model included both business and IT perspectives in their evaluation view. However, this study has identified that these views is just a simple view from business and IT perspectives. Furthermore, SIMM and Welke's model also included another view to their model which can make SOA practitioners confused. Section V discussed on the finding and discussion.

V FINDINGS AND DISCUSSIONS

This section is concern with the findings and discussions of this study. Table 3 below compared the existing SOA maturity models based on their maturity levels, evaluation dimensions and general descriptions.

Table 3. SOA Maturity Model Features

	Maturity Level	Evaluation Dimension	Description
SOAMM	1. Initial Service 2. Architected Service 3. Business Service 4. Measured Business Service 5. Optimized Business Service	<ul style="list-style-type: none"> • Prime business benefits • Scope • Critical technology success factors • Critical people & organization success factors • Selected relevant standard 	<ul style="list-style-type: none"> • Focus on achieving the business benefit from the adoption of SOA. • Does not have a clear mapping to CMMI. • Does not provide an evaluation process.
SIMM	1. Silo 2. Integrated 3. Componentized 4. Simple Service 5. Composite Service 6. Virtualized Service 7. Dynamic Reconfigurable Service	<ul style="list-style-type: none"> • Business view • Governance & organization • Method • Application • Architecture • Information • Infrastructure & management 	<ul style="list-style-type: none"> • Focus on providing a service maturity model rather than SOA maturity as a whole. • Does not evaluate the maturity of SOA adoption as a whole. • Does not have a clear mapping to CMMI. • Does not provide an evaluation process.
Inaganti's Model	1. Initial Service 2. Architected Service 3. Business Service 4. Measured Business Service 5. Optimized Business Service	<ul style="list-style-type: none"> • Intra department/ adhoc/ projectized • Intra department/ business unit level • Cross business unit • Enterprise level including entire supply chain 	<ul style="list-style-type: none"> • ROI only become available when organization reached an enterprise level of SOA adoption • Does not have a clear mapping to CMMI. • Does not provide an evaluation process.

CSOAMM	-2.Silo -1.Integrated 0. Component 1. Technology test 2. First Published WS 3. Institutionalisation 4. Architected Service 5. Internal & External Service 6. Measured Service 7. Dynamic Reconfigurable Service	Nil	<ul style="list-style-type: none"> • Aims at providing a communication tool between SOAMM and SIMM. • Clear mapping with CMMI. • Does not have the evaluation dimension elements.
iSOAMM	1. Trial SOA 2. Integrative SOA 3. Administered SOA 4. Cooperative SOA 5. On demand SOA	<ul style="list-style-type: none"> • Service architecture • Infrastructure • Enterprise structure • Service development • Governance 	<ul style="list-style-type: none"> • Independent from technologies and products. • Do not address from business perspective. • Does not have a clear mapping to CMMI. • Does not provide an evaluation process.
Welke's Model	1. Initial 2. Managed 3. Defined 4. Quantitatively-Managed 5. Optimized	<ul style="list-style-type: none"> • SOA View • Benefits and metrics • Business involvement • Methodology • Service Sourcing • Governance 	<ul style="list-style-type: none"> • Focus on providing a capability orientation model. • Clear mapping with CMMI. • Does not provide an evaluation process.
SOASMM	1. Trial SOA 2. Integrative SOA 3. Administered SOA 4. Cooperative SOA 5. On demand SOA	<ul style="list-style-type: none"> • Business requirements for access • User access management • User responsibility • Network access control • Operating system access control • Application & information • Security requirements of IS • Correct processing in application • Cryptographic control • Security of file system 	<ul style="list-style-type: none"> • Focus only on providing a security maturity model for SOA adoption. • Does not have a clear mapping to CMMI. • Does not provide an evaluation process.

From the comparison made in Table 3, the existing SOA maturity models have their own maturity levels and evaluation dimensions. According to Bloomberg (2005), SOA maturity model need to have comparable levels to CMMI's that serve as an alignments of architectural features and capabilities. Based on Table 3, CSOAMM and Welke's Model were the only models that have a clear mapping with CMMI. Nevertheless CSOAMM is not a complete model because CSOAMM does not provide any evaluation dimension. Thus this study chose to enhance Welke's Model because it is a capabilities-orientation model and can be directly mapped to CMMI.

In addition, the existing models do not follow any standard in providing their own evaluation dimension and this circumstance have made their evaluation dimension to contradict with each other. This study proposed to enhance Welke's model evaluation dimension by providing a two dimensional evaluation dimension that focus on IT benefits and business benefits. The idea was to reflect the true definition of SOA where it should be viewed and treated equally from both IT benefits and business benefits (Baghdadi, 2014; Borges & Mota, 2007; Derler & Weinreich, 2007). Furthermore, this study has found that majority of the existing models do not provide an evaluation processes. The existing models only focus on "what" to evaluate rather than "how" to evaluate the maturity of SOA adoption. Therefore, this study has identified that there is a need to improve the SOA maturity model by providing a systematic evaluation components for SOA maturity model.

VI CONCLUSION

In this study, literatures of SOA maturity model were reviewed and compared. SOA maturity model is important to determine the current state of SOA adoption. The results showed that there was a need to provide two-dimensional evaluations in order to reflect the definition of SOA where it should be viewed and treated equally from both IT benefits and business benefits (Baghdadi, 2014; Borges & Mota, 2007; Derler & Weinreich, 2007). Furthermore, this study chose Welke's model as the most suitable model for further enhancement because this model has clear mapping to CMMI. In addition, this study also identified that there is a need to improve the evaluation process in order to provide a complete and systematic evaluation method. Overall, this study provides preliminary analysis; therefore, an extensive work regarding the evaluation dimension and evaluation processes will be presented in the future report.

ACKNOWLEDGEMENT

The authors wish to thank the Ministry of Education, Malaysia for funding this study under the Long Term Research Grant Scheme (LRGS/b-u/2012/UUM/Teknologi Komunikasi dan Infomasi).

REFERENCES

- Ameller, D., Burgess, X., Collell, O., Costal, D., Franch, X., & Papazoglou, M. P. (2015). Development of service-oriented architectures using model-driven development: A mapping study. *Information and Software Technology*, 62(1), 42–66. <http://doi.org/10.1016/j.infsof.2015.02.006>
- Baghdadi, Y. (2014). SOA Maturity Models: Guidance to Realize SOA. *International Journal of Computer and Communication Engineering*, 3(5), 372–378. <http://doi.org/10.7763/IJCE.2014.V3.352>
- Bloomberg, J. (2005). What to Look For in a SOA Maturity Model. Retrieved April 12, 2016, from <http://zaphthink.com/2005/10/31/what-to-look-for-in-a-soa-maturity-model/>
- Borges, R. M., & Mota, A. C. (2007). Integrating UML and Formal Methods. *Electronic Notes in Theoretical Computer Science*, 184(SPEC. ISS.), 97–112. <http://doi.org/10.1016/j.entcs.2007.03.017>
- Cheng, J. C. P., Law, K. H., Bjornsson, H., Jones, A., & Sriram, R. (2010). A service oriented framework for construction supply chain integration. *Automation in Construction*, 19(2), 245–260. <http://doi.org/10.1016/j.autcon.2009.10.003>
- Ciganek, A. P., Haines, M. N., & Haseman, W. D. (2009). Journal of Information Technology Management SERVICE-ORIENTED ARCHITECTURE ADOPTION: KEY FACTORS AND APPROACHES. *Journal of Information Technology*, XX(3).
- Derler, P., & Weinreich, R. (2007). Models and Tools for SOA Governance. *Trends in Enterprise Application Architecture*, 4473/2007, 112–126. http://doi.org/10.1007/978-3-540-75912-6_9
- Feuerlicht, G. (2007). SOA: Trends and Directions, 149–154.
- Ganapathy, K., Priya, B., Priya, B., Prashanth, V., & Vaidehi, V. (2013). SOA Framework for Geriatric Remote Health Care Using Wireless Sensor Network. *Procedia Computer Science*, 19(Fams), 1012–1019. <http://doi.org/10.1016/j.procs.2013.06.141>
- Inaganti, S., & Aravamudan, S. (2007). SOA Maturity Model. *BPTrends*, (April), 1–23. <http://doi.org/10.1007/978-3-319-02453-0>
- Joachim, N., Beimbom, D., Hoberg, P., & Schlosser, F. (2009). Examining the organizational decision to adopt service-oriented architecture (SOA) - development of a research model. *DIGIT 2009 Proceedings*, 4.
- Kassou, M., & Kjiri, L. (2012). SOASMM: A novel service oriented architecture Security Maturity Model. *Proceedings of 2012 International Conference on Multimedia Computing and Systems, ICMCS 2012*, 912–918. <http://doi.org/10.1109/ICMCS.2012.6320279>
- Konigsberger, J., Silcher, S., & Mitschang, B. (2014). SOA-GovMM: A meta model for a comprehensive SOA governance repository. *Proceedings of the 2014 IEEE 15th International Conference on Information Reuse and Integration, IEEE IRI 2014*, 187–194. <http://doi.org/10.1109/IRI.2014.7051889>
- Kontogiannis, K., Lewis, G. A., Smith, D. B., Litoiu, M., Muller, H., Schuster, S., & Stroulia, E. (2007). The Landscape of Service-Oriented Systems: A Research Perspective. *Systems Development in SOA Environments, 2007. SDSOA '07: ICSE Workshops 2007. International Workshop on*, 1. <http://doi.org/10.1109/SDSOA.2007.12>
- Kreger, H., Carrato, T., Arsanjani, A., Szakal, A., Diaz, J., & Holley, K. (2009). IBM Advantage for Service Maturity Model Standards, (August), 1–22.
- Papazoglou, M. (2008). *Web Services: Principles and Technology*. Pearson, Harlow, England. Retrieved from <http://www.worldcat.org/isbn/0321155556>
- Rathfelder, C., & Groenda, H. (2008). ISOAMM: An independent SOA maturity model. *Lecture Notes in Computer Science (Including Subseries Lecture Notes in Artificial Intelligence and Lecture Notes in Bioinformatics)*, 5053 LNCS, 1–15. http://doi.org/10.1007/978-3-540-68642-2_1
- Sedek, K. A., & Omar, M. A. (2013). Interoperable SOA-Based Architecture for E-Government Portal.
- Söderström, E., & Meier, F. (2007). Combined SOA Maturity Model (CSOAMM): Towards a Guide for SOA Adoption. *Enterprise Interoperability II SE - 43*, 389–400. http://doi.org/10.1007/978-1-84628-858-6_43
- Sonic Software, Corporation; AmberPoint, Inc.; BearingPoint, Inc.; Systinet, C. (2005). A new Service-Oriented Architecture (SOA) Maturity Model. Retrieved from http://www.omg.org/soa/Uploaded Docs/SOA/SOA_Maturity.pdf
- Sutawijaya, I. B., & Chiok, S. (2010). *Impact of SOA Adoption with regard to Business Value: A study from South East Asia Bank*. Lund University.
- Welke, R., Hirschheim, R., & Schwarz, A. (2011). Maturity. *Computer*, 44(February), 61–67. <http://doi.org/10.1109/MC.2011.56>

Goal Oriented Measurement for Software Sustainable Evaluation Metric Focused on Environmental Dimension

Ruzita Ahmad, Azham Hussain, and Fauziah Baharom

Universiti Utara Malaysia, Sintok Kedah, rita_azura08@yahoo.com, {azham.h, fauziah}@uum.edu.my

ABSTRACT

Sustainability is a complex concept that investigated in interdisciplinary dimension which are environment, economic, and social. Software sustainability has moved towards new paradigms of research and it is claimed as still immature due to lack of integration on these three dimensions. Currently, there are studies on software sustainability evaluation that defined the evaluation criteria. However, most of the studies are lack of integrating the three dimensions of software sustainability. In addition, the evaluation goals are also not clearly defined. Therefore, the objective of this study is to define the evaluation goals for each proposed characteristic and sub-characteristic with focused to environmental dimension. Goal Question Metric (GQM) is used as a method to identify the correct goals in this study. The adaptation of goal oriented measurement can contribute to define the precisely goals by determining the purposes, perspectives, point of views in the following context of environment with respect to achieve software sustainability.

Keywords: Software sustainability, Goal Oriented Measurement (GOM), evaluation criteria, environmental dimension

I INTRODUCTION

Sustainability is the development that meet the needs of the present generation without compromising the ability of future generation to meet their own needs (Brundtland Commission Report, 1987). Several years ago the concept of sustainability has been practiced in various domain such as manufacturing, construction, restoration of natural disasters, soil and erosion, ecosystems and biodiversity, and so forth. Thus, the transformation view of sustainable development has a strong commitment to the social equity, with a sight that linked to livelihood, health, welfare, resources, economic and political decision are connected each other. Dealing to the context of software engineering, sustainability has been highlighted in software development and known as software sustainability (Koziolek et al., 2011). Software sustainability refers to the software development in which the resources use aims to meet

the needs of present generation until future with integrating the aspects of environment, economic and social towards long living software (Ahmad et al., 2015).

Currently, most of the software products and processes are developed with either an environment, economic or social benefits and not intended to serve with either an environment, economic and social purposes. For instance, the software development nowadays are merely focused on environment and social aspects and did not highlighted the economic aspects as the important element (Penzenstadler et al., 2013; Koziolek et al., 2011). In addition, some of developers focuses on economic and social aspect and ignoring the environment aspect (Penzenstadler et al., 2013; Calero et al., 2013). These development trends are the main reason why the important of sustainability in software engineering. Therefore, the integration of environment, economic and social dimension in software development can support the production towards long living software.

In order to monitor the production of software towards long living software, the needs of measurement mechanism is significantly to guide the software product and process to meet the needs of sustainability requirements. Several software sustainability evaluations has been developed recently. The best known practices models in the literatures such as model proposed by Sarkar et al. (2008), Koziolek et al. (2011), Durdik et al. (2012), Kocak et al. (2012), Venters et al. (2013), Penzenstadler et al. (2013) and Penzenstadler et al. (2014). The models are built with rich of important features towards long living software and claimed to fulfill the sustainability requirements in their assessment mechanism. Unfortunately, most of them are regardless to show the systematic measurement process that only focused on what need to be measured instead of who, when, where, why, and how to measure. Furthermore, the goals for each proposed features in their models does not clearly defined based on the criteria that they aimed to achieve. Therefore, this study intend to improve the limitations of previous works in defining the goals for the proposed features of software sustainability evaluation by using Goal Question Metric (GQM) with focused on environmental dimension.

II LITERATURE REVIEW

This section presents the overview of software sustainability evaluation with discusses the best practices of software sustainability evaluation model in the literature. The outline is continued to the goal oriented measurement for expressing the objective in this study.

A. Software Sustainability Evaluation

Software sustainability evaluation has been expressed by several researchers in different ways. Most of them are based on Tripple Bottom Line (TBL), System Life Cycle (SLC), Life Cycle Assessment (LCA) approach and also several quality models to express their sustainability measurement models. Beneficially, most of them aimed to achieve software sustainability in their own ways based on their theories and practices, activities, opinions and experiences. The best known model of software sustainability metric evaluation in the literatures are proposed by Sarkar et al. (2008), Koziolok et al. (2011), Durdik et al. (2012), Kocak et al. (2012), Venters et al. (2013), Penzenstadler et al. (2013) and Penzenstadler et al. (2014).

Earliest studies by Sarkar et al. (2008) have been proposed the software sustainability metric evaluation based on the scenario-based evaluation. The scenario-based evaluation is single interaction of many scenarios obtained from the nature that can be re-manufactured the software production towards sustainability (Beloff et al. 2004). This concept provides the eliciting, documenting as to evaluate the software development with related to the previous scenarios against the requirements. Although, Sarkar et al. (2008) have been used the Triple Bottom Line (TBL) approach in developing their metric evaluation but they only focusing on environment and economic dimension only without highlighting the social dimension individually.

Further studies by Koziolok et al. (2011) introduces the concept of metric-based evaluation to enhance the limitation studies by Sarkar et al. (2008) in which the researcher has classified the metric evaluation into indicators, indices, and framework through the TBL approach. Even though, the model uses TBL concept with defining the metric evaluation into three sustainability dimension, unfortunately the developer failed to show the integration concept between them. However, the proposed dimensions of evaluation mechanism in this model highlightes the environment and economic dimension, while the social dimension is keep soundless.

Durdik et al. (2012) investigates the software sustainability is necessary to be highlighted using

system life cycle approach towards long living systems. The researcher creates a catalog of sustainability guidelines for the stakeholders such as project managers, software architects, and developers. The evaluation mechanism is an explicit consideration of sustainability during systems design, development, operation, and maintenance. The guidelines consists of selected methods, techniques and tools with reflected to sustainability including method descriptions, information of their industrial validation, supporting tools, potential benefit, connected risks, checklist and references. The researchers expresses the ideas pertaining to the strongly relationship between sustainability and quality model in the literatures. They has defined software sustainability development as the ability for cost efficient maintenance which is influenced by the quality attributes at the architectural level of a software system and the evolution is limited to an economical perspective. The researchers are claimed that the sustainability development related to the whole life-cycle of a software system and much contributed to environmental of the long living systems in the final product. However, the contribution does not performed the evaluation criteria to achieve sustainability.

Kocak et al. (2012) proposes green metrics to quantify the green performance of software systems. The developers defines four clusters of metrics based on the Green Performance Indicators (GPI) namely as IT resource usage metrics, Lifecycle metrics, Energy Impact metrics, and organizational metrics. Eventhough, the proposed characteristic and sub-characteristic by Kocak et al. (2012) are adopted from ISO/IEC 9126 and ISO/IEC 25010, unfortunately they are only addressed for environmental dimension only. For instance, they are assessing the greenness elements of an IT application and to indicate the energy consumption, energy efficiency, and energy saving possibilities. However, the assessment mechanisms are based on what need to be measured instead of who, when, where, why, and how to measure.

In Venters et al. (2013) embeddes the theory adopted from McCall's model in developing metric evaluation based on the merit of the represented entity through the weight given by the stakeholders. The value assigned by the stakeholders are used as the input into their proposed metric evaluation through the standard model recommended by Mc Call through software quality model. This model represents the assessment mechanism by defining the relationship between the proposed characteristic and sub-characteristic. Most of the proposed metrics evaluation are represented in frameworks and the weights are given by the

respected stakeholders. Unfortunately, the definition of goals between the characteristic and sub-characteristics in the proposed model are facing vulnerabilities in measuring the features towards sustainability. In fact, the proposed concept of metric evaluation as same as the previous works, in which the environment and economic dimension are most importantly than social dimension. Consequently, the integration of sustainability dimension does not exist.

The new concept of value viewpoint is highlighted by Penzenstadler et al. (2013) in software development towards software sustainability. The researchers introduces the values, indicators, regulations and activities to be practiced in order to achieve the level of sustainability. An indicator can be qualitative or quantitative metric that will be used to express a specific degree or score with regards as a value. For example: the indicator is risk of investment (ROI) will be used to assess the level of long term profit value and indirectly will be supported the economic sustainability. In the software sustainability, the indicator such as line of code (LOC) will be influenced to the value of (maintainability and efficiency) and indirectly will be supported the technical sustainability which is involved human behavioral (Penzenstadler et al. 2014).

The concept is appropriated through the activities which are measurement technique used to contribute to a specific value or a set of values (Penzenstadler et al., 2013). However, Penzenstadler et al. (2014) added the element of values and regulations into the concept of metric evaluation initiated by Koziolok (2011). The model proposed by Penzenstadler et al. (2013) and Penzenstadler et al. (2014) are the latest sustainability evaluation model that integrated the three pillars dimension of sustainability. Even though the suggested elements are performed in value-based perspective, unfortunately the goals of the values added are did not clearly defined to the other matters such as who, when, why, where and how to measure.

As explained from the previous studies, most of them are proposing the variety of concept association that have been used in the assessment mechanism. The most important element need to be highlighted in the assessment mechanism is the integration of environment, economic and social dimensions towards developing software sustainability. Unfortunately, most of them did not observed the sustainability paradigm as well. However, there only one model is observed the sustainability standard that proposed by Penzenstadler et al. (2013) and Penzenstadler et al. (2014). Despite that, the measurement process for all models in literatures only identify what to be

measured and did not to attend who, when, why, and how to measure.

Consequently, the goals for software sustainability features are not clearly defined in the measurement process to achieve sustainability. Therefore, this study need to improve the limitations of previous works to defined the goals of characteristic and sub-characteristic of software development using the Goal Question Metric (GQM) approach. This approach is encouraging and motivating this research to enhance the software sustainability evaluation metric by utilizing the purposes, perspectives, point of views and the context of environment with fully focused on sustainability dimensions. The details will be discussed in the next sub-section.

B. Goal Oriented Measurement

Goal oriented measurement is a fundamental approach to monitor that all measurement activities be carried out in the context of a well-defined the measurement goal (Morasca, 2002). Basically, the measurement goal should be clearly connected between the proposed features and sub-features in the software development. Furthermore, the concept of software measurement in which the relationship between entity i.e. (software process, software product) and attributes i.e. (external attributes or internal attributes) that need to be measured must be specified entirely consisting of what, who, when, where, why, and how to measure (Pfleger et al., 2001).

In order to identify the specified measurement goal, Goal Question Metric (GQM) is used in this study. GQM paradigm provides a framework for deriving measures that consists of goals, questions, and metric in a hierarchical as a guideline to the users. Goal is defined on a conceptual level as the main point that is compulsory to be attained. Goals can be derived by investigating the policy and the strategy of the organization that uses the GQM. The way to present goals are must be documented in a structured way and using templates for easier referencing.

The measurement goal can be defined by adapting the templates as proposed by Basili et al. (1994). The templates consisting of Purposes i.e. (to characterize, evaluate, predict, motivate and etc) that is pointed out to the object under study i.e. (process, product, model and etc) in order to clarify the object under study i.e. (to understand, assess, manage, engineer, learn, improve, and etc). The second element is Perspective that related to the specific issues or features that is need to be examined i.e. (cost, effectiveness, correctness, defects, changes, product metrics, reliability, and etc), from the point of views of the i.e. (user, developer, manager, customer, corporate

perspective and etc). Next, the third element is Environment focuses on the context of i.e. (process factore, people factors, problem factors, method, tool, constraint and etc). Table 1 illustrates the adapted templates to define goals in the specified measurement. The element of puposes and perspective are remained the same to the original templates, while element of environment is modified to the context of environment, economic, and social dimension of sustainability.

Table 1. Adapted Templates to Define Goals.

Element	Description
Purposes	To (characterize, evaluate, predict, motivate) the (process, product, model, metric) in order to (understand, assess, manage, engineer, learn, improve) it.
Perspective	Examine the (cost, effectiveness, correctness, defects, changes, product metrics, reliability, and etc). From the point of view of the (developer, manager, customer, corporate perspective and etc).
Environment	In the following context of (environment, economic, and social dimension).

III THE GOAL FOR SOFTWARE SUSTAINABILITY EVALUATION

This section presents an example of goals for software sustainability evaluation with focused on environment dimension using the adapted templates illustrated in Table 1 above. The characteristic and sub-characteristic for software sustainability evaluation is proposed in Ahmad et al. (2015) via Systematic Literature Review (SLR). The proposed characteristics and sub-characteristics are defined based on ISO/IEC 9126 (2002) – Product quality namely Efficiency, Functionality, Reliability, Usability, Maintainability, and Portability. In addition, there are new added characteristic in this research namely Integrity and User Conformity. The proposed characteristics and sub-characteristics are organized into the dimension of sustainability such as environment, economic, and social as illustrated in Table 2 below (Ahmad et al., 2015).

Table 2. The Proposed Characteristics and Sub-Characteristics of Software Sustainability Evaluation.

Dim.	Characteristic	Sub-Characteristic
Environment	Efficiency	Time Behaviour, Resource Utilization
	Functionality	Suitability, Accuracy, Interoperability, Security
	Portability	Adaptability, Installability, Co-Existence, Replaceability
	Reliability	Maturity, Fault Tolerance, Recoverability
	User Conformity	User Perception, User Requirement
	Integrity	Data Protection
Economic	Efficiency	Time Behaviour, Resource Utilization
	Maintainability	Analysability, Changeability, Stability, Testability
	Reliability	Maturity, Fault Tolerance, Recoverability
	Usability	Understandability, Learnability, Operability, Attractiveness
	Portability	Adaptability, Installability, Co-Existence, Replaceability
	User Conformity	User Perception, User Requirement
Social	Integrity	Data Protection
	Maintainability	Analysability, Changeability, Stability, Testability
	Functionality	Suitability, Accuracy, Interoperability, Security
	Portability	Adaptability, Installability, Co-Existence, Replaceability
	Usability	Understandability, Learnability, Operability, Attractiveness
	User Conformity	User Perception, User Requirement
	Integrity	Data Protection

Based on Table 2 above, the goal of one characteristic has been defined in Table 3 below as following the templates of goal definition by Basili et al. (1994).

Table 3. Example Defining Goal of Software Sustainability Evaluation for Environment Dimension.

Characteristic	Efficiency
Goal	<p><i>Purposes:</i> To predict the process impact and product impact in order to improve it.</p> <p><i>Perspectives:</i> Examine the performance of energy impact of time behavior and the effectiveness of resource utilization from user, developer, maintainer point of view.</p> <p><i>Environment:</i> In the following context of environmental impact.</p>
Sub-Characteristic	1. Time behaviour
Sub- Goal	<p><i>Purposes:</i> To evaluate the response time behavior in order to improve it.</p> <p><i>Perspectives:</i> Examine the time taken to complete a specified task from the user, developer, maintainer and SQA point of view.</p> <p><i>Environment:</i> In the following context of concurrent tasks and system utilization of the real-time processing, user expectation of business needs or observation of user reaction towards environmental impacts.</p>
Sub-Characteristic	2. Resource Utilization
Sub-Goal	<p><i>Purposes:</i> To evaluate the utilized resources behavior of computer system during testing or operating in order to improve it.</p> <p><i>Perspectives:</i> Examine the input output resource utilization from user, developer, maintainers and SQA point of view.</p> <p><i>Environment:</i> In the following context of quality of use of resources towards environmental impacts.</p>

IV DISCUSSION

As shown in Table 3 above, the definition of goals for Efficiency characteristic are focused on environmental dimension with purposes for software process impact and software product impact. The investigation is centered to the perspectives of energy impact performance of time behavior and the effectiveness of resource utilization. The candidates involved in the measurement are gathered from point of views of user, developer, maintainer, and software quality assurance. The definition of sub-goals are more details in which the purposes, perspectives, and environment's context are fully described as to support the achievement of goal defined. However, the connection of the elements in templates should be related to the theory measurement highlighted by Pfleeger et al. (2001).

Table 4 below illustrates the relationship between the Basili's templates and measurement theory by Pfleeger et al. (2001).

Table 4. Relationship Between Basili's Templates and Pfleeger's Measurement Theory.

Basili et al. (1994)	Pfleeger et al. (2001)
Purposes	What
Perspectives	What, who, where, why, and how
Environment	When, where

The adaptation of Basili's templates in this study can solve the limitation of the previous works that is the measurement process focused on what need to be measured instead of who, when, why, where and how to measure. By using the templates, the definition of goals can be specified into the *Purposes* are responded to what, *Perspectives* are related to what, who, where, why and how, and *Environment* is answered when and where. Finally, the inclusive of goals definition process can monitor the measurement mechanism in developing the metric evaluation towards software sustainability development.

Dealing to the context of software engineering, the environment sustainability dimension is focused on the way of software is created, used, maintained and disposed with minimal impact on environmental (Amri et al., 2014). In addition, the environmental dimension is also referred to the green software in which the properties are influenced by two aspects such as energy consumption and resources consumption. The energy consumption is related to the efficiency of the systems in using the energy efficiency such as runtime efficiency, CPU intensity, memory usage, peripheral intensity, idleness and algorithmic efficiency (Amri et al., 2014). While, the resources consumption aspect related to the software products consists of software and hardware configuration, materials use i.e. print paper, storage media, ink toner and coverage can influence to the level of sustainability in environmental dimension (Penzenstadler et al., 2014).

The Bruntland Commission Report (1987) declares the sustainable development based on environment dimension is the development that preserves the diversity of biological species which is related to the essential ecosystems and ecological processes. The particular environmental sustainability is focused to the human well-being as to improve the human welfare by protecting the natural resources. The element consists of water, land, air, mineral and

ecosystems services. In addition, the elements will be contributed to the consumptions of sources of raw materials used for human needs that centered to the human wastes are under controlled (Gibson, 2006; Ciegis et al., 2009). Therefore, the presented criterias are necessary to be examined for evaluating the level of sustainability achievement in the software development.

V CONCLUSION

The application of GQM is recently used in business driven quality improvement approach very well in many domains. However, this approach currently beneficial to the researcher in developing evaluation metric for software and merely very helpful in defining the goals that need to be achieved towards software sustainability. GQM has much assists in defining the accurate goal and sub-goal for each characteristic and sub-characteristic in this study respectively with fully descriptions on the purposes, perspectives, the point of views, and the context of the environment that are needed to be highlighted. The future work is moved to develop the questions and metrics for each characteristic and sub-characteristic of the proposed list.

ACKNOWLEDGEMENT

The authors wish to thank the Ministry of Education, Malaysia for funding this study under the Long Term Research Grant Scheme (LRGS/b-u/2012/UUM/Teknologi Komunikasi dan Infomasi).

REFERENCES

- Ahmad, R., Baharom, F., & Hussain, A. (2015). A Systematic Review on Characteristic and Sub-Characteristic for Software Development towards Software Sustainability. *World Scientific and Engineering Academy and Society (Wseas) 2015, 23 –25 April 2015, Kuala Lumpur, Malaysia* <http://www.wseas.org/cms.action>
- Ahmad, R., Baharom, F., & Hussain, A. (2014). A Systematic Literature Review on Sustainability Studies in Software Engineering. *Knowledge Management International Conference (KMICe) 2014, 12–15 August 2014, Malaysia* <http://www.kmice.cms.net.my/>
- Basili, V. R., Caldiera, G., & Rombach, H. D. (1994). The goal question metric approach. *Encyclopedia of Software Engineering*, 2, 528–532. doi:10.1.1.104.8626
- Basili, V. R., Heidrich, J., & Lindvall, M. (2007). Bridging the Gap between Business Strategy and Software Development Why Measurement? *International Conference on Information Systems (2007)*, 1–16.
- Basili, V. R., Lindvall, M., Regardie, M., Seaman, C., Heidrich, J., Münch, J., Trendowicz, A. (2010). Linking software development and business strategy through measurement. *IEEE Computer Society*, 43(4), 57–65. doi:10.1109/MC.2010.108
- Beloff, B., Lines, M., & Pojasek, R. . (2004). *Sustainable Development Performance Assessment Beth Beloff* (pp. 1–16).
- Ciegis, R., Ramanauskienė, J., & Martinkus, B. (2009). The Concept of Sustainable Development and its Use for Sustainability Scenarios. *Engineering Economics*, (2), 28–37.
- Calero, C., & Bertoa, M. F. (2013). Sustainability and Quality : icing on the cake. *Journal of Green Engineering*.
- Calero, C., Moraga, M. A., & Bertoa, M. F. (2013). Towards a Software Product Sustainability Model. *Journal of Sustainability*, 25010, 4. Retrieved from <http://arxiv.org/abs/1309.1640>
- Durdik, Z., Klatt, B., Koziolok, H., Krogmann, K., Stammel, J., & Weiss, R. (2012). Sustainability guidelines for long-living software systems. *2012 28th IEEE International Conference on Software Maintenance (ICSM)*, 517–526. doi:10.1109/ICSM.2012.640531
- Gibson, R. B. (2006). Beyond the three pillars : Sustainability Assessment as a Framework for Effective Integration of Social, Economic, and Ecological Considerations in Significant Decision Making. *Journal of Environmental Assessment Policy and Management*, 8(3), 259–280.
- International Organization for Standardization. (2002). Software engineering- Product quality-Part 2: External Metrics (pp. 1–97). Retrieved from http://www.iso.org/iso/sustainable_events_iso_2012.pdf
- Kocak, S. A. (2012). Green Software Development and Design for Environmental Sustainability. *Journal of Green Engineering*.
- Koziolok, H. (2011). Sustainability Evaluation of Software Architectures : A Systematic Review. *Journal of Environmental Assessment Policy and Management*.
- Koziolok, H., Domis, D., Goldschmidt, T., & Vorst, P. (2013). Measuring Architecture Sustainability. *IEEE Software*, 30(6), 54–62. doi:10.1109/MS.2013.101
- Penzenstadler, B., Raturi, A., & Richardson, D. (2014). Safety, Security, Now Sustainability: The Nonfunctional Requirement for the 21st Century. *IEEE Software*, 31, 40–47. doi:10.1109/MS.2014.22
- Penzenstadler, B., & Femmer, H. (2013). A generic model for sustainability with process- and product-specific instances. *Proceedings of the 2013 workshop on Green in/by software engineering - GIBSE '13*, 3.
- Pfleeger, S. L. (2001). *Software Engineering: Theory and Practice*, 2nd ed. Upper Saddle River, N.J: Prentice Hall.
- Sarkar, S., Kak, A. C., & Rama, G. M. (2008). Metrics for measuring the quality of modularization of large-scale object-oriented software. *IEEE Transactions on Software Engineering*, 34(5), 700–720. doi:10.1109/TSE.2008.43
- United Nations World Commission on Environment and Development (1987). Report of the World Commission on Environment and Development: Our Common Future In United Nations Conference on Environment and Development, 1987.
- Venters, C. C., Lau, L., Griffiths, M. K., Holmes, V., Ward, R. R., & Xu, J. (2013). The Blind Men and the Elephant: Towards a Software Sustainability Architectural Evaluation Framework. *Journal of Green Engineering*.

Social Innovation and Strategic Knowledge Management Processes: A Critical Conceptual Overview

Muhamad Nizam Jali, Zakaria Abas, Ahmad Shabudin Ariffin, and Nazim Baluch

*Universiti Utara Malaysia, Malaysia,
mnj_jali@yahoo.com.my, {zakaria; ashabudin@uum.edu.my}, nazimbaluch@gmail.com*

ABSTRACT

This paper conceptually explores social innovation as a new innovation outcome strategy and its association with strategic knowledge management processes. The result of this paper found that social innovation is an outstanding solution in addressing social and economic issues highlighted above, because the outcome of social innovation encompasses social, economic and technological payoffs concurrently. Furthermore, this paper highlights strategic knowledge management processes, creates superior knowledge resource that is regarded as a new and novel solution that can be embedded into products, processes and services which in turn leads to the outcome of improving the quality and quantity of people's life, stimulate economic growth and enhancing technological advances i.e. social innovation. Finally, this paper concludes that social innovation and strategic knowledge management processes must be seriously considered by the policy makers, private sectors and also public institutions given the massive contribution that it might afford to many nations' core aspirations.

Keywords: Social innovation, strategic knowledge management, knowledge resource.

I INTRODUCTION

The outcome of innovation strategy is regarded as the vital ingredient to produce superior products, processes and services which in turn stimulates economic and social growth. In recent economic environment, social innovation is gaining an overwhelming recognition from the policy makers, private sectors and public institutions worldwide due to its massive contribution in solving social, economic and technological problems concurrently (Pue et.al., 2015; Lee & Restrepo, 2015). According to Doherty et.al., (2014) and Altuna et.al.,(2015) technological and other innovation outcomes appear to be ineffective as compared to social innovation in addressing complex social, economic and technological problems. As a result, social innovation has secured an important place within many nations' core policies worldwide. For example, developed countries among others in the UK, USA, highly industrialised European countries and few Asian

countries for example Malaysia have recently included and incorporated social innovation as an outcome strategy in their main agenda of national economic policy initiatives (Shaw & De Bruin, 2013; Westley et.al., 2014; Benneworth & Cunha, 2015; Lee & Restrepo, 2015; Malaysian Economic Planning Unit, 2015).

On the other hand, present economic environment is moving into knowledge based society where new knowledge is regarded as the most strategic intangible resource that can be embedded into products, processes and services in order to make them superior (Chiva et.al., 2014). With that, the association of social innovation as an innovation outcome strategy with strategic knowledge management processes that can produce superior knowledge resource is immensely important considering the outcome of both towards social, economic and technological aspects. Thus, a complete and extensive understanding on the insight of how social innovation and strategic knowledge management processes is linked and connected must be seriously engaged (Battisti, 2012). This is the primary purpose of this paper.

This paper is set out in three sections. First, the paper contributes to the existing social innovation literature by exploring social innovation as an outcome strategy. Secondly, this paper highlights the association of strategic knowledge management processes with social innovation within the context of economic and business environment. This paper will also discuss the Resource Based View (RBV) theory and Knowledge Based View (KBV) theory for understanding as to why superior knowledge resource is an essential resource for social innovation. Thirdly, the paper ends by encasing the conclusion of the thought.

II REVIEW OF SOCIAL INNOVATION LITERATURE

In the literature, the early concept and definition of social innovation is describe as the innovation outcome whose primarily purpose is to achieve social needs and predominately diffused by social organization (Mulgan, 2007). Moreover, Phills et al., (2008) defined social innovation as new solution that creates significant value to solve society problems. However, it is specifically focussed to add value to social aspects of society rather than economic and commercial value. The two descriptions of social innovation mentioned above indicate that the early

concept of social innovation is very much connected with social parlance, where Pol and Ville (2009) term that as 'pure social innovation'. As a result, social innovation does not include private market but merely to satisfy social aspects. From the above statements, social innovation is seen as an old paradigm and centered within the field of public policy and sociology within the literature (Klein, et al., 2010). This situation creates under-investment in today's economic perspectives because of the significant value in the social innovation that might be brought forward to contribute towards improving the quality and quantity of people's life, stimulate economic growth and enhancing technological advances.

From the above paragraph, literature highlighted only recently that social innovation includes and integrates economic and technological approach in order to add value to its existing social purpose approach. This is in order to meet demands in a new economic environment and also because of the massive recognition given by the various policy makers, private sectors and public institutions worldwide (Bitzer & Hamann, 2015). With the integration of economic and technological approach, there is a collective dynamic interplay between social, economic and technological aspects that helps various parties to use social innovation as an outcome within the economic environment that they operate (Altuna et al., 2015).

In addition, Unceta et al., (2016) argued that social innovation is not necessarily tied up to address specific social purposes but its significant value encompasses wide range of innovation outcomes that includes social, economic and technological aspect. Despite the integration of economic and technological aspects within social innovation, literature also highlighted, various recent studies predominantly focusing on the conceptual part of social innovation rather than giving a useful empirical insight on how social innovation as an outcome strategy integrated with social, economic and technological aspects (Lizuka, 2013; Krlev et al., 2014). The review of social innovation literature as an outcome strategy above provides a point of departure in answering how social innovation integrated with social, economic and technological aspects that led to improve quality and quantity of people's life, stimulate economic growth and enhance technological advances. This is the primary goal of this paper. The next section explained the question above by reviewing the association of strategic knowledge management with social innovation.

**III STRATEGIC KNOWLEDGE
MANAGEMENT AND SOCIAL INNOVATION**

According to Nonaka (1991), in an economy where the only certainty is uncertainty, the one sure resource

of lasting new innovation and competitive advantage is knowledge resource. Based on the previous statement, this paper explores the association of strategic knowledge management processes with social innovation. Within the literature, strategic knowledge management can be defined as the ability to identify, create, harness, transfer, integrate and apply superior knowledge resource resident in the individuals, teams or organizations that involves wide range of activities and interactions to improve and creates new innovation i.e. quality products, processes and services which is the key aspect of competitive advantage and to fulfill social needs (Alavi & Leidner, 2001; Meier, 2011; Cajaiba-Santana 2014). Moreover, strategic knowledge management processes create three prominent processes namely; knowledge creation, knowledge transfer and knowledge application (Meier, 2011). To elaborate further, knowledge creation is associated with the development of new knowledge (Nonaka & Takeuchi, 1995; Gourlay, 2006), knowledge transfer refers to the transmission process whereby knowledge is transferred within or across organization boundaries (Argote & Ingram, 2000) and knowledge application is describes as how such knowledge is embedded and applied to create value, new innovation and competitive advantage (Grant & Baden-Fuller, 2004). These three processes of strategic knowledge management provide superior knowledge resource that can be embedded into products, processes and services (Nonaka & Von Krogh, 2009).

In line with the above paragraph, new paradigm of social innovation is defined as a new and novel solution that can be embedded into products, processes and services in order to fulfill social, economic and technological needs and to improved quality and quantity of people's life (Altuna et al., 2015). From the above statement, in ensuring the success of social innovation as an outcome innovation strategy there must be a presence of a new and novel solution (Krlev et al., 2014). Battisti, (2012), Chiva et al., (2014) and Makimattila et al., (2015) describe the new and novel solution which is the main element of social innovation refers to the superior knowledge resource. This superior knowledge resource is embedded into products, processes and services which make them highly innovative and in turn lead to the outcome of improving the quality and quantity of people's life, stimulate economic growth and enhance technological advances (Unceta et al., (2016). Furthermore, the creation of superior knowledge resource is within the processes of strategic knowledge management namely; knowledge creation, knowledge transfer and knowledge

application (Turner & Makhija, 2006; Meier, 2011; Audretsch & Caiazza, 2015). In addition, according to Van Wijk et al., (2008) and Cajaiba-Santana, (2014) university-industry partnership is the strategic platform to implement strategic knowledge management processes in producing superior knowledge resource.

To show evidence, Kanter (2015) states that, social innovation helps to improve societal, economic and commercial related problems by creating new knowledge resource which acts as a novel solution into products, processes and services that work to meet pressing social, economic and technological needs and to improve quantity and quality of people's life. An empirical findings by Surikova et al., (2015) and Kanter (2015) found that in the aspect of poor public education system, social innovation offers new solutions i.e. superior knowledge resource; that contributes to a better future knowledge worker.

Scheuerle et al., (2015) also revealed that the result of deployment of superior knowledge resource within social innovation outcome on the issues of massive unemployment, contributes towards increase in employment among people and also increase in consumption of economic benefits. Moreover, Cajaiba-Santana (2014) and Spiess-Knafl et al., (2015) highlighted that social innovation with the presence of superior knowledge resource leads to the introduction of superior products, processes and services that have a multiplier effects on the economic value in terms of profit maximization, market share monopoly and increase in private performance. El Arifeen et al., (2013) also stressed on the positive effects of social innovation and knowledge resource on the issues of social health. Knowledge resource leads to the establishment of superior medical products that can improve and enhance people's health.

Therefore, social innovation is regarded as an important outcome of innovation providing new and novel solution i.e. knowledge resource; in dealing with social, economic and technological issues and other global issues which are becoming more crucial and requires continuous solutions to cope with (Krlev, et al., 2014).

IV RESOURCE BASED VIEW (RBV) AND KNOWLEDGE BASED VIEW (KBV)

The Resource based view explains how a firm is able to gain a competitive edge using resources available to the firm. According to Barney (1991) a strategic resource meets certain criteria – it is valuable, such that it reduces costs or increases value to customers. It is also rare enough such that competitors do not use the same resource to compete away the value. A strategic resource is also difficult to imitate or

substitute. This quality of inimitability keeps competitors from gaining parity.

Barney (1991) further argues that if resources are mobile and homogenous across the industry, it is not possible to conceive a competitive advantage since any other firm with the same resources can conceive the same strategy and implement it. Building upon the foundation and the criteria of RBV theory, knowledge resource has emerged as the valuable, rare, inimitable and not substitutable resource that can lead to social innovation (Lavie, 2006; Battisti, 2012; Sanzo-Perez et al., 2015). Within the KBV theory, knowledge is regarded as the most significant resource (Nonaka & Takeuchi, 1995; Grant, 1996). KBV theory focuses specifically on the nature and role of knowledge in order to achieve new innovation (James, 2004). The creation of superior knowledge resources that are embedded into products, processes and services provide long term solution and competitive advantage and subsequently contribute towards solving social and economic needs (Bramwell et. al., 2012; Perkmann & Salter, 2012).

Figure 1 illustrates the conceptual view of the association between strategic knowledge management processes with social innovation as an outcomes innovation strategy.

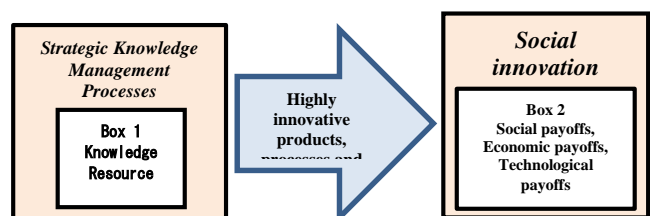

Figure 1. Conceptual View

Figure 1 provides summary of the association between strategic knowledge management processes with social innovation. Box 1 in the strategic knowledge management indicates the output i.e. knowledge resource and box 2 signifies the contribution of knowledge resource on social innovation i.e. social, economic and technological pay offs; by producing highly innovative products, processes and services.

V CONCLUSION

This paper provided an overview of the existing literature on social innovation as an outcome innovation strategy and discussed the association of strategic knowledge management processes with social innovation; the discussion is based on the foundation of RBV and KBV theory in understanding as to why superior knowledge resource is an essential resource for social innovation. Building upon the

above statements, the increasing public awareness on social, economic and technological problems had put social innovation as a new paradigm of innovation strategy in the main agenda by various governments, private sectors and also public institutions worldwide with the aim to improve social well-being and economic growth (Pue et al., 2015). According to Ruede & Lurtz, (2012), economic and social growth of a country is very much dependent on the outcome of social innovation through the integration of strategic knowledge management processes. For example, the application of new novel solutions i.e. knowledge resource; into new products, processes and services in many economic sectors such as in medical, technology, science, education and businesses sectors is said not only to advance the technical aspects but most importantly to improve and enhance quality and quantity of peoples' life (Pol & Ville, 2009; Westley et al., 2014).

However, the literature of social innovation highlighted considerable amount of studies focusing mainly on the theoretical part of social innovation and its association with strategic knowledge management processes. Hence, there is an urgent need for various empirical evidence as to how social innovation and strategic knowledge management processes are connected with each other; subsequently benefitting social, economic and technological aspects. In addition, more empirical studies on social innovation and strategic knowledge management processes will help governments, private sectors and public institutions to learn valuable lessons in dealing with social innovation and strategic knowledge management processes in a more efficient and effective way. Therefore, this paper identifies and provides some promising avenues for future research and offers an improved understanding of the association between social innovation and strategic knowledge management processes within the context of economic and business environment.

ACKNOWLEDGMENT

The authors would like to thank the anonymous reviewers. The authors would also like to give special thanks to the Knowledge Transfer Programme (KTP) secretariat for the funding received under the KTP special research programme titled KTP Problem Statements of Industry/ Community Problems in Malaysia and ASEAN Region, SO code 13319.

REFERENCES

Alavi, M., & Leidner, D. E. (2001). *Review: Knowledge management and knowledge management systems: Conceptual foundations and research issues*. *MIS quarterly*, 107- 136.

- Altuna, N., Contri, A. M., Dell Era, C., Frattini, F., & Maccarrone, P. (2015). *Managing social innovation in for-profit organizations: the case of Intesa Sanpaolo*. *European Journal of Innovation Management*, 18(2), 258-280.
- Audretsch, D., & Caiazza, R. (2015). *Technology transfer and entrepreneurship: cross-national analysis*. *The Journal of Technology Transfer*, 1-13.
- Barney, J.B. (1991). *Firm resources and sustained competitive advantage*. *Journal of Management* 17(1), 99– 20.
- Battisti, S. (2012). *Social innovation: the process development of knowledge-intensive companies*. *International Journal of Services Technology and Management*, 18(3-4), 224-244.
- Benneworth, P., & Cunha, J. (2015). *Universities contributions to social innovation: reflections in theory & practice*. *European journal of innovation management*, 18(4), 508-527.
- Bitzer, V., & Hamann, R. (2015). *The business of social and environmental innovation*. In *The Business of Social and Environmental Innovation* (pp. 3-24). Springer International Publishing.
- Bramwell, A., Hepburn, N., Wolfe, D.A. (2012). *Growing Innovation Ecosystems: University-Industry Knowledge Transfer and Regional Economic Development in Canada*. *Knowledge Synthesis Paper on Leveraging Investments in HERD*. Final Report to the Social Sciences and Humanities Research Council of Canada.
- Cajaiba-Santana, G. (2014). *Social innovation: Moving the field forward. A conceptual framework*. *Technological Forecasting and Social Change*, 82, 42-51.
- Chiva, R., Ghauri, P., & Alegre, J. (2014). *Organizational learning, innovation and internationalization: A complex system model*. *British Journal of Management*, 25(4), 687-705
- Doherty, B., Haugh, H., & Lyon, F. (2014). *Social enterprises as hybrid organizations: A review and research agenda*. *International Journal of Management Reviews*, 16(4), 417-436.
- Economic Planning Unit (2015). *Eleventh Malaysia Plan 2016-2020- Anchoring growth on people*. Percetakan Nasional Malaysia Berhad. Putrajaya: Malaysia.
- El Arifeen, S., Christou, A., Reichenbach, L., Osman, F. A., Azad, K., Islam, K. S., & Peters, D. H. (2013). *Community-based approaches and partnerships: innovations in health-service delivery in Bangladesh*. *The Lancet*, 382(9909), 2012-2026.
- Gourlay, S. (2006). *Conceptualizing knowledge creation: a critique of nonaka's theory*. *Journal of Management Studies*, 43(7), 1415-1436.
- Grant, R.M. (1996). *Toward a knowledge-based Theory of the firm*. *Strategic Management Journal*, vol. 17, no. Special Winter Issue, pp. 109-122.
- Grant, R.M., & Baden-Fuller, C. (2004). *A knowledge accessing theory of strategic alliances*. *Journal of Management Studies*, 41(1), 61-84.
- Kanter, R.M. (2015). *From spare change to real change: The social sector as beta site for business innovation*. *Harvard Business Review*, Vol. 77 No. 3, pp. 122-132.
- Klein, J. L., Tremblay, D. G., & Bussieres, D. R. (2010). *Social economy-based local initiatives and social innovation: a Montreal case study*. *International Journal of Technology Management*, 51(1), 121-138
- Krlev, G., Bund, E., & Mildenerger, G. (2014). *Measuring what matters—Indicators of social innovativeness on the national level*. *Information Systems Management*, 31(3), 200-224.
- Lavie, D. (2006). *The competitive advantage of interconnected firms: An extension of the resource-based view*. *Academy of management review*, 31(3), 638-658.
- Lee, E. W., & Restrepo, J. M. (2015). *Institutional embeddedness and the scaling-up of collaboration and social innovation: The case of a Hong Kong-based international NGO*. *Policy & Politics*, 43(3), 459-471.
- Lizuka, M. (2013). *Innovation systems framework: still useful in the new global context?. UNU-MERIT. Working paper series United Nations*. Maastricht, The Netherlands Innovation, 005.
- Makimattila, M., Junell, T., & Rantala, T. (2015). *Developing collaboration structures for university-industry interaction and innovations*. *European Journal of Innovation Management*, 18(4), 451-470

- Meier, M. (2011). *Knowledge management in strategic alliances: A review of empirical evidence*. International Journal of Management Reviews, 13(1), 1-23.
- Mulgan, G. (2007). *Ready or not: taking innovation in the public sector seriously*. Nest Provocation 03, London: NESTA
- Nonaka, I. (1991). *The knowledge-creating company*. Harvard business review, 69(6), 96-104.
- Nonaka, I. & Takeuchi, H. (1995). *The knowledge creating company: how Japanese companies create the dynamics of innovation*. New York: Oxford University Press, p. 284, ISBN 978-0-19-509269-1.
- Nonaka, I., & Von Krogh, G. (2009). *Perspective-tacit knowledge and knowledge conversion: Controversy and advancement in organizational knowledge creation theory*. Organization Science, 20(3), 635-652
- Perkmann, M., & Salter, A. (2012). *How to create productive partnerships with universities*. MIT Sloan Management Review, 53(4), 79.
- Phills, J. A., Deiglmeier, K., & Miller, D. T. (2008). *Rediscovering social innovation*. Stanford Social Innovation Review, 6(4), 34-43.
- Pol, E., & Ville, S. (2009). *Social innovation: Buzz word or enduring term?* The Journal of Socio-Economics, 38(6), 878-885.
- Pue, K., Vandergeest, C., & Breznitz, D. (2015). *Toward a Theory of Social Innovation*. Innovation Policy Lab White Paper, (2016-01).
- Ruede, D., & Lurtz, K. (2012). *Mapping the various meanings of social innovation: Towards a differentiated understanding of an emerging concept*. EBS Business School Research Paper, (12-03).
- Sanzo-Perez, M. J., Alvarez-Gonzalez, L. I., & Rey-Garcia, M. (2015). *How to encourage social innovations: a resource-based approach*. The Service Industries Journal, 35(7-8), 430-447.
- Scheuerle, T., Schmitz, B., Spiess-Knafl, W., Schues, R., & Richter, S. (2015). *Mapping social entrepreneurship in Germany-a quantitative analysis*. International Journal of Social Entrepreneurship and Innovation, 3(6), 484-511.
- Shaw, E., & De Bruin, A. (2013). *Reconsidering capitalism: the promise of social innovation and social entrepreneurship?*. International Small Business Journal, 31(7), 737-746.
- Spiess-Knafl, W., Mast, C., & Jansen, S. A. (2015). *On the nature of social business model innovation*. Social Business, 5(2), 113-130.
- Surikova, S., Oganisjana, K., & Grinberga-Zalite, G. (2015, May). *The Role of Education in Promoting Social Innovation Processes in the Society*. In *SOCIETY, INTEGRATION, EDUCATION*. Proceedings of the International Scientific Conference (Vol. 4, pp. 233-243).
- Turner, K.L., & Makhija, M.V. (2006). *The role of organizational controls in managing knowledge*. Academy of Management Review, 31(1), 197-217
- Unceta, A., Castro-Spila, J., & Garcia Fronti, J. (2016). *Social innovation indicators*. Innovation: The European Journal of Social Science Research, 1-13.
- Van Wijk, R., Jansen, J.J., & Lyles, M.A. (2008). *Inter-and Intra-Organizational Knowledge Transfer: A Meta-Analytic Review and Assessment of its Antecedents and Consequences*. Journal of Management Studies, 45(4), 830-853.
- Westley, F., Antadze, N., Riddell, D. J., Robinson, K., & Geobey, S. (2014). *Five Configurations for Scaling Up Social Innovation Case Examples of Nonprofit Organizations From Canada*. The Journal of Applied Behavioral Science, 0021886314532945.

Relationship of Knowledge Management Cycle and the Performance from Human, Customer and Organizational Perspective

Rayinda P. Soesanto, Luciana Andrawina, Indriani Rezki Pertiwi, and Amelia Kurniawati

Telkom University, Indonesia, {raysoesanto; luciana; ameliakurniawati} @telkomuniversity.ac.id, indrianirezki@gmail.com

ABSTRACT

Knowledge is a main essential for any companies, because in the knowledge based era, the knowledge itself became the source of competitive advantage. The performance of knowledge management can be measured from the intellectual capital. Intellectual capital is not useful unless it can create some value to the company. Most measurement systems are based on measures of physical and tangible items, this is became problematic when measuring the knowledge management cycle performance in company because the knowledge is intangible assets. This research purpose is to find the relation between the knowledge management cycle and performance. In this research three perspective are used, which are human, customer and organizational perspective. From the data collection, it is known that the KM performance affect the development of all perspective. From the result of this research, the result can be used as knowledge for the company to plan and make better strategic for gaining better competitive advantage.

Keywords: KM Process, Knowledge Management, Human Perspective, Organizational Perspective, Customer Perspective.

I INTRODUCTION

Knowledge is a main essential for any companies, because in the knowledge based era, the knowledge itself became the source of competitive advantage. Today, managing the knowledge in a companies is becoming a core competence that must develop in the companies to ensure succeeding in the competition of the dynamic changing business (Skyrme & Amidon, 1998). Uttami *et al.* (2012) stated that stakeholder in company usually demand the contribution as the knowledge management is implemented in company, the contributions are hopefully can represented a measureable indicators.

The performance of knowledge management can be measured from the intellectual capital. Intellectual capital is not useful unless it can create some value to the company, because of that the company must make sure that the intellectual capital is optimally used to gain values (Kurniawati & Andrawina, 2012). Most measurement systems that measured the knowledge management cycle are based on measures of physical and tangible items, this is became problematic when

measuring the knowledge management cycle performance in company because the knowledge is intangible assets. Performance measurement becomes the basis of strategy establishment for company in the future because it can bring company's vision and strategic target to all member of the company.

This research purpose is to find the relation between the knowledge management cycle and performance based on the knowledge management cycle process developed by Dalkir (2005) and elaborated into new knowledge management cycle model. In this research three perspective are used, which are human, customer and organizational perspective. The stucture of paper are describe as follow, the introduction describe the research background, theoretical background explained the theory that are used in the research, research method describe the methodology, result section describe the data processing, discussion describe the analysis and finding from the research and the last is the conclusion of the research.

II THEORETICAL BACKGROUND

This section discussed the theoretical background that are used in this research.

A. Definition of Knowledge

Knowledge is the skill and also understanding which are used by people to solve problems which includes theory, practice, rule and instruction. Knowledge is built by individual belief about cause and effect relationship (Probst, Raub, & Romhardt, 2000). Knowledge is defined as a fluid mix of experienced, values, information and expert insight that provides some kind of scheme that can evaluated new experience and information (Davenport & Prusak, 1998).

B. Definition of Knowledge Management

Knowledge management is defined as the critical issues from adaptation, will of survive and competence of organization to face the dynamic change of environment (Malhotra, 2005). The main shape of the knowledge management is when organization do a process to find synergic combination from data processing through information technology and creative and innovative capability from the people within organization (Uttami, Kurniawati, & Puspita, 2012).

C. Knowledge Management Cycle

Effective knowledge management requires an organization to identify, generate, acquire, diffuse and capture the benefits of knowledge in organization (Dalkir, 2005). The Knowledge Management Cycle that is used in these research are shown in Figure 1.

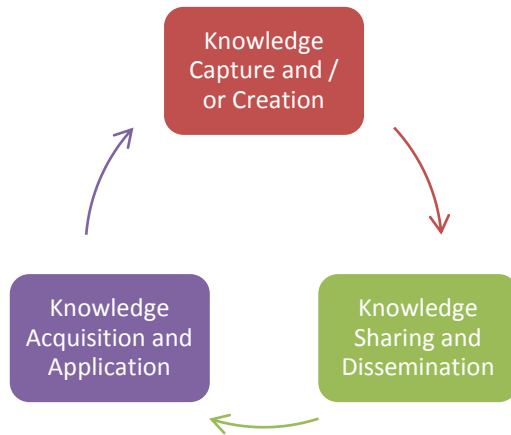

Figure 1. Knowledge Management Cycle.

III RESEARCH METHOD

The knowledge management cycle in this research are elaborated from previous study. Previous study about the KM cycle are conduct by Spender (1996), De Long (1997), Skyrne and Amidon (1998), Dalkir (2005), and Wee and Chua (2013).

Engstrom, Westnes & Westnes (2003) stated that there are three dimension that construct the intellectual capital, which are intellectual agility, performance and attitude and motivation. Human modal represent the individual organizational stock that represent by employee (Bontis & Fitz-enz, 2002). Roos & Roos (1997) stated that employee are created the intellectual modal through competencies, attitude and their intellectual agility.

Table 1. Human Capital Operational Definition.

Dimension	Operational Definition
Intellectual agility	Ability to contextualized a concept and knowledge in order to develop the value creation process
attitude and motivation	Positive attitude and motivation of the members and leaders towards the organization
performance	Work outcome of the organization's members

Customer capital is a relationship between organization with their customer through products. Customer is a business asset, if the organization don't

concern about what customer want, there is a chance that the customer will shift to the competitors product (Payne, 2005). If the organization wants to achieve great financial performance in a long term view, the organization must give a value added product for the customer (Kaplan & Norton, 1996), therefore the customer is the important asset for organization. The customer capital perspective are measured by customer retention, enhanced product/ service quality and better customer handling.

Table 2. Customer Capital Operational Definition.

Dimension	Operational Definition
Customer Retention	Organization attempt to retain the relationship with the customer
Enhanced Product/ Service Quality	Increased product quality and service to customer
Better Customer Handling	Handling complaint when customer interest in product / service

Organizational capital is a capability to renew and improve organization which the output is innovation. The amount of innovation from organization indicate that the people in the organization is active managing the knowledge and thus creating the innovation from one organization. According to Engstrom, Westnes & Westnes (2003), there are two dimension that construct the organizational capital, which are renewal and development and atmosphere. The organizational capital are measured by renewal and development, and atmosphere.

Table 3. Organizational Capital Operational Definition.

Dimension	Operational Definition
Renewal and Development	Ability to create, develop and implement new idea
Atmosphere	Positive atmosphere to create innovation

According to Dalkir (2005), the knowledge management cycle consist of three phase, which are acquisition, sharing and utilization.

Table 4. KM Cycle Operational Definition.

Dimension	Operational Definition
Knowledge Acquisition	Process which is performed to collect, capture and produce knowledge that aligned with the needs an business strategy
Knowledge Sharing	Process which is performed to distribute the knowledge to unit or individual
Knowledge Utilization	Process which is performed to utilize the knowledge by the unit or individual

To find the relation of knowledge management cycle and knowledge management performance, hypothesis are generated based on the literature study. The hypothesis then verified and validate by using questionnaire.

Table 5. Hypothesis of This Research

Hypothesis	Statement	Reference
H1	KM performance give positive impact to development of human capital in organization	Ross & Ross (1997); Bontis & Fitz-enz (2002)
H2	KM performance give positive impact to development of customer capital in organization	Anantatmula & Kanungo (2006)
H3	KM performance give positive impact to development of organizational capital in organization	Engstrom, Westnes & Westnes (2003)

The research object in this research is telecommunication company in Indonesia which has implemented knowledge management in the company. The respondent are selected from the division who involved in knowledge management cycle in the company. Partial Least Square (PLS) method is used in this research to test the hypothesis, the PLS is used because the population of the respondent is limited, the PLS is preferred because it works efficiently with the small sample sizes data, another benefit form PLS is that the statistical power is great, which imply that PLS likely to render a specific relationship significant when it is in fact significant in the population (Hair, Hult, Ringle, & Sarstedt, 2014). Once the questionnaire are being verified and validate, the next step is to analyze the result of the data and hypothesis.

To measure the knowledge management performance, three perspective are used in this research. The human capital perspective are measured using three dimension which are intellectual agility, attitude and motivation, and performance.

IV RESULT

In this research, the respondent are selected from the division who involved in knowledge management cycle in the company, which are Knowledge Management Unit, Human Resource Unit, and ISC Unit. Total respondent are 30 respondent. The questionnaire design are divided into two type of question, which are Yes/No question and perspective view with Likert-Like answer with 4 indicator which consist of "Strongly disagree", "Disagree", "Agree", "Strongly Agree". Table 6 shows the demographic of respondent by working experience, it is known that the most respondent who answer the questionnaire are the respondent who works for more than 16 year in the company.

Table 6. Demographic By Work Experience

Work Experience	Frequency	Percentage (%)
< 1 Year	0	0%
1- 5 Year	1	3%
6 - 10 Year	6	20%
11 - 15 Year	4	13%
More than 16 Year	19	63%

Partial Least Square (PLS) with SmartPLS was used to test and analyze the hypothesized relationships of the research model. PLS model evaluation is done by evaluating the outer and inner model. Outer model is a measurement model to assess validity and reliability of the model. Inner model is a structural model to predict the causal relationships between the latent variables. Table 5 shows the assessment results of the measurement model.

In the first attempt of the calculation process, there are some items that not significant, so the items are removed from the model. The result of measurement model is almost valid based on the rule of thumb: AVE \geq 0.5 and composite reliability \geq 0.7 (Hair, Hult, Ringle, & Sarstedt, 2014). Only the Human Capital dimension that below the rule of thumb, but since its almost close to the rule of thumb, so all the outer model are considered as valid.

Table 5. Measurement Model

Dimension	CR	AVE
Cust_Cap	0.911	0.633
Human_Cap	0.75	0.449
Org_Cap	0.795	0.579
KMC	0.771	0.531

V DISCUSSION

A. Path Diagram

In this research, SmartPLS 3.0 is used to calculate the data, the path diagram for this research is shown in Figure 2.

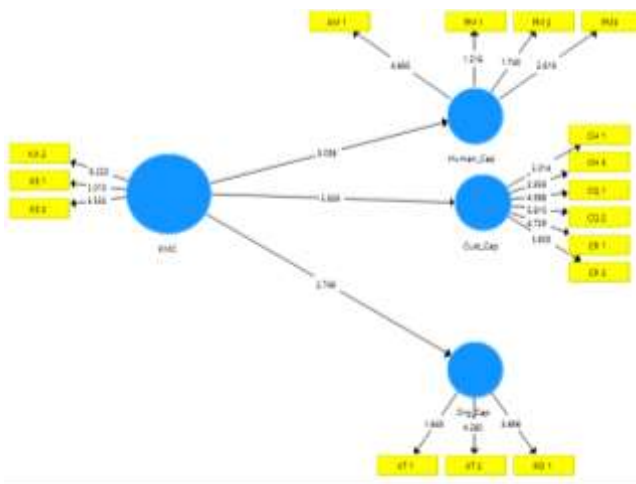

Figure 2. Path Diagram

B. Hypothesis Testing

The hypothesis from literature study can be measured from the t-statistic, with the total respondent of 30, and $\alpha = 0,05$ the t-value is 2.045. based on Hair, Hult, Ringle & Sarstedt (2014), If the t-statistic is greater than the t-value then the hypothesis is accepted. Table 6 shows the t-statistic of each hypothesis.

Table 6. Hypothesis Testing

Hypothesis	Statement	T-Statistic	Decision
H1	KM performance give positive impact to development of human capital in organization	3.058	Accept H1
H2	KM performance give positive impact to development of customer capital	5.939	Accept H2

	in organization		
H3	KM performance give positive impact to development of organizational capital in organization	2.749	Accept H3

From the hypothesis testing, H1 shows that through statistic, the KM performance have positive impact to personnel performance from human capital perspective. The decision based on t-statistic value is accept H2 with value of 3.058, this means that statistically the KM performance influence the personnel/ staff performance in the company. The data is supported by the interview with the staff of KM division that stated that the company have a reward for the KM performance to raise the spirit of all personnel to do the knowledge sharing process. The result from the research are constant with the research from Bontiz and Fitz-enz (2002). The KM Cycle which the organization create is intended to improve the performance of employee by creating the environment which easily share information and to facilitate employee to find specific knowledge.

The H2 Hypothesis shows the relation between the KM performance and the customer capital perspective. The decision based on t-statistic value is accept H2 with value of 5.939, this means that statistically the KM performance will influence the development and loyalty of customer of the company. From the data calculation, it is known that respondent feel that there is a significant connection between customer and the KM performance in the company. The data is supported by the interview with the staff of the company that stated that to maintain the customer loyalty, the company often create Corporate Social Responsibilities (CSR) agenda with creating social event, competition, seminar and incubation process so the customer can get closer to the company and the company can get more info about what customer want. Deming (2000) stated that in order to fulfill the customer needs and for gaining competitive advantage, organization must develop system and process which support sustainable process, high quality service and low cost, the knowledge management role is fit because the process itself already withstand the challenge by transforming management quality process and capture, share and added new knowledge.

The H3 Hypothesis shows the relation between the KM performance and the organizational capital perspective. The decision based on t-statistic value is accept H3 with value of 2.749, this means that statistically the KM performance affect the

development of organizational capital. The result from the data is contradictory with the field result from the company. The use of KM is not in all unit in company, only some department function use KM in their operational activity and from the secondary data, it is known that the innovation process from the company is decreased from 145 to 140. From the interview with the staff of KM, all agree that the culture of organization is considered as “stiff”, it is reflected by the layout of the work area which are partitioned, this result the personnel feel not ease and can’t brainstorming with other personnel to make new innovation, but surprisingly it is said that the “stiff” culture is slowly disappear because the new workforce which are more agile and flexible of changing environment than the old workforce in the company. According to Basu and Sengupta (2007). The success of KM in organization is determined by the organization culture that support the learning, sharing and utilization of knowledge. The climate in organization also affect the success of KM in organization by crating the innovation in organization (Engstrom, Westnes, & Westnes, 2003).

VI CONCLUSION

This research purpose is to find the relation between the knowledge management performance based on the knowledge management cycle process developed by Dalkir (2005) and elaborated into new knowledge management cycle model. In this research three perspective are used, which are human, customer and organizational perspective. From the data collection, it is known that the KM performance affect the development of organizational capital, human and customer capital perspective. From the result of this research, the result can be used as knowledge for the company to plan and make better strategic for gaining better competitive advantage. This research limitation is only in one company, and did not considered other factor such as the use of information system in knowledge sharing process, it is needed to consider the knowledge management system as a tool to sharing performance and the effect to the intellectual capital.

REFERENCES

Anantatmula, V., & Kanungo, S. (2006). Structuring the Underlying Relations Among the Knowledge Management Outcomes. *Journal of Knowledge Management*, 25-42.

- Basu, B., & Sengupta, K. (2007). Assessing success factors of knowledge management initiatives of academic institutions—a case of an Indian business school. *The Electronic Journal of Knowledge Management*, 273-282.
- Bontis, N., & Fitz-enz, J. (2002). Intellectual Capital ROI : A causal map of human capital antecedents and consequents.
- Dalkir, K. (2005). *Knowledge Management in Theory and Practice*. London: The MIT Press.
- Davenport, T., & Prusak, L. (1998). *Working Knowledge*. Cambridge: Harvard Business School Press.
- De Long, D. (1997). Building the Knowledge-Based Organization : How Culture Drives Knowledge Behaviors. *Center for Business Innovation*, 1-29.
- Deming, E. (2000). *Out of the crisis*. Massachusetts: MIT Press.
- Engstrom, T., Westnes, P., & Westnes, S. (2003). Evaluating Intellectual Capital in the Hotel Industry. *Journal of Intellectual Capital*, 287-303.
- Hair, J. F., Hult, G. M., Ringle, C. M., & Sarstedt, M. (2014). *A Primer On Partial Least Squares Structural Equation Modelling (PLS-SEM)*. London: Sage Publication.
- Kaplan, R., & Norton, D. (1996). *Balanced Scorecard : Menerapkan Strategi Menjadi Aksi*. Jakarta: Erlangga.
- Kurniawati, A., & Andrawina, L. (2012). Indicators for Knowledge Management Performance Measurement From Human Capital Perspective using Knowledge Management Balanced Scorecard. *International Seminar on Industrial Engineering and Management* (pp. 187-192). Manado: ISIEM.
- Malhotra, Y. (2005). Integrating Knowledge Management Technologies In Organizational Business Processes: Getting Real Time Enterprises To Deliver Real Business Performance. *Journal of Knowledge Management*.
- Payne, A. (2005). *Handbook of CRM : Achieving Excellence in Customer Management*. Oxford: Butterworth-Heinemann.
- Probst, G., Raub, S., & Romhardt, K. (2000). *Managing Knowledge Building Blocks for Success*. Chichester: John Wiley & Sons.
- Ringle, C., Wende, S., & Becker, J.-M. (2015). SmartPLS. Boenningstedt, Germany.
- Roos, G., & Roos, J. (1997). Measuring your company's intellectual performance. *Long range planning*, 413-426.
- Skyrme, D., & Amidon, D. (1998). NEW MEASURES OF SUCCESS. *Journal of Business Strategy*, 20-24.
- Spender, J. (1996). Making Knowledge The Basis of Dynamic Theory of The Firm. *Strategic Management Journal*, 45-62.
- Uttami, N. W., Kurniawati, A., & Puspita, I. A. (2012). Evaluasi Kinerja Knowledge Management Berdasarkan Perspektif Human Capital dengan Metode Knowledge Management Balanced Scorecard di PT Bank X. *Technology, Industry, and Entrepreneurship Conference (TIEC)*, (pp. 5-10). Padang.
- Wee, J., & Chua, A. (2013). The peculiarities of knowledge management processes in SMEs: the case of Singapore. *Journal of Knowledge Management*, 658-972.

Importance Factors Influencing the Thai Doctors in Rural Area to Use Public Social Media for Work-Related Use: A Case Study of LINE Application

Nattapong Somsakit, Suree Funilkul, and Umaporn Supasitthimethee

King Mongkut's University of Technology Thonburi, Thailand, {55130700614; suree; umaporn} @sit.kmutt.ac.th

ABSTRACT

The inefficient distribution of doctors in rural areas is the issued need to be achieved. Many doctors in rural hospitals which are new graduated and lack of experience are unable to diagnose and treat all types of illnesses, and need collaboration with urban-based medical specialties. Meanwhile, public social media has become a major role of daily life, it can enable real-time interaction, collaboration, implicit knowledge sharing with facilitate from Social Capital. This study purposes to examine the importance factors influencing the Thai doctors in rural area intention to use public social media for work-related use by using social capital theory assessment integrated with UTAUT model. This research model is empirically using survey data from 148 participants of the doctors in rural areas. All of six research hypotheses were positively significant supported. The results indicated that; Performance Expectancy is the most associated factor with using LINE application for social-related use and then social-related use can enable work-related use through Social capital. Meanwhile, the study suggests that the doctors can use LINE application as work-related use for real-time interaction, collaboration and knowledge sharing with others.

Keywords: Tacit knowledge sharing, Social Capital, Work-Related Use, UTAUT Model, LINE Application, Public Social Media.

I INTRODUCTION

The critical shortage of doctors in many countries is the worldwide issue that needs to be achieved (World Health Organization, 2006). In Thailand, the inefficient distribution of doctors in rural areas has a major impact on access to healthcare for those living in rural communities especially specialists are tend to cluster in metropolitan areas (Pagaiya, Kongkam, & Sriratana, 2015; Wacharasint, 2014). Then rural hospitals which are primary care center provide lower quality healthcare services because of the lack of experienced doctors who generally unable to diagnose and treat all types of illnesses (Simmons, 2010). With low doctors densities and lack of experienced doctors lead to the difficulty of access to intensive care services for critically ill patients living in the

rural areas (Wacharasint, 2014). So this means rural hospitals have to transfer some critically ill patients to other hospitals with appropriate facilities and experienced specialists for diagnosis and treatment which are costly and time-consuming (Al-Safadi, 2016). To overcome this problem, many researches aim to enable doctors in the rural areas to collaborate urban-based medical specialties such as presenting a real-time traffic information-based emergency medical service (RTIEMS) system by providing ECG signals, temperature, oxygen, and pulse wirelessly transmitted to server located in the hospital emergency room (Tan et al., 2012), Prasad et al. (2010) provided a tool for doctors to view medical images online and collaborate over the Internet and introduced a telemedicine platform that supports a real-time, ubiquitous, collaborative, and interactive meeting environment equipped with 3D visualization facilities (Maani et al., 2009). The collaboration between doctors in rural areas and specialties is in form of sharing practical, experience knowledge and decision making (Kothari et al., 2012) which is implicit knowledge sharing because critically ill patients need diagnosis and treatment accurately and quickly. With the advent of public social media, it can facilitate implicit and experiential knowledge sharing among experts sharing, particularly where experts are not always geographically co-located, through free-form, real-time, interactive and collaborative technologies, such as social networking and online discussion forums (Abidi et al., 2009).

This study purposes to examine the importance factors influencing the Thai doctors in rural area intention to use public social media for work-related use by using social capital theory assessment integrated with UTAUT model. The result will reveal the entire factors that influenced the Thai doctor intention to use LINE application through social capital which affect to work-related purposes. The survey research methodology is described and the results presented, followed by discussion, conclusion and further work.

II LITERATURE REVIEW

Nowadays, public social media has become a major role with our daily life which has capabilities to enable user for co-creation the content, provide effective real-time communication in forms of chatting, video conferencing, and encourage building a knowledge

community though discussion about interest issues gather together in online space (Panahi, Watson & Partridge, 2012). From Thailand internet user survey in 2015 indicated that the most popular public social media are Facebook (92.1%) and Line (85.1%) which have common features to enable people chatting/message, share image, audio and video etc. Although Facebook is the most popular public social media but LINE application has the highest growth rate by 23% (Electronic Transactions Development Agency, 2016; Thailand Zocial Award, 2015). From the capabilities of public social media, people are able to meet and communicate with friends to obtain a sense of belongingness and to develop relationships, individuals accumulate their social capital as a consequence of daily social interactions, but it is also feasible to make intentional investments in social interaction (Cao et al., 2012).

Currently, the rapid growth of public social media make our daily life more convenient and occur new opportunities for many businesses. In the organization aspect, several organizations tried to explore how to use public social media to improve work effectiveness but they may be hesitant regarding using public social media within organization may interfere with employee's work (Sun & Shang, 2014). But several studies revealed that public social media can improve work effectiveness, Leftheriotis & Giannakos (2014) found that public social media can improve employees' work effectiveness more than losing time, employees use public social media to find new customers, recruit personnel, keep contact with customer and watch market or competitors. Consistent to Leonardi, Huysman, & Steinfield (2013) proposed that many organizations have employed intraorganizational social media to enable employees to share files and digital resources and connect with or follow partners.

In the medical field, there are studies about using social media within physician, Bosslet, Torke, Hickman, Terry, & Helft (2011) studied about the use of online social media for patient interaction among medical students (MS), resident physicians (RS) and practicing physicians (PP), the result shows that all three kind of physicians use online social media for patient interaction which practicing physicians use it at the most.

Social capital, a set of resources embedded within an individual or organization relationships, is valuable for both individual and organization participants. In this study, we focus on all three dimensions of social capital as structural, relational and cognitive dimension. Social capital has been a critical factor for successfully use public social media because it enables facilitating interactions, cooperation, knowledge acquisition, and sharing among people (Sun & Shang,

2014; Lin, 2011; Putnam, 1995). The continuance use of public social media can strengthen their social capital building due to the potential for interaction and communication among people (Jin, 2013).

Several previous studies revealed that social capital has results in benefits for organization, (Peng, Fang, & Lim, 2011) reveals that social capital encourages user acceptance of numerous IS used in organizations, Zhongju Zhang (2010) indicated that group members with a clear, shared vision exhibit greater team orientation, which exerts a direct influence on users' system use. Furthermore, Hau, Kim, Lee, & Kim, (2013) revealed that social capital acts as a motivational factor in knowledge sharing intention, self-related expertise, and tenure. The result is related to Cao et al. (2012) found that social media can enhance trust among employees and leading to transfer implicit knowledge which is more effective than explicit knowledge.

Hanson et al. (2011) studied about adoption of social media among health educators based on UTAUT model and found that supporting from organization or supervisor (social influence) and perform better at work (Performance Expectancy) are the key factors which are influenced their acceptance. Social capital is purposed as one of the key factor for successfully use social media for work-related use in this study.

From related literature showed that the consistent of benefit between social media and social capital can improve work effectiveness by facilitating cooperation, knowledge transfer and knowledge absorption. Then they can enable implicit knowledge sharing among experts which related to this study.

III RESEARCH MODEL

To study the importance factors influencing the Thai doctors in rural area to use public social media for work-related use: LINE application, the research proposes six hypotheses based on the factors in UTAUT model and social capital theory (Sun & Shang, 2014; Lin, 2011; Putnam, 1995). In this study, we had eliminated some variables: age, gender, experience and voluntariness as shown in Figure 1.

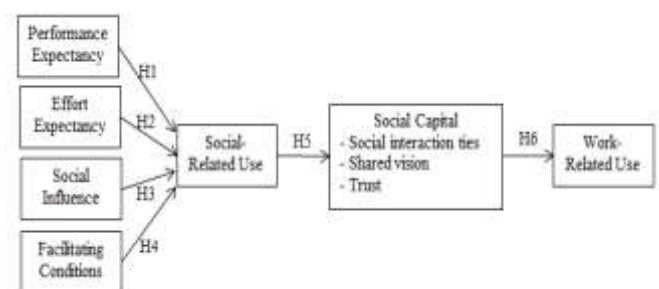

Figure 1. Research Model.

A. Performance Expectancy [PE]

Performance Expectancy is defined as the degree to which an individual believes that using the system will help him or her to attain gains in job performance (Venkatesh et al, 2003). In this study, Performance Expectancy is meant that doctors believe that using LINE application has benefits for their social activities such as increasing the chances to communication with others and access to information easier. We propose the following hypothesis:

H1: Performance Expectancy (PE) is positively related to the Thai doctors in rural area using LINE application for social-related use (SRU).

B. Effort Expectancy [EE]

Effort Expectancy is defined as the degree of ease associated with the use of the system (Venkatesh et al, 2003). In this study, Effort Expectancy is meant that doctors feel that LINE application is easy to use such as user friendly interface, easy to learn to use. We propose the following hypothesis:

H2: Effort Expectancy (EE) is positively related to the Thai doctors in rural area using LINE application for social-related use (SRU).

C. Social Influence [SI]

Social Influence is defined as the degree to which an Individual perceives that important others believe he or she should use the new system (Venkatesh et al, 2003). In this study, Social Influence is meant that the opinions from colleagues and supervisors effects using LINE application for social activities of doctors. We propose the following hypothesis:

H3: Social Influence (SI) is positively related to the Thai doctors in rural area using LINE application for social-related use (SRU).

D. Facilitating Conditions [FC]

Facilitating Conditions are defined as the degree to which an individual believes that an organizational and technical infrastructure exists to support use of the system (Venkatesh et al, 2003). In this study, Facilitating Conditions is meant that doctors will use LINE application for social activities when they have adequate resources such as mobile phone and internet, supporters when they face the issues while using. We propose the following hypothesis:

H4: Facilitating Conditions (FC) is positively related to the Thai doctors in rural area using LINE application for social-related use (SRU).

E. Social Capital [SCP]

In this study, we focus on all three dimensions of social capital as structural, relational and cognitive dimension (Sun & Shang, 2014; Lin, 2011; Putnam,

1995). Using LINE application for social activities among doctors will create or maintain relationship among them and the development of social interaction. When doctors interact with each other over time, it will develop a concrete knowledge of each other and likely to develop trust in other doctors. And doctors also perceive shared vision through social interaction such as sharing information, resources and organizational vision. We propose the following hypothesis:

H5: Thai doctors in rural area to using LINE application for social-related use (SRU) positively affect to social capital (SCP).

F. Work-Related Use [WRU]

When doctors have highly shared vision can avoid the misunderstanding opportunities to exchange ideas or resources freely and also when trust is exists, the opportunities to sharing information and collaboration will be increased for work-related use (Sun & Shang, 2014). We propose the following hypothesis

H6: Social capital (SCP) of the Thai doctors in rural area using LINE application positively affects to work-related use (WRU).

IV RESEARCH METHODOLOGY

A. Questionnaire

We use questionnaire to estimate research model by reviewing theory and related research which are Venkatesh et al (2003) about UTAUT model and Sun & Shang (2014). The questionnaire consists of two sections. Firstly, the demographic of respondents were asked. Secondly, respondents were asked about the attitude about acceptance and intention to use LINE for work-related use. The questionnaire is constructed with the 5-point likert scale (1-Strongly disagree 2-Disagree 3-Neutral 4-Agree 5-Strongly agree) as shown in table 1. Because this research was conducted in Thailand and the population were Thai doctors, so the questionnaire from the original version proposed by Venkatesh et al (2003) and Sun & Shang (2014) was translated into Thai language to clearly understand.

To test the reliability, we conducted a preliminary analysis using pilot test from 30 samples. We used Cronbach's alpha coefficient as a measure which should be greater than 0.7 for acceptable internal consistency. As a result, the Cronbach's alpha is 0.840 which indicates a high level of internal and all constructs are acceptable which is greater than 0.7.

To analyze the relationship between factors influencing the Thai doctors in rural area to use public social media for work-related use, we conducted a

linear regression using Statistical Package for the Social Science: SPSS Version 22.

B. Participants

The sample size for this study is calculated based on the principle of Yamane (Yamane, 1973). A total of 420 questionnaires are distributed to the sample group which is Thai doctors in northeast of Thailand including Sakon Nakhon, Udonthani, Nong Khai, Loei, Nong Bua Lamph, Maha Sarakham and Khon Kaen Province. But total of 148 valid responses were collected as a valid response rate of 35% as shown in Table 1.

Table 1. Description of sample.

Attribute	Value	N	Percent
Gender	male	71	47.97
	female	77	52.03
Age(years)	20-25	29	19.59
	26-30	51	34.46
	31-40	30	20.27
	41-50	24	16.22
	>51	14	9.46
LINE usage experience(months)	1-6	5	3.38
	7-12	8	5.41
	13-24	60	40.54
	>25	75	50.68
Work experience(years)	1-5	79	53.38
	6-10	19	12.84
	11-15	15	10.14
	>16	35	23.65

From Table 1, male and female are similar in number, 71 (47.97%) and 77 (52.03%) respectively. The result shows that most participants are 26-30 years old which are 51 (34.46%) followed by 31-40 years old and 20-25 at 30 (20.27%) and 29 (19.59%) respectively. And result also shows that almost participants have experience using LINE application which use more than 25 months mostly. But most participants have less working experience (1-5 years) at 79 (53.38%).

V RESULTS

For the result of this study, Multiple Regression Analysis was conducted to test the hypotheses of research model. A significance level is 0.05 ($p < 0.05$). The relationship between Performance Expectancy (PE), Effort Expectancy (EE), Social Influence (SI) and Facilitating Conditions (FC) to Social-Related Use (SRU) is described in Table 2.

TABLE 2. Result of hypothees H1, H2, H3 and H4

Variables	R ²	SE _{est}	β	t	Sig. ¹¹
PE			0.430	8.323	0.000*
EE			0.134	2.570	0.011*
SI			0.298	5.675	0.000*
FC			0.259	5.144	0.000*
Total	0.748	0.283			0.000*

The result in Table 2 is described that the combination of Performance Expectancy (PE), Effort Expectancy (EE), Social Influence (SI) and Facilitating Conditions (FC) has relationship with Social-Related Use (SRU) at the significance level with $p = 0.000$ ($p < 0.05$), a predictive relationship was 74.8% and standard error of prediction is ± 0.283 . Then

H1: Performance Expectancy (PE) is positively related to the Thai doctors in rural area using LINE for Social-related use (SRU) at the significance level with $p = 0.000$ ($p < 0.05$) and $t = 8.323$. Then β value is 0.430 which means that if Performance Expectancy (PE) is increased, the Social-related use (SRU) can be increased too.

H2: Effort Expectancy (EE) is positively related to the Thai doctors in rural area using LINE for social-related use at the significance level with $p = 0.011$ ($p < 0.05$) and $t = 2.570$. Then β value is 0.134 which means that if Effort Expectancy (EE) is increased, the Social-related use (SRU) can be increased too.

H3: Social Influence (SI) is positively related to the Thai doctors in rural area using LINE for social-related use (SRU) at the significance level with $p = 0.000$ ($p < 0.05$) and $t = 5.675$. Then β value is 0.298 which means that if Social Influence (SI) is increased, the Social-related use (SRU) can be increased too.

H4: Facilitating Conditions (FC) is positively related to the Thai doctors in rural area using LINE for Social-related use (SRU) at the significance level with $p = 0.000$ ($p < 0.05$) and $t = 5.144$. Then β value is 0.259 which means that if Facilitating Conditions (FC) is increased, the Social-related use (SRU) can be increased too.

The relation between for Social-related use (SRU) and social capital (SCP) is described in Table 3.

TABLE 3. Result of hypotheses H5

Variables	R ²	SE _{est}	β	t	Sig. ¹
SRU	0.551	0.360	0.742	13.391	0.000*

¹¹ Significant Levels: *: $p < 0.05$

H5: Thai doctors in rural area to using LINE for Social-related use (SRU) positively affect to Social capital (SCP) at the significance level with $p = 0.000$ ($p < 0.05$) and $t = 13.391$, a predictive relationship was 55.1 % and standard error of prediction is ± 0.360 . Then β value is 0.742 which means that if Social-related use (SRU) is increased, the Social capital (SCP) can be increased too.

Then Table 4 is shown the relationship between Social capital (SCP) and Work-related use (WRU).

TABLE 4. Result of hypotheses H6

Variables	R ²	SE _{est}	β	t	Sig. ¹²
SCP	0.405	0.516	0.636	9.959	0.000*

H6: Social capital (SCP) of the Thai doctors in rural area using LINE positively affects to Work-related use (WRU) at the significance level with $p = 0.000$ ($p < 0.05$) and $t = 9.959$, a predictive relationship was 51.6 % and standard error of prediction is ± 0.516 . Then β value is 0.636 which means that if Social capital (SCP) is increased, the Work-related use (WRU) can be increased too.

The result from six hypotheses can be concluded that all hypotheses are supported at the significance level ($p < 0.05$) which can be described in Table 5.

TABLE 5. Summary result of all hypotheese

Hypotheses	R ²	Sig. ²	Conclusion
PE → SRU	0.748	0.000*	Support
EE → SRU		0.011*	Support
SI → SRU		0.000*	Support
FC → SRU		0.000*	Support
SRU → SCP	0.551	0.000*	Support
SCP → WRU	0.405	0.000*	Support

VI DISCUSSION

This research is the study of importance factors influencing the Thai doctors in rural area to use LINE application for work-related use. The research model purposes to examine contribution factors for social-related use, social capital to promote work-related use.

The result shows Performance Expectancy (PE), Effort Expectancy (EE), Social Influence (SI) and Facilitating Conditions (FC) are important factors influencing the social-related use of LINE application. It seems that when doctors found LINE application is useful for their social activities, makes their life easier, perceives the opinions of colleagues and supervisors and supported by facilities such are equipment and

internet access. It is likely that they will have more chances to use LINE application for their social activities.

Social-related use is positively impacted to social capital by helping interaction among doctors develop a concrete knowledge of each other and improvement trust among them. And doctors also perceive shared vision through social interaction such as sharing information, resources and organizational vision.

When doctors interact with each other over time, it will develop a concrete knowledge of each other and likely to develop trust in other doctors. And doctors also perceive shared vision through social interaction such as sharing information, resources and organizational vision. Doctors which are highly shared vision and trust will enable work-related use by avoiding the misunderstanding opportunities to exchange ideas or resources freely and increasing opportunities to sharing information and collaboration.

When doctors have highly shared vision can avoid the misunderstanding opportunities to exchange ideas or resources freely and also when trust is exists, the opportunities to sharing information and collaboration will be increased for work-related use including posting updates and sharing about work and organization policies with colleagues, arranging meetings and gaining access to others with expertise in a particular area.

VII CONCLUSION

This research is the study of importance factors influencing the Thai doctors in rural area to use LINE application for work-related use. The research model is designed based on UTAUT model and social capital with six hypotheses proposed. All hypotheses are positively significantly supported; the result shows that Performance Expectancy, Effort Expectancy, Social Influence and Facilitating Conditions can promote social-related use. Then using LINE application for social-related use can promote work-related use through its effect on increasing social capital which consists of social interaction ties, shared vision and trust among doctors.

Due to the limitation of this research is the focus on public social media only. Thus in the further study, it would be interesting to adapt this research to study the acceptance of new medical technologies.

REFERENCES

- Abidi, S. S. R., Hussini, S., Sriraj, W., Thienthong, S., & Finley, G. A. (2009). Knowledge sharing for pediatric pain management via a Web 2.0 framework. In MIE (pp. 287-291).
- Al-Safadi, L. (2016). The Effects of Real-Time Interactive Multimedia Teleradiology System. BioMed Research International, 2016.
- Bosslet, G. T., Torke, A. M., Hickman, S. E., Terry, C. L., & Helft, P. R. (2011). The patient-doctor relationship and online social networks: Results of a national survey. Journal of general internal medicine, 26(10), 1168-1174.

¹² Significant Levels: *: $p < 0.05$

- Cao, X., Vogel, D. R., Guo, X., Liu, H., & Gu, J. (2012, January). Understanding the influence of social media in the workplace: an integration of media synchronicity and social capital theories. In System Science (HICSS), 2012 45th Hawaii International Conference on (pp. 3938-3947). IEEE.
- Electronic Transactions Development Agency (Public Organization), Ministry of Information and Communication. (2016). Thailand Internet User Profile 2015, pp. 31-52.
- Hanson, C., West, J., Neiger, B., Thackeray, R., Barnes, M., & McIntyre, E. (2011). Use and acceptance of social media among health educators. *American Journal of Health Education*, 42(4), 197-204.
- Hau, Y. S., Kim, B., Lee, H., & Kim, Y. G. (2013). The effects of individual motivations and social capital on employees' tacit and explicit knowledge sharing intentions. *International Journal of Information Management*, 33(2), 356-366.
- Jin, C. (2013). The perspective of a revised TRAM on social capital building: The case of Facebook usage. *Information & Management*, 50(4), 162-168.
- Kothari, A., Rudman, D., Dobbins, M., Rouse, M., Sibbald, S., & Edwards, N. (2012). The use of tacit and explicit knowledge in public health: a qualitative study. *Implement Sci*, 7(1), 20.
- Leftheriotis, I., & Giannakos, M. N. (2014). Using social media for work: Losing your time or improving your work?. *Computers in Human Behavior*, 31, 134-142.
- Leonardi, P. M., Huysman, M., & Steinfield, C. (2013). Enterprise social media: Definition, history, and prospects for the study of social technologies in organizations. *Journal of Computer-Mediated Communication*, 19(1), 1-19.
- Lin, C. P. (2011). Assessing the mediating role of online social capital between social support and instant messaging usage. *Electronic Commerce Research and Applications*, 10(1), 105-114.
- Maani, R., Camorlinga, S., & Eskicioglu, R. (2009, February). A remote real-time PACS-based platform for medical imaging telemedicine. In SPIE Medical Imaging (pp. 72640Q-72640Q). International Society for Optics and Photonics.
- Pagaiya, N., Kongkam, L., & Sriratana, S. (2015). Rural retention of doctors graduating from the rural medical education project to increase rural doctors in Thailand: a cohort study. *Human resources for health*, 13(1), 10.
- Panahi, S., Watson, J., & Partridge, H. (2012). Social media and tacit knowledge sharing: Developing a conceptual model. *World academy of science, engineering and technology*, (64), 1095-1102.
- Peng, Z., Fang, Y., & Lim, K. (2011). Social capital and user acceptance of enterprise system: Mediating role of local management commitment.
- Prasad, D. D., Ray, S., Majumdar, A. K., Mukherjee, J., Majumdar, B., Paul, S., & Verma, A. (2010). Real time medical image consultation system through Internet. *Journal of Healthcare Engineering*, 1(1), 141-154.
- Putnam, R. D. (1995). Bowling alone: America's declining social capital. *Journal of democracy*, 6(1), 65-78.
- Simmons, J. (2010). Primary care needs new innovations to meet growing demand. *HealthLeaders*. May, 27, 23.
- Sun, Y., & Shang, R. A. (2014). The interplay between users' intraorganizational social media use and social capital. *Computers in Human Behavior*, 37, 334-341.
- Tan, T. H., Gochoo, M., Bilgee, S., Chang, C. S., Hu, J. J., Chen, Y. F., ... & Hsu, J. C. (2012, December). Development of an emergency medical service system based on wireless networks and real-time traffic information. In Computerized Healthcare (ICCH), 2012 International Conference on (pp. 35-42). IEEE.
- Thailand Zocial Award 2015. (2015). Retrieved 5 March 2016, from <http://www.zocialinc.com/zocialawards2015/slides/thailandzocialawardsslide3.pdf>
- Venkatesh, V., Morris, M. G., Davis, G. B., & Davis, F. D. (2003). User acceptance of information technology: Toward a unified view. *MIS quarterly*, 425-478.
- Wacharasint, P. (2014). The Role of Health Information Technology on Critical Care Services in Thailand. *J Med Assoc Thai*, 97(1), 127-131.
- World Health Organization. (2006). The world health report: 2006: working together for health.
- Yamane, Taro. "Statistics: an introductory analysis-3." (1973)
- Zhang, Z. (2010). Feeling the sense of community in social networking usage. *IEEE Transactions on Engineering Management*, 57(2), 225-239.

Critical Analysis in Proposing Persuasive Multimedia Model of Truancy Awareness (PMTA)

Mohamad Lutfi Dolhalit¹, Sobihatun Nur Abdul Salam², Ariffin Abdul Mutalib², and Muhamad Saiful Bahri Yusoff³

¹Universiti Teknikal Malaysia, Malaysia, lutfi@utem.edu.my

²Universiti Utara Malaysia, Malaysia, {sobihatun; am.ariffin}@uum.edu.my

³Universiti Sains Malaysia (Kelantan), Malaysia, msaiful_bahri@usm.my

ABSTRACT

This article reports on the ongoing research to propose a persuasive multimedia model of truancy awareness (PMTA) for secondary school students. Accordingly, 9 related models were compared and systematically analyzed with the main objectives to: i). Review and analyses the previous applications and models that are related to the development PMTA Model. ii). Identify and select the generic component in designing the PMTA model. Accordingly, by investigating the selected model, this study suggest the common components applied by the researchers in developing a persuasive application to create awareness. The result of the reviews, shows there are four general components and seven sub-component were outlined. In addition, future work need to be conducted to extract and gathering the detail of sub-component that contains in each common component.

Keywords: Persuasive Technology, Multimedia, Truancy Awareness.

I INTRODUCTION

Literature review on a number of awareness studies by using persuasive technology have been reported on pro-environmental awareness (e.g., Centiero, Romao and Dias, 2011), passengers safety in aircraft evacuations (e.g., Chittaro, 2012), fire safety (e.g., Chittaro and Zangrando, 2010), environmental health (e.g., Filonik, Medland, Foth, Rittenbruch, 2013; Foster et al., 2010), healthy lifestyle among patients with chronic disease (e.g., Gasca, Favela and Tentori, 2008), sustainable lifestyle (e.g., Kuznetsov and Paulos, 2010; Thieme et al., 2012), public awareness and discourse (e.g., Valkanova, Jorda, Tomitsch and Vande, 2013), and stretching for heavy computer users (e.g., Chen, 2014). In most of the awareness studies, persuasive principles, methods, techniques and models have been used to build a certain awareness level of persuasive technology.

As reported by Byrnes (2015) from Massachusetts Institute of Technology (MIT) Technology Review 2015, persuasive technology had been embedded by software developers by using this technologies to measure customer behaviour and to design a products

that are not just persuasive but specifically aimed at building new habits. Fogg (1999) explained, a technology designed purposely to change attitudes or behaviour of the users through persuasive messages and social influence is called persuasive technology or captology derived from "computer as persuasive technology" as illustrated in Figure 1.

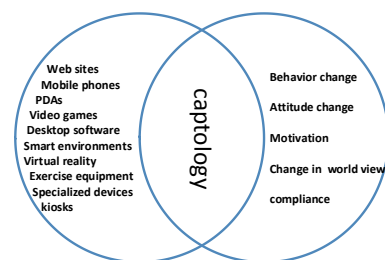

Figure 1. Captology

Multimedia influence as persuasive technology have been discussed by Holbert and Tchernevv (2013) and Mayer (2009). Multimedia technology in education has offered a new way of learning in which the learners can have access to the material and learn from various platforms in obtaining the knowledge (Mayer & Moreno, 2002). The applications of multimedia technology played an important role in assisting the delivery of persuasive messages Spagnolli, Chittaro and Gamberini (2016) thus can assist in behavior change.

In the context of truancy awareness, as reported by Ministry of Education Malaysia from year 2008-2012 in 2012 school session, there are a total of 107,191 students were involved in discipline problems. Report shows that, the highest number of students' misbehaviour was truancy (17343) followed by impolite behaviour (15407), criminal behaviour (14321) and smoking (14298). This figure demonstrated that there is a need to propose a strategy in handling with truancy behaviour in secondary schools.

As suggested by Chong, Lee, Roslan and Baba (2015), research shows self-awareness is identified as one of the important areas that can improve student attendance and student performance besides school policies, supervision and program. However study by

Kuo and Kuo (2015), surprisingly found that very little indication exists that school systems are using multimedia instruction as a solution for truancy prevention. Thus the lack of studies on the effects of using multimedia technology on truancy awareness prompts questions about its importance. This finding are also supported from preliminary studies by Mohamad Lutfi, Sobihatun and Ariffin (2016) where it is found that there is no such multimedia application in truancy awareness or any educational materials to support the learning process.

In conjunction with the statement, the main purpose of this study is to propose a persuasive multimedia model of truancy awareness (PMTA) among secondary school students, with two specific objectives as follows:

- 1) To review and analyses the previous applications and models that are related to the development PMTA Model.
- 2) To identify and select the generic component in designing the PMTA model.

This paper is presented in the following order; introduction, methodology, followed by the systematic review, comparative analysis, findings and discussion and ends with the conclusion and future work.

II METHODOLOGY

In order to achieve the stated objectives, three phases of activities were employs which are (i) literature review, (ii) systematic review and (iii) comparative analysis. The relationship between the activity and output of this study is summarized in Table 1.

Table.1. Summary Of Activity

Activities	Output
1. Literature Review	Selection and justification of 9 previous persuasive technology applications and models.
2. Systematic review	Understand the common component of PT model.
3. Comparative analysis	Selection of generic elements of PMTA model.

As illustrated in Table 1, the first phase started with literature review, which involved 9 selected models related to persuasive technology and awareness studies from reputable journal. The selected models were reviewed and analyzed to validate the suitability of the model with this study. Second phase involved a systematic review in which the common elements were selected. Lastly comparative analysis conducted

to extract the generic component for the development of PMTA model. The finding of the related activities is discussed in the following section.

III SYSTEMATIC REVIEW ON EXISTING MODEL

Prior to proposing the components of PMTA model, a systematic review and analysis of the selected model and application were conducted. They are discussed critically as follow:

A. The Persuasive Power of Virtual Reality.

The use of virtual reality (VR) as a simulation tool provides users with experience of their actions and effects in a vivid and memorable ways. This study by Chittaro (2010) concern on how to create awareness of personal fire safety, which focus on attitudes towards smoke in evacuating buildings. The model utilizes social cognitive theory by Bandura (2004) which emphasized learning through observation/simulation. The virtual simulation experience was created that allows the user to realistically experience an evacuation of a burning building and try for herself the effects of staying in smoke or avoiding it. In terms of functional roles of computer, this study adopts computer as a persuasive tool and as a media simulation by using the principle of cause & effects, virtual rehearsal and suggestion in the application development.

B. A transformational product to improve self-control strength.

Although the field of Persuasive Technologies only emphasises in a way on how to change attitudes and behaviour, sometimes it often neglects the science of self-awareness to change the attitude or behaviour. Research by Kehr, Hassenzahl, Laschke and Diefenbach (2012) is an example of how to foster self-awareness through an interactive machine called "Chocolate Machine". Chocolate machine consists of a slim container filled with wrapped chocolate balls and every 30 minutes the machine will test users' resistance by releasing a chocolate ball onto the desktop. The user can choose either to eat the chocolate or return it back to the machine. This machine is an example on how persuasive technology can be as a tool in which principle of conditioning and self-monitoring is embedded while providing a continuous positive experience.

C. Inair: Indoor Air Quality Measurements And Visualizations

The awareness of the indoor air quality is important due to the contribution to chronic diseases. Kim, and Paulos (2010) suggested inAir, a real-time measurements and visualizations device of indoor air quality and sharing the information within a social network. As a tool inAir device provides users

measured indoor air quality and the explanation on how to improve the pollutant. Sharing mechanism to trigger positive activities by social influence plays important role in understanding the relative level of air quality across people. Thus principle of self-monitoring, surveillance and conditioning were applied in this study. inAir device also act as computer as persuasive media where, as a media it is simulating the cause and effects the consequences of pollutant to human wellbeing.

D. UpStream: Motivating Water Conservation with Persuasive Displays.

The most precious natural resources for human being is a water. However the increased demand for water has led to worsening quality of water. Thus, a study by Kuznetsov and Paulos (2010) aims to raise awareness and motivate water conservation through the integration of persuasive displays and a water-flow sensors in a public and private homes. Persuasive display named “UpStream” were used a tool to display water usage by individual and the collective water usage is displayed in a persuasive interface. This persuasive display functions as a self-monitoring system which suggest the amount of low, average and above average water use. In the context of computers roles the “UpStream” functions as a persuasive tools and media simulation.

E. Mobile Persuasive Application to Encourage Reduction of Users’ Exposure to Cell Phone RF Emissions

The risk of exposure to the radio frequency (RF) emission is possibly harmful to human except hands-free devices such as earphones were used. Therefore, to foster awareness in reducing the emissions, Burigat and Chittaro (2014) proposed BrainSaver, an Android application to monitors user’s call behaviour and gives feedback about how the user is behaving with respect to the use of earphones. Health-related messages such as notifications and visualizations based on persuasive principles were used in a way to provide users with feedback about their behaviour. Principle of tailoring, suggestion and conditioning is the main principle in a persuasive technology tools used in the Brainsaver, such as reminder, feedback, reinforcement and engagement. Cause-and-effects, virtual rehearsal and virtual rewards act as persuasive technology media in the application.

F. The Perception of Sound and its Influence in the Classroom.

The effects of class noise substantially gives disadvantages to the students’ learning. Noise is related to the disturbance to both students and teachers. To control the student’s noise Reis and Correia (2011) proposed a game named “The Castle of Count Pat” an experimental study which capture

sound and represent the noise in graphical data in a real time. An avatar character name “Pat” and “Moon” act as a persuasive social actors which attract student to keep quiet, reward will be given if the student managed to achieve a certain level of noise. This game act as persuasive tool and social actor as a persuasive strategy where this functional role influence the students’ attention towards teacher.

G. Persuading Users They Need Up-to-Date Antivirus Protection

Security option by antivirus software to persuade users to update the antivirus pattern appears to have limited effect of the user’s behaviour. Thus, there is a need to outline a strategy to apply instructional intervention education to solve this issue. Zhang-Kennedy, Chiasson and Biddle (2014) proposed infographic and an online interactive comic (webcomic) to increase users’ awareness and motivate them with the correct use of antivirus protection. Persuasive technology as media is the main component of this study, especially when mental model infographics on how the antivirus works in reality were used. Principle tailoring suggestion and conditioning were applied in both of the prototype.

H. ECOISLAND: Persuading users to reduce CO2 emissions.

In response to the global climate issues and awareness on the CO2 emissions reductions, Takayama (2009) proposed a game application named EcoIsland, a with the aim to persuade and assisting individual families in changing their lifestyle patterns to reduce CO2 emissions. House surrounding installed with a display which present as a virtual island. Gamers can customise their own avatar as social actors which reflect the similarity to the gamer’s character. Principle of tailoring were used such as selecting the target setting of CO2 by 20% and the gamers should follow the rules to achieve the target. Along with the game play, the game will suggest the type of activity that should be achieved to maintain the CO2 level. Gamers will collaborate to monitor members’ activities and will be penalized if fail, resulting in game over.

I. Designing for reflection and social persuasion to promote sustainable life-styles.

This paper by Thieme et al., (2012) aims to contribute to an understanding of how technology can promote ecological awareness and environmentally sustainable lifestyles in individuals. To develop the awareness, BinCam a social persuasive system to motivate reflection and behavioural change in the food waste and recycling habits of young adults were created. BinCam employed transtheoretical model (TTM) as a strategy to support the individual in achieving

behaviour change. Whereas the theory of planned behaviour (TPB) serves as a conceptual framework in which to predict and explain behaviour. Other than that, to support engagement and reflection with BinCam social influence using Facebook was used to share their efforts in recycling. This will trigger reflections on their own using pictures of activities and collaboration with others recycling and food waste behaviours.

IV FINDING OF SYSTEMATIC REVIEW

Based on the analysis and review, there are a number of reasons why the model was selected for the purpose of this study. In general, most of the studies are basically focused on persuasive design guideline or process to ensure the developed persuasive application will match with the targets users especially in awareness study. Other than that, some of the model discuss persuasive strategy that includes principle, technique and approach to increase their awareness toward certain context or issues. Some of the studies suggested the importance of learning theory, approach and instructional strategy to support behaviour change.

Some of the studies also stress on the methods, technologies and medium used to deliver the persuasive contents, this include comprehensible presentation, some with the logical presentation structure, and some with the good persuasive contents to support the intended outcome. In can be concluded that, the process of development of PMTA must include four general aspects its persuasive system design as listed below.

- i. **The intent** focus on the intended outcome of the persuasive system towards user's attitude or behaviour or both.
- ii. **The strategy** is important in analysing the direct or indirect message to be delivered. Strategy guidelines more emphasizes on two strategic elements namely, macrosuasion strategy and microsuation strategy to deliver the message and to route of the messages
- iii. **The event** focus on implementation of the persuasive system from the problem domain to encourage users to set goals and assist them to discover new ways for achieving specific targets in a systematic way.
- iv. The **prototyping process** focus on the development process of persuasive system application for evaluation and demonstration.

Other components that include in the design guideline is i. Persuasive Principle ii. Persuasive Technique iii: Technology or medium, v. Instructional technology vi. Prototyping process.

In short, it has to be emphasized that, this analysis was carried out to discover the essential components

in PMTA model based on the general aspects as above. Hence next section will discuss a comparative analysis of to form the general structure of PMTA model.

V COMPARATIVE ANALYSIS

Accordingly, in formulating the general component of the PMTA model a comparative analysis was conducted to get generic component for the development of PMTA model. The analysis was conducted through the model, function and snapshots of the developed prototype and the elaboration of discussion and finding of the selected study. Then the common components of the model are extracted.

Table 1 plot the common component of each of the selected conceptual design models and categorized it in terms of their common components.

Table 2. Common Component Of Model

Common Component	A	B	C	D	E	F	G	H	I	T
Intent										
Problem Specification	x		x		x	x		x	x	6
Problem statement		x		x	x			x		4
Strategy										
Macrosuasion Strategy	x	x		x	x			x	x	6
Microsuasion Strategy	x			x	x	x	x	x	x	7
Event										
Learning Theories						x	x			2
Learning Approach		x	x							2
Instructional Strategy						x	x			2
Instructional Design		x				x		x	x	4
Prototyping	x		x	x		x	x	x	x	7

X: indicates the persuasive component used in the model/application

T: Total

A-I: Model and application

VI FINDING OF COMPARATIVE ANALYSIS

Based on the comparative analysis, there are four main components that are compulsory to be included in the PMTA model. Problem specification and statement will be combined since its share the same features and meaning in model development. As most of the listed model shares the similar format, so it is essential to have the structural component to formulate the general structure of PMTA model. With the aim of this study to propose a conceptual model to assist developers/designers a successful design step in developing truancy awareness applications, therefore

the common component gathered from the existing model is illustrated in Figure 2. This general structure of PMTA model does not specify the specific step, rather than an iterative process to complete the development process.

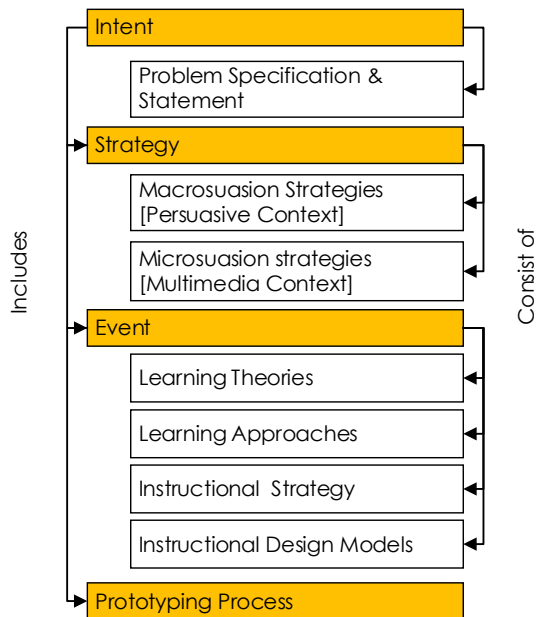

Figure 2. General Component Of PMTA Model.

VII CONCLUSION AND FUTURE WORK

Overall, most of the reviewed article showed that, persuasive technology can be an effective tool for changing attitudes and learning purposes concerning in creating awareness topics. Having understood the general process of persuasive system development for PMTA will leads to the construction of the complete structure of the PMTA model. Derive from comparative study four main components were proposed, intent, strategy, event and prototyping. Accordingly, each sub-component were also extracted this include problem specification and statement, macrosuasion and microsuasion technology. Besides that instructional technology were also important to create learning application.

In summary, the proposed PMTA model gives particular attention on how to create awareness using multimedia contents with the help of persuasive strategies. Thus, understanding the common components applied by the researchers in developing a persuasive application to create awareness towards certain behavior really implicated this study. Accordingly, by understanding the related components it will help to develop PMTA model in a systematic way.

The next step of this study will involve with more comparative analysis to extract and gathering the

detail of sub-component that contains in the common component. In addition, consultation with expert will be conducted to review and validate the model. Afterward, the complete validated model will be tested through a prototyping. The finding of the future research will be presented in the next articles.

ACKNOWLEDGMENTS

The authors are momentarily obliged to UUM, UTeM, and Malaysian Ministry of Education (MOE) for providing financial assistance through FRGS grant for the research reported in this paper and providing support and facilities that have facilitated the research process along this year.

REFERENCES

- Bandura, A. (2004). Social cognitive theory for personal and social change by enabling media. *Entertainment-education and social change: History, research, and practice*, 75-96.
- Byrnes, N. (2015). Technology and Persuasion. Retrieved Mei 06, 2015, from <http://www.technologyreview.com/news/535826/technology-and-persuasion/>
- Burigat, S., & Chittaro, L. (2014). Designing a mobile persuasive application to encourage reduction of users' exposure to cell phone RF emissions. In *Persuasive Technology* (pp. 13-24). Springer International Publishing.
- Centieiro, P., Romão, T., & Dias, A. E. (2011, November). A location-based multiplayer mobile game to encourage pro-environmental behaviours. In *Proceedings of the 8th International Conference on Advances in Computer Entertainment Technology* (p. 31). ACM.
- Chen, Y. X., Chiang, S. S., Chih, S. Y., Liao, W. C., Lin, S. Y., Yang, S. H., ... & Hung, Y. P. (2014). Opportunities for Persuasive Technology to Motivate Heavy Computer Users for Stretching Exercise. In *Persuasive Technology* (pp. 25-30). Springer International Publishing.
- Chittaro, L. (2012). Passengers' safety in aircraft evacuations: Employing serious games to educate and persuade. In *Persuasive technology. Design for health and safety* (pp. 215-226). Springer Berlin Heidelberg.
- Chittaro, L., & Zangrando, N. (2010). The persuasive power of virtual reality: effects of simulated human distress on attitudes towards fire safety. In *Persuasive Technology* (pp. 58-69). Springer Berlin Heidelberg.
- Chong, A. M., Lee, P. G., Roslan, S., & Baba, M. (2015). Emotional Intelligence and At-Risk Students. *SAGE Open*, 5(1), 2158244014564768.
- Filonik, D., Medland, R., Foth, M., & Rittenbruch, M. (2013). A customisable dashboard display for environmental performance visualisations. In *Persuasive Technology* (pp. 51-62). Springer Berlin Heidelberg.
- Fogg, B. J. (1999). Persuasive Technologies. *Communications Of the ACM*, 42(5), 26-29.
- Gasca, E., Favella, J., & Tentori, M. (2008). Persuasive virtual communities to promote a healthy lifestyle among patients with chronic diseases. In *Groupware: Design, Implementation, and Use* (pp. 74-82). Springer Berlin Heidelberg.
- Holbert, R. L., & Tchernev, J. M. (2013). Media influence as persuasion. *The Sage handbook of persuasion*, 36-52.
- Joshi, D., & Dutta, I. Emotional Intelligence among Secondary Students: Role of Gender and Type of Schools. *MIER Journal of Educational Studies, Trends & Practices*, 4(2), (2014), 167-182.
- Kehr, F., Hassenzahl, M., Laschke, M., & Diefenbach, S. (2012, May). A transformational product to improve self-control strength: the chocolate machine. In *Proceedings of the SIGCHI Conference on Human Factors in Computing Systems* (pp. 689-694). ACM
- Kim, S., & Paulos, E. (2010, April). InAir: sharing indoor air quality measurements and visualizations. In *Proceedings of the SIGCHI*

- Conference on Human Factors in Computing Systems (pp. 1861-1870). ACM.
- Kuznetsov, S., & Paulos, E. (2010, April). UpStream: motivating water conservation with low-cost water flow sensing and persuasive displays. In Proceedings of the SIGCHI Conference on Human Factors in Computing Systems (pp. 1851-1860). ACM.
- Kuo, Y. C., & Kuo, Y. T. (2015, March). Online Learning and Dropout Prevention in K-12 education. In Society for Information Technology & Teacher Education International Conference (Vol. 2015, No. 1, pp. 364-373).
- Mayer, R. E., & Moreno, R. (2002). Aids to computer-based multimedia learning. *Learning and Instruction*, 12(1), 107-119. [http://doi.org/10.1016/S0959-4752\(01\)00018-4](http://doi.org/10.1016/S0959-4752(01)00018-4).
- Mohamad Lutfi, D., Sobihatun Nur, A.S., & Ariffin, A. M. (2016). A Preliminary Study: The Availability of Multimedia Applications in Truancy Awareness. *International Journal Of Interactive Digital Media*, Vol. 4(1), ISSN 2289-4098, e-ISSN 2289-4101
- Reis, S., & Correia, N. (2011). The Perception of Sound and its Influence in the Classroom. In *Human-Computer Interaction-INTERACT 2011* (pp. 609-626). Springer Berlin Heidelberg.
- Spagnolli, A., Chittaro, L., & Gamberini, L. (2016). Interactive Persuasive Systems: A Perspective on Theory and Evaluation. *International Journal of Human-Computer Interaction*, 32(3), 177-189.
- Takayama, C., Lehdonvirta, V., Shiraiishi, M., Washio, Y., Kimura, H., & Nakajima, T. (2009, March). Ecoisland: A system for persuading users to reduce CO2 emissions. In *Future Dependable Distributed Systems, 2009 Software Technologies for* (pp. 59-63). IEEE.
- Thieme, A., Comber, R., Miebach, J., Weeden, J., Kraemer, N., Lawson, S., & Olivier, P. (2012, May). We've bin watching you: designing for reflection and social persuasion to promote sustainable lifestyles. In Proceedings of the SIGCHI Conference on Human Factors in Computing Systems (pp. 2337-2346). ACM.
- Valkanova, N., Jorda, S., Tomitsch, M., & Vande Moere, A. (2013, April). Reveal-it!: the impact of a social visualization projection on public awareness and discourse. In Proceedings of the SIGCHI Conference on Human Factors in Computing Systems (pp. 3461-3470). ACM.
- Zhang-Kennedy, L., Chiasson, S., & Biddle, R. (2014). Stop clicking on "update later": Persuading users they need up-to-date antivirus protection. In *Persuasive Technology* (pp. 302-322). Springer International Publishing.

A Requirement Model of an Adaptive Emergency Evacuation Center Management

Nor Laily Hashim, Hanif, Azham Hussain, Noraziah ChePa, and Yuhanis Yusof

Universiti Utara Malaysia, Malaysia, {laily, azham.h, aziah, yuhanis}@uum.edu.my; hanif.balfas@yahoo.com

ABSTRACT

Among all natural disasters, flood is not only becoming increasingly dangerous, but is also recording the highest percentage of occurrences. Previous studies on flood disaster have provided solutions to deal with the problem. However, these research do not anticipate the scenario whereby evacuation centers are drowned by heavy flood. Besides, there were also no provision for requirement models which can be used as reference guides. This study proposes a requirement model for a decision aid model for evacuation center management which is capable of providing smart solutions for the relocation of victims to other evacuation centers should the flood level become increasingly dangerous. The methodology used in this study consists of five phases: requirement gathering, conceptual design, development, verification, and preparing thesis & articles for publication. This study has produced a requirement model of the proposed system that consists of a use case diagram, use case specifications, class diagrams, and sequence diagrams, which have been reviewed by experts using inspection method. The proposed requirement model can be used as a reference model for developers in producing similar evacuation center management system.

Keywords: requirement model, smart evacuation center management, flood, relocation.

I INTRODUCTION

Natural disasters have become worldwide issues. 94 countries have been affected by 317 natural disasters in 2014, causing 8,186 deaths worldwide (the International Federation of Red Cross and Red Crescent Societies (IFRC), 2015). Between 1995 and 2015, 6,768 natural disasters occurred (Davies, 2016; Reduction, 2015). These disasters include flood, storm, earthquake, extreme temperature, landslide, drought, wildfire, and volcanic activity.

In the recent 2015 flood tragedy, several evacuation centers (EC) in Kuala Krai were submerged, despite the information that the rescuing teams and EC staff acquired from the e-banjir portal. This portal provides information related to current water level, number of victims at each EC, and quantity of flood supply and other relevant, significant information. However, the

decision to reallocate the victims to other safer ECs by the rescuing teams was delayed. Consequently, the victims were only moved to other centers when flood water reached the third floor of one school building that served as an EC (Bernama, 2015). This therefore, has triggered the needs of having a decision support aid that is able to provide solutions to assist EC staff to make quick and accurate decision to reallocate the trapped victims to the safest EC. Rusdi Ishak, an officer of the Kedah Department of Social Welfare, has also expressed the same view (Ishak, 2014).

The numerous research on flood in Malaysia are directed on planning for flood disaster (Ghazali, 2006), designing flood management system (Norliza Katuk, Ku Ruhana Ku-Mahamud, Norita Norwawi, 2009), applying knowledge management concept in managing flood information (Maidin, Othman, & Ahmad, 2014; Yahya, 2014), and flood simulation using Geographical Information Management (Kia et al., 2012). Foreign researchers, on the other hand, concentrate on reallocating victims from their residences to ECs (response phase) and are more focused on flood prevention (preparedness phase). Multi-period optimization model (Gama, Scaparra, & Santos, 2013), maximal covering location problem (MCLP) with Lagrange optimization model (Santos et al., 2013), and Shelter Location-Allocation Model (Kongsomsaksakul, Yang, & Chen, 2005) are some studies on reallocating the resources from people's residences to evacuation centers. They focus on formulation and algorithm. Neither prototype nor requirement model were produced. Early Warning Flood Detection Systems (Basha & Rus, 2007), decision support system (DSS) (Mirfenderesk, 2009), and agent-based discrete event simulation (ABDES) evacuation framework are some studies on prevention (Hyeong Suk Na, 2014). Currently, there is no research yet done to provide solution on reallocating victims when the ECs are almost submerged. A requirement model needs to be established as a foundation to build such system. On the studies stated above, no requirement model was produced. A requirement model represents users' needs which is created through process model (Kumar, 2012; Pressman, 2010).

The specific objectives of this proposed Requirement Model of an Adaptive Emergency Evacuation Center Management (AEECM), which can be accessed from web or mobile devices are: (i) to identify the

requirements of AEECM, (ii) to develop a requirement model for AEECM, (iii) to verify and validate the propose requirement model through expert review and prototyping.

This study focuses on deriving the requirements model as is used in Kuala Krai district in Kelantan, Malaysia as a case study for AEECM, where the information on the ECs and rivers are collected. This study is on software development. A case such as an electrical outage and unavailability of internet connection are not taken into account. This model adopts a suitable optimization algorithm. However, no comparison with other algorithms is conducted.

The succeeding sections are organized as follows: Section II describes the main concepts behind this study; Section III presents the methodology used, followed by Section IV, which is the proposed system. The subsequent sections V and VI describe the verification results. Finally, the conclusion is presented.

II BACKGROUND

A. Evacuation

Many studies have been conducted to overcome, and minimize the hazards and risks of disasters. All those studies carry the same characteristics; they reflect on the necessary conditions for evacuation to be effected, persons at risks and require evacuation, safe places, and the evacuation routes to destination.

Gama et al. (2013) present a multi-period optimization model which aims at identifying the optimal location of shelters in the event of a flood disaster. A fixed number of the location of the ECs is determined in each time period and once opened it must remain opened. It assigns the victims from their residences to the ECs based on full coverage objective and a distance objective. It also determines the number of rescuing units allocated to each opened shelter.

The work by Kongsomsaksakul et al. (2005) proposes a model which can be used to determine shelter locations based on their capacity constraints in the event of flood. The model is defined as bi-level programming problem which is different in comparison to traditional location allocation model in location theory. With aims to minimize the total network evacuation time, the number and locations of ECs are determined by the planning authority. However, the researchers do not clearly state how those ECs are determined. The ECs and the route are chosen simultaneously.

Basha & Rus (2007) describe the problem of early warning system and propose sensor network with specific requirement as a solution. For instance, this sensor network monitors events covering a large area of geographic regions, roughly about 10,000 km²,

measures a wide range of varieties of variables that contribute to the occurrence of an event, and detects and predicts river flood by measuring river level, rainfall, and air temperature to detect river flooding. By monitoring this information, flooding events can be predicted. If these information imply flooding, the system will alert the authority and the community around the affected area to enable them to prepare themselves for evacuation to a safer place.

Multi-period optimization model is designed to find the optimal location shelter in the event of a disaster. This model helps by allocating victims to EC. In addition, it also determines which rescue unit to be dispatched to that specific EC. Similarly, Kongsomsaksakul et al. (2005) designed a system to fulfill the same objective as the Multi-period optimization model. In contrast, the early warning flood detection system is designed to detect flood and alert the people around the flood zone.

These combination of works, either by Gama et al. (2013) and Basha & Rus (2007) or the work by Kongsomsaksakul et al. (2005) and Basha & Rus (2007), may help the authority to evacuate the people at risk to safer places. However, as mentioned earlier, an EC which is identified as a safe place, may in fact not as safe as expected. It was reported that several ECs in Kelantan were engulfed by flood water in January 2015. It was also reported that the rescuing team was late in making the decision to reallocate the victims to other safer ECs. Therefore, this prompted the needs of having a decision support aid that enables EC staff to make quick and accurate decision to reallocate the trapped victims to the safest EC.

B. Requirement Model

There are two views in requirement modeling; structured analysis and object-oriented analysis. In structured analysis, both data and the processes that transform the data are considered as separate entities. On the other hand, object-oriented analysis integrate the entire specific data and the processes that create, read, update or delete the data and these are named with the object. Unified Modeling Language (UML) is one of the techniques that is based on object-oriented analysis and is well-known and widely used in education and academic papers (Petre, 2013). Pressman (2010) proposes a combination of both approaches which consist of four elements of requirements modeling; namely scenario based models, class models, behavioral models and flow models. According to Wiley (2003), use case diagram, sequence diagram, and class diagram have already covered 80% of requirement modeling. This statement is supported by Dennis, Wixom, & Roth (2015) who suggested that use case diagrams, class diagrams, sequence diagrams, and state diagrams are the four core techniques of UML in practice.

Based on the literature review discussed above, a requirement model of AEECM will be visualized by three cores of UML requirements modeling that consist of use case, class diagram, and sequence diagram.

III METHODOLOGY

There are five sequential phases in this study. The first phase involves gathering software requirement specification from all stakeholders and from the literature. These literature provide views on the activities during flood disasters and what solutions have been proposed by previous researches. It also describes the existing techniques used to gather the requirements, and how to present them. This information helps in gathering the software requirement from users. The interview technique is used to collect the requirement from the stakeholders. The stakeholders that are involved in this development are the District Officer (JPBD), the Administrators, the Welfare Officers, the Rescuers and the end users, i.e. the village heads (*JKK Kampung*). Requirement Definition Statement is the outcome of this phase.

The second phase involves modeling the requirements. UML techniques are used to model the requirement. These requirements are presented in Use Case Diagram, Class Diagram, and Sequence Diagram. Use Case Diagram is further clarified in Use Case Specification, whilst three design patterns are applied in creating the Class Diagram and Sequence Diagram.

The third phase includes the development of AEECM by applying Spring MVC Framework, Factory Design Pattern, and Repository Design Pattern (Johnson, et al, n.d.), (Gamma, n.d.), (Evans, 2003). Model-View-Controller (MVC) is a design pattern that separates application code in three layers, namely Model, View and Control.

The fourth phase involves verification of the requirement model (Use Case Diagram, Use Case Specification, Class Diagram, and Sequence Diagram). Undertaking verifications is to ensure the created model is reliable and the application is operating as expected. The verification involves examining the requirement model against collected data. Inspection technique review was used for verifications (Galín, 2004) and the questionnaire is used to record the feedback. The questionnaire template by Al-Tarawneh (2014) was used in creating the questionnaire for this study. The experts consist of 3 persons who are involved in verifying the model. These experts have more than 5 years of experience in evaluating requirement models. The fifth phase involves preparing the thesis and articles for publication.

IV THE PROPOSED AEECM

AEECM is proposed as a decision support tool to provide solutions for relocation of victims to other ECs when the existing centers are flooded. The proposed solution will provide information on the number of victims that are required to be transported to the new ECs. The application is developed on a web based platform and Android mobile application. The proposed solution operates using Firefly multi-objective optimization algorithm that creates an optimal schedule for the relocation of victims and resources for an EC. The AEECM application can be downloaded from Google Play and installed on Android devices.

AEECM is developed for authorities who are managing evacuation centers; system administrators, District Officers (JPDB), Welfare Departments (*JabatanKebajikanMasyarakat*), welfare officers, rescuers, and village heads (*JKK Kampung*). As a start, Kuala Krai, Kelantan is chosen, involving 109 evacuation centres from four districts; Guchil, Mengkebang, ManekUrai, and Dabong. The following are the use cases that have been identified for this system: (UC-1) Manage User Account; (UC-2) Manage Role; (UC-3) Manage Role Authorization; (UC-4) Sign In; (UC-5) Update Personal Information; (UC-6) Manage EC Information; (UC-7) Update data related to river level; (UC-8) Update Current Evacuees at EC; (UC-9) Request to close EC; (UC-10) Display Suggestion Evacuation Plan for the effected EC; (UC-11) Receive Alert Warning to Evacuate the EC; (UC-12) View Current Condition of EC; (UC-13) Manage River Information; (UC-14) Manage Station Information; (UC-15) Authorization; (UC-16) Update My Password; (UC-17) View EC on Map.

For managing an EC, a system administrator operates the information related to all ECs (name of EC, address of EC, EC's GPS location, maximum number of evacuee capacity, EC distance to other ECs, EC distance from the nearest river, *JKK Kampung* in charge at each EC, including the name and contact number). The system administrator also has to update data related to water level at every one hour by extracting information from the Department of Drainage and Irrigation website for selected rivers. He also manages the request for EC closure, either from head of villagers or as instructed by District Officers. When an EC is requested to be closed, the system will generate a reallocation plan by suggesting a list of ECs with the capacity of evacuee to be moved. A system administrator is able to view up-to-date conditions of ECs: (1) Red for ECs that are closed as they were submerged; (2) Orange for ECs that are needed to be closed due to rising water level – alert will be shown; (3) Yellow for ECs that is reaching 90% full - alert will be shown; (4) Green for ECs that have 75%

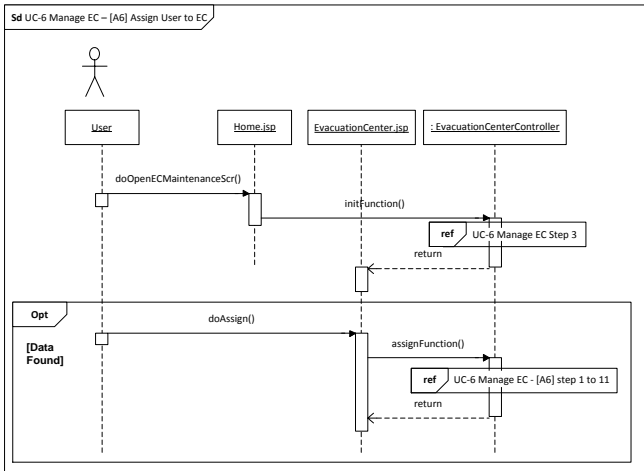

Figure 6. Sd UC-6 Manage EC – [A6] Assign User to EC

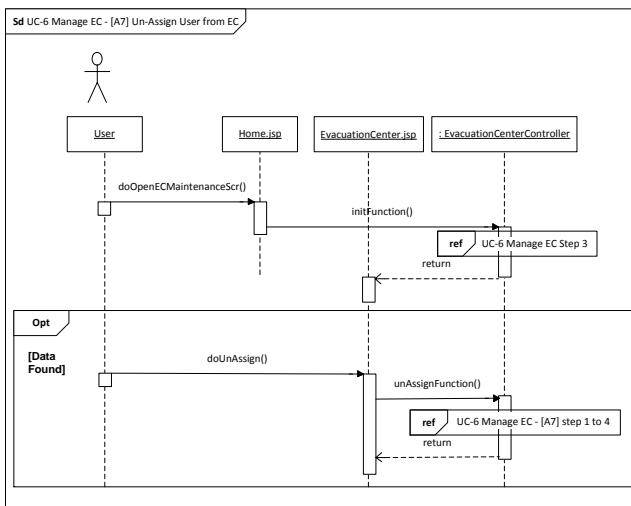

Figure 7. Sd UC-6 Manage EC – [A7] UnAssign User to EC

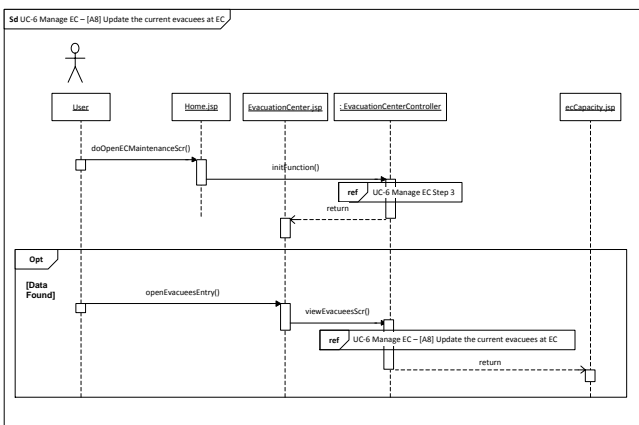

Figure 8. Sd UC-6 Manage EC – [A8] Update the current evacuees at EC

V RESULT

Verification was conducted on the proposed requirement model. Use Case Diagram, Use Case specification, Class Diagram, and Sequence Diagram

were verified by the experts that consist of three experts who have more than 5 years' experience in evaluating requirement models. The questionnaire was created to record the feedback.

Table 1 shows the results of the questionnaire answered by the expert.

Table 1. Verification Result.

No	Criteria	Majority	
		With Modification	Without Modification
1.	Correctness	4 UCs	13 UCs
2.	Ambiguity	0 UCs	17 UCs
3.	Completeness	4 UCs	13 UCs
4.	Consistency	2 UCs	15 UCs
5.	Understandability	4 UCs	13 UCs
6.	Redundancy	0 UCs	17 UCs

Based on the results, it can be said that the requirement models produced fulfill the evaluation verification criteria. However, corrections and improvements have to be made.

Based on the responses from the experts, several suggestions have been provided. The following are the suggestions to improve the requirement model: (1) equalise the number of use cases to number of use case specification (2) integrate validate user into sign in (3) state the relationship between actor and sign in use case diagram (4) use the term button on edit operation (5) state what happens behind the system (internal process) (6) state the link between use case (include and extends) (7) provide sequence diagram in high level design (8) add pre-condition on use case specification (9) Quit restricted to interface navigation (10) simplify user registration process (11) display result after generating evacuation plan (12) regenerate evacuation plan (13) provide information on use case specification on which role user will receive notification.

VI RESEARCH CONTRIBUTION

This study will contribute to the practical aspect of managing flood by providing a decision tool to assist in the management of flood , evacuation centers and flood victims in every flood-affected state. Theoretically, the study contributes to the design of flood decision aid system, whereby requirement model constructed can be used to guide designers and programmers in creating similar systems.

VII CONCLUSION

A requirement model is used to represent users' requirements. It is created through a process model. AEECM requirement model is a model derived to support a user in making decisions based on the provided solutions to reallocate flood victims to safer places. This requirement model has been verified by

the experts and a prototype has been developed in order to validate the requirement model.

In conclusion, AEECM can be a more comprehensive decision aid model if it is designed and handled carefully. There are several features of AEECM that have been identified for future improvement. One of them is a feature that requires a system administrator to manually update information of water level every one hour. As data of water level is one of the crucial information required in the decision making, the process of extracting relevant information from the Department of Irrigation and Drainage needs to be automated. This improvement can be implemented in future work.

ACKNOWLEDGMENT

This research is funded by the Ministry of Education Malaysia (MoHE) through Fundamental Research Grant Scheme [13183 (2015)]. The authors fully acknowledged MoHE and UUM for the approved fund which makes this important research viable and effective.

REFERENCES

- Al-Tarawneh, F. H. (2014). a Framework for Cots Software Evaluation and Selection for Cots Mismatches Handling and Non- Functional Requirements, 1–346. Retrieved from <http://etd.uum.edu.my/4488/>
- Basha, E., & Rus, D. (2007). Design of early warning flood detection systems for developing countries. 2007 International Conference on Information and Communication Technologies and Development, 1–10. <http://doi.org/10.1109/ICTD.2007.4937387>
- Bernama. (2015). Kaji Kawasan Baharu Untuk Dijadikan Pusat Pemindahan Banjir - Panglima ATM. Retrieved from http://web6.bernama.com/bernama/v3/bm/news_lite.php?id=1103254
- Davies, R. (2016). UN Report – Between 1995 and 2015, Flood Disasters Affected 2.3 Billion and Killed 157,000.
- Dennis;Wixom;Roth. (2015). Systems Analysis & Design 5th edition. The effects of brief mindfulness intervention on acute pain experience: An examination of individual difference (Vol. 1).
- Evans, E. (2003). Domain-Driven Design, 7873(415).
- Galín, D. (2004). Software Quality Assurance: from theory to implementation. Retrieved from <https://books.google.com/books?id=oBNLdhOoPjgC&pgis=1>
- Gama, M., Scaparra, M. P., & Santos, B. (2013). Optimal location of shelters for mitigating urban floods, 00.
- Gamma, E. (n.d.). Design Patterns CD: Elements of Reusable Object-Oriented Software (1 edition). Addison-Wesley Professional.
- Ghazali, L. B. M. S. A. R. M. A. H. (2006). Disaster Prevention and Management : An International Journal Article information :
- Hyeong Suk Na. (2014). Proceedings of the 2014 Winter Simulation Conference A. Tolk, S., 2600–2608.
- the International Federation of Red Cross and Red Crescent Societies (IFRC). (2015). World Disasters Report 2015 Focus on local actors; the key to humanitarian effectiveness.
- Ishak, R. (2014). personal communication.
- Kia, M. B., Pirasteh, S., Pradhan, B., Mahmud, A. R., Sulaiman, W. N. A., & Moradi, A. (2012). An artificial neural network model for flood simulation using GIS: Johor River Basin, Malaysia. *Environmental Earth Sciences*, 67(1), 251–264. <http://doi.org/10.1007/s12665-011-1504-z>
- Kongsomsaksakul, S., Yang, C., & Chen, A. (2005). Shelter location-allocation model for flood evacuation planning. *Journal of the Eastern Asia Society ...*, 6(1981), 4237–4252. Retrieved from <http://citeseerx.ist.psu.edu/viewdoc/download?doi=10.1.1.134.5534&rep=rep1&type=pdf>
- Kumar, S. S. D. R. (2012). INITIAL CONCEPT HOW TO DESIGN A SOFTWARE REQUIREMENT IDENTIFICATION MODEL, 3(5), 2010–2012.
- Maidin, S. S., Othman, M., & Ahmad, M. N. (2014). Information Sharing in Governance of Flood Management in Malaysia: COBIT Based Framework. *IT Convergence and Security (ICITCS), 2014 International Conference on*, 1–5. <http://doi.org/10.1109/ICITCS.2014.7021781>
- Mirfenderesk, H. (2009). Flood emergency management decision support system on the Gold Coast. *The Australian Journal of Emergency Management*, 24(2).
- Norliza Katuk, Ku Ruhana Ku-Mahamud, Norita Norwawi, S. D. (2009). Disaster Prevention and Management : An International Journal Article information : Disaster Prevention and Management: An International Journal, 4(4), 22–29. Retrieved from <http://www.emeraldinsight.com/doi/pdfplus/10.1108/09653560910965673>
- Petre, M. (2013). UML in practice, 722–731. Retrieved from <http://dl.acm.org/citation.cfm?id=2486788.2486883>
- Pressman, R. S. (2010). Software Engineering A Practitioner’s Approach. Retrieved from www.mhhe.com
- Reduction, T. U. N. O. for D. R. (2015). Disaster Statistics.
- Rod Johnson , Juergen Hoeller , Keith Donald , Colin Sampaleanu , Rob Harrop , Thomas Risberg , Alef Arendsen , Darren Davison , Dmitriy Kopylenko , Mark Pollack , Thierry Templier , Erwin Vervaeke , Portia Tung , Ben Hale , Adrian Colyer , John Lewis , Co, S. D. (n.d.). Spring MVC. Retrieved from <http://docs.spring.io/autorepo/docs/spring/3.2.x/spring-framework-reference/html/mvc.html>
- Santos, Gold, M., Merino, Madelyne, Sore, Nestley, ... Venusmar. (2013). Flood Facility Location-Allocation in Marikina City Using MCLP with Lagrange. *Asia Pacific Industrial Engineering and Management System*, 1–13.
- Wiley, J. (2003). Agile Database Techniques — Effective Strategies for the Agile Software Developer. Database.
- Yahya, H. (2014). Understanding the Knowledge Transfer Process in the Flood Management Domain.

The Design and Implementation of Malaysian Indigenous Herbs Knowledge Management System based on Ontology Model

Zulazeze Sahri, Muhd Eizan Shafiq Abd Aziz, Nazirah Ramli, and Roger Canda

Universiti Teknologi MARA (Pahang), Malaysia, {azeze, eizan, nazirahr, rogercanda}@pahang.uitm.edu.my

ABSTRACT

This paper introduces the design and implementation of an Ontology-Based Malaysian Herbal Knowledge-Based System (MiHerbs). The ontology model used in this research is based on a previous research with title, 'Malaysia Indigenous Herbs Knowledge Representation'. The research proposed an Ontology-based knowledge representation model of Malaysian indigenous herbs using Web Ontology Language (OWL). The model can be used to encode and store knowledge in a "Knowledge Base" such as database, repository or library. The model also can enhance search formulation in information retrieval of herbal knowledge with ease, fast and accurate. However, the backend databases which is based on the OWL language needs to be transformed to relational database format. The transformation from OWL to Relational database is based on the OWL2DB algorithm guideline will be further discussed in this research. Assisted by the System Development Life Cycle (SDLC) methodology, MiHerbs is expected to help herbal research agencies, private sector and government to store and share their herbal related information via the system to provide an ease information access to public or even people around the world.

Keywords: Herbal system, ontology, taxonomy, Malaysia herbs, knowledge management system

I INTRODUCTION

Herbs are one of the most useful medicinal plants with a rich and fascinating history that dates back thousands of years (Rizwan et al., 2007). In Malaysia, there are more than 2000 plant species that have healing qualities and highly potential to be commercialized with the gross profits of more than RM 5.4 billion a year could be reached from herbal related products selling (MARDI, 2015). It is important to preserve the medicinal plants since it is not only capable to bring economical importance as remedies but also has valuable knowledge of how the plant can be used, medicinal values, preparation methods and others. This is because as Malaysia moves towards the stream of global modernization, the art of traditional healing using medicinal plants suffers from the global emphasis on modern

biomedical healthcare facilities and the disinterest of younger generations in traditional knowledge and practices (Kulip, 2003, Lin, 2005). Herbal related knowledge found from ethonobotanical studies by Kulip (2003), Lin (2005), Ahmad (2008), Ahmad & Ismail (2003), Ong & Nordiana (2009), and Samuel (2010) such as medicinal uses of plants, plant part uses, preparation methods and the local name of the plants have being published widely in the internet. However, the knowledge was scattered and unorganized in the internet, only can be accessed by academic journal subscription and merely own by local people that led to difficulty in designing knowledge based system.

This paper introduces the design and implementation of Malaysian herbal knowledge-based system based on an ontology model developed by Sahri et al. (2012). The research studied the development of new ontology representation model of Malaysia indigenous herbs based on thirty herbs which were collected from previous ethonobotanical studies and experts in herbal field. The ontology was used as the knowledge representation of Malaysia indigenous herbs due to its ability to identify the concepts or classes available in the herbal domain, its relationship between concepts and instances. The ontology model can be used to encode and store knowledge in a database or "Knowledge Base" (Rosenberg, 1986). Figure 1 shows the overall view of the Malaysia indigenous herbs knowledge representation using ontology model based on identified classes and instances. The ontology design in Figure 1 shows all herbs domain classes or concepts found in this research along with the subclasses and instances. In order to ensure the knowledge model and ontology view is well defined, this paper discusses the design and implementation of a Malaysian Herbal Knowledge-Based system based on the ontology classes and relationships defined. This process requires conversion of the OWL ontology into the relational database system and involved typical Software Development Life Cycle (SDLC) in designing the system which will be discussed further.

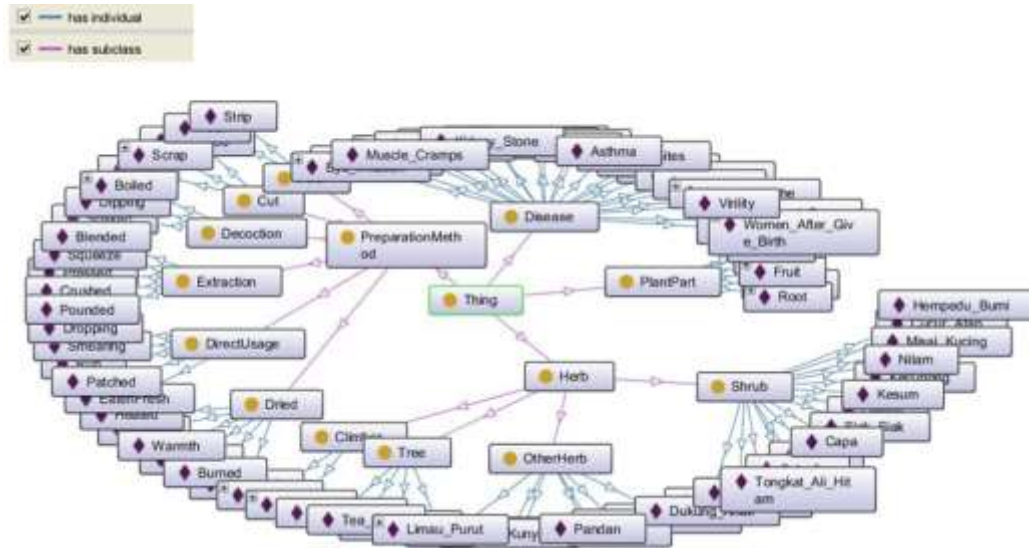

Figure 15. Malaysia Indigenous Herbs Knowledge Representation using Ontology (Sahri et. al, 2012)

In this paper, we research the ontology model developed by Sahri et al. (2012) and find the best way to develop a knowledge-based system based on the model. The system will be the end product of the developed model and the research studies, which can help people to easily access to Malaysian herbal knowledge-based system anytime and anywhere. This paper is organized as follows: Literature Review presents the conceptual understanding on ontology knowledge representation model, the software development life cycle and similar research. Methodology section describes the development of MiHerbs system from preliminary investigation and analysis on how to develop the system till the conversion process from ontology model to relational databases based on OWL2DB algorithm. The detail result of system development will be described in Result and Discussion section. Finally, concluding remarks are given in Conclusions section.

II LITERATURE REVIEW

A. Indigenous Knowledge of Medicinal Plants in Malaysia

Malaysia has been granted with estimated of 15 000 known plants species, 3700 of useful species, 2000 species with medicinal value and the balance remain unexploited MARDI (2015). This has lead Malaysia as one of the research centers with a huge biodiversity plantation. One of the focuses of research in Malaysia

is Herbs species which relate to the biotechnology is in the area of food and medicine industry (Foo, 2008). One of the focuses of research in Malaysia is Herbs species which relate to the biotechnology is in the area of food and medicine industry (Foo, 2008). In addition, Malaysia herbs are known with its medical value and economic importance with profits is more than RM 4.5 Billion a year in herbal based products (MARDI, 2015). Therefore, continuous research and development is needed in order to preserve the value of herbs. This can be done by considering the indigenous knowledge of medicinal plants uses by local people. Malaysia also can be a global player in providing products based on its natural medicinal plants. This is due the two strength points hold by Malaysia which are the plants growing in its forests and the local know-how about the numerous uses of medicinal plants; which is the indigenous knowledge (Nicholas & Lasimbang, 2004). Therefore, existing plants resources and traditional practices must be protected and expanded before forest depletion leads not only to the loss of valuable species but to the loss of valuable, indigenous knowledge as the people who hold that knowledge are displaced to other area (Ahmad, 2008). This is to show how important to preserve that knowledge by capturing, storing and disseminates the knowledge by conducting research study.

B. Ontology as a Knowledge Representation

Knowledge Representation describes the way on how particular domain knowledge can be best represented symbolically and manipulated in an automated medium by reasoning program (Brachman & Levesque, 2003). In relation to knowledge

management field, knowledge representation is required to convert tacit knowledge to explicit knowledge, and to represent the explicit knowledge in the form of suitable knowledge representation before it can be modelled and applied in knowledge sharing system such as database, repository or library (Obamsawim, 2002). There are many knowledge representation techniques in Artificial Intelligent (AI) field, the most popular and commonly used are *Logic, Production Rules, Semantic Nets and Frame* (Davis et al. 1993). However, Ontology representation has become the most preferred knowledge representation technique in recent years for a range of computer science specialties including the semantic web and bioinformatics (Thunkijjanujkij, 2009).

Ontology is a medium of expression whereby it gives ways for us to communicate with machines in order to tell them about the world (Thunkijjanujkij, 2009). Ontology can provide an organization framework about a concept which organized in a system of hierarchy and associative relations that allows reasoning about the knowledge. Generally, ontology as a graph/network structure consisting of;

- A set of concepts (vertices edges in a graph)
- A set of relationship connecting concept (directed edges in a graph)
- One set of instances assigned to a particular concepts (data records assigned to concepts or relation

Noy & McGuinness (2001) defined an ontology as a formal explicit description of concept in a domain of discourse (class or concept), properties that describe the characteristic of the concept (slots or roles), and restriction on slots (facet or role restriction). A complete Ontology with a set of individual instances of classes is able to form a knowledge base. In addition, the ontology can be used to develop the knowledge based by constructing the ontology model through the relevant concepts and their relationship. Therefore, the formalized ontology knowledge representation makes knowledge sharing and reuse possible through the knowledge based system. In contra to other knowledge representation techniques, Salem et, al (2008) found in the summary of their research that the ontology provides a robust knowledge representation technique for building a knowledge based system compared to semantic network in terms of restriction on relationship and property characteristic.

C. Knowledge Based System

Knowledge based system is one of the three components in an expert system, while another two

components are an inference engine and user interface. Knowledge based system can be defined as a system that perform a task by applying rules in (Astari et. al, 2011). The underlying concept of knowledge based system is where knowledge is acquired and represented by using any of the knowledge represented such as semantic nets, production rules or frame before it can be encoded in the system. Astari et. al (2011) stated that the advantages of knowledge based system are as follows;

- 1) Provides permanent knowledge
- 2) Can be used as decision support system
- 3) Provides explanation of recommendation
- 4) Provides fast response to problems
- 5) Provides a stable and complete responses

The Malaysian Herbal Knowledge-based system satisfies the definition of knowledge based system and its components. This is because the system development is based on an ontology knowledge representation developed by previous research and it has the components of a knowledge expert system such as knowledge base, inference engine and user interface.

D. Review on Current Research

Previous researches (Kato et al. 2009; Zakaria et al. 2014; Tungkwampian et al. 2015) have studied the use of ontology technique in developing herbal related information system. Kato et al. (2009) proposed an ontology-based E-Health system that can helps users to search for Thai herbs to cure disease. The research applied existing tools and technologies which focus on inference engine. The research employed RDF, RDF Schema, OWL to describe Thai herb knowledge and Protégé ontology editor to edit the ontology. In order to simulate the inference process, JESS inference engine and SWRL were used. The research uses Jena as their system's inference engine with the implementation of JSP Java Servlet technologies to execute Java program in Jena to infer Thai herb recommendations. Zakaria et al. (2014) suggested a lightweight ontology for herb domain which is comparatively simple and easier to construct by do not capture the semantics in the ontologies. Finally, Tungkwampian et al. (2015) uses ontology in creating conceptual knowledge and to understand the whole pictures of illness and treatment with Thai medicine plants. Then, a Thai herb database was integrated with the ontology to create the knowledge base in RDF (Resource Description Framework) format by using Ontology Application Management (OAM) framework developed by

NECTEC before it can be queried by SPARQL query facility. Comparatively, this research try to convert the Malaysia indigenous herb ontology design to relational database by using OWL2DB mechanism, rather than using existing technologies such as RDF, JESS and Jena. The successful of the conversion will enable the design of system development by using interactive AJAX Web 2.0 functionality, such as to suggest and recommend other herbs, part uses and preparation methods based on same category with the query result.

III METHODOLOGY

The overall development of MiHerbs system employs the system development life cycle (SDLC) which involves five phases namely, Preliminary Investigation and planning phases, Analysis, Design, Implementation and maintenance phase. Figure 2 depicts the common system development phases that need to be implemented in developing MiHerbs.

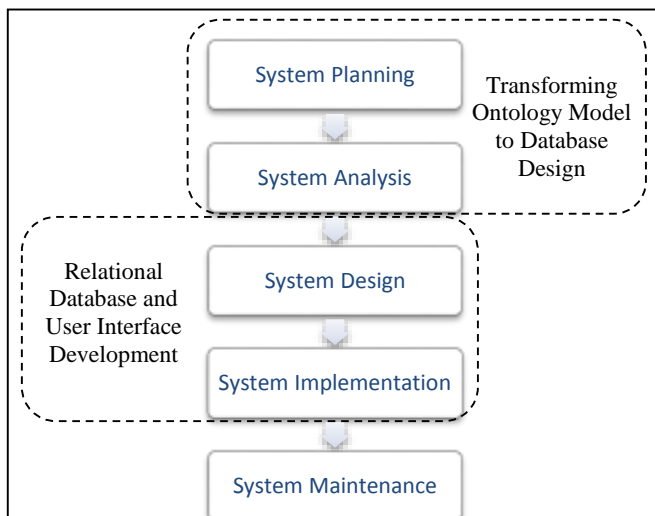

Figure 2. System Development Life Cycle

In investigation and analysis phase, the challenges in developing the MiHerbs system is the possibility to store the ontological information and processing this information by user queries. For this purpose, relational database will be used since it can cope with large amount of data. Hence, the first thing need to do is to transform the ontology representation in the form of OWL developed by sahri et al. (2012) to a relational database. This transformation is based on the outline algorithm of OWL2DB explained by Vysniauskas & Nemuraite (2006). The OWL2DB algorithm describe the process to transfer classes, properties and relationships (in ontology model) into relational database format which will result the mapping of *class to table*, *property to table relation* and *property restriction to database cardinality*. Figure 3 shows the process matching that the research need to satisfy in transforming the ontology model to

a relational database based on the characteristics as defined in the ontology model. This transformation allows the Malaysia herbs ontology can be represented in the form of relational database which include table, table relation and data set.

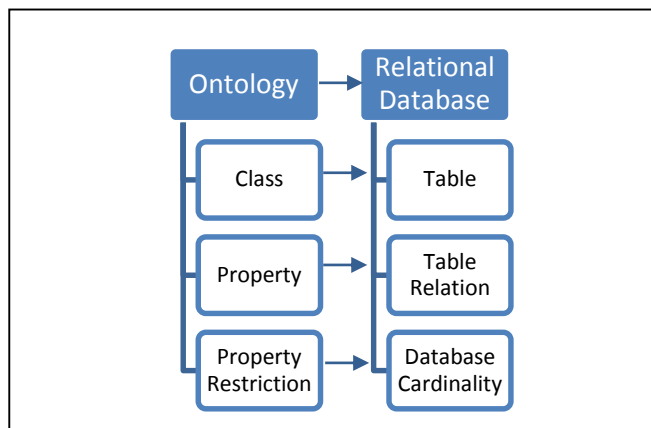

Figure 3. Transformation from Ontology Model to Relational Database Process Matching

To support the conversion from ontology model to a relational database, the research adapt the algorithm suggested by Vysniauskas & Nemuraite (2006) to map the OWL to relational schema as below:

TABLE I. OWL2DB TRANSFORMATION STEPS

Step	Description
<u>1</u>	The given OWL file is first parsed for Root classes that iterate over all the root classes.
<u>2</u>	Iterate through the root classes to determine the depth of the descendants.
<u>3</u>	The show class method is called that keeps track of the depth of the subclasses from the root and when the depth of the graph is 3 then a relation table is created for all the subclasses above it with attribute names/instances as column names.
<u>4</u>	The above step is repeated starting from the last subclass and traversing the graph and collecting the list of all the table names and column names of subclasses that are at the depth of three from the starting node.
<u>5</u>	The depth of the Union/complement/disjoint subclasses on the same level is the same.
<u>6</u>	Separate relations are created for classes that are disjoint from each other.
<u>7</u>	Once the information on tablename and corresponding attributes are collected, we need to collect the values of the instances to populate the database. The graph is parsed again to collect the values that are stored in a data structure.
<u>8</u>	Finally, a database connection is established and all the tables are created and then the values are inserted.

In design and implementation phase of the SDLC, the construction of database logical design was conducted

by using BiZagi Process Modeler and the physical relational database is constructed by using MySQL. Meanwhile, the development of overall web system interface and functionality is based on the open source framework which is PHP and Asynchronies JavaScript and XML (AJAX). AJAX technology is selected to enhance user interactivity where its allows the search result appear simultaneously during user key-in compared to normal searching which user need to click 'Submit' button to send the search keyword to database for processing. Finally, the maintenance phase will be kept in view for future research and improvements.

IV RESULT AND DISCUSSION

A. The Proposed System Architecture

The proposed system is based on knowledge-based system architecture as the objective of the research is to transform the ontology knowledge model to a system that can give easy accessibility to the Malaysian herbal knowledge. The developed system consists of three main components which are user interface for user interaction, inference engine which will derive the conclusion from the relational databases (encoded from OWL Ontology) based on the matches index that occurs in an AJAX file and relational database. The components relation can be illustrated as below Figure 4.

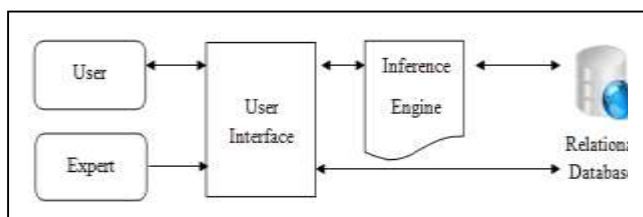

Figure 4. Proposed Architecture for MiHerbs

a) User Interface

It allows user to interact with the system find information by means of keyword searching and related concept browsing. There are two types of user which is the expert/researcher/valuator who will insert or update the herbs information and normal user who will use the system to find information insert by the expert/researcher/valuator.

b) Inference Engine

The heart of the system which accepts user input and matches the input in the database. The inference engine will try to derive the conclusion from the relational databases (encoded from OWL Ontology) based on the matches index that occurs in an AJAX file.

c) Relational Database

The relational database technology is able to provide the best facilities for storing, updating and manipulating the information of problem domain. The ontology knowledge representation developed is encoded in the knowledge based system which allows the inference engine to examine the rules.

B. Ontology Model to Relational Database

The result of transformation from the ontology model into relationship database is discussed in this section. The transformation process is based on the algorithm of OWL2DB outlined by Vysniauskas & Nemuraite (2006). Figure 5 shows the list of classes, subclasses hierarchy and its associated individual data (Disease) from Sahri et al. (2012) in OWL using Protégé 4.2. Meanwhile, the overall ontology model can be visualized in Figure 1 along with the associative relationship among classes and subclasses.

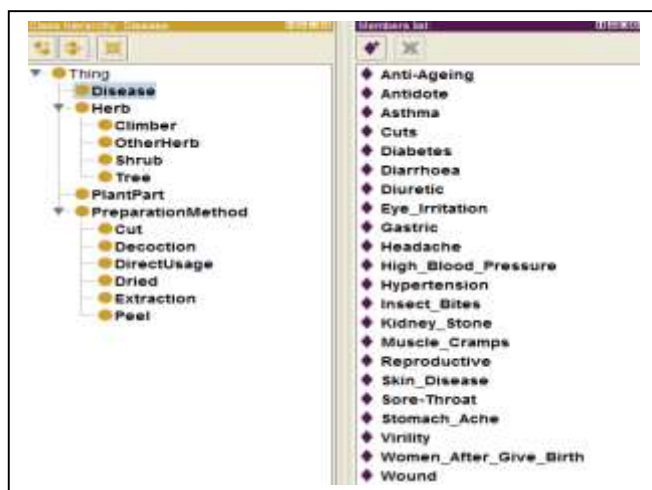

Figure 5: Class Hierarchy and Individuals View in OWL

The transformation of the OWL language into relational database by using OWL2DB algorithm allows us to convert class and subclass to table, class property to table relation such as one-to-many, many-to-many and many-to one, and also to convert property restriction to database cardinality such as Foreign-key. The final result of transforming OWL language as shown in Figure 5 to relational database schema can be seen in Figure 6 below.

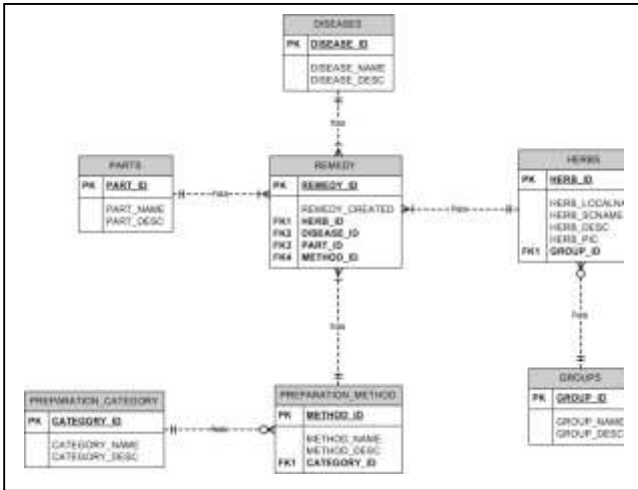

Figure 6. Transformation Result from OWL to Relational Database Schema (ERD)

There are seven tables has been created in the relational database based on the classes and subclasses defined in the OWL language. For example, *Disease* (OWL) to *Diseases* (ERD), *Herb* (OWL) to *Herbs* (ERD), Sub-Class of *Herb* (OWL) to *Groups* (ERD), *PlantPart* (OWL) to *Parts* (ERD), *PreparationMethod* (OWL) to *Preparation_Method* (ERD) and Sub-Class of *PreparationMethod* (OWL) to *Preparation_Category* (ERD). Additional Composite table, namely, *Remedy*, must be add that act as the bridge or linker between all tables based on the Primary Key (PK) defined in all tables. In this case, *Remedy* can be assumed as *Thing* (OWL) that shows all classes defined in the research is in one herbal domain and it must be related to each other. The relationship define in ERD is based on detail relationship defined in ontology model view in Figure 1. For example, Figure 1 shows that *Herb* <has subclass> of *Climber*, *Shrub*, *Tree* and *OtherHerb* can be represented in ERD as *Herbs* table has <Many to One> relationship with *Groups* (the sub table of Herbs). <Many to One> is the database cardinality that the research derived from the ontology *Property Restriction* which can be found in the OWL.

C. The Knowledge-Based System User Interface

The interface of MiHerbs system shows in Figure 8. The homepage of the system will shows a textbox that allows user to key in searching keywords such as herbs name, disease or by preparation methods and herbs parts. Since the ontology has concepts and relationship, this research is able to design a system that provide search box that allows user to find information by keywords-search. The inference engine infers the input based on the if-else rules to derive desired result from the database as below example.

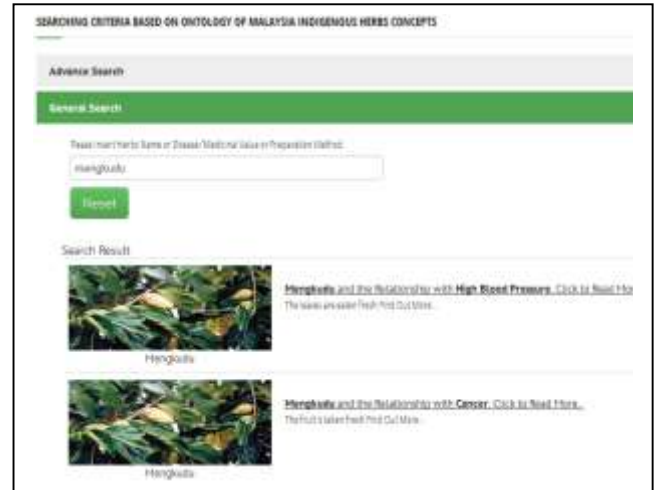

Figure 8. MiHerbs system with search box

From the query result, the system is able to suggest the related information based on the same category (Sub-Classes in OWL) of the existing result search. The result also can be used to retrieve every category of documents in a particular domain written in all languages. For example, when user search for the keyword “Mengkudu”, the result will shows that Mengkudu falls under herbs category “Tree” and is able to cure “High Blood Pressure”. Then, the system is able to suggest all herbs that fall under category “Tree” and all herbs that can cure “High Blood Pressure”. This example can be further view in Figure 9. The result page not only contains the information on selected herbs, but also will recommend other herbs which in the same category of herb which are Tree.

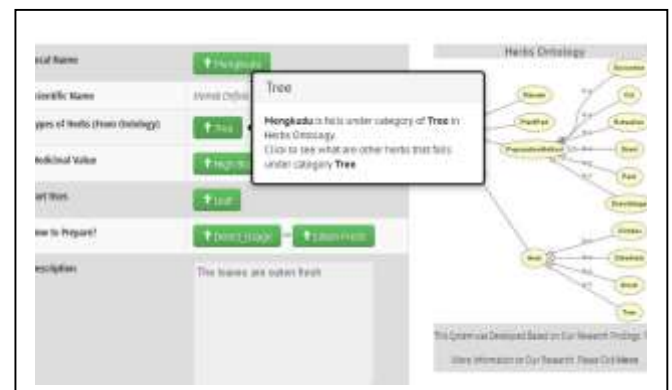

Figure 9. Result page with recommendation of other Herbs that falls under same category

V SYSTEM LIMITATION

The limitation of the system is identified especially in the search facilities that only can accept ‘keyword’ based queries rather than multiple keywords or sentences. This weakness is due to the way ontology design and model the domain in the form of class name and its associated elements mostly in the form of

individual keywords. Further study will be conducted in order to rectify the weaknesses.

VI CONCLUSION

This research succeeded in building a Malaysian Herbal Knowledge-Based system in an effort to preserve the Malaysian treasures and provide searching facilities for future generation. The development of MiHerbs system also validate that the Malaysia indigenous herbs knowledge representation using ontology model is able to encode and store knowledge in a database as well as reasoning rules that support the processing of information retrieval.

ACKNOWLEDGMENT

We thank the Institute of Research Management and Innovation (IRMI) of Universiti Teknologi MARA (UiTM) for supporting this research through the Internal Research Acculturation Grant Scheme (iRAGS) with project code number 201215160004.

REFERENCES

- Rizwana, A., Q., & Muhammad, A., G. (2007). *Indigenous Knowledge of Selected Medicinal Wild Plants of District Attock, Punjab, Pakistan*. 39(7), 2291-2299.
- MARDI (2015). Retrieved Februari, 2015 from <http://www.mardi.gov.my/web/guest/skop-penyelidikan15>
- Kulip, J. 2003. An ethnobotanical survey of medicinal and other useful plants of Muruts in Sabah, Malaysia. *Telopea* 10(1): 81–98.
- Lin, K. W. (2005). Ethnobotanical Study of Medicinal Plants Used by the Jah Hut Peoples in Malaysia *Indian Journal of Medical Sciences*, 59(4), 156-161.
- Ahmad, F. (2008). *Robotic Technology Malaysia*. Retrieved November 2011, from ssc.undp.org/uploads/media/Robotic_Technology_Malaysia.pdf
- Ahmad, F., & Ismail, G. (2003). Medicinal Plants Used by Kadazandusun Communities Around Crocker Range. *ASEAN Review of Biodiversity and Environmental Conservation (ARBEC)*.
- Ong, H. C., & Nordiana, M. (1999). Malay Ethno-Medico Botany in Machang, Kelantan, Malaysia. *Fitoterapia* 70(5), 502-513. M. Young, *The Technical Writer's Handbook*. Mill Valley, CA: University Science, 1989.
- Samuel, A. J. S. J., Kalusalingam, A., Chellapan, D. K., Gopinath, R., Radhamani, S., Husain, A., Muruganandham, V., & Promwichit, P. (2010). Ethnomedical Survey of Plants Used by the Orang Asli in Kampung Bawong, Perak, West Malaysia. *Journal of Ethnobiology and Ethnomedicine*. Retrieved November 2011, from <http://www.ethnobiomed.com/content/6/1/5>
- Sahri, Z., Nordin, S., & Harun, H. (2012). Malaysia Indigenous Herbs Knowledge Representation. Knowledge Management International Conference 2012, Johor Bahru, Malaysia. Article in a conference proceedings.
- Rosenberg, J. M. (1986). *Dictionary of Artificial Intelligence and Robotic*. New York: Willey.
- Foo, Y. M. (2008). *Electronic dictionary for Herb's plant*. Universiti Malaysia Perlis
- Kato, K., Maneerat, N. & Varakulsiripunth, R. (2016). *Ontology-based E-health System with Thai Herb Recommendation*. Tohoku University.
- Tungkwampian, W., Theerarungchaisri, A. & Buranarach, M. (2015). Development of Thai herbal medicine knowledge base using ontology technique. *The Thai Journal of Pharmaceutical Sciences*, 39 (3), 102-109.
- Zakaria, H., Hassan, R., Othman, R., M., Asmuni, H. & Shah, Z., A. (2014). A Study of Lightweight Ontology for Herb Domain. 2014 8th Malaysian Software Engineering Conference (MySEC).
- Nicholas, C. & Lasimbang, J. (2004). *Biodiversity and Indigenous Knowledge System in Malaysia*. Center for Orang Asli Concern, Subang.

Estimating the Right Allocation of Doctors in Emergency Department

Mohd Ridzwan Zulkifli¹, Muthukkaruppan Annamalai¹, Kassim Isahak¹ and Rashidi Ahmad²

¹Universiti Teknologi MARA (Shah Alam), Malaysia, ridz.binary@gmail.com, {mk; isahak}@tmsk.uitm.my,

²University Malaya Medical Centre, Kuala Lumpur, Malaysia, rashidi@ummc.edu.my

ABSTRACT

Emergency Department (ED) provides acute care to various medical and surgical conditions. In a typical ED, there are three management zones: Red, Yellow and Green zones for attending patients with critical, semi critical and non-critical illness and injuries, respectively. The problem is staffing each zone with adequate doctors (the scarce resource) to ensure the ED is able to function as a reliable organisation. Consequently, this paper presents a useful way to estimate the right allocation of doctors in ED through Discrete-Event Simulation (DES) implemented using Arena. The estimation is based on patients' waiting time and doctors' utilisation rate. The basis of the simulation is drawn from Queuing Theory and Theory of Constraints. The case study is the University Malaya Medical Centre (UMMC). Seven scenarios based on real-life situations are simulated and analysed. The results show that the right allocation to the Red, Yellow, and Green Zones in UMMC-ED are two, four and two doctors, respectively. The findings will serve as the basis to plan for future work on repositioning relatively free doctors from one zone to another zone that is facing temporary overcrowding emergencies.

Keywords: Emergency Department, Discrete-Event Simulation, Queuing Theory, Theory of Constraint.

I BACKGROUND

Emergency Department (ED) is a facility in hospital that operates around the clock to provide initial treatment with illnesses and injuries that could be life threatening and require immediate attention. In a typical ED such as in our case study, the University Malaya Medical Centre (UMMC), the arriving adult patients are triaged according to their severity, and assigned to one of the three zones. Patients with critical condition will be directed to the Red zone, semi critical conditions to the Yellow zone, and non-critical conditions to the Green zone. They urgency of care is reflected in the maximum waiting time that is allowed for patients to receive attention and treatment as shown in Table 1.

ED is staffed with few doctors who are supported by many paramedics and nurses. The healthcare management in ED is highly dependent on the doctors because only they are authorised to make

healthcare decision for patients. Therefore, a key challenge in the management of ED is to estimate the right number of doctors to allocate in each zone especially during the peak hours. On one hand, fewer doctors in ED will cause insufficient capacity to supply demand, which leads to doctors' fatigue and starve patients needing emergency care. On the other hand, many doctors in ED will cause excessive capacity to supply demand, which leads to the under-utilisation of the scarce resource. Hence, staffing each zone with the right number of doctors is necessary to ensure the doctors are maximally utilised and patients are treated within the allowed waiting time. According to Martin, a good utilisation rate of resources in the service sector is between 70 and 80 percentages (Martin, 2010).

Table 9. Maximum Patient Waiting Time for Each Zone

Zone	Description	Max. Waiting Time
Red	Critical – Immediate threat to life	0 minute
Yellow	Semi Critical – Prompt care needed	30 minutes
Green	Non-Critical – Can wait	90 minutes

Each ED management zone has random arrival of patients, multiple channels of arrival, random cases of patient severity and multiple stages of management. While some facilities for investigation are available within a zone, some are shared in common. These factors increase the complexity to estimate the right allocation of doctors to each zone.

In dealing with the above complexity, we resort to Queuing Theory (QT) and Theory of Constraints (ToC) to construct a Discrete-Event Simulation (DES) model. The computer model is executed and studied for various scenarios in order to estimate the doctors required in ED.

II CASE STUDY

Doctors are the key resources in ED. The doctors in UMMC-ED comprise specialists, physicians and medical officers, who are allocated to the Red, Yellow and Green zones, respectively. Specialist is a doctor who is specialised in emergency medicine and has vast experience in emergency care. Physician has medical and surgical skills, and is on the way to become a specialist. Medical officer is a person who has a medical degree qualification and registered to Malaysia Medical Council. There are fewer specialists in ED compared to physician and medical officers. In teaching hospitals like UMMC, the

medical officers consist of trainee doctors who are supervised by specialists and/ or physicians.

The doctors work in shifts. For example, in UMMC-ED, the morning, evening and overnight shifts are 0800 to 1500 (7 hours), 1500 to 2200 (7 hours) and 2200 to 0800 (10 hours), respectively. It has been observed that the morning and evening shifts are more crowded compared to the overnight shift; a reason for the longer overnight shift period.

In addition, the following constraints have been stipulated for estimating the allocation of doctors in UMMC-ED. Each zone is allocated a minimum number of two doctors per shift. The number of doctors can be increased to a maximum of nine by involving additional physicians and medical officers, more of the latter.

III RELATED WORK

We can regard the estimation of the doctors required in ED during peak hours as a form of capacity planning of vital resource (i.e., doctors) to support the ED management.

Computer simulation is a popular tool used by decision makers to analyse the constructive management of resources in complex systems, but the simulation model about a process that is supported by theory and practice must be first constructed (Maria, 1997). In this work, the basis of the ED simulation model is drawn from two theories: Queuing Theory (QT) and Theory of Constraints (ToC).

QT has been applied in scheduling and staffing in healthcare applications (Fomundam & Herrmann, 2007). The theory relates the queue discipline and network measuring variables such as arrival time, waiting time, queue length, service time, service channel, to define the services and their relationships. Such measures are fundamental to the understanding of patient flow and to estimate staff allocation in ED. For example, Exadaktylos, Evangelopoulos, Wullschleger, Bürki, & Zimmermann (2008) have studied the minimum number of staff required is based on the average patient arrival and average service time. In Green, Soares, Giglio, & Green (2006), the estimation of staff is based on average service time and the average number of patients who left without being seen. In McManus, Long, Cooper, & Litvak (2004), the bed utilisation is used as an additional measure.

Besides scheduling and staffing, there are also works that applied QT to reduce queue waiting time or sometimes referred to as the length of stay (LoS) (Lewis & Edwards, 2015). In the context of ED, the LoS refers to the period between patient arrival and disposition (see Figure 1). For example, Alavi-Moghaddam, Forouzanfar, Alamdari, Shahrami,

Kariman, Amini, & Shirvani (2012) applied the QT to study the effect of LoS to changing operational strategies in ED.

ToC is implemented as a concept of maximising output by optimising operation or services (Krajewski, Ritzman, & Malhotra, 2006). ToC has primarily facilitated to resolve bottlenecks in manufacturing, and lately in service industries such as banking (Simsit, Günay, & Vayvay, 2014). Aguilar-Escobar, Garrido-Vega, & González-Zamora (2015) is a more recent work that has applied ToC to alleviate storage and storing bottlenecks in the management of hospital medical records. There is little work that considered the application of ToC in ED. Ahmad, Ghani, Kamil, & Tahar (2010) proposed to apply the approach of ToC to sub-ordinate resources from related services in order to solve conflict of supply and demand in ED. Groop, Reijonsaari, & Lillrank (2011) applied ToC to measure the operational criteria in order to assess how doctors' qualifications affect ED operation.

The processes in ED management can be viewed as discrete events. Discrete Event Simulation (DES) has been applied in ED. For example, DES has been applied to study ambulance diversion to solve overcrowding (Lin, Kao, & Huang, 2015). The issue to relieve overcrowding is also studied by Zeinali, Mahootchi, & Sepehri (2015) through changing the quantity of resources. In Venugopal, Otero, Otero, & Centeno (2012), DES is applied to study how bottlenecks in ED are influenced by changing staffing scenarios.

Agent-based Simulation (ABS) is an alternative simulation paradigm. It shifts the focus of simulation from process-oriented (as in DES) to goal-oriented. In the context of ED, ABS has been applied to better understand staffing and throughput. As an example, Taboada, Cabrera, Iglesias, Epelde, & Luque (2011) used ABS to investigate scenarios of ED staffing that fit patient arrival. Similarly, some of the authors of this paper have previously studied patients LoS in emergency room in the context of re-triage through ABS (Rahmat, Annamalai, Halim & Ahmad, 2013)(Annamalai, Khairani, & Rahmat, 2015).

IV RESEARCH METHOD

Our simulation method follows the six general steps prescribed by Zeltyn, Lauterman, Schwartz, Moskovitch, Tzafrir, Basis, & Shtub (2011).

- A. Model Development
- B. Model Verification
- C. Data Collection
- D. Model Integration
- E. Model Validation
- F. Simulation Analysis

A. Model Development

In this step, the patient flow model that is vital to the understanding of the ED management is developed. The model is completed by listing all the related services in ED, and the connections between them. The service queues that are due to bottlenecks are identified in the model.

The UMMC-ED patient flow model is shown in Figure 1. It shows the main services: patient arrival, triage, management, investigation and disposition. The suffix 'R', 'Y' and 'G' at the end of Management and Disposition distinguishes the services in the Red, Yellow and Green zones, respectively. The asterisked labels refer to services with queue.

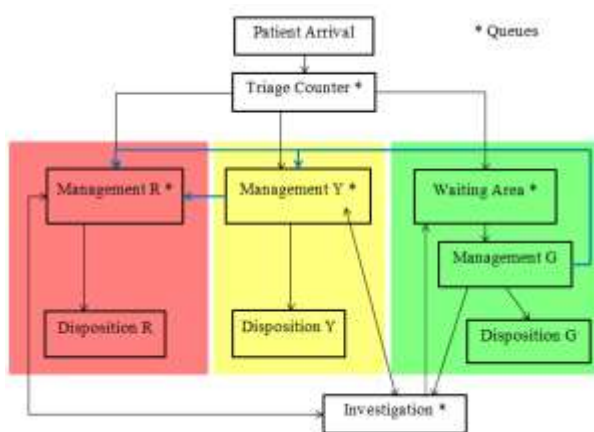

Figure 16. Patient Flow Model

Patient arrival indicates the point when the patient arrives at ED. This is followed by patient registration, which is not shown in the model because it does not contribute to the outcome; the registration of patients is often done by someone other than the patient. The patients will be triaged based on the severity of their health conditions and directed to one of the three zones for management.

Because Red and Yellow zone patients require immediate and urgent medical attention, they are moved to the bed immediately. Yet, there is an implicit priority queue of the arrivals. The Green zone patients queue for their consultation in the waiting area.

The management in ED is performed in blocks of procedures; also known as stages. Each stage comprises three activities: Diagnosis, Treatment and Prognosis. Diagnosis is the procedure to identify the cause of problem or illness by examining the patient. Treatment is a medical or surgical procedure to cure a patient. Prognosis is to predict the outcome of the treatment, which is confirmed through monitoring and/ or investigation that follows. Patients in the Red and Yellow zones undergo up to a maximum of three management stages, after which the case is escalated for intensive care (the stages are not shown in the

model). Sometimes critical patients wheeled into the Red zone require resuscitation prior to diagnosis. Resuscitation is included as a part of first management stage.

Investigation is needed when doctor requires certain diagnostic tests to be carried out in the central laboratory to verify or confirm the presence of a disease. There are three main investigations: Blood test, Urine test and Imaging (X-Ray, CT-Scan, MRI, etc). The Blood and Urine tests are normally conducted internally in the Red and Yellow zones. If a Green zone patient is directed to the laboratory, he or she will rejoin the queue in the waiting room for post-investigation management.

The flows in all three zones end with Disposition, i.e., ED exit point. The disposed patient may go home, sent to ward for observation, sent to another hospital for specialised care or sent to the intensive care unit.

Nine queues have been identified in the model (asterisked services): Triage Counter, 1st Stage, 2nd Stage and 3rd Stage Management in the Red zone (waiting for doctor's attention on bed), 1st Stage, 2nd Stage and 3rd Stage Management in the Yellow zone (waiting for doctor's attention on bed), Green Zone (waiting area), and Investigation (waiting to perform Imaging, Urine and Blood tests).

B. Model Verification

The detailed patient flow model is verified in terms of the model details and validated to represent the real-world environment with the help of doctors, and later cross-checked with the administrators in the UMMC-ED. Subsequently, their cooperation is sought for collecting the primary and secondary data with which computer simulation model is constructed.

C. Data Collection and Analysis

The simulation is based on the data collected at a number of points in the ED services shown in Figure 1. The data is collected from two sources, primary and secondary source.

Primary source is data collected manually using time stamping device. Secondary source is data that is extracted from the live emergency medical records generated by the Patient Management System with permission; some were collected from the patient registration logs maintained by the ED administration, while others were obtained from the ED administration reports.

The collected data are cleaned to remove the outliers, and cross-verified before analysing them to produce the probability distributions described in the following subsections. Note that the time units are specified in minutes unless indicated otherwise.

Patient Arrival. We began by investigating the patient arrival at ED on weekdays and weekends, and during different work shifts. The data is collected manually using time stamping device and the sample size is 234. Figure 2 shows four samples of inter-arrival frequencies at UMMC-ED, on weekdays and weekends.

Consequently, we checked the similarity of weekday and weekend patient arrival. We performed a Z-score test on the data, and the P-value is 0.344. Therefore, we can conclude that at $\alpha = 0.05$, there is no significant difference between the arrival patterns on weekdays and weekends.

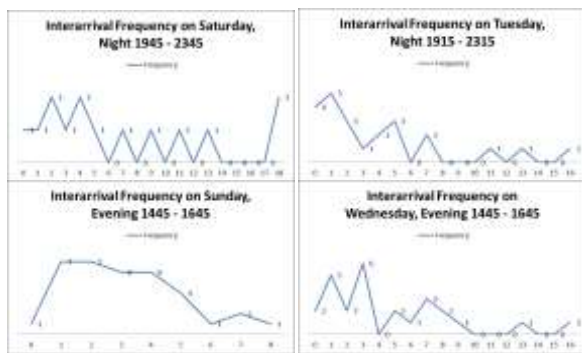

Figure 17. Inter-arrival of Patients at UMMC-ED

The patient arrival follows *Exponential* distribution specified by the function,

$$f(x) = \begin{cases} \frac{1}{m} e^{-x/m}, & x > 0 \\ 0, & \text{otherwise} \end{cases} \quad (1)$$

where x is data value and m is mean; $m = 4.41$

The challenge is to manage the patients during the peak hours. In order to determine the peak hours in ED, the patient registration logs are analysed. The graph in Figure 3 shows the average patient arrival in ED in November 2015 (sample size of 7276). It can be seen that the number of incoming patients rises to 6 patients per hour around 0800 hours (i.e., at the beginning of the morning shift) and remains at or above this limit until midnight. The trend is similar for both weekdays and weekends except for a slight dip around 1800 hours on weekdays. Consequently, we set the range from 0800 to 2400 (16 hours) as the peak hours in this study.

Triage. Patients are triaged according to their severity, and assigned to one of the three zones. We used the patient registration logs to determine the proportion of patients going to red, yellow and green zones. The sample size is 53,291 records, which encompasses the data logged for six months duration, i.e., from March to August 2015. Our analysis shows that 7% of the patients are assigned to the Red zone, 26% to the Yellow zone, and 67% to the Green zones. It can be seen that the number of patients

admitted to the Red, Yellow and Green zones are approximately in the ratio of 1 : 3.7 : 9.6.

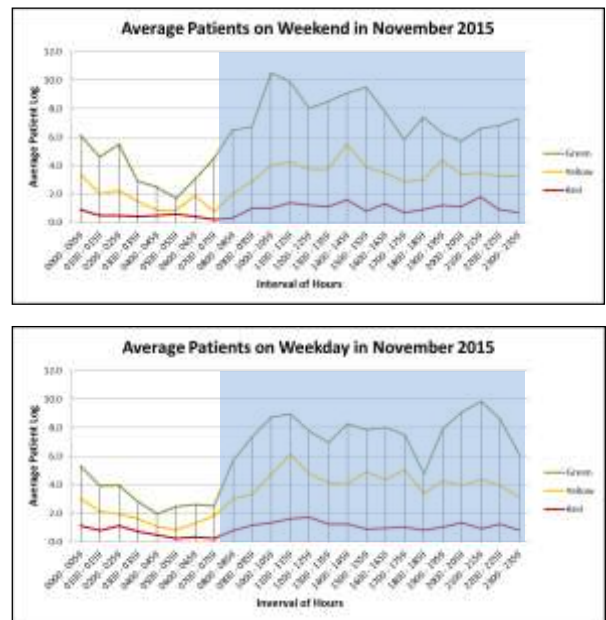

Figure 18. Peak Hours in UMMC-ED (0800 to 2400)

Next, we determine the probability distribution of the time required for triage processing. We analysed the July 2015 triage records; the sample size is 1974 records. The cleaned sample data follows *Beta* distribution, specified by the function,

$$f(x) = \begin{cases} \frac{x^{\beta-1}(1-x)^{\alpha-1}}{B(\beta,\alpha)}, & 0 < x < 1 \\ x, & \text{otherwise} \end{cases} \quad (2)$$

where x is data value, α is shape parameter and β is scale parameter; $\alpha = 1.75$, and $\beta = 1.44$

B in the above function is the complete beta function,

$$B(\beta, \alpha) = \int_0^1 t^{\beta-1}(1-t)^{\alpha-1} dt \quad (3)$$

Management in Red Zone. Patients can go through up to three stages of management in the Red Zone. The sample data is captured from the live emergency medical records (EMR) during the peak hour period (0800 to 2000) over two days, i.e., on 19 August 2015 and 24 September 2015. The sample has 27 records. The probability distribution of the 1st Stage management in the Red zone follows *Weibull* distribution specified by the function,

$$f(x) = \begin{cases} -\alpha\beta^{-\alpha}x^{\alpha-1}e^{-\left(\frac{x}{\beta}\right)^\alpha}, & x > 0 \\ 0, & \text{otherwise} \end{cases} \quad (4)$$

where x is data value, α is shape parameter and β is scale parameter; $\alpha = 1.08$ and $\beta = 67.4$

Both the 2nd and the 3rd Stage managements follow *Beta* distribution specified by the probability function

given in (2). For the 2nd Stage Management in the Red zone, $\alpha = 0.654$ and $\beta = 0.45$, while for the 3rd Stage Management in the Red zone, $\alpha = 0.371$ and $\beta = 0.558$

Management in Yellow Zone. Like in the Red zone, the patients in the Yellow zone can also go through up to three stages of management. The sample data is captured from the EMR during the peak hour period (0800 to 2300) on 19 August 2015. The sample has 41 records. The probability distribution of the 1st Stage management in the Yellow zone follows the *Weibull* distribution specified by the function described by equation 4, where the shape and scale parameters are $\alpha = 1.34$ and $\beta = 64$, respectively

The 2nd Stage management follows *Triangular* distribution specified by the function,

$$f(x) = \begin{cases} \frac{2(x-a)}{(m-a)(b-a)}, & a \leq x \leq m \\ \frac{2(b-x)}{(b-a)(b-m)}, & m \leq x \leq b \\ 0, & \text{otherwise} \end{cases} \quad (5)$$

where x is data value; and, a , m and b are the minimum, mode and maximum values, respectively; $a = 18$, $m = 35$, and $b = 154$.

The 3rd Stage management follows *Uniform* distribution specified by the function,

$$f(x) = \begin{cases} \frac{1}{b-a}, & a \leq x \leq b \\ 0, & \text{otherwise} \end{cases} \quad (6)$$

where x is data value; and, a and b are the minimum and maximum values, respectively. The values of x are between a and b ; $a = 37$ and $b = 162$.

Management in Green Zone. Patients in the Green zone go through a single stage management, where the pre- or post-investigation managements are treated alike. The sample data is obtained from the patient registration logs recorded in July 2015. The sample size is 2926 records. The cleaned Green zone management sample data follows *Beta* distribution specified by the probability function given in (2), where the shape and scale parameters are $\alpha = 1.33$ and $\beta = 0.979$, respectively.

Investigation. The investigation data is organised according to the zones (i.e., Green, Yellow and Red) and by the types of investigation (i.e., Imaging, Urine and Blood tests). The sample data is captured from the patient registration logs recorded in July 2015. The sample contains 2676 (Green Imaging), 2285 (Yellow Imaging), 751 (Red Imaging), 1375 (Green Urine) and 474 (Green Blood) records. The Urine and Blood tests are performed internally in the Red and Yellow zones. As in the previous cases, the samples are cleaned to remove the outliers.

The Imaging investigation for Green Zone follows *Exponential* distribution specified by the probability distribution function given in (1), where mean $m = 13.5$

The Imaging investigation for Yellow Zone follows *Gamma* distribution specified by the function,

$$f(x) = \begin{cases} \frac{\beta^{-\alpha} x^{\alpha-1} e^{-x/\beta}}{\Gamma(\alpha)}, & x > 0 \\ 0, & \text{otherwise} \end{cases} \quad (7)$$

Γ in the above function is the complete gamma function,

$$\Gamma(\alpha) = \int_0^{\infty} t^{\alpha-1} e^{-t} dt \quad (8)$$

where the shape and scale parameters are $\alpha = 1.33$ and $\beta = 1.97$, respectively.

The Imaging investigation for Red Zone also follow *Gamma* distribution specified by the probability function given in (7), where $\alpha = 1.65$ and $\beta = 0.594$

Both the Urine and Blood investigations in the Green zone follow *Log Normal* distribution specified by the function,

$$f(x) = \begin{cases} \frac{1}{\sigma x \sqrt{2\pi}} e^{-(\ln(x)-\mu)^2/(2\sigma^2)}, & x > 0 \\ 0, & \text{otherwise} \end{cases} \quad (9)$$

where x is data value; and μ and σ are the log mean and the standard deviation values, respectively.

For the Urine investigation in the Green zone, $\mu = 9.83$ and $\sigma = 15.9$; while for the Blood investigation, $\mu = 18.7$ and $\sigma = 18.2$

D. Model Integration

The ED management model is implemented in Arena. The ED management services are divided into three zones: Green, Yellow and Red. Each of the zonal services is a sub-model of the integrated management model. The services in the Yellow and Red zones are further subdivided into three stages: 1st, 2nd and 3rd stage managements. Each management stage is a sub-model of the corresponding Red and Yellow sub-models.

We configured the Arena implementation parameters according to the probability distributions described in the previous section. The simulation time period is set from 0800 to 2400, i.e., the during the peak hours. Therefore, the simulation will cover the whole of morning and the evening shifts, but just the first two hours of the overnight shift.

Further, the simulation is governed by the following assumptions:

- Scenario depicts the situation in ED on a normal day, i.e., not while public holiday or during epidemic disaster (when overcrowding is expected).

- Patient will complete the whole journey from arrival at ED to disposition from ED, i.e., there is no 'leave without being seen' incident.
- Doctors will attend to only one patient at any one time, i.e., no doctor may be simultaneously present at more than one patient side.
- A doctor is selected at random to attend to a patient based on their availability at the time of assignment.
- The clinical supervision and training by the specialists and physicians in the Red and Yellow zones are disregarded.
- Laboratory is a central investigation point for investigations related to Blood, Urine and Imaging. It will be manned by two assistants at all time.

E. Model Validation

The model is validated to ensure it has been correctly integrated and configured in Arena. The data used to fit the model is validated against the ED administration's estimates, as well as alternative sample data in hand, which is spelt out in Table 2.

Table 2. Model Validation

ED Service	Validation Data
1. Patient Arrival	Patient registration log records
2. Triage Average processing time	Observation (samples collected manually using time stamping device) and estimation of triage time by the ED administration
3. Management R Average processing time	Estimations supplied by the ED administration
4. Management Y Average processing time	
5. Management G Average processing time	Analysis of alternative sample data obtained from the patient registration logs, and the estimations supplied by the ED administration
6. Investigation Average processing time	

F. Simulation Analysis

We began the simulation analysis using a default scenario of six (6) doctors per shift, i.e., two doctors allocated to each zone in each shift. Consecutively, we modified the scenario by adding doctors until two predetermined constraints are satisfied, i.e., doctors are maximally utilised and patients waiting time is reasonable. We regard doctors are maximally utilised when they work between 70 and 80 percentages of the time in a shift. Patients waiting time can be considered reasonable if on the average they have to wait no longer than the allowed maximum waiting time to receive attention (as shown in Table 1).

The results of the analysis are summarised in Table 3. In total, seven scenarios have been studied to determine the right allocation of doctors in ED during the peak hours (0800 to 2400) that span over three shifts. The labels AM, PM and ON are abbreviations for the morning (0800 to 1500), evening (1500 to 2200) and the first two hours of the overnight (2200 to 2400) shifts, respectively. The average patient waiting time in the Red and Yellow zones are organised according to their individual 1st, 2nd and 3rd management stages labelled S1, S2 and S3, respectively. The patients' waiting time under each stage is averaged across the simulation period (0800 to 2400).

Table 3. Results of Simulation Analysis

Scenario		Allocated Doctors	Avg. Doctors' Utilisation Rate			Avg. Patients' Waiting Time		
No.	Zone		A M	P M	O N	S1	S2	S3
1	R	2	64	62	44	17	18	13
2	Y	2	97	110	100	18	20	14
3		3	93	107	93	76	79	75
4		4	84	90	57	23	20	19
5		5	56	49	40	10	10	8
6	G	2	72	35	31	6	NA	NA
7		3	55	11	10	1	NA	NA

V DISCUSSION AND CONCLUSIONS

The results show that the morning and evening shifts are the doctor-critical shifts, which will be the focus in the ensuing discussion. The Yellow zone is the doctor-critical zone in the ED, which is apparent in the number scenarios that are needed to study the allocation of doctors in this zone. The consecutive scenarios also show that the patients' waiting time is more sensitive to the addition of doctors compared to the doctors' utilisation rate.

The default number of two doctors allocated to the Red zone is adequate, yet the doctors appear to be under-utilised in the zone (average utilisation rate around 57%). However, the slack may be justified due to the clinical supervision and training provided by the specialists, which are not taken into consideration in the simulation model. Since the patients should be attended to immediately in the Red zone, the average waiting time (approximately 15 minutes) raises some concern. A probable explanation for the late response by doctors may be attributed to the management of the critical patients in the Red zone. These patients often need to be resuscitated and stabilised by paramedics before attended to by a doctor for diagnose and treatment.

Likewise, the results show that allocation of the default number of two doctors to the Green zone satisfies the predetermined constraints. The average

doctor utilisation rate is only slightly above 50%. Even though the number of doctors is just right during the morning shift, their utilisation rates are very low during the evening and night shifts. We also draw attention to the average waiting time of patients in the Green zone, which is only 6 minutes. However, this does not mirror the long queue typically observed in the waiting area. There appears to be considerable time lag between management of consecutive patients in the Green zone. The findings warrant the need for UMMC-ED to review the operating procedure of patient management in the Green zone.

Our results show that at least four doctors need to be allocated to the Yellow zone in order to satisfy the doctors' utilisation rate and patients waiting time constraints. Even though the average utilisation rate is 77%, the high utilisation rate of 87% during the day shifts is unjustifiable especially when the physicians' additional supervisory role has not been taken into consideration in the simulation model. On the other hand, increasing the number of doctors to five is also not acceptable because the addition causes the average utilisation rate of doctors to fall below 50%; and, the waiting time of patients also drop to 10 minutes (much less than the allowed waiting time of 30 minutes). Consequently, we propose to allocate two doctors to the Red and Green zones, and four doctors to the Yellow zone. We plan to deal with the high utilisation rate of doctors in the Yellow zone by repositioning doctors who are free in Red and Green zones for a period of time, particularly during the day shifts. This is slated as our future work.

ACKNOWLEDGMENT

The authors are most grateful to Dr. Muhaimin Noor Azhar, Dr. Aida Bustam, Dr. Khairul Azri and Mr. Harminder Singh for their help during data collection and interpretation. We thank Mr. Shamsul Bahari and his PEMANDU team for giving access to their organised patient registration log records.

We acknowledge Universiti Teknologi MARA (UiTM) for support of this work, which is funded under the Malaysian Ministry of Higher Education's Exploratory Research Grant Scheme (reference number: ERGS/1/2013/ICT07/UITM/02/02).

REFERENCES

Aguilar-Escobar, V. G., Garrido-Vega, P., & González-Zamora, M. M. (2015). Applying the theory of constraints to the logistics service of medical records of a hospital. *Investigaciones Europeas de Dirección Y Economía de La Empresa*, 1–8. Retrieved from <http://doi.org/10.1016/j.iiedee.2015.07.001>

Ahmad, N., Ghani, N., Kamil, A., & Tahar, R. (2010). *A framework for*

emergency department capacity planning using system dynamics approach and the theory of constraints philosophies. Proceedings of the 24th European Conference on Modelling and Simulation, Kuala Lumpur, Malaysia.

Alavi-Moghaddam, M., Forouzanfar, R., Alamdari, S., Shahrami, A., Kariman, H., Amini, A., & Shirvani, A. (2012). Application of queuing analytic theory to decrease waiting times in emergency department: does it make sense? *Archives of Trauma Research*, 1(3), 101–107.

Annamalai, M., Khairani, N. A., & Rahmat, M. H. (2015). *Agent-oriented simulation of emergency department re-triage based on allocated time to treatment*. Proceedings of the Conference on Biomedical Engineering and Sciences, Miri, Malaysia.

Exadaktylos, A. K., Evangelopoulos, D. S., Wullschlegler, M., Bürki, L., & Zimmermann, H. (2008). Strategic emergency department design: An approach to capacity planning in healthcare provision in overcrowded emergency rooms. *Journal of Trauma Management & Outcomes*, 2(1), 11.

Fomundam, S., & Herrmann, J. (2007). A survey of queuing theory applications in healthcare. *Mechanical Engineering*, 24, 1–22.

Green, L. V., Soares, J., Giglio, J. F., & Green, R. A. (2006). Using queuing theory to increase the effectiveness of emergency department provider staffing. *Academic Emergency Medicine*, 13(1), 61–68.

Groop, P. J., Reijonsaari, K. H., & Lillrank, P. M. (2011). Applying the Theory of Constraints to Health Technology Assessment. *International Journal On Advances in Life Sciences*, 2(3), 115–124.

Krajewski, L., Ritzman, M., & Malhotra, N. (2006). *Operations Management: Processes And Value Chains* (8th ed.). Prentice Hall.

Lewis, R., & Edwards, N. (2015). *Improving length of stay: what can hospitals do?* London: Nutfield Trust. Retrieved from <http://www.nuffieldtrust.org.uk/sites/files/nuffield/publication/improving-length-of-stay-for-web.pdf>

Lin, C. H., Kao, C. Y., & Huang, C. Y. (2015). Managing emergency department overcrowding via ambulance diversion: A discrete event simulation model. *Journal of the Formosan Medical Association*, 114(1), 64–71.

Maria, A. (1997). *Introduction to modelling and simulation*. Proceeding of the 29th Conference on Winter Simulation, Washington, DC, USA.

Martin, B. (2010). *Calculating utilization in a service company*. Boston: OpenAir. Retrieved from <http://www.openair.com/home/OpenAirWhitePaper-CalculatingUtilization.pdf>

McManus, M. L., Long, M. C., Cooper, A., & Litvak, E. (2004). Queuing theory accurately models the need for critical care resources. *Anesthesiology*, 100(5), 1271–1276.

Rahmat, M. H., Annamalai, M., Halim, S. A., & Rashidi, A. (2013). *Agent-based modelling and simulation of emergency department re-triage*. Proceedings of the IEEE Business Engineering and Industrial Applications Colloquium, Langkawi, Malaysia.

Simsit, Z. T., Gunay, N. S., & Vayvay, O. (2014). Theory of Constraints: A Literature Review. *Procedia - Social and Behavioral Sciences*, 150, 930–936.

Taboada, M., Cabrera, E., Iglesias, M. L., Epelde, F., & Luque, E. (2011). An agent-based decision support system for hospitals emergency departments. *Procedia - Computer Science*, 4, 1870–1879.

Venugopal, V., Otero, D. L., Otero, C. E., & Centeno, G. (2012). *A simulation model for evaluating resource policies in a major emergency department*. Proceedings of the IEEE Southeastcon, Conference, Orlando, USA.

Zeinali, F., Mahootchi, M., & Sepehri, M. M. (2015). Resource planning in the emergency departments: A simulation-based metamodelling approach. *Simulation Modelling Practice and Theory*, 53, 123–138.

Zeltyn, S., Lauterman, T., Schwartz, D., Moskovitch, K., Tzafir, S., Basis, F., & Shtub, A. (2011). Simulation-based models of emergency departments: *ACM Transactions on Modeling and Computer Simulation*, 21(4), 1–25.

Design and Evaluation of a Multilanguage Instant Messaging Application

Ahmed Nabeel Ahmed, Suwannit Chareen Chit, and Mohd. Hasbullah Omar

Universiti Utara Malaysia, Malaysia, cpu_cs1@yahoo.com; {chareen, mhomar}@uum.edu.my

ABSTRACT

Recent growth in mobile Internet has resulted in the emergence of instant messaging (IM) applications. These applications now allow users to communicate via text and voice messaging, as well as sending attachments to their intended recipients. While these applications now support multiple languages, they only allow users to communicate using the same language. A communication barrier and breakdowns occur when users do not speak the same language. This paper describes the design of Multilingual Instant Messaging Application (MIMA), and measure the level of acceptance of the application. Respondents agree that MIMA is both useful and easy to use, and this application is an essential tool to bridge the communication gap between speakers of different languages.

Keywords: Mobile Application, Machine Translation, Technology Acceptance.

I INTRODUCTION

The mobile Internet technology has paved ways for the emergence of various applications. One of the main applications is Instant Messaging (IM). IM applications such as WhatsApp ("WhatsApp," n.d.), WeChat ("WeChat Messenger," n.d.), Line ("Line Messenger," n.d.), Telegram ("Telegram Messenger," n.d.) and Viber ("Viber Messenger," n.d.) allow users to communicate via text messaging, voice and video calls as well as allowing users to append attachments to their intended recipients. These applications also support multiple languages, and they have now gained huge popularity among IM users.

These applications however, do not feature machine translation (MT) capabilities thus limiting its use to only users speaking the same language. This is a limiting factor which poses communication barriers if users do not speak the same language thus hindering the growth of IM applications. MT is therefore an essential feature for IM applications today.

In this paper, we design the Multilingual Instant Messaging Application (MIMA) which incorporates MT in its functionality. MIMA intends to allow users who do not speak the same language to communicate effectively. This is achieved by using of a real-time

MT function that is embedded in our application. We also conducted a survey to gauge the usefulness and ease of use of MIMA. The results of this survey indicate that MIMA is both useful and very easy to use.

In this paper, we relate our experience in developing the MIMA. This paper is organized as follows: The following section (Section II) reviews existing IM applications. We also review some existing work on MT. In Section III and Section IV, the design and development of MIMA is presented. We describe the survey we conduct in Section V. Section VI discusses our findings and we conclude this paper in Section VII.

II BACKGROUND

IM applications have gained tremendous popularity driven by the impressive growth of mobile Internet technology. However, most of these applications only allow users of the same language to communicate, resulting in a communication barrier between users who speak different languages. To break the language barrier, MT is therefore a favourable feature in most IM applications today. In this section, we review some of these IM applications as well as some related work to MT. We also briefly discuss the Technology Acceptance Model (TAM) that we used to measure the acceptance level of MIMA.

A. Instant Messaging (IM) Applications

3rd Generation (3G) network made its debut in 2001 and that marks the beginning of mobile Internet technologies. Ever since then, 3G networks have paved ways for the emergence of various applications including instant messaging (IM). These applications can be operated on a desktop computer, notebook, tablet and/or smartphone. Generally, these applications allow text messaging (inclusive the use of fancy *emojis* and icons), voice and video calls, and delivery of attachments. Multiple languages are supported by these applications. IM applications provide users a ubiquitous and cheaper means of communication as they normally require Internet connection and are free for download and use. As a result, a number of IM applications exist and they are highly popular and these applications have changed how we communicate and work. WhatsApp, WeChat, LINE, Telegram and Viber are instances of IM applications widely used globally and we have

performed a comparative analysis of these applications. The scope of comparison includes platforms, personalization, communication feature,

file transfer, cost, language and others. The comparative analysis is presented in Table 1.

Table 1. Comparison of Existing IM Applications

Application	WhatsApp	WeChat	Line	Telegram	Viber
Platform	iOS, Android, BlackBerry, Windows, Symbian	iOS, Android, BlackBerry, Windows, Symbian	iOS, Android, BlackBerry, Windows	iOS, Android, BlackBerry, Windows	iOS, Android, BlackBerry, Windows
Personalization	✓	✓	✓	✓	✓
Communication					
• Text	✓	✓	✓	✓	✓
• Voice Call	✓	✓	✓	✓	✓
• Video Call	X	✓	✓	X	✓
• Group	Maximum 256 members	Maximum 500 members	Maximum 200 members	Maximum 5000 members	Maximum 200 members
File Transfer	✓	✓	✓	✓	✓
Cost	Free	Free	Free	Free	Free
Games	X	✓	✓	X	X
Others					
• Requires Registration	✓	✓	✓	✓	✓
• Contacts	Automatically updated from device contact	WeChat ID & Automatically updated from device contact	Line ID & QR Code	Automatically updated from device contact	Automatically updated from device contact
• QR Code Scanning	X	✓	✓	X	X
• Multilingual support	✓	✓	✓	✓	✓
• Real-time Machine Translation	X	X	X	X	X

As presented in Table 1, the features in IM application vary. It can particularly be noted that in all of these applications, real-time MT is absent. The absence of the MT feature provides a gap for us to further improve IM applications.

B. Machine Translation (MT)

Machine Translation (MT) is a widely researched area that began two decades ago (Koehn & Philipp, 2010) and is still gaining a lot of attention particularly in its accuracy in translating texts in specific domains. In law for example, MT tools are found to be inefficient to translate legal documents (Yates, 2006). However, several studies conducted have revealed that efficiency of MT is strongly linked to users' expectation. In a research on the comprehensibility of Spanish to English translations made by SYSTRAN the respondents' feedback showed that 10 out of 12 texts could be understood, which suggests 83% accuracy (Aiken, Vanjani, & Wong, 2006). The authors therefore linked accuracy to understandability.

In another study, researchers used Polyglot II study the accuracy of Google Translate. The research was conducted on 41 languages and their findings suggest that overall accuracy was 86% for all languages. An interesting observation the researchers was machine

translation worked better with some languages such as Italian, Serbian and Russian, than with some others like Filipino, Japanese and Hindi (Aiken & Ghosh, 2009).

Calefato, Lanubile and Minervini (2010) used two real-time MT services: Google Translate and Apertium to study the efficiency and accuracy of MT when stakeholders discuss software requirements. In their study, a 4-point Likert scale as a scoring scheme is used, anchored with the following values: 4 being "completely inadequate," and 1 being "completely adequate." They found that Google Translate produces significantly more adequate translations from English to Italian than Apertium and that both services can be used in text-based chat without disrupting real-time interaction (Calefato, Lanubile, & Minervini, 2010). Aiken and Balan (2011) also focused on the accuracy of Google Translate by reviewing several studies comparing Google Translate with other MT systems. They concluded that although accuracy rates vary across languages, "translations between European languages are usually good" (Aiken & Balan, 2011).

Another study measured the level of clarity and accuracy in real-time chat messages. These messages are translated immediately by translation bots

embedded in GoogleTalk. This study was conducted between speakers who have Russian and English native language. The overall evaluation for this study shows that 83.57% of the translations were intelligible and 75.20% were accurate (Sahin & Duman, 2013).

C. Interlingual Machine Translation (IMT)

Interlingual Machine Translation (IMT) is an example of the rule-based machine-interpretation procedures. In IMT, the text of the source language is converted into an interlingual representation, known as "language neutral" which is independent of any language. The interlingual then generates the target language, as shown in Figure 1. One of the most vital benefits of this approach is that the interlingua can become more and more valuable if there is increasing in the number of target languages (Monem, Shaalan, Rafea and Baraka, 2008). The English language has been selected as the interlingual in this study.

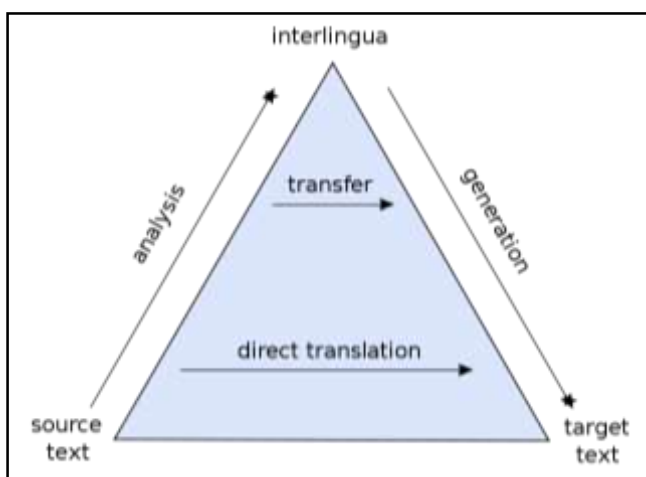

Figure 1. Interlingual Machine Translation (IMT)

D. Google API translator

Google Translate is a free multi-lingual measurable machine interpretation administration gave by Google to decipher constant recordings, addresses, pictures, and messages from one dialect to the next. It offers a mobile interface for Android and iOS, a web interface, and an API translator which developers may use for developing browser extensions, applications and other type of software. Up to this time, i.e., February 2016, Google Translate underpins 103 dialects at numerous levels and serves more than 200 million individuals day by day (Groves and Mundt, 2015; Shankland, 2013).

E. Technology Acceptance Model (TAM)

Technology Acceptance Model (TAM) has been widely used to measure user's acceptance and uptake of technology (Venkatesh, Morris, Davis, & Davis, 2003) Generally, the TAM measures the acceptance of technology based on a 2-dimensional perspective, namely usefulness (Perception of Usefulness - POU) and ease-of-use (Perception of Ease Of Use – POEU).

TAM also suggests that there exist several factors which influence a user's decision to uptake and use a specific technology.

III MIMA DESIGN

The MIMA prototype is developed using the Java programming language on the Eclipse Integrated Development Environment (IDE). MIMA is presently developed to operate on an Android device featuring the basic functionalities as per Table 1, incorporating the MT feature. MIMA database uses the SQLite tools.

The real-time MT feature is accomplished by embedding in the text messaging functionality the Google Translate Application Programming Interface (API) as shown in Figure 2.

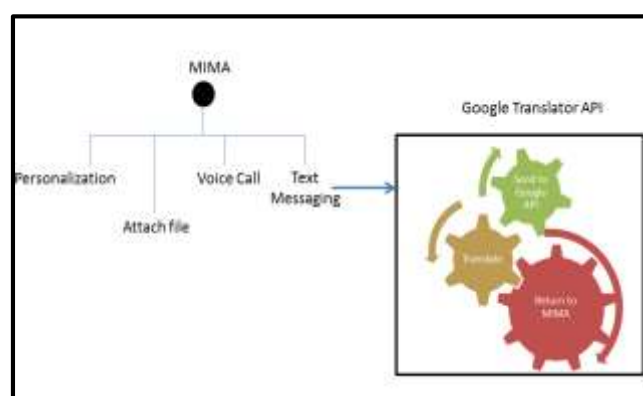

Figure 2. MIMA Concept

In the first place, the design must be completed; this incorporates the outlining assignments to guarantee that the capacities were legitimately organized under the class of antiquities, for example, the use case diagram, active diagram, sequence diagram and state diagram. Keeping in mind the end goal to outline the model, the UML (Unified Modeling Language), which is a graphical dialect for envisioning, determining, fabricating and archiving the ancient rarities of programming concentrated frameworks (Booch, 2005), was utilized as a part of this study. Other than that, the configuration rule that make the application simple to utilize were additionally thought about through the investigation of existing application.

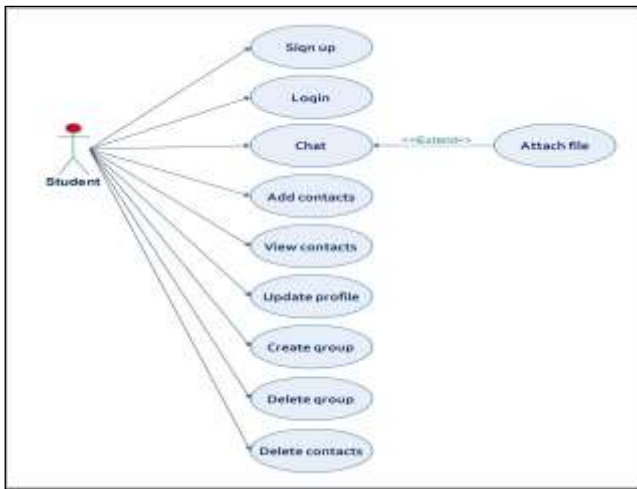

Figure 3. MIMA Use Case Diagram

Figure 3 show MIMA Use Case diagram. The Use Case diagram is one of the modeling methods which describe what does a certain application from an external observer standpoint. The main goal of using use case diagram is to understand app functions and what it does; an actor is involved in doing app functions (AbdulWahid, 2015; Banire, Jomhari, & Ahmad, 2015).

IV MIMA DEVELOPMENT

In general, there are numerous principles for implementing and design of useful and successful mobile application. In order to design a mobile chat application that helps students in breaking the language barrier, the design principles lead to produce a creative and effective application, while these principles have been previously conducted and analyzed in details. This study utilized the RAD strategy (Rapid Application Development) to build up the application (Anderson, Patel, Preedy, & Martin, 2014).

In order to develop the prototype for this study, the JAVA development tool (JDK) has been used under Android platform, and for the database it was used SQLite tools. Additionally, Eclipse (IDE) tool is used to develop the prototype (Murphy, Kersten and Findlater, 2006). Figure 4 shows MIMA chatting interfaces.



Figure 4. MIMA Chatting Interfaces

It was clearly seen, the first user selected Arabic language, and he can send and receive messages in Arabic. On the other hand, the second user selected Malay language, and he can send and receive messages in Malay language.

V EVALUATION

This section discusses the procedure of acceptance test that was carried out to illustrate the usability of MIMA.

A. Acceptance Test

The acceptance test is conducted to ensure that users feel the MIMA is useful and is easy to use. In this study, a survey was conducted involving 30 Universiti Utara Malaysia (UUM) students from various nationalities to collect their perceptions on the ease of use and usefulness of MIMA. They were asked to use the MIMA application, and answer the questionnaires which were handed to them.

The questionnaire used what adapted from previous acceptance tests. Users were asked to rate the MIMA using a Likert scale from 1 to 7, with 1 being "Strongly Disagree" and 7 being "Strongly Agree". The items in the questionnaire are as shown in Table 2.

Table 2. Questionnaire Items

Question	Item
U.Q1	MIMA allows me to communicate effectively.
U.Q2	Using MIMA could save my time.
U.Q3	Using MIMA could save my efforts.
U.Q4	MIMA makes it easier for me to communicate.
U.Q5	MIMA would facilitate my communication with people who speak different languages.
U.Q6	I would find MIMA useful in my communications.
E.Q7	MIMA is easy to use.
E.Q8	MIMA is flexible to use.
E.Q9	MIMA is simple to use.
E.Q10	It is user friendly.
E.Q11	Learning to use MIMA is easy.
E.Q12	I learned to use MIMA quickly.
E.Q13	I can use MIMA without written instructions.
E.Q14	It would be easy for me to become skillful at using

	MIMA.
E.Q15	Interaction with MIMA is flexible.
E.Q16	My interaction with MIMA is clear.
E.Q17	I can accomplish what I want to do with MIMA easily.
E.Q18	Overall, I am satisfied with this application.

VI RESULTS & FINDINGS

In the survey conducted, the following result is gathered and the frequency table is tabulated in Table 3.

Table 3. Frequency Table

Item (n = 30)	Strongly Disagree (%)	Disagree (%)	Slightly Disagree (%)	Neutral (%)	Slightly agree (%)	Agree (%)	Strongly Agree (%)	Percentage (%)
UQ1	0	0	0	0	18.7	50.0	31.3	100
UQ2	0	0	0	6.3	43.7	37.5	12.5	100
UQ3	0	0	0	9.4	31.2	50.0	9.4	100
UQ4	0	0	0	0	21.9	46.9	31.2	100
UQ5	0	0	0	9.4	15.6	43.8	31.2	100
UQ6	0	0	0	0	18.7	68.8	12.5	100
EQ7	0	0	0	3.1	25.0	43.8	28.1	100
EQ8	0	0	0	9.4	15.6	53.1	21.9	100
EQ9	0	0	0	6.3	34.3	53.1	6.3	100
EQ10	0	0	0	3.1	28.1	28.1	40.7	100
EQ11	0	0	0	12.5	18.7	43.8	25.0	100
EQ12	0	0	0	9.4	40.6	31.3	18.7	100
EQ13	0	0	0	6.3	37.5	43.8	12.4	100
EQ14	0	0	0	9.4	37.5	28.1	25.0	100
EQ15	0	0	0	9.4	18.7	50.0	21.9	100
EQ16	0	0	0	3.1	15.6	56.3	25.0	100
EQ17	0	0	0	9.4	37.5	50.0	3.1	100
EQ18	0	0	0	0	28.1	50.0	21.9	100

More than 50% of the respondents agree that MIMA allows them to communicate effectively (UQ1), and approximately 37.5% agree that MIMA saves time (UQ2) when the users try to communicate with another user who speaks a different language. The MIMA also requires minimal effort (UQ3) as reported by 60% of the respondents. In terms of usefulness (UQ6), 81% of the respondents agree that MIMA is useful while 78% responded that MIMA makes communication easier (UQ4) and 75% responded that MIMA facilitates better communication (UQ5).

In terms of ease of use, 78% agree that MIMA is easy to use (EQ7). Most of the respondents (78%) also find that the application is user friendly (EQ10), where 59% believe it is flexible to use (EQ8) and 69% agree that the application is simple (EQ9).

The respondents also agree that learning to use MIMA is easy. Overall, 72% of the total respondents are satisfied with the application. We feel there is room to further improve MIMA particularly in terms of making MIMA easier to learn.

The descriptive statistics of our survey are presented in Table 4 below.

Table 4. Descriptive Statistics

Question	Item	Mean	Standard Deviation
U.Q1	MIMA allows me to communicate effectively.	6.13	.707
U.Q2	Using MIMA could save my time.	5.56	.801
U.Q3	Using MIMA could save my efforts.	5.59	.798
U.Q4	MIMA makes it easier for me to communicate.	6.09	.734
U.Q5	MIMA would facilitate my communication with people who speak different languages.	5.97	.933
U.Q6	I would find MIMA useful in my communications.	5.94	.564
E.Q7	MIMA is easy to use.	5.97	.822
E.Q8	MIMA is flexible to use.	5.88	.871
E.Q9	MIMA is simple to use.	5.59	.712
E.Q10	It is user friendly.	6.06	.914
E.Q11	Learning to use MIMA is easy.	5.81	.965
E.Q12	I learned to use MIMA quickly.	5.59	.911
E.Q13	I can use MIMA without written instructions.	5.63	.793
E.Q14	It would be easy for me to become skillful at using MIMA.	5.69	.965
E.Q15	Interaction with MIMA is flexible.	5.84	.884
E.Q16	My interaction with MIMA is clear.	6.03	.740
E.Q17	I can accomplish what I want to do with MIMA easily.	5.47	.718
E.Q18	Overall, I am satisfied with this application.	5.94	.716

The results in Table 4 show that all questions have high mean score, which is approximately 6. Besides, the standard deviations are small, which is less than 1. It can therefore be deduced that all statements regarding the MIMA in the questionnaire are agreed by the subjects with very small bias or influence of other factors.

A reliability test was also conducted on the questionnaire items and the results are presented in Table 5 below.

Table 5. Reliability test

Cronbach's Alpha	Cronbach's Alpha Based on Standardized Items	N of Items
.687	.680	18

VII CONCLUSION

The advancement of the computers and its technology have paved ways for the emergence of instant messaging applications and Machine Translation (MT) tools. These tools allow real-time text translation with reasonable precision and accuracy. In this study, a Multilanguage Instant Messaging Application (MIMA) is presented. The MIMA is an instant messaging application which incorporates the MT tool, as well as other features which appeal to the demands of mobile users today. The application is developed using Java, and runs on most Android platforms. A usability and usefulness test was carried out. In this survey, 81% agree that the MIMA is useful, and is more than 75% agree that is it easy to use. Overall, 72% of the users are satisfied with MIMA.

REFERENCES

- AbdulWahid, H. S. (2015). Requirements for redesigning the interface of Iraqi e-government portal. Universiti Utara Malaysia.
- Aiken, M., & Balan, S. (2011). An analysis of Google Translate accuracy. *Translation Journal*, 2(16).
- Aiken, M., & Ghosh, K. (2009). Automatic translation in multilingual business meetings. *Industrial Management & Data Systems*, 7(109), 916–925.
- Aiken, M., Vanjani, M. B., & Wong, Z. (2006). Measuring the accuracy of Spanish-to-English translations. *Issues in Information Systems*, 7(2), 125 – 128.
- Anderson, J. S., Patel, V. B., Preedy, V. R., & Martin, C. R. (2014). *Comprehensive guide to autism*. New York: Springer.
- Banire, B., Jomhari, N., & Ahmad, R. (2015). Visual Hybrid Development Learning System (VHDL) Framework for Children with Autism. *Journal of Autism and Developmental Disorders*, 45(10), 3069–3084.
- Booch, G. (2005). *The unified modeling language user guide*. Pearson Education India.
- Celefato, F., Lanubile, F., & Minervini, P. (2010). Can Real-Time Machine Translation Overcome Language Barriers in Distributed Requirements Engineering? In *5th IEEE International Conference on Global Software Engineering (ICGSE)* (pp. 257 – 264). IEEE.
- Groves, M., & Mundt, K. (2015). Friend or foe? Google Translate in language for academic purposes. *English for Specific Purposes*, 37, 112–121.
- Koehn, & Philipp. (2010). *Statistical Machine Translation*. Cambridge: Cambridge University Press.
- Line Messenger. (n.d.).
- Monem, A. A., Shaalan, K., Rafea, A., & Baraka, H. (2008). Generating Arabic text in multilingual speech-to-speech machine translation framework. *Machine Translation*, 22(4), 205–258.
- Murphy, G. C., Kersten, M., & Findlater, L. (2006). How are Java software developers using the Eclipse IDE? *Software, IEEE*, 23(4), 76–83.
- Sahin, M., & Duman, D. (2013). Multilingual Chat through Machine Translation: A Case of English-Russian. *Translators' Journal*, 2(58), 397 – 410.
- Shankland, S. (2013). Google Translate now serves 200 million people daily. *Cnet*.
- Telegram Messenger. (n.d.).
- Venkatesh, V., Morris, M. G., Davis, G. B., & Davis, F. D. (2003). User acceptance of information technology: Toward a unified view. *MIS Quarterly*, 425–478.
- Viber Messenger. (n.d.).
- WeChat Messenger. (n.d.).
- WhatsApp. (n.d.).
- Yates, S. (2006). Scaling the tower of Babel Fish: an analysis of the machine translation of legal information. *Law Library Journal*, 481.

iMoS: Intelligence Monitoring System of HIV Carriers in Thailand

Ratchasak Somyanonthanakul¹, and Thanachai Ludkrood²

¹Rangsit University, Thailand, ratchasak.s@rsu.ac.th

²The Thai Red Cross Society AIDS Research Centre, thnanchai_30@hotmail.com

ABSTRACT

The World Health Organization (WHO) launched universal strategy in HIV prevention in 2012 called “Test & treat HIV prevention”. (iMoS) Intelligence Monitoring System is developed a prototype in order to be a monitoring platform to support the medical treatment of HIV carriers by integrating information technology approaches in fields of database, communication, and mobile application. iMoS consists of three main modules: 1) The clinical module; 2) The laboratory module; and 3) The monitoring module that transfer data with each other on computer network. The Clinical module is a front office to collect a client data and medical record form registration process. The risk assessment data is fed into database by consulting process. The Laboratory module is scientific machine section to perform testing Anti-body HIV and CD4 testing with international standard to complete medical data. Morning module is the front-end application to contract with HIV carriers using wearable mobile device under privacy policy. It is important to take standardize monitoring HIV carriers by using information technology platform. The iMoS is intended to implement all HIV carriers in order to reduce new HIV infection and get into prompt medical treatment.

Keywords: HIV, Monitoring System, Thailand

I INTRODUCTION

Human immunodeficiency virus (HIV) is a global healthcare problem. Most than 7,000 people are newly with HIV infected every day. No country has escaped the devastation of this truly global epidemic (UNAIDS, 2011). Thailand is developing country which in public health policy has been effective in preventing the transmission of HIV on national scale (UNAIDS, 2014b). Thai Government is funded to support prevention program have saved millions of lives, reducing the number of new HIV carriers from 143,000 in 1991 to 9,700 in 2011. There are 490,000 people in Thailand are HIV carriers, and 23,000 people died from AIDS-illnesses (UNAIDS, 2014a). The first case of AIDS in Thailand occurred in 1984 (Phanuphak, 1985). The Thai Red Cross AIDS Research Centre (TRC-ARC) officially began operating in December 1989. TRC-ARC founded the Anonymous clinic provide medical services such are

to blood checking, advising on diseases transmitted through blood and sexual intercourse like AIDS, syphilis and hepatitis B (Phanuphak, 2014a).

The ‘Test & treat; New Strategy in HIV Prevention’ project conducts by The Ministry of Public Health’s Disease Control Department and TRC-ARC launched since November 2012. The project conducts in homosexual and transgender population and pilot provinces: Bangkok, Lampang, and Ubon Ratchathani. The project is expanded into all newly HIV positives and risk groups such as injecting drug user, men who have sex with men (MSM), migrant workers, and sex workers (Phanuphak, 2014b). A strategy of universal HIV testing for person aged > 15 years and immediate administration of antiretroviral therapy for those found to be positive. In South Africa, the researcher use mathematical model to predict the number of new HIV infection. The result show rapid reduction to less than 1% within 50 years (Granich et. Al, 2009). All Thai people eligible for treatment receiving follow the World Health Organization (WHO) guidelines of initiating antiretroviral drugs (ARVs) at CD4 all levels.

Viral load refers to the amount of HIV in the blood. If the viral load is high, T-helper cells tend to be destroyed more quickly. Therefore, the aim of antiretroviral treatment is to keep the viral load as low as possible. Monitoring system is recommended to be based on viral load, rather than CD4 count, because it provides greater accuracy of test results. The current WHO treatment guidelines recommend that a viral load test is carried out at 6 months after treatment begins, at 12 months, and then every year. If the treatment is working effectively the viral load will drop to an undetectable level below 50 copies/ml. Ideally this will happen within 24 weeks of starting treatment, but for some it can take 3 to 6 months. On the other hand, some people never reach undetectable in which case alternative regimens can be started if necessary. (UNAIDS, 2012).

Tracking system is importance to keep tracking of HIV carrier progress and medi-cal treatment status. TRC-ARC updates status of all clients. HIV carriers can gain benefit from tracking system since they can get useful information for eligible of medical treatment. Generally, tracking methods include hardcopy letter, telephone, short message service, and door-to-door. (Wu et. al., 2012).

In this paper, we design monitoring system based on ResearchKit under TRC-ARC procedure on service operation and laboratory result operate under international standard. The system could gather client information, perform medical testing, and provide HIV carriers report to tracking process. All service processes operate under protecting the privacy of client. The hold of the paper is organized as follows. Section 2 introduces the framework of the monitoring system. Section 3 describes Monitoring system. Section 4 experimental method, and Section 5 shown researchkit framework and section 6 conclusion our work and shows future develops.

II MONITORING FRAMEWORK

A. Conceptual Framework

Fig. 1 shows the structure of Intelligence Monitoring system (iMoS). The iMoS consists of clinical module, laboratory module, monitoring module, and front-end devices.

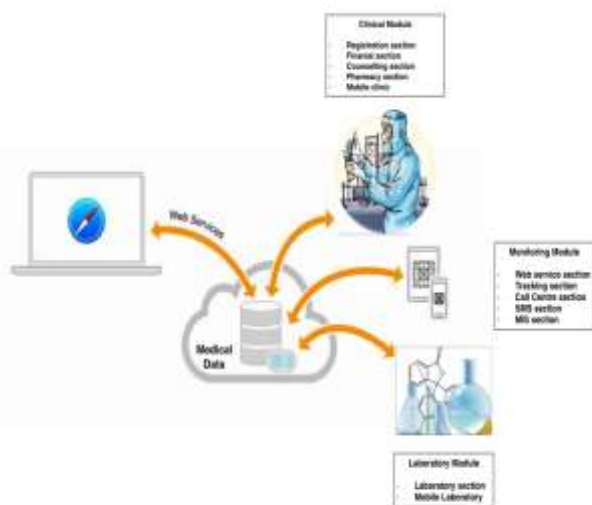

Figure 1. Intelligence Monitoring System.

Clinical module is front office that mainly responsible for register all clients. HID (Hospital Identification) is assigned to new clients. Clients fill personal information to application form and they can concealable personal information. Clients consulted by professional consular assessed risk information, consulted psychological process and assigned laboratory testing order to client.

Laboratory module conducts HIV testing and CD4 count (Cluster of Differentiation 4) (UNAIDS, 2013) by healthcare professional who takes a blood sample from the arm or finger. In Thailand, TRC-ARC combines three methods of tests that are used to find out whether HIV carriers; HIV antibody 4th generation test, NAT (Nucleic Acid Amplification Testing) and RNA

Monitoring module responsible for gathering medical data and update HIV carries status. Medical data include personal information, HIV test date, available time, affiliation, phone number. HIV carrier status consists of HIV testing and CD4 results start date of medical treatment, hospital name and monitoring records.

Mobile network is the medium that can carry multimedia and information such as voice, Short Messaging Service (SMS), e-mail, world wild web, social media, VDO conference contract between the monitoring system and the HIV carriers. Every people can access or push information from their wearable mobile devices. However, the HIV carrier can use the monitoring system only after their permission.

Wearable mobile devices are end terminals. These devices can be smart-watch, smartphone, computer-tablet and laptop computer. The wearable mobile devices are operated under several kind of platforms are iOS, android, windows phone, blackberry etc. Mobile application is important software that can serve user to access huge information.

To summarize, the monitoring system retrieve information from the clinical unit and HIV testing and CD4 results form the laboratory unit. The monitoring system provides medical services for HIV carrier though mobile internet and mobile devices.

B. System Flowchart

Professional counselor initiate counseling and testing model (PICT) to identify HIV risk levels. (Sibanda, 2009). The healthcare professional takes a blood sample from the arm or finger for HIV anti-body test. About 1 hour after the blood-test, counselor will again call client to give HIV the result for HIV test. (TRC-ARC, 2013a). If result of HIV status is positive, counselor has to con-firm the result and sign acceptance monitoring form. HIV carriers are contracted after HIV testing two weeks. Monitoring method depends on their acceptance such as phone call, SMS, e-mail. Medical treatment is the most importance data that have to record in to the system. Hospital name, medical treatment period, CD4 result will be recorded and prepare for the next monitoring.

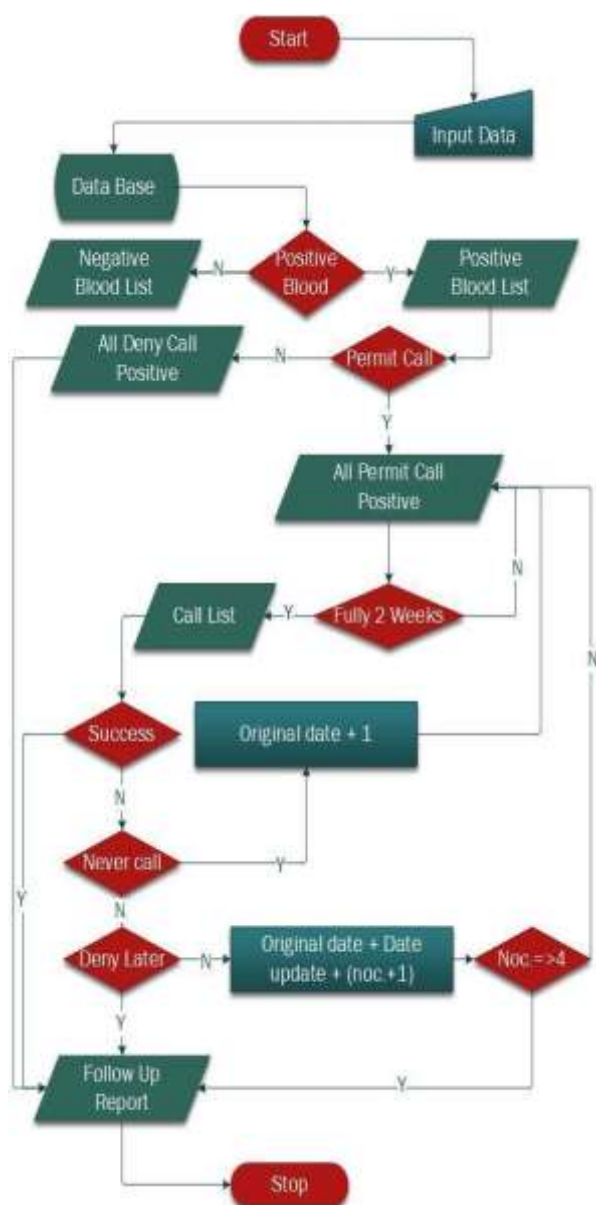

Figure 2. System Flowchart.

III INTELLIGENCE MONITORING SYSTEM

The Clinical Module. Anonymous Clinic service client under protect and privacy policy. There are five section follow. Registration section support clients data to provide personal information. Financial section manage cash system and billing. Counseling give pre-test and posttest result to client. Pharmacy section distribute medical supply to clients. Mobile clinic provide service to target area.

The Laboratory Module. Professional Medical technical take blood sample. Blood or specimen is collected seven milliliters of blood in an EDTA-treated tube (to prevent it from clotting), and have the tube sent to blood test machine. All process spends one hour to report HIV test. There are two kid of

laboratory follow. Laboratory Section get specimen to test Anti-HIV, CD-4 and other specific result. Mobile Laboratory operate with mobile clinic.

Monitoring module. The monitoring system is the module is created to support “Test and treat prevention program”. All HIV carriers have to monitoring under WHO treatment guidelines. Medical treatment, viral load and CD4 count provides greater accuracy of test results within 24 weeks. Monitoring modules consist of web service section provide platform service. Call Centre section support client and provide service information. Management Information System section process properly information to all level employee. Monitoring section maintain infrastructure for monitoring system.

IV EXPERIMENT METHOD

Design of System. iMoS consists of medical data center that store all information of clients and other attached facilities. The system is divided into three modules, which are the clinical module, the laboratory module, and monitoring module. The clinical module contains basic medical data form client and supports daily medical services. Respond time is the key main factor to design physical system. The laboratory module provides medical results under international standard. Reliability is the pivotal in this module. Medical devices of Third party have to compatible with main system. The monitoring module contracts to all HIV carriers with variety kind of methods. Accessibility is the importance to tracking all clients.

Design of Sample. We collected data form the clinical modules since 2010 -2015. Table 1 shows demography of each result will be analyzed in order to use properly method to monitoring.

Table 1. Demography of Client.

Item	Detail	Numeric
Gender	Male	80 %
	Female	20 %
Age	Average	29.8 years
	SD	13.4
Visiting	First Time	13.65%
	Monitoring	78.2%
HIV Status	Positive	93%
	Negative	7%

*Number of patient = 174,117

V RESEARCHKIT FRAMEWORK

The ResearchKit framework is an open source software framework to create research applications on iOS. This framework takes advantage of sensors and capabilities of iOS device to track movement, take

measurements, and record data. Users can perform activities and generate data from anywhere. There are three customizable modules that address some of the most common elements of research: surveys, consent, and active tasks.

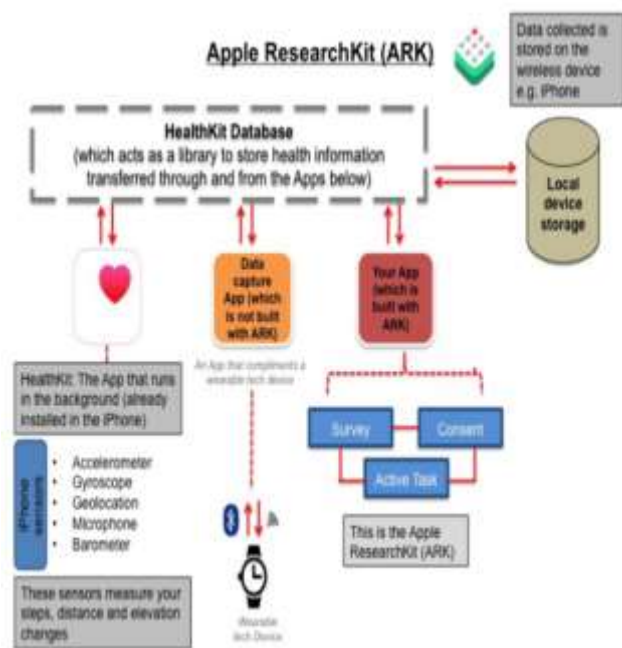

Figure 2. ResearchKit Framework.

The survey module predefined user interface lets you quickly build surveys simply by specifying the questions and types of answers. The survey module is already localized, so all you need to do is localize your questions.

The consent module in research studies are sensitive information as part of their enrollment and involvement in the study. It is critical to clarify exactly what information will be collected from users and who will have access to their information.

The activity task module is provided by responses to survey questions or the data collection capabilities of APIs on iOS. Active tasks invite users to perform activities under partially controlled conditions using iOS device sensors to actively collect data following.

VI CONCLUSION

The number of HIV carriers and their monitoring data increase rapidly. Traditional monitoring methods are not effective enough. To fill the huge discrepancy, we proposed Test and Treat monitoring system. The system consists of Clinical, Laboratory, and Monitoring module. This Monitoring system is developed using ResearchKit on iOS device and help the TRC-ARC to know more about HIV carriers' states of medical data. At the same time, the doctor and researcher could track in a convenient and

efficient way. The future improvements of this work can be done in several ways. First, we develop with wearable devices. Second, the HIV carriers have to have a check-up and then fill in the mobile application by hand at present. We can use sensors device to monitor the HIV carriers's condition in real time. Third, more security measures should be applied to protect privacy policy and other unauthorized access. Successful completion of this research will hopefully empower form TRC-ART to support HIV carriers. Future work aims at developing web application for call center section and a mobile application that would provide tracking data in the same manner.

ACKNOWLEDGMENT

This research project would not have been possible without the support of many people. I wish to express my gratitude to Prof. Emeritus Dr. Praphan Phanuphak who is abundantly helpful and offered invaluable assistance, support and guidance. Deepest gratitude is also due to the health care workers at The Thai Red Cross AIDS Research Centre and Rangsit University students in Service Science program.

REFERENCES

- Granich, R., Gilks, C., Dye, C., Cock, K., & Williams, B. (2009). Universal voluntary HIV testing with immediate antiretroviral therapy as a strategy for elimination of HIV transmission: a mathematical model. *Lancet*, 373, 48-57.
- Phanuphak, P., Lochareonkul, C., Panmuong, W. & Wilde H. (1985). A report of three cases of AIDS in Thailand. *Asian Pac J Allergy Immunol*, 3, 195-199.
- Phanuphak, P. (2014a). *History*. Retrieved from The Thai Red Cross AIDS Research Centre: http://www.trcsrc.org/Homepage/?page_id=1005
- Phanuphak, P. (2014b). *Prevention Research*. Retrieved from website. http://www.trcsrc.org/Homepage/?page_id=1143
- Sibanda, W. & Pretorius, P. (2014) Development and Validation of an HIV risk scorecard model. *Proceedings of IEEE/ACM International Conference on Advance in Social Networks Analysis and Mining*, 916-922.
- UNAIDS. (2011). Uniting for universal access: towards zero new HIV infections, zero discrimination and zero AIDS-related deaths, http://www.unaids.org/sites/default/files/en/media/unaids/contentassets/documents/document/2011/20110331_SG_report_en.pdf
- UNAIDS. (2012). Starting, Monitoring & Switching HIV Treatment, Retrieved from <http://www.avert.org/starting-monitoring-switching-hiv-treatment.html>
- TRC-ARC. (2013a). 3 Simple Steps for HIV Testing, Retrieved from <http://www.adamslove.org/en-d.php?id=69>
- UNAIDS. (2013b). CD4 count, Retrieved from <https://www.aids.gov/hiv-aids-basics/just-diagnosed-with-hiv-aids/understand-your-test-results/cd4-count/>
- UNAIDS. (2014a). HIV&AIDS in Thailand. Retrieved from website. <http://www.avert.org/hiv-aids-thailand.html>.
- UNAIDS. (2014b). Thailand Ending AIDS, Retrieved from http://www.unaids.org/sites/default/files/en/dataanalysis/knowyourresponse/countryprogressreports/2014countries/THA_narrative_report_2014.pdf
- Wu, Y., Shoa, J., Fu, W. & Zhou, T. (2013). Information Push Based Discharged Patient Follow-up System. *Ubi-HealthTech*, 1-5.

Pragmatic Design of Methodology in Process-Based Knowledge Integration

Yew Kwang Hooi, Mohd Fadzil B Hassan, Anouar Abrik, and Azmi M. Shariff

Universiti Teknologi Petronas, Malaysia,

{yewkwanghooi; anouarabrik}@gmail.com, {mfadzil_hassan; azmish}@petronas.com.my

ABSTRACT

This paper proposes a methodology to design a pragmatic ontology. Pragmatism can maximize the interaction between rules and ontology. A formal model provides the template for pattern identification of symbols and rules for manipulation by a logic machine. The ongoing research proposes pragmatics in knowledge engineering. However, current methodology does little to emphasize a truly pragmatic design in an ontology pattern. A critical analysis of the approach against existing methodologies has shown lack of research in this important area of ontology design.

Keywords: Knowledge-based system, ontology engineering, model-driven system.

I INTRODUCTION

Knowledge is power but only if it can be seen. In enterprises, knowledge is hidden in its trove of information such as relational database, XML data, unstructured and semi-structured documents. To be aware of this "obscured" knowledge is a difficult task and many semantic and big data researches have attempted to address this issue.

Knowledge integration is a challenging issue in an enterprise knowledge management. Integration of knowledge is a cognitive activity based on logic and meta-knowledge. Integration requires retrieval and linking. A conventional retrieval is difficult because the search itself must furnish information on the relationship between searched resources. A search engine is unaware of the implicit structure and relationship between linked concepts within the domain of the search. A knowledge model helps with the search by providing a platform to guide the discovery.

A knowledge model is simply logical knowledge and like any other logical knowledge, it does not map well to computer architecture, unlike procedural knowledge or factual knowledge. Thus, logical knowledge is encoded in a formal knowledge model such as ontology as an alternative to source code. The capacity of ontology to support dynamic changes makes it favorable for organizations to address change in management.

II ONTOLOGY AS A FORMAL MODEL

Ontology is a formal, explicit, shared conceptualization for knowledge sharing (Gruber, 1993; Neches et al., 1991; Uschold & Gruninger, 1996; Van Heijst, 1997). Ontology is a sample of domain knowledge and therefore only represents a subset, as shown in Figure 1. The ontology may also overlap with problem-solving knowledge, which is usually in the form of code. Other knowledge that is involved in problem solving is knowledge of data mining and knowledge of the data sets.

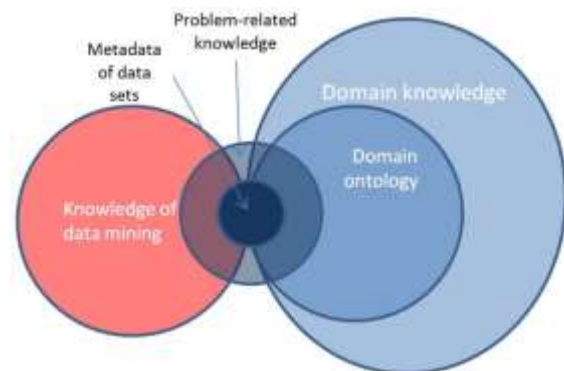

Figure 1. Types of knowledge models (Kuo, Lonie, Sonenberg, & Paizis, 2007)

The structure of ontology is given by $O = (S, A)$ where S is signature that describes the vocabulary and A , the axiom interpretation of vocabulary in the domain of discourse (Kalfoglou & Schorlemmer, 2003).

Ontology is used to provide the semantics of knowledge integration (Basil Eil, 2011) (Gonçalo Antunes, 2014) (Benaroch, 2002; Wache et al., 2001). The semantics provide the details that allow inference of meaning through heuristics rules using relational objects as a reference. The mechanism of integration is through using ontology as a knowledge framework for anchoring and linking instances of information specified by the properties of objects.

Ontology has the potential to be used by intelligent applications for its more powerful reasoning (Noy & McGuinness, 2001) and interoperability (Calvanese et al., 2007) capabilities.

III PROBLEM AND OBJECTIVE

Developing an oversized ontology may be counterproductive, i.e. large but not necessarily well utilized. Knowledge models have received criticism

for the difficulty to determine their scope. Various works state the bottleneck of the work is the lack of expressiveness of the knowledge model to deliver pragmatic results in real applications. To keep only useful concepts, a methodology should consider focusing on the pragmatic concepts by referring to the "verb" elements from business processes and policies.

There is a lack of methodologies that emphasize pragmatic ontology design. This article critically analyzes the advantage of a pragmatic structure in knowledge models and proposes a methodology for such.

There is also limited definition of pragmatic in the context of knowledge management at organizational and technical views.

This paper attempts to define pragmatics from a system development point of view. The definition is used to identify constraints and criteria for the methodology that we claim having potential to bring out a pragmatic design.

The main constituents of a methodology are people, product and process. The focus of this paper is on the process and the corresponding tools of the methodology (Dehghani & Ramsin, 2015). The people and product constituent will be explained incidentally.

IV PRAGMATIC AS THE WAY FORWARD

A. Definition of Pragmatic

The notion of pragmatics is commonly understood as a model that provides shared understanding on the intention and actual use of exchanged content in a given context (Camlon H. Asuncion). Pragmatic refers to actionable knowledge and is basically just the ontology necessary for process work (Thompson, 2005) (Anthony Debons, 2000). A simpler definition is "just that ontology necessary for process work" (Thompson 2005).

Interest in pragmatic:

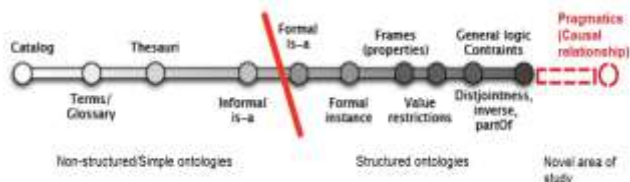

Figure 2. Evolution of Formal Ontology.

There have been proposals for the inclusion of pragmatic in a knowledge model for a more complete and meaningful information exchange, see Figure 2 (Jan Mendling 2007). A formal pragmatic can provide better rational and scientific foundation for an integrated ontology theory as well as practice

that extends semantics (Akkermans, 2008). The major aim of pragmatic is to support putting ontologies in context, thus future research should be heading this direction (Giboin, Denis, #233, & Snoeck, 2011).

B. Role of Pragmatic

Less attention has been given to the pragmatic aspect of ontology. The role of pragmatic in relation to ontology can best be illustrated as Figure 3. Most works have been done in the area of semantics but few are actually in pragmatic.

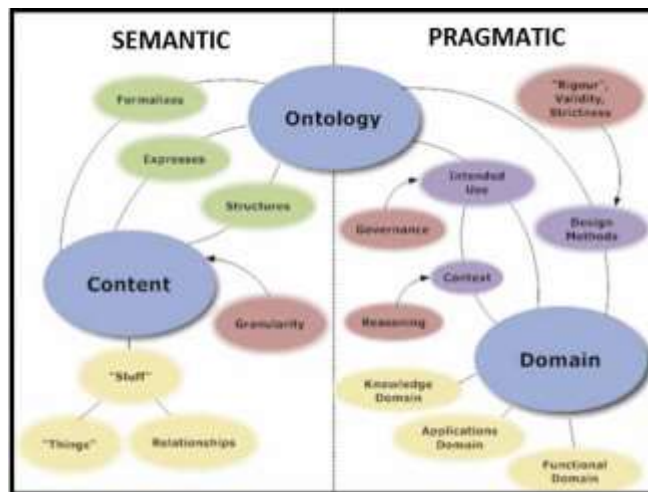

Figure 3. Ontology Framework (Gruninger, Bodenreider, Olken, Obrst, & Yim, 2008)

The figure below illustrates the conceptual relationship of pragmatic with other body of knowledge and applications. The pragmatic perspective is the specific structure of knowledge model that deals with actionable knowledge. It can be viewed as a subset of the domain knowledge model.

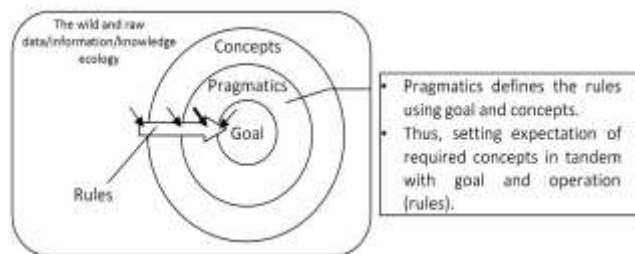

Figure 4. Working definition of pragmatic.

V THE PRAGMATIC ARCHITECTURE

We propose to lay emphasis on the pragmatic perspective to drive the design of the ontology and application system. Pragmatic can optimize the right size of ontology for usage. Figure 5 below illustrates the conceptual relationship of pragmatic with another body of knowledge and applications. The pragmatic perspective is the specific structure of knowledge model that deals with actionable knowledge. It can be viewed as a subset of the domain knowledge model.

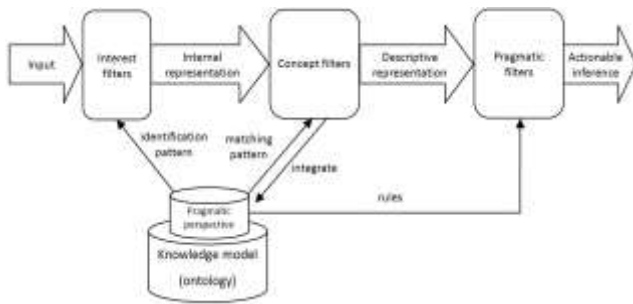

Figure 5. Proposed Pragmatic Architecture

Pragmatic provides patterns and rules to the application system. Interest filters help the system to focus on relevant data/information/knowledge. Concept filter assigns system's meaning to the information. The system uses its own experience, in the form of vocabulary provided by its internal formal knowledge, to describe the representation. This process integrates the internal representation of the input with the model. The pragmatic perspective provides a set of rules associated with the descriptive representation to the inference engine. Naturally, pragmatic should work well with rule-based engine due to the nature of the representation semantics. The outcome of the engine will be actionable inference with respect to the domain knowledge problem solving requirements.

Pragmatics basically provides the problem solving requirements which can be generic as well as domain-specific. To handle generic functions, pragmatic in ontology can be used to check for the truth of an antecedent concept and thus trigger the truth of the consequential concept. From the context of integration, this can be used to check if a relevant piece of information is available to the user, or if the information should be updated. If the information is unavailable, then the search or the capture should be conducted. It is also essential in some application of information that certain information (upon availability or upon unavailability) should become an event that triggers awareness of decision-makers. Examples of domain-specific functions include findings such as missing of information, a possible factor for an outcome, or an outcome of a set of interrelated incidents. All these will trigger use actions.

The firing of pragmatic concepts may be coordinated by a mechanism. Concepts that are similar, or having subsumption relationship, may fire together. Concepts that have a direct causal relationship, may fire consecutively. If the concepts are stimulated repeatedly, the connection between the two becomes stronger, through update of the strength property of a connection.

Conventionally, when the ontology is not expressive enough, the rule layer will be added on top of the

ontology layer. A suitable language for rule such as SWRL will be used to express rules in terms of OWL concepts of classes, properties and individuals.

A possible application of pragmatic design is to improve knowledge integration. This is done by developing pragmatic ontologies which are proposed to be more compatible with rule-based systems. Pragmatic refer to a structure that captures and encodes business rules that serve as the driver for integration. Business rules as triples provide causal relations between the antecedent object and the consequent object. Antecedent includes event whereas consequent includes an expected outcome. An event triggers transition to consequent based on properties of the antecedent. The properties of the antecedent are taken from the ontology concepts. Causal relation can maximize rule-based manipulation of ontology and generation of rules that are coupled with facts in the ontology to help with the integration.

The basis of claim that pragmatic can improve integration is derived from overlaps of several postulations:-

- Belief-Desire-Intention (BDI) model for intelligent agent programming. BDI model is used as a programming paradigm to set the world model that software accepts as true (Belief) and form the basis of processing; desire is the state that is achievable, and intention will be a selected function or a set of selected functions to achieve the desire. The BDI model is pragmatic in nature which can be implemented as a set of guided rules.
- Function-Behaviour-Structure (FBS) ontology model for design process. FBS model can be used to extend the Intention component of BDI. The function is achievable by setting the expected behaviour of the software and this can be implemented by using one or combining a few components (Structure).
- Information Integration Theory (IIT) is an awareness phenomenon model that attempts to simplify awareness as activities of merging information that results in an information amount that is bigger than the sum of the merged information [Tononi, 2015 #699].

VI PRAGMATIC METHODOLOGY

Various methodologies have been proposed with different goals, functions and levels of abstraction in mind (Dehghani & Ramsin, 2015; Hooi, Hassan, Abidin, Arshad, & Shariff, 2015). Generically, developing ontology begins with a specification of ontology requirement which specifies the scope through use cases, expert inputs, competency

questions, brainstorming or by referring to existing ontology structure or vocabulary (Chen, 2004).

The next step is conceptualization whereby terms are identified and described using middle-out, top-down or bottom-up strategies (Gawich, Badr, Hegazy, & Ismail; Gómez-Pérez, Fernández-López, & Corcho, 2004; Uschold & Gruninger, 1996). Middle-out strategy focuses on most relevant concept first and is claimed to be more stable and easier (Uschold & Gruninger, 1996).

Few methodologies specifically measure the amount of knowledge for each task (Dehghani & Ramsin, 2015; Sarnikar & Deokar, 2010). The criteria for determining knowledge intensity has been proposed by Eppler et al in (Eppler, Seifried, & Ropnack, 1999).

Pragmatics methodology is proposed to adopt middle-out approach, but more specifically to capture actionable concepts. The last step is to implement the concept by formalizing them into a suitable format such as OWL for facts and SWRL for rules. In this way, applications can use SPARQL query to retrieve information and achieve knowledge discovery.

A. Process and Tools Support Pragmatic

Figure 6 below shows the processes and tools that can be used in the analysis and design of software in the conventional software development sense. In the proposed methodology, these tools can be used to acquire the concepts and rules needed by the ontology. To bridge the objects with the process, we propose the use of a modified Class-Responsibility-Collaboration (CRC) tool. CRC is a diagrammatic tool in object modelling. With some modification, the findings of tools used in process modelling can be included in object-modelling.

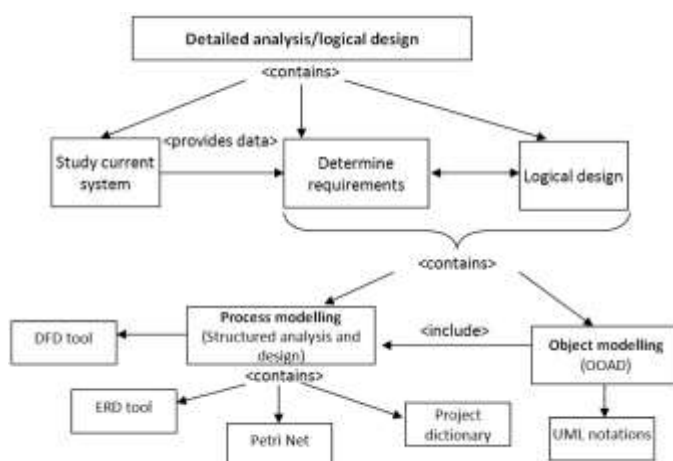

Figure 6. Analysis and design tools.

B. Responsibility-Class-Collaborator (RCC) to Class Responsibility-Collaborator (CRC) Technique

Conceptualization can be done using Class-Responsibility-Collaboration (CRC) frame, as shown in Figure 7. This is modeled after CRC card, a brainstorming tool for quick conceptualization. CRC constrains unnecessary responsibilities. This is an important property of CRC because pragmatic is about focusing on the necessary task and knowledge only.

The constraint can be further improved by developing Responsibility-Class-Collaborator (RCC) frame first. Similar to CRC, RCC proposed here begins with identifying activities, its processes and its tasks. Then, for each task, identify the properties. To systemize the design, the following frame can be used:

Responsibility (R)		
Class1,C1	Collaborator1, Co1	Trigger, temporal, location, personal, collaborator state change
Class2,C2	Collaborator2, Co2	Trigger, temporal, location, personal, collaborator state change
Class3,C3	Collaborator2, Co2	Trigger, temporal, location, personal, collaborator state change
Class2,C2	Collaborator3, Co3	Trigger, temporal, location, personal, collaborator state change

Figure 7. RCC Frame

The following steps are recommended to find the pragmatic concepts and relations:

1. Start by writing a scenario, and then identify the major actions and corresponding actors.
2. Develop RCC frames to describe the actions.
 - a. Actions become responsibilities (R).
 - b. R is a causal relationship and is defined as the methods that will alter one or both actors' values or states. Collaborators (Co) refer to other actors with whom this actor (aka Class (c)) has causal relationship with. Co is the other class that becomes the object of the relationship; whereas C is the subject and R is the predicate.
 - c. Identify properties of R that becomes relevant to the C-Co pair. There should be information on triggering event, parent of responsibility, temporal properties, location properties and person-in-charge.
 - d. Identify parent-child relationship between R and store this in a R-

- Hierarchy list or table. Identify R between the same C-Co pair or based on expert or guideline information.
3. RCC frames can be collectively presented as a table. The table will have rows of R_1 to R_n . Then, the columns will be populated with Classes, and the cell will be populated with corresponding collaborators. This becomes the RCC table, which is a collection of RCC frames.
 4. Convert RCC table into CRC frames:
 - a. Read the column followed by row and finally cell. Iterate this for the table. This will generate a collection of CRC frames, as shown in Figure 8.
 - b. There should be some information about R, such as if it is a static method or a dynamic rule. This part requires some analysis to see if it is a standard task or context specific and if it has any inferencing property.
 - c. Other properties of R are inherited from RCC.
 - d. Each CRC frame is inspected for parent-child relationship. Store this information in a separate Class Hierarchy list or table.
 - i. Each frame has a relevant class/object in the design.
 - ii. Arrange the frame, placing it in closer proximity if the classes/objects are highly related. Class-type relationships are identified.

Class (C)	
Responsibility1, R1	Collaborator1, Co1
Responsibility2, R2	Collaborator2, Co2 Collaborator3, Co3
Responsibility3, R3 Responsibility4, R4	Collaborator4, Co4

Figure 8. CRC Frame

5. Evolve CRC into a class diagram and ontology.
6. Evolve RCC into corresponding rules. Fixed rules such as commonly used techniques or algorithms are translated into methods to be incorporated into class diagram. On the other hand, business rules that may evolve are translated into rule bases.

C. Pragmatic Ontology Design

Inputs from RCC provide the components, properties and relations as building blocks of the ontology. The ontology will subsequently have a significant number of object properties with corresponding domain and range entities:-

- a. The object property can then be compared with other object properties of the ontology using hierarchical relation, properties (functional, inverseFunctional, symmetric or transitive) and refined with restriction.
- b. Determine rules and axioms from the object properties.
- c. Develop ontology from the entities in the relations by establishing relations:- subsumption, equivalent or disjoint.
- d. Generate knowledge rules SWRL from the ontology.

The expected output based on the proposed approach using RCC-to-CRC technique is a slimmer pragmatic ontology which can be mapped and is traceable between classes' method, classes' attributes and system rules.

VII DISCUSSION

The methodology is best evaluated through empiric evaluation. The proposed pragmatic methodology is best used with process-based problems which require rich information and knowledge support. Various real-world problems such as clinical diagnosis, loan processing and process safety management in chemical plants may benefit from this.

In particular, pragmatics can provide a richer integration. Ontology has been mainly exploited for its semantic support but many problems in the real world are process-based. Vocabulary based on process is necessary and the capability to make use of existing rule-based systems will further boost the potential of ontology to be used for dynamic and continuous information as well as knowledge integration.

Most knowledge system methodologies do not have empiric backing but are evaluated based on the comparison with existing methodologies or by theoretical arguments. This is based on the findings by (Dehghani & Ramsin, 2015) which has also proposed criteria-based evaluation. This work has been evaluated using the development-related factors of Table V in (Dehghani, 2015 #722). The result is satisfactory achieving 80% of the criteria. However, the criteria metric is very general, i.e. giving only positive or negative as the yard stick. The result of the evaluation is given in Appendix I.

VIII CONCLUSION

This paper proposed a working definition of the pragmatic aspect of ontology. It has argued that most methodologies for knowledge engineering do not provide sufficient detail when capturing and designing a pragmatic model. This paper has shown the use of RCC-to-CRC, an adaptation of CRC card used in requirements elicitation, as a viable approach to capture and build a pragmatic ontology. A pragmatic ontology has the benefit of maximizing

representation of rules in ontology. This will facilitate coupling with rule-based systems and access to rule generation facility. The difference brought by this approach is that the rules are semantically richer by coupling with facts ontology.

ACKNOWLEDGMENT

The authors would like to thank the management of Universiti Teknologi PETRONAS (UTP) for rendering support to this research and Process Safety group of UTP and PETRONAS Penapisan Melaka for knowledge sharing.

REFERENCES

- Akkermans, H. (2008). *The Business of Ontology calls for a Formal Pragmatics*. Paper presented at the Proceedings of the 2008 conference on Formal Ontologies Meet Industry,
- Anthony Debons, N.-G. D. (2000, November 29-30, 2000). *Need of Education and Training for Information Science*. Paper presented at the Proceedings of XIth Annual Symposium on Reliability and Quality Assurance, Bucharest.
- Basil Ell, E. S., Stephan Wölger, Benedikt Kämpgen, Simon Hangl, Denny Vrandečić, Katharina Siorpaes. (2011). *Enterprise Knowledge Structures Context and Semantics for Knowledge Management* (pp. 29-59).
- Benaroch, M. (2002). Specifying Local Ontologies in Support of Semantic Interoperability of Distributed Inter-organizational Applications. *Next Generation Information Technologies and Systems - Lecture Notes in Computer Science*, 2382(2002), 90-106.
- Calvanese, D., Giacomo, G. D., Lembo, D., Lenzerini, M., Poggi, A., & Rosati, R. (2007). *Ontology-based database access*. Paper presented at the Proceedings of the Fifteenth Italian Symposium on Database Systems.
- Camlon H. Asuncion, M. J. S. (2010). Pragmatic Interoperability: A Systematic Review of Published Definitions. *Enterprise Architecture, Integration and Interoperability*(326), 164-175.
- Chen, H. (2004). eBiquity Group Meeting. Retrieved from
- Dehghani, R., & Ramsin, R. (2015). Methodologies for Developing Knowledge Management Systems: An Evaluation Framework. *Journal of Knowledge Management*, 19(4), 682-710.
- Eppler, M. J., Seifried, P. M., & Ropnack, A. (1999). *Improving knowledge intensive processes through an enterprise knowledge medium*. Paper presented at the Proceedings of the 1999 ACM SIGCPR conference on Computer personnel research, New Orleans, Louisiana, USA.
- Gawich, M., Badr, A., Hegazy, A., & Ismail, H. (2012). A Methodology for Ontology Building. *International Journal of Computer Applications*, 56(2), 39-45.
- Giboin, A., Denis, B., #233, & Snoeck, I. (2011). *Taking "pragmatic dimensions" of ontologies into account: frameworks*. Paper presented at the Proceedings of the 7th International Conference on Semantic Systems, Graz, Austria.
- Gómez-Pérez, A., Fernández-López, M., & Corcho, O. (2004). *Ontological Engineering X*. Wu & L. Jain (Eds.),
- Gonçalo Antunes, M. B., Rudolf Mayer, José Borbinha, Artur Caetano. (2014). Using Ontologies for Enterprise Architecture Integration and Analysis. *Complex Systems Informatics and Modeling Quarterly (CSIMQ)*(1), 1-23.
- Gruber, T. R. (1993). Toward Principles for the Design of Ontologies Used for Knowledge Sharing. *International Journal Human-Computer Studies*, 43(4-5), 907-928.
- Gruninger, M., Bodenreider, O., Olken, F., Obrst, L., & Yim, P. (2008). Ontology, taxonomy, folksonomy: Understanding the distinctions, Applied Ontology. *Ontology Summit 2007*, 3(3), 191-200.
- Hooi, Y. K., Hassan, M. F., Abidin, A. I. B. Z., Arshad, N. I. B., & Shariff, A. M. (2015, 24th August 2015). *A Generic Ontology Methodology and Factors to Address Design Consistency*. Paper presented at the 5th International Conference on IT Convergence and Security 2015 (ICITCS 2015) Kuala Lumpur.
- Jan Mendling, J. R. (2007). Extending the Discussion of Model Quality: Why Clarity and Completeness may not always be enough *19th International Conference on Advanced Information Systems Engineering (CAiSE 2007)* (Vol. 365, pp. 109-121). Trondheim,, Norway: Tapir Academic Press.
- Kalfoglou, Y., & Schorlemmer, M. (2003). Ontology Mapping: The State of the Art. *Knowl. Eng. Rev.*, 18(1), 1-31.
- Kuo, Y.-T., Lonie, A., Sonenberg, L., & Paizis, K. (2007). *Domain ontology driven data mining: a medical case study*. Paper presented at the Proceedings of the 2007 international workshop on Domain driven data mining, San Jose, California.
- Neches, R., Finin, R. F. T., Gruber, T., Patil, R., Senator, T., & Swartout, W. R. (1991). Enabling Technology for Knowledge Sharing. *AI Magazine*, 12(3), 35-36.
- Noy, N. F., & McGuinness, D. L. (2001). *Ontology Development 101: A Guide to Creating Your First Ontology*.
- Sarnikar, S., & Deokar, A. (2010, 5-8 Jan. 2010). *Knowledge Management Systems for Knowledge-Intensive Processes: Design Approach and an Illustrative Example*. Paper presented at the System Sciences (HICSS), 2010 43rd Hawaii International Conference on.
- Thompson, I. (2005). Pragmatic Ontology I: Identifying Propensity as Substance. *Generative Science*. Retrieved from
- Uschold, M., & Gruninger, M. (1996). Ontologies: Principles, methods and applications. *Knowledge Engineering Review*, 11, 93-136.
- Van Heijst, G., Schreiber, G., Wielinga, B. (1997). Using Explicit Ontologies in KBS Development. *Int. J. Human-Computer Studies*, 46, 183-292.
- Wache, H., Vögele, T., Visser, U., Stuckenschmidt, H., Schuster, G., Neumann, H., & Hübner, S. (2001). *Ontology-Based Integration of Information - A Survey of Existing Approaches*. 108-117.

APPENDIX A: Evaluation of pragmatic methodology using success/failure factors of Knowledge Management System development process (Dehghani & Ramsin, 2015).

Criteria for evaluation of special features of KMS development methodologies-based on success/failure factors			
Name		Type	Result
Determination of appropriate tools and technologies		Multilevel	<input type="checkbox"/> Enforced <input checked="" type="checkbox"/> Not enforced, but using specific tools and technologies is advised. <input type="checkbox"/> Not addressed.
Support for KM process.	Embed knowledge-source detection features like knowledge-map	Binary	Positive
	Periodical evaluation of knowledge content	Binary	Positive
	Embedding knowledge storage features	Binary	Negative
	Monitoring the KM process	Binary	Negative
Prototyping		Binary	Positive
Embedding diverse channels for knowledge transition		Binary	Positive
Embedding required features to access the knowledge at any Time and Place		Binary	Positive
Specification of the requirements at Different Levels of Users		Binary	Negative.
Specification of the appropriate time to obtain the Knowledge		Binary	Negative.
Documenting the Problem and System Domain Definition Concepts		Binary	Positive
Specification of appropriate Architecture		Binary	Positive
Specification of Organizational Knowledge Taxonomy		Binary	Positive
Identification and Encoding of Expert Knowledge		Binary	Positive
Prioritization		Binary	Positive
Providing documents for Development and Maintenance Phases		Binary	Positive
Embedding features to receive request knowledge by users		Binary	Negative
Embedding features for monitoring justice-based efficiency of KMS		Binary	Negative
Support for management of human resources		Binary	Negative
Gathering knowledge based on Knowledge Requirements		Binary	Positive
Compatibility check of selected technologies		Binary	Negative
Formation of Maintenance Team(s)		Multilevel	<input type="checkbox"/> Addressed the formation of maintenance team(s) and has provided criteria for selecting team members. <input type="checkbox"/> Only addressed the formation of team(s). <input checked="" type="checkbox"/> Not addressed.
Checking compatibility with other organizational systems.		Binary	Positive
Embedding the features for monitoring knowledge flows.		Binary	Positive
Provision of methods to extract hidden knowledge of experts		Binary	Negative
User-friendly UI design		Binary	Negative
Basis in practical experiences		Binary	Positive
Periodical validation		Binary	Positive
Embedding knowledge-sources search features		Binary	Negative
Prevention of invalid knowledge encoding		Binary	Positive
Determination of characteristics of organizational knowledge	Determining security levels of organizational knowledge.	Binary	Negative
	Determining obstacles to achieve organizational knowledge.	Binary	Negative
Attention to distinctive characteristics of tacit and explicit knowledge.		Binary	Negative
Planning for tacit KM		Multilevel	<input type="checkbox"/> Specifically enforced. <input checked="" type="checkbox"/> Generally enforced. <input type="checkbox"/> Not enforced.
Detection of organizational knowledge flows			<input type="checkbox"/> Activities are specified for knowledge flow discovery. <input checked="" type="checkbox"/> Only guidelines are provided for this task. <input type="checkbox"/> Not addressed.

Knowledge Integration Improves Flood Disaster Management: A Case Study of Kemaman

Nor Hidayati Zakaria¹, Mohammad Nazir Ahmad¹, Mohd Saiful Anuar Mohd Noor², and Mazida Ahmad³

¹Universiti Teknologi Malaysia, Malaysia, {hidayati, mnazir}@utm.my

²Kemaman District and Land Office, Terengganu, Malaysia, saifulm.noor@gmail.com

³Universiti Utara Malaysia, Malaysia, mazida@uum.edu.my

ABSTRACT

This paper discusses the flood knowledge integration practices that have been applied in the flood management team of Kemaman District, Terengganu, Malaysia. The Kemaman District was announced to be the first district who had achieved a Gold Standard for flood disaster management practices. Accordingly, this study applies a case study approach by means of: interviewing key informants; studying archival documents; and conducting site visits to flood locations so as to better understand the achievement of the district's flood management team. The result shows the importance of knowledge integration as one of the factors contributing to the success of the district's flood management plan.

Keywords: Knowledge integration, flood disaster, flood management.

I INTRODUCTION

Persistent flooding has always been associated with the East Coast states of Malaysia, especially Terengganu and Kelantan. In 2013, the Kemaman District in Terengganu (as shown in Figure 1) was one of the worst-hit areas, suffering the worst flooding since 1971. More than 20,000 people were evacuated to relief centres when all roads were closed and communication with the outside was not possible. Such an unexpected situation resulted in the district becoming virtually an island after being cut off in all directions (The Star, 2013). As a consequence, the immense flooding literally paralysed Kemaman as power lines had to be disconnected for safety reasons (Daily Express, 2013). There was also an ensuing shortage of food and basic necessities.

Having learnt from this incident which caused utter chaos in 2013, the Kemaman District Office initiated a sort of systematic plan to prevent the situation from re-occurring. This then led the district's flood management team to achieve a gold standard as announced by the Malaysian Prime Minister in 2014. This paper aims to examine and ultimately understand just what is so special and unique about the Kemaman District's flood management practices that resulted in its earning the Gold Standard benchmark for

Malaysia. To achieve this intention, we specify our study on the knowledge flood integration perspective.



Figure 1. A Map of Kemaman District.

Having learnt from this incident which caused utter chaos in 2013, the Kemaman District Office initiated a sort of systematic plan to prevent the situation from re-occurring. This then led the district's flood management team to achieve a gold standard as announced by the Malaysian Prime Minister in 2014. This paper aims to examine and ultimately understand just what is so special and unique about the Kemaman District's flood management practices that resulted in its earning the Gold Standard benchmark for Malaysia. To achieve this intention, we specify our study on the knowledge flood integration perspective.

II THE RESEARCH BACKGROUND

In December 2014, the Prime Minister of Malaysia announced that the Kemaman District's flood management plan would become the model for the standard operating procedure (SOP) for flood management in flood-hit areas.

Flood disaster management principles highlight the accuracy and speed that is required for a compilation of information to enable decision-making and forecasting purposes. From the disaster management point of view, knowledge management (KM) has been perceived as an important element for the procurement of disaster-related data (Seneviratne et al. 2010). Flood management processes in Malaysia are confronted with numerous challenges. Multiple organizations were engaged in the disaster

management process without having proper documentation as to how to determine the respective roles of cross-agencies and authorities. Up until now, there has not been any clarity with regard to the sharing and integration of knowledge between agencies and authorities.

The existing practice of flood management in Malaysia is generally weak in terms of information-sharing and lack of coordination between agencies (Mohd Rodzi, Zakaria & Ahmad, 2016). Realizing the importance of knowledge integration (KI) within the context of KM, this research proposes a KI for flood management in Malaysia, where the KI is identified as an important aspect in flood management.

Grant (1996) viewed KI within the lens of an organisation as a process of integrating knowledge of experts among the employees. From a different point of view, Enberg et al. (2006) explored the dynamism of KI from the perspective of acting and interacting in a team. Their approach emphasized the importance of the project management function in assuring KI by appreciating the learning dynamic with reference to the project context. In agreement with Mohd Rodzi et al. (2014), this research has established that KI is a process of combination by which to produce new knowledge. In addition, it includes the process of recognizing knowledge in comparative fields and incorporating this so as to create new knowledge. Thus, it is envisaged that a solution can be conveyed to solve problems and may subsequently reduce the complexity of tasks. Hence, we argue that integrated knowledge is highly valuable as a possible solution to any problems encountered by flood management teams in Malaysia.

III THE RESEARCH METHODOLOGY

This study entails a case study approach by means of: interviewing key informants from the Kemaman District Office; interviewing representatives of Committee of Community Development (JKKK) and the Smart Community team through open-ended interviews; and studying archival documents. In addition, the authors gathered observations through digital photographs, as well as site visits to three flood locations (examining flood sensors and flood telecommunication equipment at Kampung Air Puteh, relief centres and food depots). During these visits, the authors made observations and recorded them via file notes and digital photographs. Archival documents related to meeting agendas, planning of activities, procedures and letters provided further data. These methods have driven the authors to analyze actual situations and initiatives that have been implemented.

IV RESULTS AND DISCUSSION

Since April 2014, a flood disaster committee had been formed and 69 relief centres were identified. Preparation of an operation was set up by district authorities to be used in pre, during and post-flood event phases with regard to the worst case scenarios.

A. Pre-Flood Phase Plan

In the pre-flood phase, various flood awareness programs were conducted by local and national authorities. These included the district authorities, National Security Council (MKN), youth club, medical teams and logistics support respectively. The activities covered basic information such as: how to handle a flood crisis; assembling flood kits for victims and relaying of information regarding relief centres. Placement centres, cooking areas, food depots and places to store items donated by the public were also identified during this period. The level of readiness among the secretariat was tested through the flood simulation process, which includes: essential items receipt; registration of victims with the allocated relief centres; food management and distribution of victims' goods.

All required equipment items were identified and tested in order to facilitate the disaster management operations before the onset of the flood season. Those equipment items comprised generator sets and logistic equipment such as: boats; walkie-talkies and the portable mobile cellular sites that provide temporary network and wireless coverage in locations where cellular coverage is either minimal or compromised. The district authority works closely with telecommunications companies like Celcom Axiata Bhd, Maxis Bhd, DiGi.Com Bhd and Telekom Malaysia Bhd to ensure that the communications system remains effective during flood events. This required and up-to-date knowledge is planned to be well-shared and integrated among the affected victims and relevant agencies through WhatsApp and Telegram social media application software programmes.

Each flood relief centre is equipped with temporary clinics to check on the health condition of flood victims (NST, 2014). Hospital also list vulnerable patients including expectant mothers who are due to give birth during the flood season for contingency plans (The Star, 2015). In addition, the district has three helipads complete with global positioning system (GPS) coordinates that will help cut the time required to send food and other essential assistance to victims. These are located at Batu 14 in Kuala Taylor, Felda Seberang Taylor and Pasir Gajah respectively. Since every single thing related to flood management is now well-planned in the pre-flood phase, it is no wonder that the Kemaman District's flood

management plan has turned into a success story in Malaysia.

B. During The Flood Phase Plan







Over the duration of the floods, the main operations room was activated once the first relief centre was opened for the victims. All relevant agencies were then instructed to open their own operation rooms. Meetings concerning the coordination of the various operations among all related authorities and agencies were held daily at 8.00 pm at the main operations room to report on and synchronize plans and critical activities that needed to be taken on the following day.

Seven day supplies of food were also despatched to each relief centre and food depot. This was an improvement upon the three day food supplies of the standard operating procedure of MKN existing previously. Steps were taken to ensure the relief centres were equipped with necessary items for victims such as blankets, mats, sleeping bags, gas cylinders and power banks. However, among all of those stated, efforts to rescue flood victims were still given top priority.

C. Post- Flood Phase Plan

After the floodwaters receded, the extent of damage to public property such as bridges, buildings and roads, as well as private property including houses and cars was assessed. The various district offices were given the task of centralising and managing all the contributions and donated items, such as daily essentials.

One week after the last relief centre was closed, an investigation of the flood management operations was carried out and proposals were presented to bring about further improvements. As a result of the integration knowledge and plan among authorities and agencies, the authorities as a whole concluded that the floods that hit the Kemaman district in 2014 came within control, far better than in 2013.

	<ul style="list-style-type: none"> Victims' report (statistics)
 <p>Committee of Community Development (JKKK)</p>	<ul style="list-style-type: none"> Relief centres & locations Pre-registration & actual victims Flood drills Flood instructions for pre, during and post phases of flood event Flood early warning Flood voucher
 <p>Local People</p>	<ul style="list-style-type: none"> Relief centres & locations Pre-registration Flood early warning Flood voucher
 <p>Relief Centre</p>	<ul style="list-style-type: none"> Pre-registered victims Actual victims Food stock & meals preparation Flood relief items Required items
 <p>Community Welfare Department (JKM)</p>	<ul style="list-style-type: none"> Flood preparation Food stock Food relief items Registered victims Registration slip Relief centres & food depot
 <p>Flood Management System (FMS)</p>	<ul style="list-style-type: none"> Weather forecast Water levels Images (CCTVs, map) & flood sensors Flood early warning Relief centres Registered victims Flood donations Support ticket Flood voucher
 <p>Main Operation Room</p>	<ul style="list-style-type: none"> Coordination meetings Emergencies notifications Water level (JPS*) Closed/open roads (JKR*) Weather forecast (Meteorology) Flood actions by agencies Assets provided by agencies Victims' report (statistics) Instruction & information from MKN* (District & State)

*JPS: Department of Irrigation and Drainage

*JKR: Public Works Department

* MKN: National Security Council

Table 1. The Integrated Flood Knowledge.

 <p>District Office</p>	<ul style="list-style-type: none"> Flood preparation Pre-registration for victims Flood drills Relief centres & locations Assets movements Application for flood assets to agencies Flood instructions for pre, during and post phases of flood event Flood donations Food depot Flood voucher Instruction & information from MKN* (District & State)
--	--

Table 1 exemplifies necessary flood knowledge that was shared and integrated among authorities and agencies of Kemaman's flood management team. The integration of flood knowledge has helped to improve flood disaster management strategies to enable them to better adapt to particular situations.

D. Integrated Flood Knowledge Management Activities

Flood knowledge was integrated in teams having a diversity of authorities, agencies, backgrounds and disciplines. The main integration management team consists of authorities and agencies as illustrated in Table 1. In order to have better knowledge integration, those authorities and agencies need to realize their different roles and responsibilities. Recognizing the fact that every function needs sufficient communication helps to combine knowledge for improving flood management in a team. For example, the input of both human and technology factors such as the Committee of Community Development (JKKK) and Flood Management System (FMS) reduces the vulnerability of victims by improving preparedness and early warning systems. This subsequently enables them to better adapt and respond.

The emergence of new innovations in social networks with communication instruments can ease the numerous processes involved in widespread distribution of knowledge. The most popular social networking sites such as WhatsApp and Telegram have been used as part of the communication tools for the Kemaman District's flood management team. This integration of knowledge which was provided by different actors has helped to develop successful strategies to mitigate the impact of flooding in that district.

Develop Strong Teamwork. To provide vulnerable victims with supports and strategies by which to cope with a flood disaster, a group of representatives from local people, known as the Committee Community Development (JKKK) have been working together with Kemaman District authorities and government agencies. These agencies include: National Security Council (MKN); Community Welfare Department (JKM); Fire and Rescue Department (JPBM); Royal Malaysia Police (PDRM) and others. This strong team was built after the 2013 flood tragedy in the district in response to suggestions and responses. Their resources were allocated as closely as possible to the point of delivery services. Each authority and agency in the team shared the same interests, vision, and objectives by integrating their knowledge in improving the procedures and plan for flood management. Adequate and sufficient arrangement was organized to provide accountability for every authority and agency. The created team is accountable for providing a rapid

response to any relevant necessary actions and tasks. By having frequent face-to-face meetings, this team actively tries to avoid the proliferation of misleading information.

Interestingly, the participation of representation by local people in the team is proactively encouraged. The Kemaman District Office has initiated small functional groups (known as JKKK) as one of its effective ways in strengthening flood preparedness at the community level. Each group represents a specific village or catchment area in the Kemaman district. This community involvement is significant for providing a bridge of knowledge from local people to authorities and agencies. This knowledge would generally encompass information such as incident reports in the community. Strong community engagement is required to produce long-term success of flood disaster management as it is the best way to enable communities to be more participative, cooperative and organised by linking them with the official flood disaster agencies.

Re-Structure of Normal Standard Operating Procedure (SOP) for Registration and Food Supply Processes. Subsequent to a considerably anxious moment during the flood incident in 2013, the Kemaman District Office has taken an initiative to expedite certain procedures in their flood management plan such as the normal process of victims' registration and food supply as stated in its Standard Operating Procedure (SOP).

A district office was opened to enable pre-registration of potential flood victims by involving the Committee of Community Development (JKKK) in the pre-flood phase. This pre-registration process was performed through filling out registration forms facilitated by JKKK. These are then forwarded to the district office to be confirmed and subsequently keyed-in into the Flood Management System (FMS). The pre-registration data will be used during the flood and post-flood phases by the district office, relief centres, Department of Community Welfare (JKM), JKKK and main operation room to validate the actual victims for flood support and voucher distribution. Surprisingly, this initiative shortened the flood time management process from one year to a period of only three months. This ultimately saved about nine months in the management process.

Further, an improvement was taken to ensure flood victims were given full and continuous meal support by supplying seven day food supplies ahead at food depots. This procedure saw an improvement in a further four days from the original three day food supplies of existing standard operating procedure that was stated by the National Security Council (MKN) and the Community Welfare Department (JKM).

The Flood Management System. Technical information alone without consideration being given to both technical information and local wisdom might result in the failure of the system that was being developed. In Kemaman, the flood management system (FMS) has been developed by the Smart Community Team for managing flood data of the district. This enables the system to produce, specifically: flood early warnings; flood forecasting; flood risks in catchment areas; flood reports and other necessary actions. This initiative is very useful for both contingency planning and immediate actions in responding to a flood crisis. When the river's water level reaches a certain point, a flood warning will be broadcast by the system to all registered local people in affected communities, as well as their JKKK. Two modules are involved in this situation, known as *Floodforecasting* and *My Alert*. *My Alert* module also distributes information concerning evacuation centres for the specific catchment area. In some cases, local people might not understand the distributed flood alert information. Thus, a combination of JKKK explanation and instructions help to facilitate the understanding of the community in terms of taking decisions on evacuation and preventive actions. It also serves to intensify efforts to assist flood victims, especially those living in areas badly affected by the floods.

V CONCLUSION

The flood management plan for the Kemaman District has achieved Gold Standard benchmark compared with other flood management teams in Malaysia. As discussed in this paper, KI has been found to be one of the factors contributing to the success of the district's flood management team. This has been achieved with facilitation by technologies such as FMS, social media applications of WhatsApp and Telegram, and flood sensors respectively. Indeed, leadership seems to play an important role in the whole situation.

However, future improvement still needs to be considered. Current lessons learned from the Kemaman District's flood management team triggers recognition of a few issues that need to be enhanced to provide a better flood management plan. First, we see

that the risk management aspect for the affected community is still limited. Second, a flood prediction data model from rainfall also needs to be included in the FMS, so as to assist with existing flood forecasting module of river water level measurement. Lastly, the measurement of river water level in the FMS needs to be improved so as to obtain an accurate result for flood prediction catchment areas and, accordingly, to advise local people to be prepared to face the possibility of floods as forecast by the system.

ACKNOWLEDGMENT

This research was supported by the Long Research Grant Scheme, funded by The Ministry of Education. The authors would like to thank the District Office of Kemaman, Terengganu and the Smart Community team for their support and for generously providing information.

REFERENCES

- (30 December 2013). Kemaman suffers worst flood in 50 years. *Daily Express*. Retrieved from <http://www.dailyexpress.com.my/news.cfm?NewsID=87684>
- (6 December 2013). One dead, two missing as flood situation worsens. *The Star*. Retrieved from <http://www.thestar.com.my/news/nation/2013/12/06/one-dead-two-missing-as-flood-situation-worsens-kemaman-like-an-island-after-being-cut-off-in-all-d/>
- Abdullah, Z. (20 November 2014). Clinics at all Terengganu flood relief centres. *New Straits Times*. Retrieved from <http://www.nst.com.my/node/54798>
- Enberg, C., Lindkvist, L. & Tell, F. (2006). Exploring the dynamics of knowledge integration acting and interacting in project teams. *Management Learning*, vol. 37, no. 2, pp. 143-165, 2006.
- Grant, R. M. (1996). Toward a knowledge based theory of the firm. *Strategic Management Journal*, vol. 17, Winter Special Issue, pp. 109-122, 1996.
- Hamdan, N. (25 November 2015). Kemaman prepared to face flood season. *The Star*. Retrieved from <http://www.thestar.com.my/news/nation/2015/11/25/kemaman-prepared-to-face-flood-season/>
- Mohd Rodzi, M. R., Zakaria, N. H., Ahmad, M. N. & Yahya, H. (2014). Towards a knowledge management framework for disaster management in Malaysia. *IOS Press*, 417-431.
- Mohd Rodzi, M. R., Zakaria, N. H. & Ahmad, M. N. (2016). Ontology Based Knowledge Integration Framework For Managing Flood In Malaysia. *Journal of Advanced Management Science*, 4(6), 475-478.
- Seneviratne, K., Baldry, D. & Pathirage, C. (2010). Disaster knowledge factors in managing disasters successfully. *International Journal of Strategic Property Management*, 14(4), 376-390.

Improving Vehicular Ad hoc Networks (VANET) Communication Performance by using Time Gap Following Distance (TGFD) Model

Suzi Iryanti Fadilah¹, Mohd Helmy Abd Wahab², Azizul Rahman Mohd Shariff³, Khuzairi Mohd Zaini⁴, and Abdul Samad Shibghatullah⁵

¹³Universiti Sains Malaysia (USM), Malaysia, suziiryanti@yahoo.com

²Universiti Tun Hussein Onn Malaysia, Malaysia, helmy@uthm.edu.my

⁴Universiti Utara Malaysia, Malaysia

⁵Universiti Teknikal Malaysia Melaka (UTeM), Malaysia, samad@utem.edu.my

ABSTRACT

Today, there is a growing research study of IEEE 802.11p as one of option to help the drivers to travel more safely. Message dissemination protocols are primordial for safety vehicular applications. Periodic safety message (PSM) and Warning safety message (WSM) are two types of safety messages which may be exchanged between vehicles. In this paper we investigate the feasibility of deploying safety applications based on periodic message dissemination through simulation study with safety requirements as our priority concern. Vehicles are supposed to issue these messages constantly to inform their neighboring vehicles about their current status and use received messages for preventing possible unsafe situations on time. As reliability is the main concern in periodic message dissemination, a new metric called TGFD (Time Gap Following Distance) is defined which gives us more accurate benchmark for evaluating QoS in safety applications specifically. Thus, in order to improve the performance, the effective transmission TGFD studied.

Keywords: VANET, Time gap, time gap interval, time gap range, safety, transmission interval

I INTRODUCTION

In VANET safety applications, the research objective is to provide improvement of driver and passenger safety level by exchanging safety relevant information between neighboring vehicles. The safety information is either presented to the driver or used by ITS (Intelligent Transport System) active safety device. Some examples are: cooperative forward collision warning, left or right turn assistant, lane changing warning, stop sign movement assistant and road-condition warning. Due to the inflexible delay requirements, applications of this class may demand direct vehicle-to-vehicle communication. Each safety application requires some message exchanging between vehicles for better communication. These messages can be classified in two categories: warning safety message and periodic safety message, which have different dissemination

policies and roles in safety improvement. Warning safety messages are issued by vehicles to announce neighboring vehicles about the already happened events in a specific area of a road, like accidents, flooded road and fallen tree on the road whereas, safety messages are issued constantly. Using the received PSM vehicles try to prevent possible events (not already happened) like unexpected lane changing, forward collisions, wrong left or right turning, etc. Moreover, safety messages might be used by other applications (e.g. routing protocols). Yet messages mentioned above are complementary to each other. (Joe, & Ramakrishnan, 2015)

While WSM may be able to announce the driver in time about already happened events (accidents) in order to prevent worst incidents, safety messages can prevent many incidents before they take place. Furthermore, since WSM inform events, they are more important compared to PSM and should be disseminated with higher priority. The dissemination of WSM as well as comfort messages has been widely investigated in recent literature (Benslimane, 2004) However, to the best of our knowledge, there are quite few studies about periodic safety message dissemination and previous works are mostly discussing simplified cases which will be reviewed in the next section. In this paper, we intend to fill this gap by conducting extensive simulation study to evaluate the performance of disseminating periodic safety messages in a typical crowded traffic situation while using IEEE 802.11p. Furthermore, realizing the importance of reliability requirement in safety applications specifically, a new metric named TGFD transmission interval is defined, which gives us more accurate capability to investigate quality of service. In order to improve the performance, we study the effects of message transmission interval by using time gap (Fadilah, & Shariff, 2014).

Transmission intervals play an important role in collisions reduction. Safety-related messages are broadcasted periodically based on this transmission interval value (Mahajan *et al.*, 2006). This parameter is directly related to the requirements of the safety applications and it depends on traffic flow, vehicle speeds, and driver's behavior, among other things.

While smaller transmission interval can increase the information accuracy with frequent updates, the number of messages is also increased which may lead to a high probability of message collision. It can prevent unsafe situation in higher speeds and more unsafe conditions, it results in more saturated channel and so it is more likely to cause collision between simultaneous transmissions. To the best of our knowledge, finding the best value for this parameter has not been investigated analytically and even through simulation in the literature (Tong, et. al., 2015)

This paper is organized as follows: Section II presents our proposed Time Gap Interval system in 802.11p-based VANET. Section III presents the details of the simulation tools, the experimental environment and the methodology we followed to perform the simulations. Experimental results are described in Section IV. Section V describes the related work with regard to warning messages in VANET. Finally, Section VI presents some concluding remarks

II TIME GAP TRANSMISSION INTERVAL WARNING SYSTEM

We investigate the effects of the transmission interval is directly related to the requirements of the safety applications and should be determined based on vehicle speed, driver's reaction time, traffic density, etc. While smaller transmission interval can prevent unsafe situation in higher speeds and more unsafe conditions, it results in more saturated channel and so it is more likely to cause collision between simultaneous transmissions. To the best of our knowledge, finding the best value for this transmission interval has not been investigated analytically and even through simulation in the literature.

$$F_t = S \times D \quad (1)$$

This information is used by the drivers and active safety systems of the vehicle for preventing unsafe situations. In order to clarify our simulation scenario, we invoke some vehicle's traffic theory. From Tian, *et. al.*, (2015) we know that there are three macroscopic parameters: speed (km/h), density (vehicle/km/lane) and flow (vehicle/h/lane) of which their average values are related where F_t is traffic flow, S is mean speed and D is density. We argue that the transmission interval, denoted by TGFD, should be set in a way that all vehicles have enough fresh information about their neighbors. A vehicle can be supposed to have enough fresh information if the safety system has more up-to-date information about neighbors than the driver and so it warns the driver if he or she makes mistake.

$$T_{\text{interval}} \leq (ivD - wR) / rV \quad (2)$$

Where T_{interval} (s) stands for transmission interval time gap, ivD (m) stands for inter-vehicle distance; $wR(m)$ stands for warning radius and rV is relative speed. The awareness radius shown in Fig.1 should be relatively large to give the system in B sufficient time to be informed about any significant status (e.g. speed, position, etc.) changes of A. Therefore, if we refer to the driver's reaction by TGFD, then

$$TGFD = RT + T_{ap} + T_b + T_{pr}$$

TGFD model in this research is an extended reaction time model for VANET that also includes the transmission delay component which suitable VANET inter vehicle communication. This is because; the reaction gap of a driver seems to be an essential parameter of the car-following model. Where RT is driver reaction time, T_{ap} is application break time, T_b is VANET broadcast safety message time and T_{pr} is propagation time (Fadilah & Shariff, 2014).

$$wR \geq rV \times TGFD \quad (3)$$

The value of message transmission interval has been computed in Table 1, giving two different levels of speed $V=100$ km/h and 120 km/h and $TGFD= 1.5$ s (Fadilah & Shariff, 2014) the worst case when the vehicle in front has to stop completely. Let TGFD represent the time window duration for a safety application to work properly by receiving at least one message and assume to be transmission interval of issuing each periodic safety message.

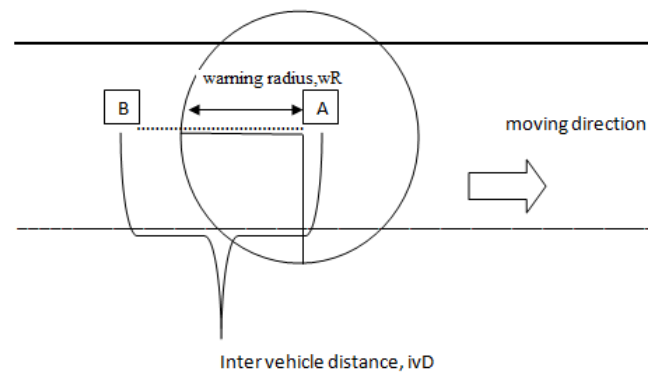

Figure 1. Message Dissemination Interval

III SIMULATION ENVIRONMENT

We conduct extensive simulations using NS2 while we make use of a deterministic radio propagation model, the two-ray-ground. A typical one-hop broadcast algorithm was implemented and the

functionality of the algorithm was examined. Each node sends UDP packets of size 100 or 200 bytes every 100 or 200 ms with a time jitter of 10%. Vehicles use transmission ranges of 50 to 300 m for message exchange (Karumanchi, S., Squicciarini, A., & Lin, D. 2015). Table 1 shows the simulation setup parameters.

Table 1. Parameter

Parameter	Value
Propagation model	Two-ray-ground
Transmission range (m)	50, 100, 150, 200, 250, 300
Carrier sense range	About twice the transmission range
MAC type	IEEE 802.11 (the base for DSRC standard)
Channel bandwidth (Mbps)	6
Traffic type	CBR (UDP)
Period of message dissemination (ms)	100, 200
Message payload size (byte)	100, 200
Number of vehicles	600
Speed (km/h)	100, 120
Traffic density (vehicle/km/lane)	50
Number of lanes	8
Simulation time (s)	60

The overall goal of this work was to evaluate the effectiveness of the TGFD transmission interval presented in section III, as well as measuring and comparing the behavior of some important metrics such as the propagation delay of warning messages, the number of blind nodes and the number of packets received per node when modifying the different parameters of a VANET scenario. The simulation results presented in this paper were obtained using the ns-2 simulator (Issariyakul & Hossain, 2011). The ns-2 is a discrete event simulator developed by the VINT project research group at the University of California at Berkeley.

Our simulated system tries to follow the upcoming WAVE standard as closely as possible. Achieving this required extending the ns-2 simulator to implement IEEE 802.11p. In terms of the physical layer, the data rate used for packet broadcasting was fixed at 6 Mbit/s. The MAC layer was extended to include different priorities for channel access.

Our methodology relied of first selecting the most representative parameters for VANET, then defining a reference scenario and, finally, varying the selected parameters, thereby generating and evaluating a large number of different scenarios. The selected parameters were: 1) the total number of vehicles, 2) the scenario size, 3) the size of the messages sent 4) the priority of these messages and 5) their periodicity. Each simulation had duration of 450 seconds. In order to achieve a stable state before

gathering data traffic, we only start to collect data after the first 60 seconds.

Finally, there are two types of nodes. Nodes that are damaged and send warning messages while the rest of vehicles that propagate these messages over the whole map area. In our experiments damaged nodes send warning packets with maximum priority (AC3) every second (TGFDwsm= 1s) and the rest of the nodes send lower priority (AC1) packets with positioning information every two seconds. These nodes also make the diffusion of the warning packets

IV RESULTS

In this paper, we intend to fill this gap by conducting extensive simulation study to evaluate the performance of disseminating TGFD transmission interval safety messages in a typical crowded traffic situation while using IEEE 802.11p (the base for WAVE standard). For this purpose, some metrics determining QoS, like delivery rate and delay have been evaluated (Wisitpongphan, N., Tonguz, O., Parikh, J. S., Mudalige, P., Bai, F., & Sadekar, V. (2007)). Furthermore, realizing the importance of reliability requirement in safety applications specifically, a new metric named TGFD transmission interval is defined, which gives us more accurate capability to investigate quality of service. In this paper we presented a warning advertisement system for IEEE 802.11p-based VANET, and we made a performance analysis of inter-vehicle communication systems to improve traffic safety. To evaluate our system we enhanced the ns-2 simulator to support the novel IEEE 802.11p technology. We selected the most representative parameters for VANET, and then we defined and simulated a basic scenario.

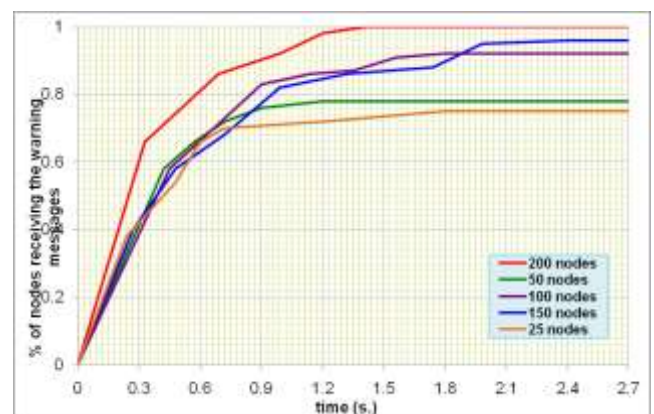

Figure 2. Average propagation delay for different size of nodes

Figures 2 show the simulation results when varying the number of nodes and maintaining the rest of parameters unaltered. We selected 25, 50, 100 (basic scenario), 150 and 200 nodes. As we expected, the propagation delay is lower when the node density increases. Information reaches about 50% of the vehicles in less than 0:3 seconds, and propagation is completed in less than 0:8 seconds. When simulating

with 200 nodes, propagation was completed in only 0:6 seconds. The behavior in terms of percentage of blind nodes highly depends on this factor. In fact, when node density is high, there are no blind nodes. This characteristic is explained because the flooding propagation of the messages works better with higher node densities. Due to collisions, the number of packets received per node slightly decreases when the number of nodes increases

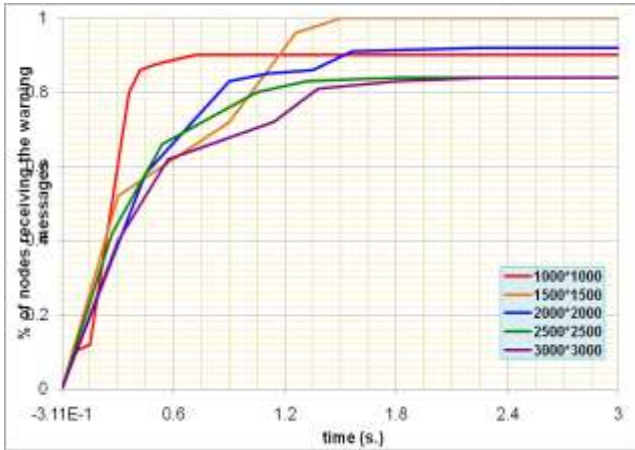

Figure 3. Average Propagation delay for different size of area

When varying the size of the area, maintaining unaltered the density of nodes and the rest of parameters. We selected scenario areas of 1000 × 1000m, 1500 × 1500m, 2000 × 2000m (basic scenario), 2500 × 2500m and 3000 × 3000m. Node density is set to 25 vehicles per square kilometer. Figure 3 depicts the average propagation delay of the warning messages. As can be seen, when the area increases, the system needs more time to inform 70% of the vehicles (approximately 0:11, 0:24, 0:31, 0:36 and 0:44 seconds respectively).

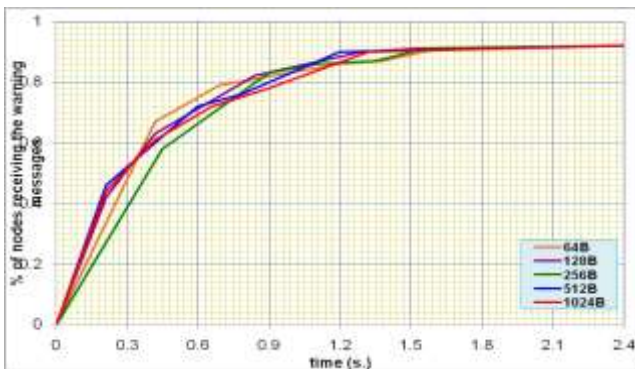

Figure 4. Average propagation delay for different size of sent packets

In this section we evaluate the impact of varying the size of the warning messages sent by nodes in terms of propagation delay. The selected values were: 64, 128 and 256 (basic scenario), 512 and 1024 Bytes. Figure 4 show the propagation delay of the simulation. As can be observed, the size of the messages sent does not affect the propagation delay

in our system since the current degree of congestion is relatively low. The system needs less than 0:34 seconds to reach to the 70% of the vehicles.

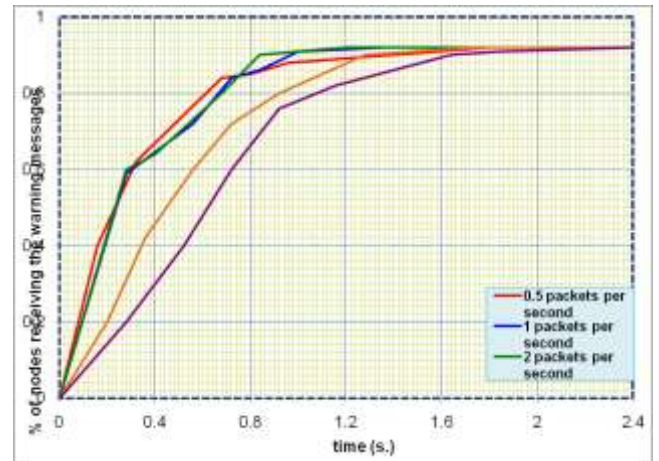

Figure 5. Propagation delay for different priority of message

In this section we vary the priority of regular (background) traffic to assess the impact in terms of warning messages effectiveness (Torrent-Moreno, M., Jiang, D., & Hartenstein, H. (2004)). Figure 5 show the simulation results when varying the priority of the messages sent by undamaged nodes, maintaining the rest of parameters unaltered. We selected AC3 (highest priority in our simulation system), AC2, AC1 (basic scenario) and AC0 (lowest priority). As can be seen, packet priority affects the propagation delay, but not to the percentage of blind nodes and the total number of messages received. The results demonstrated that, to obtain the lowest possible propagation delay in our system, the best solution is to give the less priority to the background traffic, while warning messages must have the highest priority. In that case, about 70% of the nodes are informed in only 0:3 seconds. If we increment the priority of the normal messages, the system needs more time to inform 70% of the nodes (0:35 and 0:38 seconds). The worst case scenario arrives when all the messages (warning and normal) have the same priority, since the system needs 40% more time to inform 70% of the vehicles. The priority does not affect the percentage of blind nodes

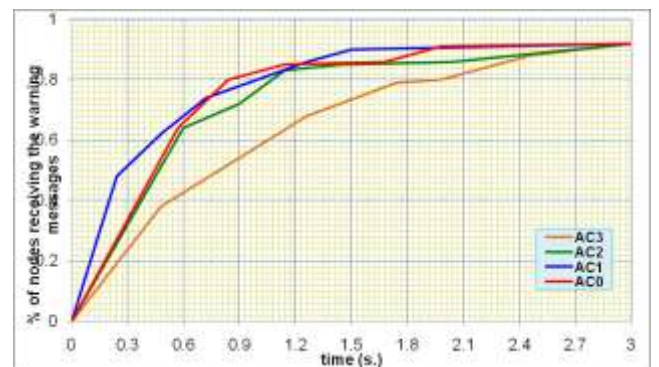

Figure 6. Propagation delay for different data rate with same priority

In this section we studied the impact of varying the periodicity of the messages sent in two different situations: first, when the priority of all the messages is the same and second, when the priority of the normal messages is lower than the priority of the warning messages. Figure 6 shows the propagation delay when varying the data rate considering that all the messages have the same priority.

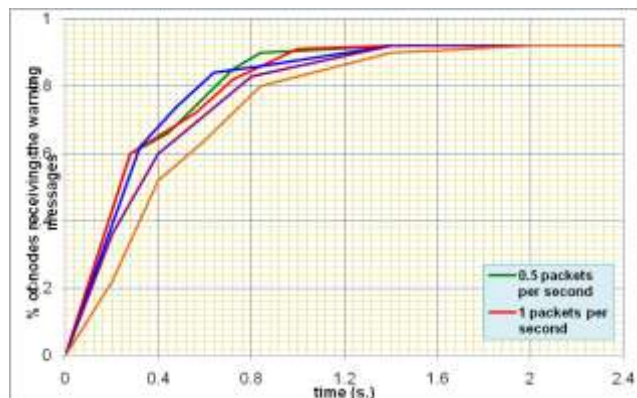

Figure 7. Propagation delay for different data rate with different priority

Figure 7 shows the propagation delay when varying the data rate considering that the priority of normal messages is lower than the priority of warning messages. As can be seen by comparing both figures, when the message priority differs the system's behavior is improved since it requires less time to inform 70% of the vehicles. In both cases, when the data rate increases, the system requires more time to inform the rest of vehicles. Therefore, to achieve optimum performance, we must find a trade-off between message generation intervals and system responsiveness. Besides, we must make sure that message priority is handled adequately to avoid that warning messages compete with other traffic

V CONCLUSION

In this paper we investigate the feasibility of deploying safety applications based on periodic message dissemination (PSM) through simulation study with safety requirements as our priority concern. Vehicles are supposed to issue these messages constantly to inform their neighboring

vehicles about their current status and use received messages for preventing possible unsafe situations on time. As reliability is the main concern in periodic message dissemination, a new metric called TGFD (Time Gap Following Distance) is defined which gives us more accurate benchmark for evaluating QoS in safety applications specifically. In this paper we presented a TGFD safe transmission interval for IEEE 802.11p-based VANET, and we made a performance analysis of inter-vehicle communication systems to improve traffic safety. As a conclusion, the current technology of IEEE 802.11p layer has still some challenges for VANET safety applications but this TGFD transmission interval can provide acceptable QoS to driver assistance safety applications.

REFERENCES

- Fadilah, S. I., & Shariff, A. R. M. (2014, January). A Time Gap Interval for Safe Following Distance (TGFD) in Avoiding Car Collision in Wireless Vehicular Networks (VANET) Environment. In *Intelligent Systems, Modelling and Simulation (ISMS), 2014 5th International Conference on* (pp. 683-689). IEEE.
- Joe, M. M., & Ramakrishnan, B. (2015). Review of vehicular ad hoc network communication models including WVANET (Web VANET) model and WVANET future research directions. *Wireless networks*, 1-18.
- Tong, Z., Lu, H., Haenggi, M., & Poellabauer, C. (2015). A stochastic geometry approach to the modelling of IEEE 802.11 p for vehicular ad hoc networks. *Submitted to IEEE Transactions on Vehicular Technology*.
- Tian, J., Treiber, M., Ma, S., Jia, B., & Zhang, W. (2015). Microscopic driving theory with oscillatory congested states: model and empirical verification. *Transportation Research Part B: Methodological*, 71, 138-157.
- Karumanchi, S., Squicciarini, A., & Lin, D. (2015). Privacy-aware access control for message exchange in vehicular ad hoc networks. *Telecommunication Systems*, 58(4), 349-361.
- Issariyakul, T., & Hossain, E. (2011). *Introduction to network simulator NS2*. Springer Science & Business Media.
- Torrent-Moreno, M., Jiang, D., & Hartenstein, H. (2004, October). Broadcast reception rates and effects of priority access in 802.11-based vehicular ad-hoc networks. In *Proceedings of the 1st ACM international workshop on Vehicular ad hoc networks* (pp. 10-18). ACM.
- Wisitpongphan, N., Tonguz, O., Parikh, J. S., Mudalige, P., Bai, F., & Sadekar, V. (2007). Broadcast storm mitigation techniques in vehicular ad hoc networks. *Wireless Communications, IEEE*, 14(6), 84-94.
- Mahajan, A., Potnis, N., Gopalan, K., & Wang, A. (2006, December). Urban mobility models for vanets. In *2nd IEEE International Workshop on Next Generation Wireless Networks* (Vol. 33).
- Benslimane, A. (2004). Optimized dissemination of alarm messages in vehicular ad-hoc networks (VANET). In *high speed networks and multimedia communications* (pp. 655-666). Springer Berlin Heidelberg.

Updating Information in Colored QR Code for Knowledge Sharing

Azizi Abas, Yuhanis Yusof and Farzana Kabir

University Utara Malaysia, Malaysia, yuhanis@uum.edu.my

ABSTRACT

Knowledge sharing is the process through which explicit or tacit knowledge is communicated to other individuals. Recently, the Quick Response (QR) Code which is a small size printed shape of black and white squares has been used in many domain as a storage medium. To date, it is a popular storage medium in the marketing domain. The code can easily be used to disseminate information about a product as it only requires a small printed area. The QR Code may contain various information such as URL, contact information, and application launching. However, the information stored in the QR Codes may require some modification or updating. Hence, this paper demonstrates a technique to update information stored in colored QR Code and regenerate the code using integrated techniques of compression, multiplexing and multilayered techniques (CoMM). The processes to regenerate an updated QR Code includes the decode and re-encode of the QR Code.

Keywords: QR Code; Colored QR Code, Data Storage.

I INTRODUCTION

The QR (Quick Response) Code is widely used in the application of marketing, retailing, advertising, production, tracking and others relating to product description (Kato & Tan, 2005; Kieseberg et al., 2010). It was categorized as two dimensional barcode because it can store more information compared with one dimensional barcode. It was developed by a company called Denso Corporation Japan in 1994 and officially recognized as an ISO international standard (ISO/IEC18004) (Falas & Kashani, 1994). The features of the QR Code covers the capability to encode high capacity data, printed out in a small size, robustness and the ability to be read in any direction of 360 degrees (Boob, Shinde, Rathod, & Gaikwad, 2014). Figure 1 below illustrates a sample of the QR Code.



Figure 1. The QR Code sample

Each of the QR Code module is represented as a single bit where a black square stores the value 1 and white square stores the value 0 (Nikolaos & Kiyoshi, 2010) (Grillo, Lentini, Querini, & Italiano, 2010). The type of QR Code is in black and white shape that able to encode and decode the characters with certain maximum capacity based on the type of characters. The type of characters used may as numeric (0 – 9) , alphanumeric (0-9, A-Z, a-z, space, \$, %, *, +, -, ., /, :), byte/binary (8-bit bytes) and kanji (Japanase symbols) to store data (Jagan, Akila, & Nasrin, 2015; Kieseberg et al., 2010). Table 1 shows the storage capacity of a QR Code orderd by type of characters. This maximum capacity is based on the QR Cod version 40 with error correction level L.

Table 1. The storage capacity in a QR Code.

Characters	Maximum Characters
Numeric	7089
Alphanumeric	4296
Binary	2953
Kanji/Kana	1817

The QR Code is in the form of a square shape with three corners of small square pattern used to determined the position of the QR Code during reading process at any angle position without giving incorrect output result (Jude J.L., 2015). To date, there are 40 versions of QR Code type; the smallest version is 1 which is contain 21 x 21 matrixes and the largest version is 40 with 177 x 177 matrixes. Each matrix will increase four modules from the previous version to next version (Sutheebanjard & Wichian, 2010).

The data capacity of a QR Code is determined by its error correction level. This error correcting level was developed as a recovery purpose. The recovery may needed when the QR Code contains miss reading, damage or others related. There are 4 type of recovery levels, which includes level L: (7% or less error), level M (15% or less error), level Q : (25% or less error) and level H : (30% or less error).

Since colored QR Code (Abas, Yusof, & Kabir, 2015) was introduced, there are some issues that requires attention. This includes the re-generation of QR Code when the stored information is obsolete or requires some modification. Base on the research above, if the colored QR Code needs to be manipulated, the first process involve is decode. It need to generate 24 black and white QR Codes. After the data was updated, it needs to re encode all the 24

black and white QR Codes to generate a colored QR Code. Such a process consumes large processing time as it needs to decode and re-encode the colored QR Code. This paper demonstrates the process of updating a colored QR Code and re-generate the code using the combination of multilayers (Pandya & Galiyawala, 2014; Pillai & Naresh, 2014), multiplexing (Vongpradhip, 2013) and compression (Victor, 2012) techniques. The proposed work involved text based with error correction level L.

According to Paulin and Suneson (2008), knowledge is the source and method that were obtained and at least it has been discussed. Meanwhile, knowledge sharing (Schwartz, 2006) is exchanging of knowledge between or among individuals, teams, unit and organizational. The propose works is to share among expertise on how to reduce time consume when the QR Code needs to decode and re-encode again.

II PROPOSED WORK

The colored QR Code was developed based on the abstract model as shown in Figure 2. The process to update information is divided into two levels, which is level 1 and level 2. Level 1 involves 24 black and white QR Codes while Level 2 includes the red, green and blue QR Codes. Each level contains decode and re-encode processes.

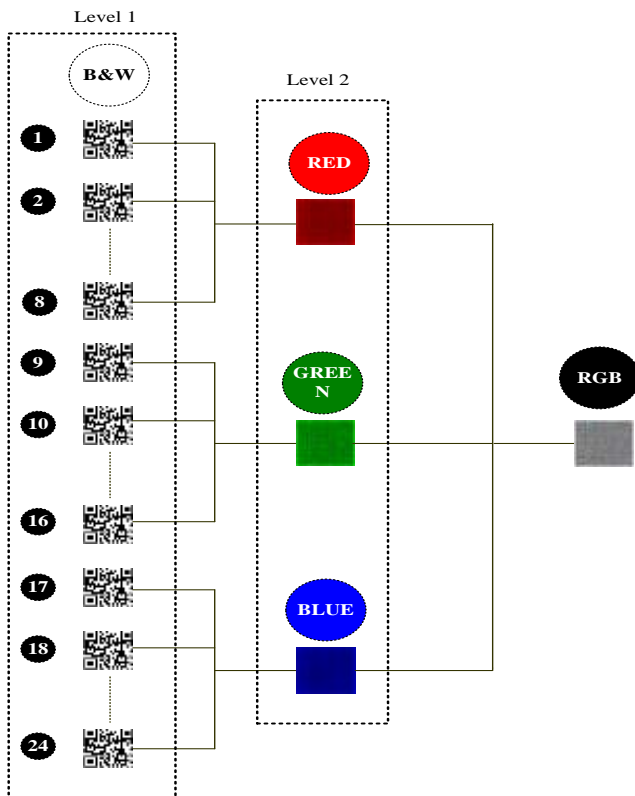

Figure 2. The colored QR Code development.

The proposed level 1 decode abstract model which is used to update the information in black and white QR Code is illustrated in Figure 3. This model will update the black and white QR Code information at location index 0. Meanwhile, for the re-encode abstract model is shown in Figure 4. This process will start updating text file information at location index 0.

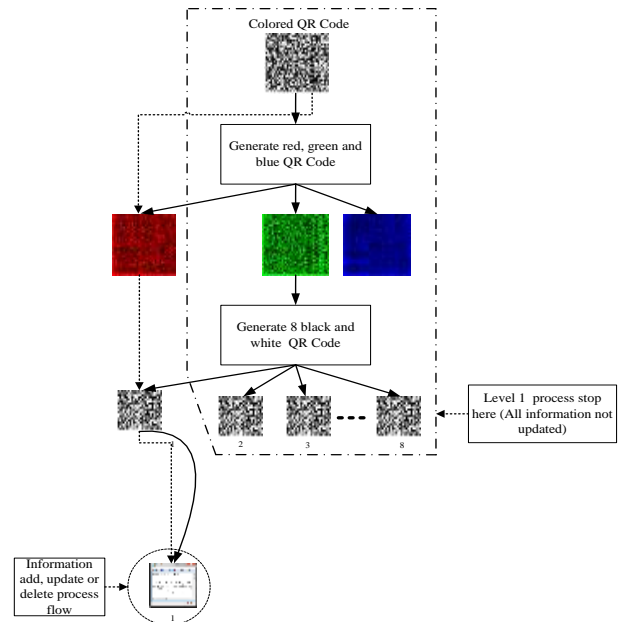

Figure 3. Level 1 decode abstract model

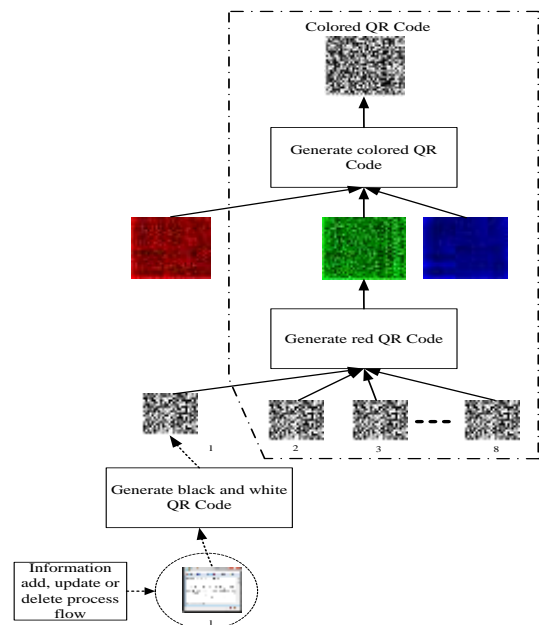

Figure 4. Level 1 re-encode abstract model

In addition, level 2 abstract model consists the operation to update the red, green and blue QR Code. This process will generate eight text files and the provider can manipulate a larger amount of

information. Figure 5 and 6 show the processes of decode and re-encode red color QR Code.

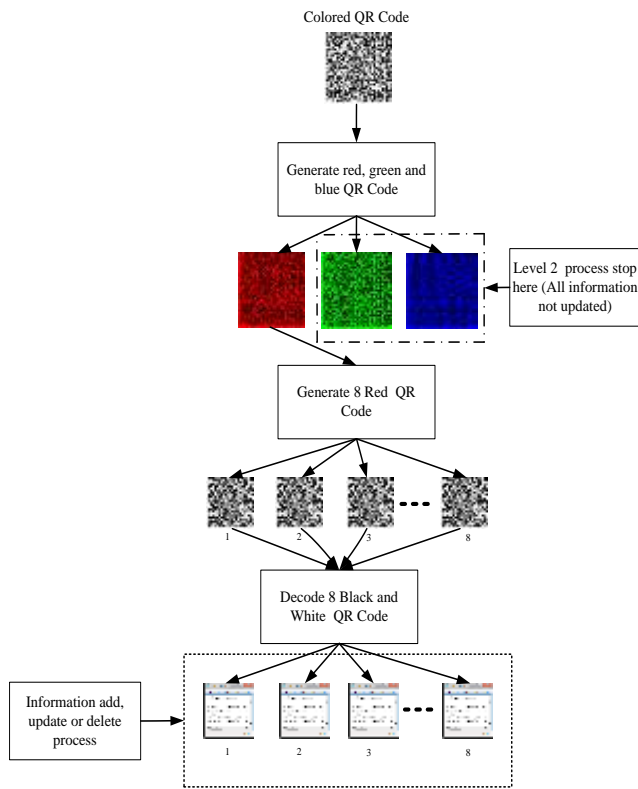

Figure 5. Level 2 decode abstract model

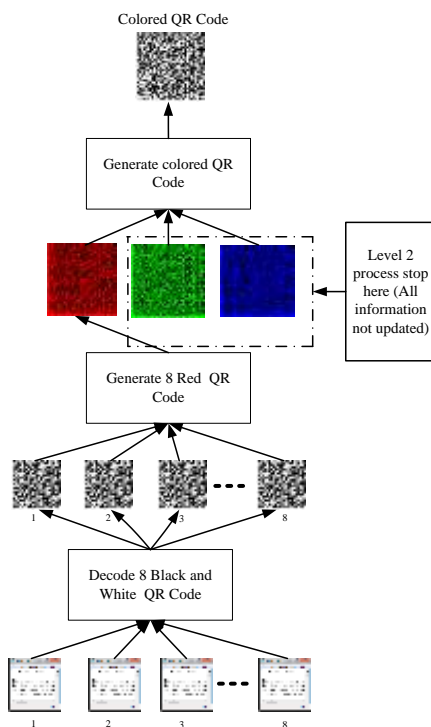

Figure 6. Level 2 re-encode abstract model

The input data is a compilation of text based on short stories which are stored in twenty four black and white QR Codes. The amount of the characters depends on the error correction level. The error

correction level L will be used in this experiment. Figure 7 shows a part of the employed input text which includes various types of characters such as numeric, alphabet and several symbols.

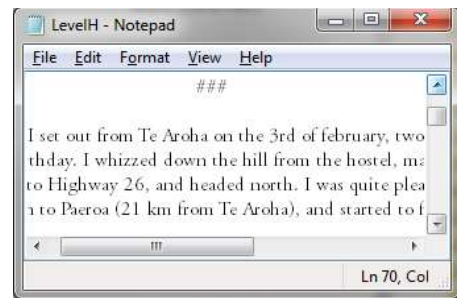

Figure 7. A part of input data text.

III EXPERIMENT

All of the experiments were performed using Java programming language and executed on a computer with processor specification of - Intel(R) Core(TM) i7-2670QM CPU @2.20GHz, RAM 8 Gigabytes and 64-bit Windows 7 Ultimate operating systems.

The utilized benchmark method is the QR Code of version 40. The maximum number of characters stored in each QR Code version 40 is shown in Table 1 while the size of the employed text file is 126 KB (129,512 bytes). Evaluation of the undertaken experiments is based on computational time.

IV RESULT

Several experiments were conducted and some figures and tables were tabulated as the results of these experiments. The process flow results for benchmark method (ie. QR Code version 40) and the proposed technique are shown in Figure 8, 9 and 10.

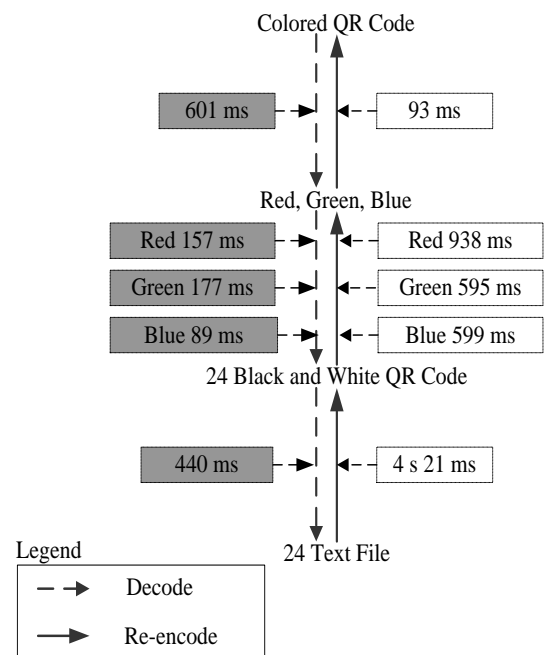

Figure 8. The process flow results for QR Code version 40

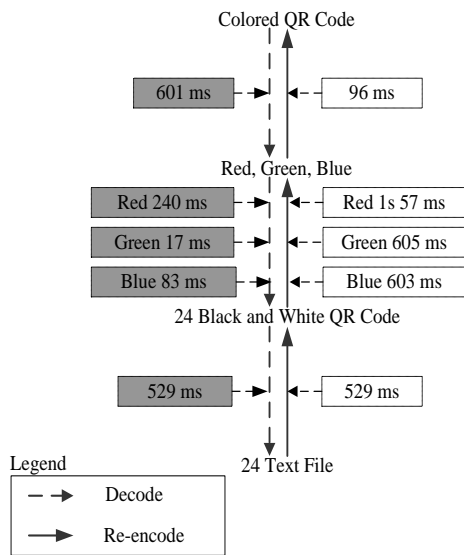

Figure 9. The process flow results for proposed technique level 1.

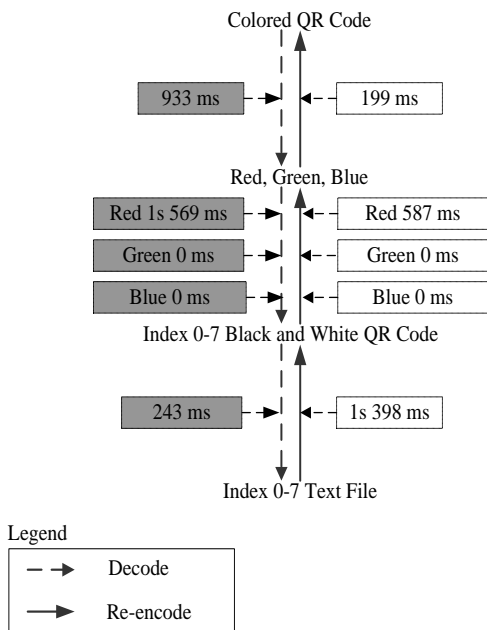

Figure 10. The process flow results for proposed technique level 2.

Based on Figures 8, 9 and 10, data were collected and tabulated in four tables ordered by level 1 and 2. The comparisons were made between each levels and the benchmark method. At the same time, each level is divided into decode and re-encode process. Table 2,3,4 and 5 shows the comparison between levels and resulted the different between them also separated within encode and decode processes.

Table 2. The comparison between benchmark and proposed technique in level 1 of decode process.

Level 1 (Decode)				
From	To	Benchmark	Proposed Level 1	Difference
Colored QR Code	Red Green, Blue	601 ms	978 ms	-377 ms
Red, Green, Blue QR Code	24 / Index 0 Black and White QR Code	423 ms	187 ms	236 ms
24 / Index 0 Black and White QR Code	24 / Index 0 File Text	440 ms	84 ms	356 ms
		1s	1s	
Total		464 ms	251 ms	231 ms

Table 3. The comparison between benchmark and proposed technique in level 1 of re-encode process.

Level 1 (Re-encode)				
From	To	Benchmark	Proposed Level 1	Difference
24 / Index 0 File Text	24 / Index 0 Black and White QR Code	4s 21 ms	231 ms	3s 790 ms
24 / Index 0 Black and White QR Code	Red, Green, Blue	2s 132 ms	621 ms	1s 511 ms
Red, Green, Blue QR Code	Colored QR Code	93 ms	195 ms	-102 ms
		6s 246 ms	1s 47m s	5s 199 ms
Total				

Table 4. The comparison between benchmark and proposed technique in level 2 of decode process.

Level 2 (Decode)				
From	To	Benchmark	Proposed Level 2	Difference
Colored QR Code	Red Green, Blue	601 ms	933 ms	-332 ms
Red, Green, Blue QR Code	24 / Index 0-7 Black and White QR Code	423 ms	1s 569 ms	-1s 146 ms
24 / Index 0-7 Black and White QR Code	24 / Index 0-7 File Text	440 ms	243 ms	197 ms
		1s	2s	-1s
Total		464 ms	745 ms	281 ms

Table 5. The comparison between benchmark and proposed technique in level 2 of re-encode process.

Level 2 (Re-encode)				
From	To	Benchmark	Proposed Level 2	Difference
24 / Index 0-7 File Text	24 / Index 0-7 Black and White QR Code	4s 21 ms	1s 398 ms	2s 623 ms
24 / Index 0-7 Black and White QR Code	Red, Green, Blue	2s 132 ms	587 ms	1s 545 ms
Red, Green, Blue QR Code	Colored QR Code	93 ms	199 ms	-106 ms
Total		6s 246 ms	2s 184 ms	4s 62ms s

From Table 3, the overall result in level 1 (decode) shown that proposed technique able to complete the task within 1 second 251 milliseconds compared with benchmark which is 1second 464 milliseconds. The different range between these techniques is 231 milliseconds. During the process to generate the red, green and blue QR Code, the time consume of the proposed technique process is slower than benchmark technique due to the task to collect information of pixels in the red QR Code is implemented. This process is not available in the benchmark technique. As a result, this will generate or consume the time processing.

When the decoding process in Table 3 is completed, the re-encode process will take over after update, delete or add information done. From Table 4, the total time consume has a large different range between benchmark and proposed technique which is 5 seconds 199 milliseconds. The benchmark technique has to generate 24 black and white QR Code, meanwhile, the proposed technique only needs to generate only one black and white QR Code. This is why the benchmark technique consumes more times compared with proposed technique. During the generation of colored QR Code, proposed technique consumes nearly twice of total time consume in benchmark technique. This is because the proposed technique has to collect pixel information in green and blue QR Code. From the data in Table 4 shows the time consume process has been conqueror by the proposed technique. The proposed technique took only 1 second 47 milliseconds to complete the process and the benchmark technique has completed in 6 seconds 246 milliseconds.

In level 2, the decode and re-encode process are executed in order to recover the red QR Code. Table 5 shows the same result of the decode process in level 1 at Table 3. The proposed technique took 933 milliseconds to complete the decode process from

colored QR Code to red, green and blue QR Code but the benchmark technique only took 601 milliseconds. For the next process, the proposed technique consumes 1 second 569 milliseconds, but benchmark process only took 423 milliseconds. The range difference is 1second 146 milliseconds. The reason is the red QR Code needs to separate the image file into a group of black and white QR Code which is starting from index 0 until 7. This process needs extra time to process. Overall, the time range difference between benchmark and proposed techniques is 1 second 281 milliseconds.

During the re-encode in level 2 at Table 6, the proposed technique has lead the time process with time range difference is 4 seconds 62 milliseconds. But in generating the colored QR Code, the benchmark QR Code has led to 106 milliseconds in time range difference. This result is same with level 1 re-encode processes and the reason is same with level 1 re-encode processes mention before.

From Table 6 below, it shows the information about overall Level 1 has time range difference with 5 seconds 430 milliseconds and Level 2 has time range difference with 2 seconds 781 milliseconds. From this result, the proposed techniques have a good performance compared with benchmark techniques.

Table 6. Level 1 and Level 2 time range difference.

		Benchmark	Proposed	Total Time (Level)	Total Time
Level 1	Decode	1s 464 ms	1s 251 ms	231 ms	5s 430ms
	Re-encode	6s 246 ms	1s 47ms	5s 199ms	
Level 2	Decode	1s 464 ms	2s 745 ms	-1s 281ms	2s 781ms
	Re-encode	6s 246 ms	2s 184ms	4s 62ms	

V CONCLUSION

In today's world that offers explosive information, various medium haven been used to store the required knowledge, information and data. And, this includes the use of QR Code which only requires a small size of printed area to store certain amount of data. This paper has demonstrate the use of a combination technique that allows the updating of information stored in a colored QR Code. As the undertaken experiment produces positive result, it is shown that updating information in QR Code can be realized using less computation time as compared to the existing method (i.e QR Code version 40). With such achievement, knowledge sharing via QR Code

can further be expanded. Information stored in the code can always be updated according to the providers needs.

In the future, there is a need to investigate its effectiveness on other error correction level such as M, Q and H. The reason is to see whether it is affecting the performance of the updated QR Code processes. Another possible direction is on concurrent processing. This will lead to studies in the area of performance capability, updated information and security in the QR Code.

ACKNOWLEDGMENT

The authors acknowledge the support given by Universiti Utara Malaysia.

REFERENCES

- Abas, A., Yusof, Y., & Kabir, F. (2015). Expanding the data capacity of QR codes using multiple compression algorithms and base64 encode/decode. *Jurnal Teknologi*, 1.
- Boob, A., Shinde, A., Rathod, D., & Gaikwad, A. (2014). Qr Code Based Mobile App and Business Process Integration. *International Journal of Multidisciplinary and Current Research*, 2(Sept and Oct 2014), 1014-1017.
- Falas, T., & Kashani, H. (1994). Two-Dimensional Bar-code Decoding with Camera-Equipped Mobile Phones. *Pervasive Computing and Communications Workshops, 2007. PerCom Workshops '07. Fifth Annual IEEE International Conference* (pp. 2-5).
- Grillo, A., Lentini, A., Querini, M., & Italiano, G. F. (2010). High Capacity Colored Two Dimensional Codes. *Proceedings of the International Multiconference on Computer Science and Information Technology* (Vol. 5, pp. 709-716).
- Jagan, A., Akila, P., & Nasrin, N. (2015). QR Code Based E-voting System Using an Android Smart Phones, *13(2)*, 263-267.
- Jude J.L., M. (2015). Audio Data As An Encoding for Color Quick Response Code (CQR) 3D Barcodes. *Journal of Theoretical and Applied Information Technology*, 73(2), 183-189.
- Kato, H., & Tan, K. T. (2005). 2D barcodes for mobile phones. *Proceeding Mobile Technology, Applications and Systems, 2005 2nd International Conference* (p. 8).
- Kieseberg, P., Leithner, M., Mulazzani, M., Munroe, L., Sinha, M., & Weippl, E. (2010). QR Code Security. *The 9th International Conference on Advances in Mobile Computing & Multimedia* (pp. 430-435).
- Nikolaos, T., & Kiyoshi, T. (2010). QR-Code Calibration for Mobile Augmented Reality Applications. *SIGGRAPH 2010* (p. 4503).
- Pandya, K. H., & Galiyawala, H. J. (2014). A Survey on QR Codes : in context of Research and Application. *International Journal of Emerging Technology and Advanced Engineering*, 4(3), 258-262.
- Paulin, D., & Suneson, K. (2008). Knowledge Transfer , Knowledge Sharing and Knowledge Barriers – Three Blurry Terms in KM, *10(1)*, 81-91.
- Pillai, P. N., & Naresh, K. (2014). Improving the Capacity of QR Code by Using Color Technique. *International Journal of Advanced Research in Electrical, Electronics and Instrumentation Engineering*, 3(7), 10561-10568. doi:10.15662/ijareeie.2014.0307025
- Schwartz, D. G. (2006). Encyclopedia of Knowledge Management. IGI Global. Retrieved from <http://library.books24x7.com/toc.asp?bookid=14700>.
- Sutheebanjard, P., & Wichian, P. (2010). QR-Code Generator. *2010 Eighth International Conference on ICT and Knowledge Engineering* (pp. 89-92).
- Victor, N. (2012). Enhancing the Data Capacity of QR Codes by Compressing the Data before Generation. *International Journal of Computer Applications (0975 –8887)*, 60(2), 17-21.
- Vongpradhip, S. (2013). Use Multiplexing to Increase Information in QR Code. *The 8th International Conference on Computer Science & Education (ICCSE 2013)* (pp. 361-364).

The Digital Divide and Behavioral Intention of ICT adoption for Health Information Among People in Rural Communities

Nopparat Meeplat¹, and Zulkhairi Md Dahalin²

¹Nakhon Si Thammarat Rajabhat University, Thailand, dewmemory@hotmail.com

²Universiti Utara Malaysia, Malaysia, zul@uum.edu.my

ABSTRACT

The purpose of this paper was to assess the basic knowledge of ICT among people in rural area. To determine the association between behavioral intention of ICT adoption and health information among people in rural communities. The study used a survey method to collect data from people in rural area. The results found that most people known about ICT and used mobile phone to communicate between each other. In addition, the hypothesis showed that there are 42 percent of people intent to used ICT for searching health information. The level of significance showed the p-value <.05.

Keywords: digital divide, health information, rural communities.

I INTRODUCTION

The world is rapidly changing in the field of technology. ICT is now a part of most peoples' lives. It has changed lifestyles, communication, sources of competitive advantage, and opportunities for economic and social development (Opesade, 2011). There is a debate going on about the Internet if there is a digital divide between users and non-users; those who can access the internet and those who cannot (Kent, 2012). In addition, the digital divide is important to study and solve the problems of how gaps in ICT among countries have changed (Doong & Ho, 2012).

According to OECD (2001), the digital divide means the gap between people who have the opportunity to use computers and technology and those whose opportunities are limited or non-existent because of low incomes and/or through living in a rural area. Ruth (2012) states a digital divide is unfolding between those with access to a high speed capacity and quality to access information technology (IT) and those with lower speed and capacity and quality. Abdelfattah (2013), notes that the digital divide means the difference in opportunities between those in an urban environment and those in rural areas.

ICT is key to solving the problem of the digital divide in healthcare because ICT can help people to learn and use the technology to search for information about healthcare (Connolly, 2013). If people learn more

about healthcare, they can care for themselves better (Dzenowagis, 2011).

Knowledge of health is important for people to learn about and prevent diseases. When people have the ability to access information about healthcare, they are more likely to engage in preventative behavior.

There are several health information studies available, for instance, the Kaiser Family Foundation (2011) states that web-based content, including the development of health information websites be done. The health information websites offer better understanding with regard to health care. It is for this reason that surfing websites for information about health can assist in health care needs.

Allison and Trauth (2013) report that health information depends on the socio-economic situation, the infrastructure of ICT and the ability of people to use ICT for searching out health information online. This study suggests that knowledge of health information can be beneficial to patients to get a better understanding and care for themselves.

Wang et al. (2011) point out the differences in Internet access among urban areas and rural areas. In addition, there was observed to be a medical limitation in the rural areas because of the geography and the lack of opportunity to access the Internet. Therefore, the subjects would not know about news and information about healthcare found online.

Amy (2011) examines the differences in the health information seeking behavior of rural, suburban and urban Internet users. There is a difference in the information seeking behavior of the people in rural areas who use more books and other printed material than their urban and suburban counterparts. According to George et al., (2013), the knowledge gap that influences the effectiveness of telehealth technologies, produces confusion and fear potentially affecting a patient's confidence in quality of care and limiting their disease management ability. At that juncture the knowledge gap can be the digital divide of patients to care for themselves.

Information and Communication Technology (ICT) is a conveyance to bridge the gap of equality between urban and rural healthcare centers and to resolve the problems of the health sector (Ruxwana, Herselman, & Conradie, 2010). Knowledge of ICT is important

for people in rural areas when they wish to use ICT for searching out information on healthcare. However, they should receive training in how to use and access ICT.

Palvalin et al. (2013) analyze the impact of ICT on knowledge work productivity and found that ICT can be used to eliminate non-value adding tasks or to make them efficient. ICT can also improve employee welfare, ICT and knowledge work productivity by explaining how the impacts of ICT can be analyzed in a given empirical context.

Mohamed et al. (2010) state that knowledge of ICT could be a sustainable development and the understanding of ICT could be a valuable guidance of knowledge management practice in supporting sustainable development. Lee and Kelkar (2013) note knowledge of ICT can be used to support knowledge management in organizations. Knowledge of ICT is useful in organizations and the organization must be cognizant of the leadership style adopted by their knowledge to create value. Toro and Joshi (2013) report the essence of ICT, which is to open new avenues in knowledge and play an important role for sharing, exchanging and disseminating knowledge and ICT in higher education.

The objective of this paper as following.

1. To assess the knowledge of ICT from people in rural communities.
2. To determine the association between behavioral intention of ICT adoption and health information among people in rural communities.

II RESEARCH METHOD

This study employed survey research using a quantitative approach to collect the data from people in rural areas in the south of Thailand. The questionnaire was verified by three experts. One expert was from the psychology program from Walailak University and two other experts were from the computer education program and innovation development program of Nakhon Si Thammarat Rajabhat University, respectively. In addition, the instrument was designed based on a Theory of Plan Behavior (TPB), Technology acceptance model (TAM), UTAUT models and existing literature review about basic understanding of ICT, knowledge of ICT for health information and behavioral intention. The internal consistency (Cronbach's alpha) reliabilities of the variables after composite scores have been calculated. Cronbach's alpha was computed for each variable to test the internal consistency and reliability of three variables used in this study. According to Hair et al., a Cronbach's alpha value of more than 0.6 should be obtained for an item

to be reliable and can be accepted. There three variables are basic knowledge of ICT is independent variable the internal consistency results of this variable, comprising 10 items and present the Cronbach's alpha value is .751. the behavior intention comprising ten items and shows the Cronbach's alpha value is .726. the dependent variable is ICT adoption for health information comprising ten items and shows the Cronbach's alpha value is .747.

A. Sample Size and Sampling Techniques

This study used multi-stage and selected the sample group from eight provinces in the south of Thailand these being: Songkhla, Phatthalung, Satun, Krabi, Pang Nga, Trang, Nakhon Si Thammarat and Surat Thani. The sample group came from people living in rural areas from eight provinces above and divided into 32 sub-districts. The sample size and sampling techniques were conducted using the Taro Yamane formula for social and behavioral researches (Cochran, 1963).

The following steps were employed in choosing the respondents and sampling techniques.

B. Procedure and Data Collection

This study used a quantitative research method to collect data from people from rural areas in the south of Thailand. The study used the multi-stage method to design and select the sample population. The sample population live in eight provinces: Songkhla, Phatthalung, Satun, Krabi, Pang Nga, Trang, Nakhon Si Thammarat and Surat Thani. Ten research assistants visited each province and distributed 100 questionnaires for each province. The research assistants visited the district and sub districts of each province and collected data from people in these areas. They explained the purpose for collecting data if they did not understand the questions. The respondents returned the questionnaires in approximately 30 minutes. In this process, the study was concerned about ethical considerations, thus the detail of the data would be confidential and the assistants had to respect people in every place that they visited. A total of 550 questionnaires were distributed and 87 percent completed.

III DATA ANALYSIS

A process of data analysis was used to test the data based on the research questions and original hypotheses. The statistical analyses were conducted to test the two parts of the data. The first part was used to test for regression analysis consisting of simple regression analysis and multiple regression analysis. The second part was used to test for hierarchical analysis for testing the moderator variables.

A. Descriptive Analysis

The descriptive analysis describes the general statistical description of variables in the study such as demography of the respondents, the means, standard deviation, minimums and maximums for the independent and dependent variables. The data was collected from the sample of the respondents in rural communities of eight provinces of Thailand. The data collected was answered by all the respondents.

Most of the participants (232) are female (58.00%) and 168 are male (42%). Age range between 15-24 years at 28 percent, between 25-34 years 29 percent. The age range between 35-49 years is 28.2 percent and those aged over 50 years is 14.8 percent.

The education level can be described as follows. 16.5 percent graduated from primary school, while 13 percent graduated from secondary school. 30.8 percent graduated from high school, and 30.2 percent graduated with a bachelor degree. 3.5 percent graduated at master degree and 6 percent education unknown.

The respondents' occupation is as follows. 20 percent are farmers and 16.8 percent are officers. While 10.5 of the respondents are officials and 7 percent are fishermen. In addition 5.8 percent are in business, while 40 percent of the respondents have other occupations such as gardeners, house keepers and those with no occupation.

With regard to income 34 percent earn a salary between 10,000 to 19,999 baht per month. While 29.7 percent have a salary between 5,000 to 9,999 baht and those respondents with a salary less than 5,000 are 22.5 percent. On the other hand, the respondents earning between 20,000 to 29,999 baths are 7.8 percent and 3 percent have an income between 30,000 to 39,999 baht. Only 3 percent of the respondents earn more than 40,000 per month.

B. Results of the study

This study used a questionnaire to assess the basic knowledge of ICT and used a survey method to collect data from 481 people in rural areas of eight provinces. The purpose of this assessment was to learn the basic understanding of using ICT from people such as using ICT, knowing about ICT and the frequencies of using ICT. The descriptive analysis can be described as table 1.

Table 1 Basic Understanding of ICT

Items Description	Most answers	Percentage
1. The meaning of ICT	Yes	91.7
2. Kinds of ICT that people know about	Mobile phone	85.2

3. Do people have ICT equipment?	Yes	96.9
4. Type of ICT that people have	Mobile phone	91.5
5. Type of ICT that people use	Mobile phone	77.5
6. Amount of time used	<1 hour	49.7
7. Purpose of using ICT	Searching information	62
8. Application	Facebook	49.3
9. Channel for accessing health information	Facebook	54.9
10. Where ICT is used	House	78

Table 1 shows the basic knowledge of ICT from people in rural communities and can be explained as follows. 91.7% know the meaning of ICT, while the kind of ICT that people used are mobile phones at 85.2 %. Most people access ICT via a mobile phone at 91.5%, and always using a mobile phone at 77.5%. People using ICT on mobile phone for searching information is at 62%. The application program that they used is Facebook (49.3%). The channel used for ICT to search information through Facebook at 54.9% and they always use at home 78%. Therefore, most people know about ICT and always use a mobile phone for searching health information from their home.

C. Hypotheses testing

This hypothesis is about behavior intention in health information and ICT adoption for health information. The study used a simple regression, to test the hypotheses.

Hypothesis 1: Behavioral intention in health information will have a significant positive influence on usage.

Table 2 simple regression analysis examining predictors of behavior intention in health information will have a significant positive influence on usage

Variable	R	R ²	SEE	T	Sig	Durbin watson
Constant						
Behavior Intention	.648	.420	.633	18.61	.000	1.698

The result from Table 2 shows the behavior intention in health information would have a significant positive influence on usage of ICT adoption. The simple regression coefficient (R) was .648 and multiply R (R²) was .420. The value of t was 18.61 (p<.05).Durbin-Watson being 1.698 indicated that there was no errors in the variables. This hypothesis can

be explained that the behavioral intention of people had a positive influence on using ICT for health information as 42%.

Table 3 simple regression analysis examining predictors of behavioral intention in health information will have a significant positive influence on usage

Model	β	Beta	T	Sig	ViF
(Constant)	1.695	.096	17.59	.000	
ICT adoption for health information	.603	.032	.648	.000	1

Table 3 shows the coefficient of predictors in the best fit model and collinearity statistics. With the tolerance statistics and VIF equal to 1.00 and the B and Beta coefficients (B=.603, Beta = .648) were stable in the ICT adoption for health information

IV DISCUSSION

The results of this study show that the basic knowledge of ICT among people in the rural area. The basic knowledge of ICT is important for them to access health information. This study shows the basic knowledge of ICT as following. Most people in rural area know the meaning of ICT and they use mobile phone to communicate between friends.

Almost people have ICT equipment such mobile phone because the price of mobile phone is lower than computer or laptop. In the rural area living cost each important, since some people graduated as primary school and they low income. In addition, amount of time used is less than one hour because of work. They use ICT as mobile phone to search information and use Facebook for chatting and sometime used Facebook to search about health information because it is easy for them to learn and now Facebook is the most famous in Thailand. However, people used ICT at their home.

People have positive influence to adopt ICT for searching health information because it quite easy and it is basic for learning ICT by themselves. However, people in rural area confront the problem of Internet broadband and sometime they cannot connect to the Internet. Therefore, mobile phone is a channel for them to learn and use ICT. People accepted to use ICT for health information because Thai government have promoted to people about how to care themselves.

V CONCLUSION

This study emphasizes on the basic knowledge of ICT for health information in the south of Thailand. This paper used a survey questionnaire to collect data from people in rural area from eight provinces in the south of Thailand. Most people in each province live out of municipality and far the urban about 100 kilometer. The results show most people know about ICT and use ICT as mobile phone more than using

computer or laptop because the prices of mobile is inexpensive. Then they can use and learn about information and news from mobile phone. However, the problems about the Internet are not cover all areas then the government should provide the network for all area of Thailand. Then they can learn more about health information and use ICT for searching information about health information to aware them from the disease and have good health like in Thailand call smart health in Thailand.

REFERENCES

- Abdelfattah, B. M. T. (2013). *Essays on the digital divide*. (3610094), The University of Texas at El Paso, Ann Arbor. Retrieved from <http://eserv.uum.edu.my/docview/1500560924?accountid=42599> ProQuest Dissertations & Theses Global database.
- Allison Janeice, M., & Trauth, E. M. (2013). Socio-economic influences on health information searching in the USA: the case of diabetes. *Information Technology & People*, 26(4), 324-346. doi:<http://dx.doi.org/10.1108/ITP-09-2012-0098>
- Amy, H. (2011). The Rural Digital Divide: Exploring Differences in the Health Information Seeking Behaviors of Internet Users. *Franklin Business & Law Journal*(2), 65-77.
- Anonymous. (2011). The Digital Divide and Access to Health Information Online. *Medical Benefits*, 28(12), 3.
- Cochran, W. G. (1963). *Sampling techniques*. 2nd edition: John Wiley & Sons.
- Connolly, K. K. (2013). *The digital divide and health outcomes: A teleretinal imaging study*. (3572418), University of Hawai'i at Manoa, Ann Arbor. Retrieved from <http://eserv.uum.edu.my/docview/1430292816?accountid=42599> ProQuest Dissertations & Theses Global database.
- Doong, S. H., & Ho, S.-C. (2012). The impact of ICT development on the global digital divide. *Electronic Commerce Research and Applications*, 11(5), 518-533. doi:<http://dx.doi.org/10.1016/j.elerap.2012.02.002>
- Dzenowagis, J. (2011). BRIDGING THE DIGITAL DIVIDE in Health. *UN Chronicle*, 48(3), 27-29.
- George, S., Moran, E., Fish, A., & Ogunyemi, L. (2013). Understanding the digital divide in the clinical setting: the technology knowledge gap experienced by US safety net patients during teleretinal screening. *Studies In Health Technology And Informatics*, 192, 946-946.
- Hair, J. F. (2010). *Multivariate data analysis*. Pearson College Division.
- Kent, B. L. (2012). *The Digital Divide and Technology Acceptance*. (3529159), TUI University, Ann Arbor. Retrieved from <http://eserv.uum.edu.my/docview/1039149344?accountid=42599> ProQuest Dissertations & Theses Global database.
- Lee, C. S., & Kelkar, R. S. (2013). ICT and knowledge management: perspectives from the SECI model. *The Electronic Library*, 31(2), 226-243. doi:doi:10.1108/02640471311312401
- Mohamed, M., Murray, A., & Mohamed, M. (2010). The role of information and communication technology (ICT) in mobilization of sustainable development knowledge: a quantitative evaluation. *Journal of Knowledge Management*, 14(5), 744-758. doi:doi:10.1108/13673271011074872
- OECD (Ed.) (2001). *UNDERSTANDING THE DIGITAL DIVIDE*. 75775 Paris Cedex 16, France: Organisation for economic co-operation and development.
- Opesade, A. O. (2011). Strategic, value-based ICT investment as a key factor in bridging the digital divide. *Information Development*, 27(2), 100-108. doi:10.1177/0266666911401707
- Palvalin, M., Lönnqvist, A., & Vuolle, M. (2013). Analysing the impacts of ICT on knowledge work productivity. *Journal of Knowledge Management*, 17(4), 545-557. doi:doi:10.1108/JKM-03-2013-0113
- Ruth, S. (2012). Is There a Digital Divide? Check the Numbers. *Internet Computing, IEEE*, 16(4), 80-83. doi:10.1109/MIC.2012.83

- Ruxwana, N. L., Herselman, M. E., & Conradie, D. (2010). ICT applications as e-health solutions in rural healthcare in the Eastern Cape Province of South Africa. *Health information management journal*, 39(1), 17.
- Samsuddin, S. F., Omar, S. Z., Samah, B. A., & Bolong, J. (2016). Potential Impingement Factors of Information and Communication Technology Usage at Rural Libraries in Malaysia. *Mediterranean Journal of Social Sciences*, 7(2), 360.
- Toro, U., & Joshi, M. J. (2013). A review of Literature on Knowledge Management using ICT in Higher Education. *International Journal of Computer Technology and Applications*, 4(1), 62.
- Wang, J.-Y., Bennett, K., & Probst, J. (2011). Subdividing the digital divide: differences in internet access and use among rural residents with medical limitations. *Journal Of Medical Internet Research*, 13(1), e25-e25. doi:10.2196/jmir.1534

Analysis of Contents on Youth Media Participation in Marginalised Communities

Norshuhada Shiratuddin, and Zainatul Shuhaida Abd Rahman

Universiti Utara Malaysia, Malaysia, shuhada@uum.edu.my, kembalikurnia@yahoo.com

ABSTRACT

Future research on youth participation and media should be designed for the perceived importance of the role of the media and its impact on youth. Therefore, a study was conducted to determine the issues that affect youth lives as voiced by them. The youth participation was tracked for six months through contents submitted to a web platform in the form of web tv, web radio and web journalism. This paper presents the issues in politics, social and economic that are seen as major concerns to the youth in marginalised communities in Malaysia. The highest viewed submissions are identified as the main issues.

Keywords: Participation, marginalised communities, youth, social media

I. INTRODUCTION

The electronic media is a platform of social interaction involving a branch of a new communications environment resulting from applying the new medium of communication technology or hybrid technology. Media communication carries information between the source and the receiver in order to facilitate communication. Social media involves several key elements that comprise a set of web pages that run multiple processes including collaboration, sharing and democratization of Internet users. Moreover, social media communication approach consists of a number of methods such as internet forums, social blogs, micro-blogging, wikis, podcasts, pictures, videos, ratings and social bookmarking user votes (Rothschild, 2011). Besides that, the Youth Development Research Institute Malaysia in 2011 indicates the highest Internet usage of use per day which are 37% is by the youth. Nevertheless, youth participation in national development in the political process and civic engagement is still relatively low (Golombek, 2002). Therefore, various efforts were undertaken to ensure that the various types of media are positively used as tools to better facilitate and encourage their participation in society.

To address these issues, a study was conducted to determine the concerns as voiced by the youth on

the issues that affect their lives and communities in the marginalized communities. Those are considered marginalized based on their household income and the areas they live in. The youth participation was tracked through the use of web tv, web radio and web journalism. The selection of the three types of medium is intended to maximise youth creativity and innovation.

II. YOUTH AND MEDIA

Framing the issues of youth in the media, specifically social media has a major impact on society. Karen Brooks of The Dallas Morning News said the power of the Internet is very powerful when a video, photographs and slogans spread to thousands or hundreds of thousands of these home pages and profiles. Therefore, everything that is served by youth in Malaysia in the media represents the position of the image of youth itself. According to the Youth Development Research Institute Malaysia through the media penetrance study found a total of 82.1 percentage of youths surf the internet and 83.3 percentage of them use computers further to this, a total of 96.6 percentage of youth share information via their mobile phones. This clearly shows a close relationship between media and youth.

Pan and Kosicki (1993) have been using qualitative method as the most appropriate method to analyze the contents by the youth published in the web media. Analysis is done from two points of view, namely that the concept of psychological frame of mind as interpersonal problems and the sociological concept of how youth see the frame of the social construction environment. Similarly, Entmen (1993) model, put more emphasis on text analysis and solutions through text.

There are two strategies in the media framing analysis that is through verbal and non verbal to see the image, issues, opinions and sign language made verbally. Tuchman (1980) for instance stated that the use of certain symbols or language can define a narrative format and specific meaning. Visual interpretation too can convey thoughts and images about reality brought up by the youth.

Youth active involvement with the media is expected to fill their spare time and fulfill their activities from their social conduct disorders. Not

only that, close involvement with social media can also be guided where opinion and conscience can be heard. Habermas (1996) argued that, in order to form a civil society that can function better, it should be assisted by the media. It is agreed by Checkoway (2003) the youth involvement with the media is still relatively backward either in practice or research subjects. In line with this opinion, Montgomery (2000), Vromen and Collin, (2010) agree that future research on youth participation and media should be designed for the perceived importance of the role of the media and its impact on youth in particular to ensure that marginalised youth can represent the community and be heard.

III. METHODOLOGY AND FINDINGS

The study was conducted in settlement areas, estates, villages, flats and public housing from five states in Malaysia, where 405 youths between the ages of 15-25 years were involved. Youth were introduced to a web platform named the Youth for Malaysia (Y4M) (<http://www.youth4malaysia.com/>). This platform is dedicated for the youth to share with and learn from each other regarding issues affecting them. In other words, this platform allows them to upload and voice their opinions regarding issues around them. Their works can be published in three forms of web broadcasting, namely Web

TV which covers videos form (refer to Figure 1), Web Radio covers audio forms, and Web Journalism covers their voice and opinion in the form of articles.

The platform was monitored for 6 months from Oct 2015 until March 2016. Based on the Table 1, the analysis shows 116 audio recordings were received from the youth. From the analysis, 21 youth sent audio recordings relating to the political issues. For social issues (25 people) and economic issues (70 people).

In the political context, most of the youth wish to have better freedom of expression and be able to provide views on voting process. Whereas, in the context of the social, the majority of them touched the topic of arts and entertainment (traditional musical art). Furthermore, in the context of economy, they raised the financial management issues. To them, the economic problems arising from the depreciation of the ringgit, rising prices have caused them to be more responsible in managing the financial affairs of the purchase. They also expect more online business skills and business management be exposed to them.



Figure 1: Y4M platform

Table 1. Analysis of participation through web audio

POLITICS	No of participation	Recorded views	SOCIAL	No of participation	Recorded views	ECONOMIC	No of participation	Recorded views
Freedom of speech (voting process, election)	9	490	Hobbies (appreciating the traditional food, nvolve in festivals)	9	73	Economic issues (GST) - political management conflicts cause the ringgits drop	7	64
Political stability (the importance of new generation roles)	8	168	Heath (health care, good nutrition practices)	3	62	Business (online business)	17	273
Current issues (cybercrime law)	4	543	Beauty (knowledge in skincare)	3	174	Occupation (unemployment- the burdent of debt)	2	8
			Arts and entertainment (involve in traditional music)	9	401	Quality and skill in financial management (is required)	44	711
			Crime and social problems (snatch, free sexual, misbehavior, smoking)	1	125			

Table 2 shows an overall analysis of the 139 articles received during the period. The highest number of submission is for the social theme with 71 articles. Most of the articles (30 submissions and viewed by 4,814 viewers) relate to the arts and entertainment (music, creative writing) and crime and social (issues of abandoned babies, corruption, dengue, bullying, illegal racing). Meanwhile, submission for political theme is 40. The youth write articles about the current issues (GST, pollution, and rising petrol prices). For

economic themes, there were 28 submissions. There are a number of issues raised by the youth; the drop of the ringgit and quality of life/income, smoking, live in unity, homelessness, and bankruptcy. Their expectations are majorly on their future and towards a better quality of life and economic stability factors. In fact, they also showed interest in serving the country because of their love for the country.

Table 2. Analysis of participation through web journalism

POLITICS	No of participation	Recorded views	SOCIAL	No of participation	Recorded views	ECONOMIC	No of participation	Recorded views
Freedom of speech (social problem, racist, elections, news dissemination)	4	1,103	Hobby (writing poetry, short stories)	4	1,070	Current issues on economic (ringgit drops)	14	3,842
Political stability (loves homeland, youth involvement)	2	2,82	Health (smoking, chemicals, strokes)	12	2,393	Business (online fraud, political power)	3	498
Urban and rural gap (lack of public transport, living standard gaps)	8	1,300	Beauty (appreciate the beauty)	2	163	Occupation (unemployment, agricultural interests, lack of skills)	4	656
Racist issues (repression of Rohingya, dispute the Malays right, racial harmony)	8	1,455	Arts and entertainment (music, creative writing interests)	30	4,814	Financial life quality (smoking issue, unity, homelessness issue, bankruptcy)	7	3385
Current Issues (corruption, disparity of socio-economic between urban and rural, GST, pollution, rising petrol prices)	18	3,250	Crime and social problems (dumping babies issue, corruption, dengue, bullying, illegal racing)	23	3,701			

Based on the Table 3, most submission of web TV is the social theme with 62 TV programmes. While total submission for politics is 8 and economic is 1. In the context of social, topics covered are on music, acting, and misuse of Whatsapp, theft, promiscuity, alcohol consumption, and baby dumping. Crime problems to the youth can lead to deterioration in education, gengstrisma, sex and smoking. In addition, the examples of quality of life that youth would like are a clean

and healthy environment, a strong religious faith, corruption and living in unity. In the political context, the youth were again concern on the issue of freedom of speech. In addition, they are aware of how the viral on the politically incorrect statements could cause chaos and riots. There was one video submission relating to business where they express their opinion on choosing a product either beauty or health products carefully.

Table 3. Analysis of participation through web TV

POLITICS	No of participation	Recorded views	SOCIAL	No of participation	Recorded views	ECONOMIC	No of participation	Recorded views
Freedom of speech (want freedom of speech)	4	602	Hobby (learning foreign languages, traveling, singing)	9	1,235	Commerce (youth to have knowledge of marketing)	1	178
Political stability (Chinese youths learn dialect of Malay)	1	158	Sports (exercise method)	5	319			
Racial issue (conflict in certain countries, uniting nation through festivals)	2	413	Health (smoking problem, obesity)	6	575			
Current issue (youth attitudes about viral political issues and effects to the country)	1	202	Beauty (beware of direct sale products)	3	208			
			Arts and entertainment (music, acting, misuse of whatsapp)	23	3,102			
			Crime and social (theft, promiscuity, alcohol, baby dumping)	16	2,178			

IV. CONCLUSION

This study explores how the youth, particularly those living in marginalised communities, use technology of web tv, web radio and web journalism to voice their views. Their views are then framed to relate to how

youth participation can contribute to the national agenda. An ealier focus group studies also successfully identified parts of the concerned issues (Norshuhada, et al., 2015) and they were presented in thematic analysis diagrams. However, the study was undertaken

prior to the actual youth participation and a lengthy period of observation.

The majority of the youth concerns under the politics theme are corruption, disparity of socio-economic between urban and rural in terms of GST, pollution, rising petrol prices, ethnic relations, racial harmony, nation security, freedom of speech, political harmony and respect, youth voices and political awareness. Under the social theme, most are talking about music, acting, misuse of Whatsapp, theft, promiscuity, alcohol, baby dumping, dengue, bullying, and illegal racing. The youth are much interested in online business (a similar finding was also obtained in Shahizan, et al., 2015), current issues on economic such as drop of Ringgit, and skill in financial management.

The youth are the future citizens of the world and the media should have the responsibility to ensure that youth are protected in terms of intellectual and emotional (Nadchatram, 2007). The youth of this marginalised if given the opportunity, knowledge and skills with the use of the media, they would be able to figure out a way to pass time and participate in the nation building.

ACKNOWLEDGEMENT

We wish to thank the Malaysia Ministry of Higher Education for the LRGS grants given to undertake this study.

REFERENCES

- Checkoway, B. (2011). What is Youth Participation, *Children and Youth Services Review*, 33 (2), 340-345.
- Checkoway, B. And Richards-Schuster, K. (2003). Youth Participation in Community, *Evaluation Research, American Journal of Evaluation*, 24(1), 21-23.
- Entman, R. M. & Rojecki, A. (1993). Freezing Out the Public: Elite and Media Framing of the U.S.
- Golombek, S. (2002) *What Works in Youth Participation: Case Studies from Around the World*. International Youth Foundation.
- Habermas, J. (1987). *The theory of communicative action, Vol. 2, Lifeworld and system: A critique of functionalist reason*. Boston: Beacon Press.
- Montgomery, K. (2000). Youth and Digital Media: a policy research agenda, *Journal of Adolescent Health*, 27(2), 61-68.
- Norshuhada Shiratuddin, Shahizan Hassan, Mohd Khairie Ahmad & Nurul Labanihuda Abd Rahman (2015). Youth and Media Participation: Key Issues of Concern, *International Journal of Management and Applied Science*, 2(2), 29-32.
- Nadchatram, I. (2007). *Forum: Media's Role in Shaping Malaysia's Youth*. Kuala Lumpur: Unicef.
- Pan, Z. & Kosicki, G. M. (1993). Framing Analysis: An Approach to News Discourse. *Political Communication*, 10(1), 55-75.
- Rothschild, P. (2011). Social media use in sports and entertainment venues, *International Journal of Event and Festival Management* 2(2),139-150.
- Shahizan Hassan, Norshuhada Shiratuddin & Sobihatun Nur Ab Salam (2015). Social Media as Persuasive Technology for business in Malaysia. *International Journal of Electronic Business Research*, 11(2), 18-39.
- Tuchman, G. (1978). *Making News: A Study in the Construction of Reality*. New York: The Free Press.
- Vromen, A. & Collin, P. (2010). Everyday Youth participation: Contrasting view from Australian policymakers and young people, *YOUNG*, 18(1), 97-112.

Engaging Youth in Decision-Making Process via New Media: A Case of Rural and Urban Youth in Marginalized Communities in Malaysia

Shahizan Hassan, Norshuhada Shiratuddin, and Zainatul Shuhaida Abdull Rahman

Universiti Utara Malaysia, Malaysia, shahizan@uum.edu.my

ABSTRACT

This paper presents the outcome of a study, which investigates the way in which youth in marginalized communities utilize new media to participate in the decision making process. It aims to identify issues commonly raised by the rural and urban youth. Data gathering for this study involves three phases – conducting focus group discussions with 51 participants from five states in Malaysia, developing new media portal for youth, and organising five intervention programmes involving 393 rural and urban youth of marginalized communities in Malaysia. The findings show that the youth are more interested to voice out issues related to social aspects, particularly issues related to quality of living. Other issues are freedom of speech and rising cost of living. However, there are also some differences in terms of the issues raised by the rural and urban participants, which are discussed at length in this paper. This study highlights the need for the government to take into account various issues raised by the youth in the decision and policy-making processes.

Keywords: new media, social media, youth inclusion, media use, marginalised communities

I INTRODUCTION

The marginalization issue could have an impact on the level of youth participation and engagement in public decision-making (Hourcade, Bullock-Rest, & Schelhowe, 2010). However, the emergence of new media and affordable mobile phones and computers has potentials of minimizing this problem. Many youth are now able to own the technology. In the context of Malaysia, there is an exponential growth of mobile phone ownership. In 2014, it was reported that there were 43,248,000 mobile phone subscriptions with a penetration rate of 144.2 per 100 inhabitants (SKMM, 2015). Out of these, 50 per cent are smart phone users. This shows that the gap in terms of access to technology among Malaysian citizens is small. Taking this into account, mobile phone can be a good platform for youth in marginalised communities to participate in the policy and decision making process. With the emergence of new media and popularity of mobile phones, youths have better

opportunities to exercise their rights and engage in the civil society.

In relation to this, a study was conducted to investigate the way in which new media is utilised by youth in marginalised communities to participate in the policy and decision making process. This study focuses on two main issues – potential use of new media for youth to participate in civil society and key issues of concerns among rural and urban youth in the marginalised communities.

This paper starts with a discussion on the youth and media participation, and the motivation and justification of the study, followed by the method used to achieve the objectives. Next is the presentation of the findings which include the key issues raised by the youth and the differences of issues of concerns between youth in the rural and urban areas. The paper will then conclude with a discussion on the outcome of the study.

II YOUTH AND MEDIA PARTICIPATION

Age is the key component in defining youth. However, researchers have different views regarding the age range that can define youth. Henceforth, in the context of this research, the age range defined by the United Nation is used. The United Nation defines youth as those between the ages of 15 to 24 (UN Factsheet, 2013a). Youth at this age range make half of the world's population. The UN report in 2013 shows that about 225 million youth, or 20% of all youth in the developing world, are "idle" – not in education, employment or training (UN Factsheet, 2013b). Their participation in nation building, political process, and civic engagement are still low (UNDP, 2012; Golombek, 2002).

Consequently, the youth are demanding equality to exercise their full rights as citizens to participate, engage, and voice opinions on issues affecting the nation (Cohen & Kahne, 2012). They want to be heard and to be consulted in the process of developing the national agendas particularly those related to education, politics and economic issues. In lieu of this, there is a need to study the extent of which new media can play a role in enhancing the participation of youth in nation building.

III DATA GATHERING

Five focus group discussions involving 51 youths were conducted separately in five states in Malaysia - Kelantan, Kedah, Selangor, Johor and Sabah. These states were selected to represent five different regions in Malaysia namely Northern region (Kedah), Central region (Selangor), Southern region (Johor), Eastern region (Kelantan), and Sabah/Sarawak. The main focus of the discussions was to ascertain the participants' opinion regarding the potentials of new media usage among youth and to identify key issues affecting youth in the marginalized communities. A set of guidelines was developed for the focus group to ensure that the objectives were achieved. Video recording and note taking were used to collect the data, after which thematic data analysis was conducted to analyse the qualitative data.

Based on the analysis, 15 issues (four economy, three politics and eight social) were identified. This finding is used as a basis for developing a new media portal named Youth4Malaysia. The portal provides three new media tools namely WebTV, WebRadio, and Web journalism for youth to participate and voice their opinions in the issues and areas, which are previously identified via the focus group discussions.

Once the portal was completed, five intervention programmes were conducted involving 393 rural and urban youth of marginalized communities in several geographical locations in Malaysia (Northern, central, southern, eastern, and Sabah and Sarawak). These intervention programmes are trainings being provided by the researchers to instill the basic skills of using the three new media tools on the participating youth. Once they know how to utilise these tools, the participants developed their own contents for the WebTV, WebRadio and Web journalism (i.e. articles). The materials were then uploaded onto the portal's server for assessment and review purposes. In addition, all users of the portal were encouraged to view and comment on the content.

The content uploaded by the participants was then analysed to identify the key issues raised by them. Feedback and comments by viewers of the content were also analysed. In addition, the researchers also analysed whether there are any differences in the issues raised by youth in the marginalized communities in the urban and rural areas. This finding may be imperative especially for the government and policy makers to determine the relevancy and effectiveness of the youth development programmes.

IV KEY ISSUES OF CONCERNS

Table 1 shows a list of key issues identified by the youth during the focus group discussions. Social category has the highest number of issues (eight

issues), which include hobbies, sports, health, beauty, arts and entertainment, crimes, racial issues, current social issues, and quality of living. This is followed by the economy category, which are hot economic issues, business, jobs, and cost of living. Politics has the lowest number of issues (only three), which are – current political issues affecting the nation, economic stability, and the gaps between rural and urban.

Table 1. Issues of concerns identified by Youth

NO	Politics	Social	Economy
1	Current political issues	Hobbies	Hot economic issues
2	Economic stability	Sports	Business
3	Urban and rural gap	Health and Beauty	Jobs
4		Arts and Entertainment	Cost of Living
5		Crimes	
6		Racial issues	
7		Current social issues	
8		Quality of living	

Participation in WebTV

Table 2 shows WebTV submissions by category and by rural and urban youth in marginalized communities. There are a total of 71 WebTV clips being submitted, out of which 64 (90 percent) are under social category. This means that the participating youth in both rural and urban area are more interested in social aspect rather than politics and economy. Surprisingly, majority of the clips are related to quality of living issues (40 percent by rural and 33 percent by urban youth). This clearly indicates that the youth especially those who live in rural area are expressing their views on the need by the government to improve quality of living especially among the youth in Malaysia. In addition, the youth especially those who live in urban area (19 percent of the submission), are also expressing their concerns regarding the rising crime rate. This is another important area, which should be taken care of by the government. The urban youth are also submitting considerably high number of clips on issue related to hobbies, health and beauty.

Table 2. WebTV submissions for politics, social, and economy category by issues and youth group

Category	Issues	Qty	Rural	Urban
Politics	Current political issues	1	1	0
	Political stability	2	1	1
	Freedom of speech	3	2	1
	<i>Sub Total</i>	6	4	2
Social	Living quality	23	9	14
	Crime issues	11	3	8
	Hobbies	9	2	7
	Health and beauty	6	1	5
	Current social issues	6	3	3
	Arts and Entertainment	4	2	2
	Racial issues	4	2	2
	Sports	1	0	1
	<i>Sub Total</i>	64	22	42
Economy	Hot issues	0	0	0
	Business	1	1	0
	Jobs	0	0	0
	Cost of Living	0	0	0
	<i>Sub Total</i>	1	1	-
Total		71	27	44

Participation in Web Journalism

Table 3 presents submissions of Web journalism materials by the participants. Surprisingly, the portal received more submissions in this category (139 contributions) compared to WebTV (71 contributions) and Web Radio (28 contributions). There are some interesting findings from the analysis. For politics category, more than 50 percent of the articles are related to freedom of speech. This indicates that the participants in both rural and urban areas perceive that youth should be allowed more freedom to express their opinion in the political issues particularly those, which have an impact on youth. Nonetheless, participants from rural area are also expecting the government to maintain political stability in the country. This is evident when 19.2 percent of the submitted articles by this youth group discussed political stability issues.

In social category, there is a clear difference between the two youth groups on the issue of living quality. Participants from urban area seem to pay more attention on this issue where 42.6 percent of the 54

articles submitted describes the need for the government to upgrade the living quality of the youth in the poor family in the urban area. In line with this, the youth in the rural area are concerned with the issue of rising cost of living. In the economics category, 80 percent of the submitted articles by this youth group reveal the hardship they are suffering due to the rising cost of living in the rural area.

Table 3. Web Journalism submissions for politics, social, economy category by issues and youth groups

Category	Issues	Qty	Rural	Urban
Politics	Current political issues	12	7	5
	Political stability	6	5	1
	Freedom of speech	22	14	8
	<i>Sub total</i>	40	26	14
Social	Living quality	27	4	23
	Crime issues	7	2	5
	Hobbies	11	5	6
	Health and beauty	5	1	4
	Current social issues	9	1	8
	Arts and Entertainment	11	5	6
	Racial issues	1		1
	Sports	1		1
	<i>Sub total</i>	72	18	54
Economy	Hot issues	12	1	11
	Business	4	0	4
	Jobs	1	0	1
	Cost of living	10	4	6
	<i>Sub total</i>	27	5	22
Total		139	49	90

Based on the analysis of user views, articles in the economy category which are related to quality of living, receives the highest views/reads compared to the other two categories. This indicates the importance of this issue among the participants and the users (readers) of the portal.

Participation in WebRadio

Table 4 presents the statistics on WebRadio submissions. Most of the submissions were made by the urban participants (i.e. 71.4%). Again, the trend shows that the participants are more interested in the social and economy issues rather than politics. Urban youth in particular, submitted their radio clips on social issues related to hobbies, health and beauty, and Arts and Entertainment. None of the rural participants submitted their clips in this category.

Similar number of submissions was made by the rural participants for the economy issues (i.e. hot economy issues, business, jobs, and cost of living). A notable difference to the statistics of WebTV was found whereby urban youth are more concerned regarding freedom of speech and the rural youth are more interested in political stability.

Despite low number of submissions in the political category, these WebRadio clips received commendable views/ hits. In fact, two of the clips submitted in this category are the top two mostly viewed among the portal users/ visitors. The highest is the clip on current political issues (543 views), followed by the clip on freedom of speech (490 views). This shows that despite the low interest among the participants to submit their works on political issues, the users and visitors of the portal are more interested to follow on these issues. Unfortunately, further analysis on the portal users or visitors cannot be conducted due to limited information on their backgrounds.

Table 4. Web Radio submissions for politics, social, economy category by issues and youth category

Category	Issues	Qty	Rural	Urban
Politics	Current political issues	2	1	1
	Political stability	1	1	0
	Freedom of speech	1	0	1
	<i>Sub total</i>	4	2	2
Social	Living quality	-	-	-
	Crime issues	-	-	-
	Hobbies	1	0	1
	Health and beauty	2	0	2
	Current social issues	0	0	0
	Arts and Entertainment	1	0	1
	Racial issues	0	0	0
	Sports	0	0	0
	<i>Sub total</i>	4	0	4
Economy	Hot issues	2	1	1
	Business	1	0	1
	Jobs	1	0	1
	Cost of living	2	1	1

	<i>Sub total</i>	6	2	4
	Total	14	4	10

V DISCUSSIONS AND CONCLUSIONS

Youth exclusion in the decision making process is a global issue which has long been debated. This is more apparent among the youth group who are living in the marginalized communities. The outcome of this study indicates that new media can indeed be a good platform for the youth to participate and voice out their opinions regarding various issues affecting their welfare. This is in line with several other studies such as Hopkins (2010) and Hourcade, Bullock-Rest, and Schelhowe (2010), which also highlight the positive impact of new technology on youth engagement in politics, social and economy. This study also reveals the fact that when attempting to tackle issues involving youth, the government and relevant authorities need to differentiate between youth in the urban and rural areas. It appears that issues of concerns for these two groups may differ due to different living conditions, neighbourhood and lifestyle.

This study provides evidence on the importance of new media as platform to bridge the gap between the government and relevant authorities with the youth in the marginalized communities. Consequently, it can minimize the youth exclusion problem, which as it is commonly known, can hinder the nation's progress.

REFERENCES

- Cohen, J. C., & Kahne, J. (2012) *Participatory politics: New media and youth political action*. Oakland, CA: YPPSP
- Hopkins, L. (2010). Youth Worx: Increasing youth participation through media production. *Journal of Sociology*, 47(2), 181–197. DOI:10.1177/1440783310386827
- Hourcade, Bullock-Rest, Schelhowe (2010). Digital technologies and marginalized youth. *IDC 2010*, June 9–12, Barcelona, Spain.
- UN Factsheet (2013a). Definition of youth. Retrieved from <http://www.un.org/esa/socdev/documents/youth/fact-sheets/youth-definition.pdf>
- UN Factsheet (2013b). Youth and education. Retrieved from <http://www.un.org/esa/socdev/documents/youth/fact-sheets/youth-education.pdf>
- UNDP. (2012). *UNDP Annual Report: The sustainable future we want*. UNDP.
- Golombek, S. (2002) *What Works in Youth Participation: Case Studies from Around the World*. International Youth Foundation.
- SKMM (2015). *Handphone users survey 2014*. SKMM. Retrieved from <http://www.skmm.gov.my/skmmgovmy/media/General/pdf/Hand-Phone-User2014.pdf>

A Review of Three Models for Knowledge Management in Healthcare Organizations

Zaid A. Sabeeh¹, SMFD Syed Mustapha², and Roshayu Mohamad¹

¹Asia e University, Malaysia, {zaid.aljarah; roshayu.mohamad }@gmail.com

²Taif University, Kingdom of Saudi Arabia, smfdsm@gmail.com

ABSTRACT

The paper discusses previous models constructed for managing knowledge in the context of healthcare organizations. These previous studies are focused on suggesting implementations for the knowledge management's initiatives that are aimed at optimizing the healthcare services. Three models had been thoroughly reviewed and attention has been addressed to explain the constructs of these models. These constructs include factors, entities and elements involved in the creation, storing, transfer and use of the knowledge within a healthcare organization. Subsequently, a gap analysis has been applied to shed light on the shortcomings of each model and how the proposed framework will overcome them. These shortcomings were synthesized in six themes, these themes were realized from the inclusion of all constructs and factors addressed by the three studied model. The development of the proposed framework (HKMF) is still under study in an ongoing research that aims at optimizing the medical knowledge management within a selected healthcare organization. Further refinements and improvements will be applied to the proposed framework and its elements after the data collection and analysis are completed. The paper concludes with recommendations for future research works and efforts intended enhancing the management of knowledge within healthcare organizations.

Keywords: Knowledge management, healthcare organization, medical knowledge, knowledge management model.

I INTRODUCTION

Knowledge management (KM) implementations in the healthcare sector depend on the technological tools to manage creating, storing, sharing, and utilizing knowledge. The continuous improvement to the healthcare services requires adequate implementations to overcome the obstacles occurring in this sector. Systems used in managing healthcare services are considered to be much compounded with internal and external entities, that it involves several partners operating in diverse domains that need to be coordinated in order to deliver quality healthcare service to patients (Platis, Reklitis and Zimeras, 2015).

Those entities might involve general practitioners, specialized physicians, nurses, medical assistants, clerks, and general workers. Depending on the size of operations in the healthcare facilities, these systems can include administrators, managers in finance, human resources, IT technicians, pharmaceutical suppliers, healthcare insurance providers, education institutes and research communities. Based on the interactions between those partners, the amount of knowledge is massive while all of knowledge details created by any of those partners are necessary for a successful healthcare service delivery.

II KM IMPLEMENTATIONS IN HEALTHCARE

KM techniques in healthcare sector has been connected to an exceptionally expansive range of organizational exercises intended to oversee, trade and make or improve knowledge resources inside of a healthcare organization (Araujo et al. 2015; Gattnar et al. 2015). Key improvements in Healthcare Knowledge Management (hereinafter HKM) have been focused mostly on productivity issues and given less attention on the creation of knowledge and methods to manage this knowledge. Studies in the field of KM in health services had shown the existing policies and practices have not been effective in actualizing adequate methods in delivering quality healthcare service and meeting the medical organizations' objectives (Rexhepi, 2015; Matshwane, 2015). Some healthcare organization have taken the approach of viewing these practices as a pro table vital resource, and knowledge sharing between representatives seems to be originated from formal and informal knowledge sources. One of the most vital elements for effective HKM policies is to encourage the workers to join the knowledge sharing activities inside of the healthcare organization (Ahlan and Ahmad, 2015). Some of these organizations have taken the path of utilization workers' knowledge through procedures and enhanced them through innovation that is used to enhance the quality, proficiency, intensity of the healthcare services. These procedures are aimed at urging the medical staff to share knowledge that has impact on improving the performance and productivity (Khammarnia et al, 2014). On the other hand, HKM has similarly included

the collaboration of social components that depends greatly on informal interactions among the medical staff, which usually involves implicit knowledge sharing. The successful application of HKM systems has been connected to internal social practices of the employee communities (Knauth and Meinerz, 2015). The execution of HKM system like-wise requires a comprehension of the knowledge management process to be carried out by suitable experts and managerial staff. In healthcare centers, explicit knowledge, i.e. documented knowledge, is accessible in patient's records, exploration reports, and industry databases. Whereas, implicit knowledge is found in the brains of very specific professionals, for example, neurosurgeons, pediatricians, pathologists and cardiologists, nurses and medical assistants. Sometimes this type of inferred knowledge surfaces when effective knowledge sharing takes place. This type of communication happens in the gathering among medical professional's communities in the conferences, workshops and specialized informal trainings (Tahamtan and Sedghi, 2014).

III PREVIOUS MODELS OF KM IN HEALTHCARE

In order to understand the existing state of knowledge management in healthcare organizations, it is essential to review similar efforts made by other researchers. The study of literature showed the three models which directly focused on the management of knowledge in healthcare centers. The components of these models will be discussed and will aid in guiding the primary data collection and in realizing initial starting points for the proposed framework to be developed. The first model, Knowledge Management Conceptualization in Healthcare, was developed by the School of Health Information Science, University of Victoria, US (Lau, 2004). The second model, Total Knowledge Management in healthcare (TKMh), was developed by Knowledge Management for Healthcare research subgroup in Coventry University, UK (Bali et al. 2009). While the third model, Knowledge Management Infrastructure in Healthcare, developed by, School of Business IT and Logistics, RMIT University, Australia (Wickramasinghe, 2010).

A. Knowledge Management Conceptualization in Healthcare

This framework addresses the initial conceptualization of Knowledge Management for the healthcare centers. First, knowledge is defined in this model "as information combined with experience, context, interpretation, and reflections; the knowledge source may be explicit or tacit depending on where it is located". Attention is paid to the social interactions

that require a continuous communication, coordination and collaboration among policymakers, practitioners, and researchers to be effective and sustainable as shown in Figure 1, Knowledge Management Conceptualization in Healthcare.

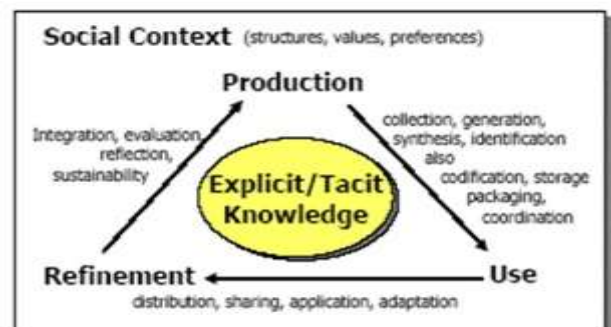

Figure 1. Knowledge Management Conceptualization in Healthcare (Lau, 2004)

i. Knowledge Production

Knowledge production addresses various methods in knowledge creation in the healthcare industry. Knowledge production in healthcare has sub-concepts which are Collection, Generation, Synthesis, Identification, Codification, Storage, Packing and Coordination.

ii. Knowledge Use

Knowledge use addresses the methods followed by policymakers and practitioners in the healthcare organization to transfer knowledge to the targeted communities. Knowledge use should be customized and made suitable to communities' cultural settings, values and differences. The sub-concepts for knowledge use are Distribution, Sharing, Application and Adaptation.

iii. Knowledge Refinement

Knowledge refinement refers to "ways in which policy, evidence, and experience as knowledge sources are institutionalized with organizations over time as part of routine practices in a taken-for-granted fashion". Knowledge refinement has four sub-concepts which are Integration, Evaluation, Reflection and Sustainability.

iv. Social Context

This evolving environment of healthcare organization requires the attention to social context that influence the production, use and refinement of knowledge in the healthcare organization. The social context construct has three sub-concepts which are Structures, Values and Preferences.

B. Total Knowledge Management in healthcare TKMh

The Total Knowledge Management in healthcare (TKMh) refers to the Knowledge management techniques in healthcare that are oriented towards main idea of knowledge-sharing in a tacit to tacit environment. This model (Bali et al., 2009) addresses the importance of a human-oriented approach to be followed, as shown in Figure 2, when executing knowledge management initiatives in healthcare. The layout of this model can be viewed as set of phases directed at implementing health care knowledge management.

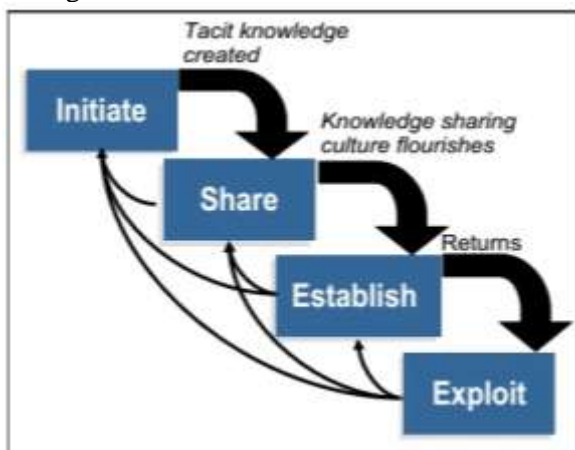

Figure 2. Total Knowledge Management in healthcare (TKMh) (Bali et al., 2009)

There are four phases in this model, the first phase is Initiate which focuses on improving the required abilities for the healthcare workers and activities of those workers to create tacit knowledge that is embedded in the daily routines. The second phase is Share which prepares the appropriate domain for the healthcare personnel to have plans for knowledge sharing and focus on tacit-to-tacit knowledge transfers. The third phase is Establish which refers to the sharing of knowledge within network structure in the healthcare Organization's communities. The fourth and final phase is Exploit which indicates the iteration loop and urges the healthcare organization to make use of the returns of the established culture for the ultimate objective of delivering better healthcare services. These set of phases work in an iterative feedback cycle to improve its earlier stages and to strengthen the quality of each phase until each phase has attained its highest efficiency.

C. Knowledge Management Infrastructure in Healthcare KMIH

This model is made of social and technical tools and techniques, including hardware and software that should be established "so that knowledge can be

created from any new events or activities on a continual basis" (Wickramasinghe, 2010). The Knowledge Management Infrastructure (KMIH) depicted in Figure 3 presents the five essential elements (organizational memory, human asset infrastructure, knowledge transfer network, business intelligence infrastructure and infrastructure for collaboration). These five elements are essential for effective knowledge management initiatives.

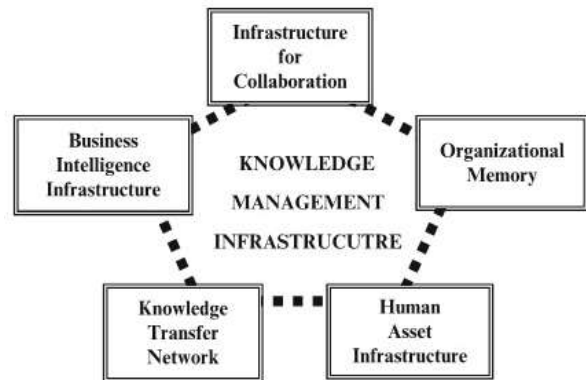

Figure 3. KM Infrastructure in Healthcare (Wickramasinghe, 2010)

There are five components of the KMIH model the first one (Infrastructure for Collaboration) represents a fundamental part in ensuring competitive advantage and improving customer satisfaction. The second component (Organizational Memory) refers to the retention of the health organization's "know-how" which is recorded in documents or in its people. The third component (Human Asset Infrastructure) indicates the willingness of workers to take part in knowledge sharing activities. The fourth component (Knowledge Transfer Network) addresses the channels and means for dissemination of knowledge in the healthcare organization. The effective transfer of knowledge depends greatly on the availability and the quality of such networks. The fifth and final components (Business Intelligence Infrastructure) expresses the fact that healthcare organizations usually gather sizable amount of data and the need to analyzing those data in order to effectively utilize the knowledge exist in the organization. This model has taken a different approach comparing with the other two models discussed in the previous two sections. The focus here is mostly on improving the processes of knowledge management by focusing on adequate infrastructures in the aforementioned areas. Additionally, it paid attention to the information systems and the importance of utilizing the knowledge bases in these organizations in order to provide quality care service to the patients. This framework has discussed the vital role of establishing adequate business intelligence infrastructure, this attention to business intelligence has been detected in recent studies in the field of managing knowledge within

healthcare organizations (Baeshen 2014; Brooks, El-Gayar and Sarnikar, 2015; Safwan, Meredith and Burstein, 2016).

IV GAP ANALYSIS FOR THE STUDIED MODELS

The reviewed KM healthcare models reflected several gaps and themes that have not been fully addressed. The role of gap analysis is to report the ideal state and the current state of a system of a model (Kahle-Piasecki and Doles, 2015). Several researches had recommended the application of gap analysis when dealing with knowledge management systems in healthcare organizations (Cudney et al. 2015; Abbate et al. 2014). The previous knowledge management models in healthcare organizations have shown different level of itemization for the elements involved in the management of knowledge. Six major themes were excerpted from the previous three models: acquiring of knowledge, people dealing with knowledge, knowledge-sharing culture, knowledge repository, ICT support and top management reinforcement. Gap analysis for the three studied models will consider these themes to shed light on the shortcomings of each model and how the proposed framework will overcome them as shown below:

A. Shortcomings of Knowledge Management Conceptualization in Healthcare

1. Acquiring of Knowledge: It has discussed the production of knowledge however; it has not provided what are the entities involved in acquiring knowledge in a healthcare organization. Additionally, this model did not explain the connection between the knowledge acquisition and the sustainability of healthcare organizations which is essential for a successful management of knowledge in organizations (White, 2015).

2. People Dealing with knowledge: This model did not address the role of employee dealing with knowledge in the healthcare organization. It has merely mentioned the general notion of social context. Explaining 'who does what' in the healthcare organization was an absent part in this model, this part is considered to be of a high value to the knowledge management in healthcare according to Ratnapalan and Uleryk (2014).

3. Knowledge-Sharing Culture: the importance of an organizational culture that promotes sharing of knowledge has not been fully addressed in this model. It has been stated that inadequate knowledge sharing within healthcare organization can cause medical error and inefficient delivery of medical services (Tabrizi and Morgan, 2014).

4. Knowledge Repository: this model has discussed the static sense of storing and retrieving knowledge in storage devices. The lack for proper structure for the knowledge stored in a healthcare organization can hinder the productivity of the organization due to the fact that medical personnel base their decision making on the stored knowledge regarding a specific patient or medical procedure (Ling et al. 2014).

5. ICT Support: There is an absence of clear explanation for the role of ICT solutions in supporting the knowledge management initiatives within the healthcare organization. Consequently, this model missed out the facilities which can be provided by technological advances (Ramli and Ali, 2015).

6. Top Management Reinforcement: The role of top management in the knowledge management activities was not presented in this model. The main concepts and sub-concepts has not reported any involvement of the of the organization's leadership, an involvement that is required for smooth knowledge sharing within the healthcare organization (Kim, 2016).

B. Shortcomings of Total Knowledge Management in Healthcare TKMh

1. Acquiring of Knowledge: the model referred to creation of knowledge in a pure technical aspect, there's no indication of the organizational practices involved in the creation and acquiring of healthcare knowledge, these practices are focal in the acquisition of healthcare knowledge according to (Olkiewicz, 2015). Furthermore, the TKMh model had solely mentioned the initiation process of the tacit knowledge with in an AI algorithm, no clarifications were stated to describe how the knowledge acquisition is being carried out.

2. People Dealing with Knowledge: due to the technicality of the TKMh, the model has neither pointed out the role of the healthcare personnel in the knowledge creation nor the knowledge sharing within the healthcare organization. The model has overlooked the pivotal role of people in organization (Simon, 2016) while focusing entirely on the functionality of the AI algorithm.

3. Knowledge-Sharing Culture: the term 'sharing' was addressed in the pure sense of transferring data

between several set of applications (Bali et al. 2009, p.25), there is an absence of the holistic view of knowledge sharing within an organizational culture that promotes such sharing activities. This model did not pay attention to the importance of organizational traditions and settings that advocate the knowledge sharing throughout the healthcare organization which is key for successful knowledge management (Rashid and Ahmad, 2016).

4. Knowledge Repository: the iterative phases of TKMh (initiate, share, establish and exploit) were based mostly on the technological aspect of knowledge. The location and the process of storing were neither described in this model, the description of these essential information were overlooked on both organizational and operational viewpoints.

5. ICT Support: the model has explained the technical aspect of automating the process of predicating useful knowledge. This model's main focus was on providing a computer-based solution for prediction of knowledge, it has not specified the role of strategic sense of ICT support throughout organization's segments. The essential role of ICT support in the success of knowledge management initiatives (Limaye et al. 2015) was not indicated in this model.

6. Top Management Reinforcement: the intervention of healthcare organization's top management was not presented in this model. No details were stated of how top management can support the knowledge management initiatives within the healthcare organization. The support and encouragement of top management is necessary for the success of knowledge management initiatives according (Buta, 2015).

C. Shortcomings of Knowledge Management Infrastructure in Healthcare KMIH

1. Acquiring of Knowledge: although there is an indication of the importance of "organizational memory" the model has not mentioned how the knowledge acquisition is being performed and what are the roles and entities involved in the process of acquiring healthcare knowledge. Additionally, KMIH has not explained how the learning activities are taking place among the medical and non-medical staff within the healthcare organization. These learning activities are deemed to be immensely central in the forming of organizational knowledge in healthcare organization (Stary, 2016).

2. People Dealing with Knowledge: The model expressed the role of "Human assets" in the sense of people with special skills and experiences in creating

better businesses (Wickramasinghe, 2010). However, the model has not demonstrated how the people in the organization are being affected by the knowledge and how they are affecting the creation and transfer of knowledge across various levels employees in the healthcare organization. Specifying how people are affecting healthcare knowledge is essential for smooth application of knowledge management initiatives (Alhalhouli, Hassan, and Der, 2014).

3. Knowledge- Sharing Culture: the model has briefly discussed the transfer of knowledge through the transfer networks, nonetheless there is no clear illustration of the importance of an organizational culture that fosters knowledge sharing among the healthcare organization staff. Clarifying the need for the knowledge-sharing culture is crucial for the sustainability of healthcare organization (Peralta and Saldanha, 2014).

4. Knowledge Repository: this model has pointed out the accumulation of knowledge and the existence for knowledge repository in KM infrastructure (Wickramasinghe, 2010, p.25). Yet the model has not provided clarifications of how this repository is being formed and updated as well as the method of which people are dealing with this repository in the healthcare organization. Knowledge management initiatives are expected to be effective when there is adequate knowledge repository that stores the healthcare organizational knowledge (Badimo and Buckley, 2014).

5. ICT Support : the model has not clearly demonstrated the use of ICT-based solutions and or the type of technical tools in support to the knowledge management initiatives. The application of these strategic technical tools can ensure better management of healthcare knowledge and (Limaye et al. 2015).

6. Top Management Reinforcement: the role of the top management in the healthcare organization is not addressed in this model. The commitment of the top management is key for enabling an effective knowledge management and required for proper knowledge dissemination within the organization (Irfan et al. 2014).

V THE PROPOSED HEALTHCARE KNOWLEDGE MANAGEMENT FRAMEWORK

The review of the previous studied models of knowledge management in healthcare organizations has resulted in the formation of six themes reflecting the gap analysis of these models. These themes reflected the shortcomings of each model and were

thoroughly explored and crosschecked with the elements consisting the three previous aforementioned models. The detected themes and gaps in these models has revealed sufficient information to form the proposed framework. The six themes forming the gap analysis has been utilized to express the constructs of the proposed model. The proposed Healthcare Knowledge Management Framework (hereinafter HKMF) aims to bridge the gaps indicated in the analysis of three previous models, the proposed framework is depicted in Figure 4.



Figure 4. The Proposed Healthcare Knowledge Management Framework (HKMF)

There are six interrelated elements for the proposed HKMF, these elements are acquiring of knowledge, people dealing with knowledge, knowledge-sharing culture, knowledge repository, ICT support and top management reinforcement. The proposed framework provides a holistic approach in dealing with knowledge management represented in the six interrelated elements. processes taking place when creating, storing, and sharing of knowledge within a selected healthcare organization These constructs and their respective roles are as follows:

1. **Acquiring of Knowledge:** this element will specify the entities involved in the knowledge acquisition in the healthcare organization. These entities could be personnel, department, training programs or factors affecting the knowledge acquisition in the healthcare organization. Furthermore, this element would have discussed the sources of knowledge and the learning facilities provided for the staff and which are essential for a successful knowledge management in healthcare organization (White, 2015).
2. **People Dealing with Knowledge:** focuses on the role of employee and their involvement in the entire knowledge management processes within the healthcare organization. this aspect is considered in the proposed framework for its immense value in the success of the knowledge management initiatives (Simon, 2016). This element will explain how the

employees are affecting the creation and transfer of knowledge, and how they are being affected by the learning and knowledge transfer within the healthcare organization.

3. **Knowledge-Sharing Culture:** the proposed framework will take into account the essential need for establishing and maintaining and organizational culture that encourages the sharing of knowledge. The setting of the knowledge-sharing culture is pivotal to the success of the knowledge management initiatives (Peralta and Saldanha, 2014). The formal and non-formal settings of knowledge-sharing activities will be considered in this element as well.

4. **Knowledge Repository:** this element of the proposed framework will clarify the processes followed when capturing and storing the organizational knowledge within the healthcare organization. Consequently, it will indicate the location and individuals dealing with the updating and maintaining of the knowledge repository within the healthcare organization. A well-defined knowledge repository will ensure better management of knowledge and will lead to a quality healthcare services (Ling et al. 2014).

5. **ICT Support:** this element refers to the strategic role of which ICT solutions can assume for better knowledge management in the healthcare organization. The advances in the technical tools and application will facilitate the creation, acquisition and sharing of knowledge. The proposed HKMF will include the implementation of of an ICT tool that is relevant to this ongoing research. This tool is known as KFTGA (Knowledge Flow Tracer and Growth analyzer) was developed by Syed Mustapha (2012) to capture the existing shared knowledge and to analyze the growth of that knowledge within the organization.

6. **Top Management Reinforcement:** this fundamental element indicates the importance of the top management's commitments for ensuring successful knowledge management initiatives. This element represented in a two-headed arrow across all other elements of the proposed framework in order to stress the necessity of top management's involvement in all other elements in HKMF. The support, encouragement and reinforcement of the top management are essential for smooth management of knowledge in the healthcare organizations (Kim, 2016). Additionally, top management's continuous overseeing of all process and elements in the proposed framework will ensure the flexible flow of knowledge among the communities of employees. Finally, the projected framework will have discussed the current state of knowledge domains and recommendations to improve them.

VI CONCLUSIONS AND FUTURE WORKS

This paper discussed the previous models of knowledge management in healthcare organizations as well as the creation, transfer and the use of medical knowledge by the medical and non-medical staff. Three models were reviewed and attention was paid to their components and the task of each component. Six common themes were synthesized from these models in order to understand the shortcomings of each model. These themes and their shortcoming were explained under a gap analysis for each of these models. The thorough study of these models will aid in realizing adequate methodology in approaching the problem of the knowledge management in healthcare organization. Additionally, understanding the weaknesses of these models will aid in developing the proposed framework while keeping in mind how to overcome them. The studied literature and previous models were lacking for an expansive and detailed focus on the role of top management in knowledge creation and sharing, thus it is worthwhile to exploit methods to overcome this gap. Additionally, the processes involved in the creation, transfer and application of knowledge within the healthcare organization might differ based on the job nature of each employee group (top management, physicians, medical assistants, clerks). Therefore, it would be valuable to investigate even further in these differences and what influence these differences when managing knowledge within a healthcare organization.

REFERENCES

- Abbate, T., Bassano, C., Coppola, A., Miranda, S. and Rarita, L. (2014). A Knowledge-based Decision Support System for the Service Quality Improvement in Organizations. In *7th International Workshop on Information Logistics and Knowledge Supply, ILOG*, 49-60.
- Ahlan, A. and Ahmad, B. (2015). An Overview of Patient Acceptance of Health Information Technology in Developing Countries: A Review and Conceptual Model. *International Journal of Information Systems and Project Management*, 3(1), 29-48.
- Alhalhouli, Z., Hassan, Z., and Der, C. (2014). Factors Affecting Knowledge Sharing Behavior among Stakeholders in Jordanian Hospitals Using Social Networks. *International Journal of Computer and Information Technology*, 3(5), 919-928.
- Araujo, C., Tavares, E., de Vargas, E. and Rocha, E. (2015). Developing Learning Capabilities Through a Quality Management Program. *The Service Industries Journal*, 35(9), 483-498.
- Badimo, K., and Buckley, S. (2014). Improving Knowledge Management Practices in the South African Healthcare System. *World Academy of Science, Engineering and Technology, International Journal of Social, Behavioral, Educational, Economic, Business and Industrial Engineering*, 8(11), 3445-3454.
- Baeshen, N. (2014). Knowledge Management Approaches for Business Intelligence in Healthcare. *Advances in Information Science and Applications*. vol.1, 275-278. ISBN: 978-1-61804-236-1.
- Bali, R., Baskaran, V., Arochena, H. and Naguib, R. (2009). Implementation of A Breast Cancer Screening Prediction Algorithm: A Knowledge Management Approach. *Biomedical Computing and Engineering Technologies (BIOCORE)*, Applied Research Group, Coventry University, p.23.
- Brooks, P., El-Gayar, O. and Sarnikar, S. (2015). A Framework for Developing a Domain Specific Business Intelligence Maturity Model: Application fo Healthcare. *International Journal of Information Management*, 35(3), 337-345.
- Buta, S. (2015). Human Capital Theory and Human Resource Management: Implications in Development of Knowledge Management Strategies. *Ecoforum Journal*, 4(1), 155-162.
- Cudney, E., Murray, S., Sprague, C., Byrd, L., Morris, F., Merwin, N. and Warner, D. (2015). Engaging Healthcare Users through Gamification in Knowledge Sharing of Continuous Improvement in Healthcare', *Procedia Manufacturing*, vol. 3, 3416-3423.
- Gattnar, E., Schneider, J., Stroetmann, B. and Ekinci, O. (2015). Knowledge Management and Collaboration Analysis of the Siemens Healthcare Consulting Group. *Journal of Recent Advances in Telecommunications, Informatics and Educational Technologies*, 22-26, ISBN: 978-1-61804-262-0.
- Irfan, S., Kee, D., Qureshi, R. and Hussain, R. (2014). Identification of Critical Success Factors of TQM Implementation in Health Care Sector of Pakistan Using Pareto Analysis Approach. *Science international*, 26(5), 2603-2616.
- Kahle-Piasecki, L. and Doles, S. (2015). A Comparison of Mentoring in Higher Education and Fortune 1000 Companies: Practices to Apply in a Global Context. *Journal of Higher Education Theory and Practice*, 15(5), p.74.
- Khammarnia, M., Shahsavani, F., Shahrakipour, M. and Barfar, E. (2014). Relationship Between Knowledge Management and Quality of Working Life in Nursing Staff of Zahedan Teaching Hospitals', *Health Scope Education*, 15(19), 8-6.
- Kim, R. (2016). The US Hospital Management from a Strategic Management Viewpoint. *Hospital Medical Management*. 1(2), 1-7.
- Knauth, D. and Meinerz, N. (2015). Reflections on Sharing Data from Healthcare Anthropological Studies. *Ciencia and Saude Coletiva*, 20(9), 2659-2666.
- Lau, F. (2004). Toward A Conceptual Knowledge Management Framework in Health. *Perspectives in Health Information Management/AHIMA*, American Health Information Management Association.
- Limaye, R., Deka, S., Ahmed, N., and Mwaikambo, L. (2015). Designing eLearning Courses to Meet the Digital Literacy Needs of Healthcare Workers in Lower- and Middle-Income Countries: Experiences from the Knowledge for Health Project. *Knowledge Management and E-Learning: An International Journal (KM&EL)*, 7(4), 601-615.
- Ling, Z., Tran, Q., Fan, J., Koh, G. C., Nguyen, T., Tan and Zhang, M. (2014). Gemini: An Integrative Healthcare Analytics System. *Proceedings of the VLDB Endowment*, 7(13), 1766-1771.
- Matshwane, O. (2015). Knowledge Management in the IT Outsourcing Service Industry of South Africa: a Case of Western Cape and Gauteng Provinces, thesis, Cape Peninsula University of Technology, Retrieved from, http://digitalknowledge.cput.ac.za/jspuibitstream11189/3181/1/205106757_Matshwane_OL_Mtech_IT_Fid_2015.pdf
- Olkiewicz, M. (2015). Knowledge Management as a Determinant of Innovation in Enterprises. *Proceedings of The 9th International Management Conference "Management and Innovation For Competitive Advantage", November 5th-6th, 2015, Bucharest, Romania*. 399-409.
- Peralta, C. and Saldanha, M. (2014). Knowledge-Centered Culture and Knowledge Sharing: The Moderator Role of Trust Propensity. *Journal of Knowledge Management*, 18(3), 538-550.
- Platis, C., Reklitis, P. and Zimeras, S. (2015). Relation between Job Satisfaction and Job Performance in Healthcare Services. *Procedia-Social and Behavioral Sciences*, 1(175), 480-487.
- Ramli, R., and Ali, N. (2015). Teleconsultation: An Insight from the Knowledge Management Perspectives. *The International Journal of Business and Management*, 3(8), 86.
- Rashid, A. and Ahmad, Z. (2016). Assessing Impacts of Organizational Factors on Knowledge Sharing Behavior in Iraqi Textile Industry. *International Review of Management and Business Research*, 5(1), 24-35.

- Ratnapalan, S., & Uleryk, E. (2014). Organizational Learning in Health Care Organizations. *Systems*, 2(1), 24-33.
- Rexhepi, H. (2015). Improving Healthcare Information Systems - A Key to Evidence-based Medicine, thesis, University of Skövde, Sweden, ISBN 978-91-981474-7-6.
- Safwan, E., Meredith, R. and Burstein, F. (2016). Business Intelligence (BI) System Evolution: A Case in A Healthcare Institution. *Journal of Decision Systems*, 25(S1), 463-475.
- Simon, L. (2016). *The Relationship between Knowledge Management Tools and Interprofessional Healthcare Team Decision Making*. Walden University, Minnesota, USA.
- Stary, C. (2016). Open Organizational Learning: Stakeholder Knowledge for Process Development. *Knowledge Management & E-Learning: An International Journal (KM&EL)*, 8(1), 86-108.
- Syed Mustapha (2012). KFTGA: A Tool For Tracing Knowledge Flow and Knowledge Growth in Knowledge Sharing Environment. *Journal of Information Knowledge Systems Management*, 11(3), 205-224.
- Tahamtan, I. and Sedghi, S. (2014). Perceived Benefits and Barriers of Handheld Computers in Clinical Practice. *Health Scope*, 3(4),1-4.
- Tabrizi, N., and Morgan, S. (2014). Models for Describing Knowledge Sharing Practices in the Healthcare Industry: Example of Experience Knowledge Sharing. *International Journal of Management and Applied Research*, 1(2), 48-67
- White, G., and Cicmil, S. (2016). Knowledge Acquisition Through Process Mapping: Factors Affecting The Performance Of Work-Based Activity. *International Journal of Productivity and Performance Management*, 65(3), 302-323.
- Wickramasinghe, N. (2010). Healthcare Knowledge Management: Incorporating the Tools Technologies Strategies and Process of KM to Effect Superior Healthcare Delivery. In *Perspectives of Knowledge Management in Urban Health*,21-38, Springer New York.

Fuzzy Distance-based Undersampling Technique for Imbalanced Flood Data

Ku Ruhana Ku Mahamud, Maisarah Zorkeflee, and Aniza Mohamed Din

Universiti Utara Malaysia, Malaysia, {ruhana; maizsarah; anizamd}@uum.edu.my

ABSTRACT

Performances of classifiers are affected by imbalanced data because instances in the minority class are often ignored. Imbalanced data often occur in many application domains including flood. If flood cases are misclassified, the impact of flood is higher than the misclassification of non-flood cases. Numerous resampling techniques such as undersampling and oversampling have been used to overcome the problem of misclassification of imbalanced data. However, the undersampling and oversampling techniques suffer from elimination of relevant data and overfitting, which may lead to poor classification results. This paper proposes a Fuzzy Distance-based Undersampling (FDUS) technique to increase classification accuracy. Entropy estimation is used to generate fuzzy thresholds which are used to categorise the instances in majority and minority classes into membership functions. The performance of FDUS was compared with three techniques based on F-measure and G-mean, experimented on flood data. From the results, FDUS achieved better F-measure and G-mean compared to the other techniques which showed that the FDUS was able to reduce the elimination of relevant data.

Keywords: imbalanced flood data, resampling technique, fuzzy distance-based undersampling, fuzzy logic.

I INTRODUCTION

Minority and majority data classes that exist in any imbalanced data sets can be found in many cases including flood prediction. For binary classification, data set is defined as imbalanced if the ratio of two classes is not less than 19:1 (Ding, 2011). The problem that is related to imbalanced data is poor classification performance. Since the size of minority class is lesser than majority class, classifiers will only classify the majority class which leads to poor accuracy because classifiers assume that the distribution of data in both classes is equal (Li, Zou, Wang & Xia, 2013). Hence, to overcome this problem, undersampling and oversampling techniques have been developed.

Random undersampling (RUS) technique is one of the undersampling techniques. RUS removes the instances in majority class randomly until the desired ratio of balanced set is achieved. RUS is easy to be used; however, the random data removal may lead to the loss of useful data (Chairi, Alaoui & Lyhyaoui, 2012). Distance-based Undersampling (DUS) is a technique that discards instances by averaging the distance between instances in minority and majority classes (Li et al., 2013).

In order to estimate class distribution between samples in majority and minority classes, fuzzy logic has been introduced in undersampling technique (Li, Liu & Hu, 2010). The membership function for majority class is based on Gaussian function and α -cut to remove the instances. To deal with large data sets, fuzzy logic is applied to cluster the samples in the majority class to make a selection of which instances are important (Wong, Leung & Ling, 2014). However, the setting of the membership function depends on the calculation of mean value which is sensitive to skewed data sets.

Random oversampling (ROS) randomly duplicates the samples in the minority class. The drawback of ROS is it creates overfitting (Chairi et al., 2012). Synthetic Minority Oversampling Technique (SMOTE) is the commonly used oversampling technique that creates new synthetic samples to the majority class by finding k-nearest neighbour along the minority class (Chawla, Bowyer & Hall, 2002). Results from several experiments conducted showed that undersampling technique produced better classification accuracy than oversampling technique (Bekkar & Alitouche, 2013).

For evaluation purpose, accuracy is not suitable to be used for imbalanced data sets because the minority class has a small impact to the classifier. Instead, Geometric mean (G-mean) and F-measure are used to evaluate the classification performance for imbalanced data sets (He & Garcia, 2009). G-mean is suitable because it is independent towards imbalanced distribution, while F-measure is a combination of precision and recall that shows the effectiveness of a classifier.

In Section 2, an explanation on the proposed undersampling technique is presented. Section 3 describes the performance evaluation and the conclusion is provided in Section 4.

II THE PROPOSED FUZZY DISTANCE-BASED UNDERSAMPLING TECHNIQUE

Fuzzy Distance-based Undersampling (FDUS) technique is an enhancement of Distance-based Undersampling (DUS) by implementing fuzzy logic to the algorithm. Figure 1 shows the algorithm of the proposed FDUS technique to remove instances from majority class.

- i. Divide data into majority and minority group
- ii. For all data, calculate distance between majority and minority data
- iii. Categorize the calculated distance based on fuzzy threshold
- iv. Compute fuzzy logic threshold using entropy estimation
- v. Remove instances based on trapezoidal and triangular membership functions

Figure 1. Fuzzy Distance-based Undersampling algorithm

Figure 2 illustrates the membership function of the instances. The trapezoidal and triangular membership functions in the figure represent three sets of instances to show the instances that needed to be kept, removed temporarily or removed permanently. Fuzzy logic thresholds are represented as a , b and c .

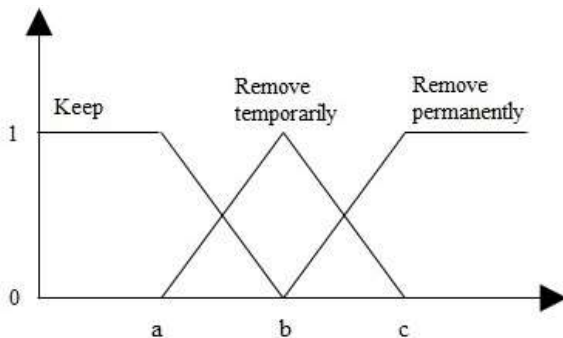

Figure 2. Membership Function of Instances

For instances that belong to the 'keep' set, the instances will remain in the majority class. The 'remove permanently' set represents the instances that will be removed immediately. At this stage, a new majority class is created. For instances that is categorised in 'remove temporarily', the decision of removing the instances will be based on two conditions. These conditions are applicable after considering the size of the new majority class. The first condition is when the number of instances in the new majority class is more than the instances in the minority class. In this case, the instances in the 'remove temporarily' set will be removed immediately. For the second condition, if the number of instances in the new majority class is

lesser than the minority class, then the instances will be kept. Finally, new data set with minimal loss of potential data is generated. A balanced data set is produced based on fuzzy thresholds.

III PERFORMANCE EVALUATION

The experiments conducted are designed to minimise the removal of potential data from the majority class. In this paper, data sets from Kaki Bukit, Lubok Sireh, Wang Kelian, Ladang Perlis Selatan and Ulu Pauh from year 2005 until 2013 are used. The pre-processed imbalanced flood data are divided into majority and minority classes. Then, 5-fold cross validation is used to partition the data sets into 4:1 train to test ratio. The proposed FDUS is applied on the training and testing sets and SVM is used for classification. The classification is evaluated by accuracy, F-measure and G-mean. The results from five experiments for each data set are averaged. For comparison purposes, the whole process is repeated using different techniques, which are DUS and SMOTE. Testing is also made on the data sets without applying any undersampling or oversampling technique to analyse whether the use of those techniques are beneficial.

Table 1 is a sample of rainfall and water level data. Rainfall is measured in millimeter (mm), while water level is measured in meter (m) unit. Both rainfall and water level are presented in hourly forms.

Table 1. Sample of Rainfall and Water Level Data

Rainfall Data (mm) for Sungai Pelarit					
	0100	0200	0300	...	2400
1/12/13	0	0	0		0
Water Level Data (m) for Wang Kelian					
	0100	0200	0300	...	2400
1/12/13	10.21	10.24	10.24	...	10.27

Collected rainfall and water level data are cleaned up from any outliers. For this case, any point that is separated far from other points is considered as outliers. To deal with outliers, the points are corrected by replacing a close approximation point of the remaining values. In order to fill the missing value, interpolation technique is used as described in Equation 1.

$$f(x) = f(x_0) + (x - x_0) \frac{f(b) - f(a)}{b - a} \quad (1)$$

where $f(x)$ = estimation value, $f(x_0)$ = value before missing value, x = point of missing value, x_0 =

point of value before missing value, $f(a) = \text{constant}$ value before missing value, $f(b) = \text{constant}$ value after missing value, $a = \text{constant}$ point before missing value and $b = \text{constant}$ point after missing value.

After data cleaning, rainfall and water level data sets are combined. These two attributes will determine the flood occurrence for each catchment area. Table 2 shows the relations of rainfall and water level stage that cause floods (Bedient, Huber & Vieux, 2008). Table 3 presents a sample of flood data set after the rainfall and water level data are combined. The division of no flood and flood classes are done based on Table 2.

Table 2. Causes of Flood (Bedient, Huber & Vieux, 2008)

	Rainfall	Water level stage	Class
Stage	Heavy or very heavy	Warning or danger	Flood
	Heavy or very heavy	Alert	Flood
	Light or moderate	Warning or danger	Flood
	Light or moderate	Alert	No flood

Table 3. Sample of Ulu Pauh Data Set

Date	Time	Rainfall (mm)	Water level (m)	Class
29/3/2009	2.00pm	0	25.67	No flood
29/3/2009	4.00pm	67.30	25.72	Flood
29/3/2009	6.00pm	0.10	28.12	No flood

Table 4 provides details of the flood data sets that include size of the data sets, number of instances in flood class (#Flood), number of instances in no flood class (#No flood), and ratio of majority class to minority class. The imbalanced ratio is defined as the ratio of number of instances in majority class to the number of instances in minority class. Minority and majority classes represent flood and no flood occurrence, respectively.

The results of classification accuracy for no resampling technique, FDUS, DUS and SMOTE are presented in Table 5. FDUS produced the best mean classification accuracy on Kaki Bukit and Ulu Pauh

and produced the second best mean classification accuracy on Ladang Perlis. The average of mean classification accuracy and the standard deviation for FDUS are the highest compared to no resampling, DUS and SMOTE. However, even though the standard deviation is ranked as the highest, the value is considered low as stated in Orriols-Puig and Bernado-Mansilla (2009).

Table 6 shows the F-measure for the proposed FDUS and other resampling techniques. FDUS performed the best when it is applied on Wang Kelian and Ulu Pauh data sets compared to the other techniques. For the rest of the data sets, FDUS performed as the second best technique. On average, FDUS gave the best F-measure.

The results of G-mean for flood data sets are summarised in Table 7. The results show that FDUS worked better than DUS and SMOTE for Kaki Bukit, Lubok Sireh, Wang Kelian and Ulu Pauh. On average, FDUS performed as the second best technique after no resampling.

The results of classification accuracy indicated that FDUS allows SVM to classify the data sets correctly specifically on the Kaki Bukit and Ulu Pauh data sets. The classification accuracy is higher on Kaki Bukit and Ulu Pauh data sets because the ratio between majority and minority classes has become smaller when FDUS is applied on the data sets. However, for the other flood data sets, FDUS has lower classification accuracy than no resampling, DUS and SMOTE. This might happen due to other factors such as size, complexity, overlap and small disjuncts (Barua, Islam, Yao, & Murase, 2014).

F-measure determines the exactness of the correctly labelled minority class. Based on Table 6, FDUS appeared as the best technique for two times and second best technique for three times. FDUS is able to adjust the ratio between instances in minority class to instances in majority class to maximize the value of F-measure. High G-mean signifies the accuracy of majority and minority classes is high and the gap between both classes is small. FDUS performed better than DUS and SMOTE. However, FDUS is outperformed by no resampling because the sensitivity and specificity are high. FDUS uses the advantage of fuzzy logic to avoid biasness in choosing the instances that need to be removed from the majority class. Overall, it is apparent that FDUS achieved higher classification accuracy and F-measure and has the highest G-mean.

Table 4. Characteristics of Flood Data Sets

Data sets	Record size	#Flood	#No flood	Ratio (maj:min)
Kaki Bukit	157,775	75	157,700	2102:1
Lubok Sireh	157,775	75	157,700	2102:1
Wang Kelian	157,775	76	157,699	2074:1
Ladang Perlis Selatan	157,775	163	157,612	966:1
Ulu Pauh	157,775	128	157,617	1231:1

Table 5. Classification Accuracy (%) of Standalone Techniques for Flood Data Sets

Resampling technique	No resampling		FDUS		DUS		SMOTE	
	Mean	Standard deviation	Mean	Standard deviation	Mean	Standard deviation	Mean	Standard deviation
Kaki Bukit	99.90	1.87	99.94	0.61	99.67	0.06	99.88	0.19
Lubok Sireh	99.89	0.22	99.80	1.96	99.94	0.56	99.97	0.19
Wang Kelian	99.70	0.34	99.82	1.98	99.96	0.49	99.84	0.20
Ladang Perlis	99.89	0.22	99.94	0.61	99.95	0.63	99.89	0.39
Ulu Pauh	99.60	0.23	99.99	1.22	99.95	0.64	99.89	0.22
Average	99.80	0.58	99.90	1.28	99.89	0.48	99.89	0.24

Table 6. F-measure of Standalone Techniques for Flood Data Sets

Resampling technique	No resampling	FDUS	DUS	SMOTE
Data set				
Kaki Bukit	0.49	0.81	0.85	0.81
Lubok Sireh	0.48	0.84	0.74	0.87
Wang Kelian	0.49	0.85	0.84	0.53
Ladang Perlis	0.65	0.81	0.92	0.79
Ulu Pauh	0.65	0.99	0.87	0.75
Average	0.55	0.86	0.84	0.75

Table 7. G-mean of Standalone Techniques for Flood Data Sets

Resampling technique	No resampling	FDUS	DUS	SMOTE
Data set				
Kaki Bukit	0.99	0.93	0.87	0.90
Lubok Sireh	1.00	0.97	0.82	0.96
Wang Kelian	0.99	0.99	0.96	0.90
Ladang Perlis	1.00	0.93	0.98	0.90
Ulu Pauh	0.99	0.99	0.88	0.90
Average	0.99	0.96	0.90	0.91

IV CONCLUSION

Undersampling technique is chosen to solve the problem of imbalanced data sets, because based on previous research works, the technique performed better than oversampling technique. In this paper, Fuzzy Distance-based Undersampling (FDUS) technique is proposed. FDUS used the advantage of fuzzy logic which is to avoid bias in removing instances in the majority class, and hence minimise the loss of useful data. Based on the experimental results, FDUS produced the best classification accuracy and F-measure on the flood data sets. Based on G-mean value, FDUS is better than DUS and SMOTE but performed lesser than no resampling.

ACKNOWLEDGMENT

The authors wish to thank the Ministry of Education, Malaysia for funding this study under the Long Term Research Grant Scheme (LRGS/b-u/2012/UUM/Teknologi Komunikasi dan Infomasi).

REFERENCES

- Barua, S., Islam, M., Yao, X., & Murase, K. (2014). MWMOTE--majority weighted minority oversampling technique for imbalanced data set learning., *IEEE Transactions on Knowledge and Data Engineering*, 26(2), 405-425.
- Bekkar, M., & Alitouche, T. A. (2013). Imbalanced data learning approaches. *International Journal of Data Mining & Knowledge Management Process (IJDMP)*, 3(4), 15-33.
- Chairi, I., Alaoui, S., & Lyhyaoui, A. (2012). Learning from imbalanced data using methods of sample selection. In *2012 International Conference on Multimedia Computing and Systems (ICMCS)*, 254-257.
- Chawla, N. V., Bowyer, K. W., & Hall, L. O. (2002) SMOTE : Synthetic Minority Over-sampling Technique, *Journal of Artificial Intelligence Research*, 16, 321-357.
- Ding, Z. (2011). Diversified ensemble classifiers for highly imbalanced data learning and their application in bioinformatics, in *Computer Science Dissertations*, Department of Computer Science, Georgia State University.
- He, H., & Garcia, E. A. (2009). Learning from imbalanced data. *IEEE Transactions on Knowledge and Data Engineering*, 21(9), 1263-1284.
- Li, D.-C., Liu, C.-W., & Hu, S. C. (2010). A learning method for the class imbalance problem with medical data sets. *Computers in Biology and Medicine*, 40(5), 509-518.
- Li, H., Zou, P., Wang, X., & Xia, R. (2013). A new combination sampling method for imbalanced data. *Proceedings of 2013 Chinese Intelligent Automation Conference*, 547-554.
- Orriols-Puig & Bernado-Mansilla (2009). Evolutionary rule-based systems for imbalanced data sets. *Soft Computing*, 13(3), 213-225.
- Wong, G. Y., Leung, F. H., & Ling, S. H. (2014). An under-sampling method based on fuzzy logic for large imbalanced data set. In *2014 IEEE International Conference on Fuzzy Systems (FUZZ-IEEE)*, 1248-1252.

eBusiness Adoption Studies in Thailand

Suttisak Jantavongso, Chuleekorn Nuansomsri, Sumana Kasemsawasdi, Somboon Anekritmongkol, and Saritkan Sitthikraiwong

Rangsit University, Thailand, { suttisak.j; chuleekorn.n; sumana.k; somboon.a; saritkan.s}@rsu.ac.th

ABSTRACT

Electronic Business or eBusiness over the Internet enables businesses (whether large or small) to do more than buying or selling their products and services. eBusiness is now including all network based transactions, collaborations, and interactions with customers, suppliers, and business partners. Given the economic dominance of Western economies in fields such as eBusiness, a number of questions arise associated with the suitability of lessons learned in the West to eBusiness developments in Thailand. In particular, the authors have noted that most existing eBusiness adoptions are designed to cater for businesses in Western countries; and this raises the question of whether these adoptions are suited to businesses in Thailand. In this regard, the authors are of the opinion that a study explicitly on eBusiness is required to assist businesses in Thailand to adopt and engage in eBusiness successfully. The research findings provide the foundation for future research aimed at developing a framework to guide businesses in Thailand, to successfully implement the new generation of eBusiness activities, which include sCommerce (Social Commerce) and sBusiness (Social Business).

Keywords: eBusiness, eCommerce, sCommerce, sBusiness, Critical success factor (CSF)

I INTRODUCTION

Electronic Business (eBusiness) is an evolution of traditional business practices. It is designed to take advantages of the new technologies of the Internet age. eBusiness did not suddenly appear. Rather, the first electronic stores (eStores) appeared since 1993 (Philipson, 2002). An early example of such eStores was the “PizzaNet” Homepage in 1994 (Mitchell, 1995).

By 2018, according to eMarketer (2014), the worldwide eBusiness market will be worth \$2.5 trillion compared with \$40 billion in 1999 (Philipson, 2002). Moreover, the world has become a global village in reality (Singh & Waddell, 2004). It will be difficult for businesses to survive without engaged the management and technology complexities in eBusiness to sustain the innovations. In addition, Thailand in 2015 was ranked 5th in terms of time spent on Social Media each day. Thailand is

also ranked 2nd place in the world with most LINE application users after Japan. 50 percent of Thais have an active Social Media account and are actively

on mobile devices. Facebook is the top active social platform for Thais. Social Media in Thailand was dated back to 1995 when the Internet became commercialized. “Talk on Unix”, “Pirch”, “ICQ”, “QQ”, and “MSN Messenger” were once, five of the most popular Social Media applications in Thailand (Jantavongso, 2015).

Notwithstanding, eBusiness can provide businesses with a gateway to participating and contributing to global business. Most significantly from a developing country’s point of view, such as that of Thailand, ‘*the adoption of eBusiness offers the potential of advancing directly to being world competitive without the necessity to follow the traditional Western development path involving considerable time and expense*’ (Jantavongso, 2007). Given the economic dominance of well-developed Western economies in fields such as eBusiness; ‘*the question of whether Thailand can bridge the gap to become an advanced country doing global business*’, is a question of great interest.

While there are a number of studies have been conducted on eCommerce, limited research have been conducted on eBusiness in Thailand (Intrapairot & Srivihok, 2003; Kini & Thanarithiporn, 2004; Laosethakul & Boulton, 2007; Lertwongsatien & Wongpinunwatana, 2003; Limthongchai & Speece, 2003; Pimsawadi & Digman, 2012; Sebor, Lee, & Sukasame, 2009; Suanpang, 2014; Sutanonpaiboon & Pearson, 2006). In this regard, the authors are of the opinion that a study explicitly on eBusiness is required to assist businesses in Thailand to adopt and engage in eBusiness. As such, the authors have been engaged in the study of eBusiness in Thailand since 2003 (Blashki & Jantavongso, 2006; Jantavongso, 2007; Jantavongso, Li, & Tootell, 2003; Jantavongso, Sugianto, & Syau, 2007; Sugianto & Jantavongso, 2006)

For this reason, this paper describes a number of the Critical Success Factors (CSF) for eBusiness from a Thai perspective in the current environment. The paper is an introductory article for those who are interested, but not familiar with the roles of eBusiness in Thailand.

II RESEARCH APPROACH

The research method adopted in this study is based on the information systems research approach proposed by Shanks et al (1993), which employs a

positivist research framework. The research framework proposes a research cycle consisting of three stages, theory building, theory testing, and theory refinement.

This paper reports the results from the first stage of theory building and in this study involved a review of the literature on relevant research domains. A literature survey was conducted first, which focused on the domain of eBusiness and Thailand.

III EBUSINESS

The term 'eBusiness' was first appeared in 1997 by IBM (Jantavongso, 2007). Prior to this era, the term 'eCommerce' was more often used. Recently, Social Commerce (sCommerce) is becoming a common term involving an online business. sCommerce is not a new term. Yahoo! coined the term sCommerce in 2005 (Marsden, 2010). The terms eBusiness and eCommerce can often be used interchangeably. However, they have different meanings. While eCommerce refers to aspects of doing online businesses involving exchanges among customers, business partners and suppliers; eBusiness encompasses these elements as well as activities that are handled within the business itself (Deitel, Deitel, & Nieto, 2003).

eBusiness is more than simply having a website for a business. As such, eBusiness not only encompasses tools such as technology, mobile devices, and the Internet; but eBusiness also covers the application of Social Media to improve the business processes. One of the most widely recognized examples of an eBusiness is Amazon.com. Established in 1994, Amazon.com has now become one of the largest eBusinesses (Deitel et al., 2003).

The last few years have been observed a rapidly growth in a number of Social Media users and an advancement in Social Media technology. Social Media have evolved as a result of Web 2.0 concepts (coined in 1999) and new media technologies (Croteau & Hoynes, 2014). People around the world are at this time interacting with each other through Social Media networking to communicate their shared interests, activities and disseminate information. Moreover, Social Media such as Facebook and Twitter alone have become enormously popular across demographics of race, age and gender and have billions of users (Utz & Muscanell, 2015). According to Patterson (2011), Social Media is underpinned by the ideological and technological of Web 2.0. Web 2.0 is a collection of interactive capacities, suggested a technological change from Web 1.0 (the Internet origin). Web 2.0 enabled the rise of blogs, Social Media networking sites, content platforms, collaborative wikis, virtual game worlds, social bookmarking, and virtual worlds (Croteau,

Hoynes, & Milan, 2012).

This implies that Social Media has now become a significant part of the ways people communicate, and share a wide variety of information. For this reason, it is not unexpected that Social Media truly has provided new methods of conducting business activities and reaching customers for businesses. Applications such as Facebook, Twitter, LINE, LinkedIn, Google Plus, Blogs, WhatsApp, Tango, WeChat, Instagram, YouTube, and Skype provide businesses with significant business building communities based on interests and relationships.

Advancements of Social Media have extended the inclusion of eBusiness to Social Business (sBusiness) and Social Commerce (sCommerce). sCommerce is made possible by Social Media. sCommerce has provided businesses with extra tools of approaching, acquiring, and retaining customers with the use of Social Media technologies (Lee, 2013). sCommerce empowers customers to a better and informed decision by allowing customers to search for other customers' reviews and comments prior purchasing a product or service.

Put simply, sCommerce is conducting business in a collaborative and participative method, by applying Social Media, through a business interactive interface that enables social interactions (Baghdadi, 2013). It is the use of Social Media technology and networks to produce businesses.

On the other hand, sBusiness is more emphasized on business operations and generate value. Social Media are tasks that apply Social Media, applications, networks to allow more efficient, effective and useful connection between people, information, and assets. These connections drive business decisions, actions, and results across the business (Kiron, Palmer, Phillips, & Kruschwitz, 2012).

IV CRITICAL SUCCESS FACTORS

The Critical Success Factor (CSF) is a term for an element that is required for a business to meet its goal. It is a critical factor that must be done exceedingly well for a business to be successful (Gates, 2010). The next section continues the work from the previous studies by the authors (Blashki & Jantavongso, 2006; Jantavongso, 2007, 2013b; Jantavongso & Li, 2003; Jantavongso et al., 2003; Jantavongso et al., 2007; Oh, Jantavongso, & Li, 2004; Sugianto & Jantavongso, 2006).

A. eBusiness Readiness

Countries such as the United States, Australia, England, other European countries, and Singapore have a high level of 'eBusiness Readiness' (Jantavongso, 2013b). In this study, eBusiness Readiness measures the capability of business

environment to seize Internet-based commercial opportunities. Meanwhile, eBusiness may aid businesses in gaining competitive advantages over their rivals, as well as improving the ways in which businesses perform their processes. Unfortunately, it incurs a high level of implementation risk. Businesses need to be able to assess their business whether they are really ready for implementing eBusiness.

B. eBusiness Infrastructure

eBusiness infrastructure covers Internet connectivity, the telecommunications structure, the logistics structure and the web strategies required to support eBusiness activities. Internet connectivity refers to the availability of high speed communications links that enable the transmission of data and information between people. Communication links include fiber optic cables, wireless communication networks and telephone lines which are supported by the telecommunications structure.

The logistics system includes processes necessary to transfer the physical goods to the customers after they have been sold over the Internet. The logistics system for this is no different from the logistics system of traditional businesses and eBusiness requires the logistics infrastructure for material deliveries and transportation, and, material flow control. As such, the logistics system comprises the transportation infrastructure, the postal infrastructure and public infrastructure such as electricity, airports, seaports, railways and highways.

According to the Board of Investment of Thailand: BOI (2015), Thailand has the necessary infrastructure to support eBusiness activities. These infrastructure includes modernized transportation facilities, as well as upgraded communications and IT networks.

Thailand's telecommunications services are at an international standard, particularly in city areas such as Bangkok. There is an abundance of fixed lines for businesses and residences. Local telephone calls are not timed and carry a fixed charge of THB 3 (\$0.10) per call. The fixed telephone line network has a total capacity of over 8 million lines, of which about 7 million are in use. 94 million are mobile phone subscribers (Board of Investment of Thailand, 2015). Of these, 1.8 million are 4G LTE mobile subscribers.

Mobile broadband connectivity is another important enabler for the digital economy and for eBusiness inclusion in Thailand. These trends are expected to continue over the next few years, as operators continue to enhance both 3G and 4G networks after the completion of the first Thailand's 4G spectrum auction in November 2015. The introduction of 4G services will minimize the barrier between the online and offline world. Users will benefit from faster and more reliable mobile data services, as well as

improved efficiency and productivity. 4G deployment would help transform Thailand into a true digital economy, driving the adoption and growth of new and innovative services such as online businesses (Pornwasin, 2015b).

In relation to the Internet connectivity infrastructure, according to National Electronics and Computer Technology Center (NECTEC) (National Electronics and Computer Technology Center, 2015), there were 39 commercial Internet Service Providers (ISPs) operating in Thailand. Moreover, as noted by the Board of Investment of Thailand (Board of Investment of Thailand, 2015), the Thai government committed itself to making broadband Internet available and affordable to the general public. Internet international bandwidth is at 1,340 Gbps. The total domestic bandwidth is at 2,169 Gbps. Accordingly, eCommerce usage is at 67 percent. In 2015, 28 million are Internet users compared with only 30 users in 1991 (Charmonman, 2007). Of these numbers the broadband Internet users is at 6 million. eCommerce market by the end of 2016 is expected to reach THB 1 trillion (Board of Investment of Thailand, 2015) compared with THB 400,000 in 2006 (Charmonman, 2007). The Thai government committed \$2.6 billion in 2012 to extend the national fiber optic broadband network. The goal is to make high speed Internet available to 95 percent of the population by 2020 (Singapore Post Limited, 2015).

Thailand has a good transportation infrastructure when compared to other ASEAN countries (Sullivan, 2015). Thailand's logistics cost is on a declining trend. Logistics cost per Gross Domestic Product (GDP) from a range of 16 to 18 percent during 2001 to 2008 to a range of 14 to 15 percent during 2009 to 2012 (Board of Investment of Thailand, 2014). While there are a number of logistics service providers to facilitate eBusinesses in Thailand, one is of noted as follows.

Thailand Post is providing integrated logistics services such as pick-and-pack services to warehouse management, distribution and transport management, and money collection. Thailand Post has countrywide logistics facilities can assist businesses to reduce the logistics costs. It is able to provide efficient transport and logistics structures due to 5,000 post offices and major distribution centers in regional provinces across Thailand. According to Leesa-nguansuk (2015), it offers 10 to 20 percent lower costs than other private logistics service providers

C. Thai Business Culture

Thailand has a strong business environment with a good mix of foreign and local investors. It has a high demand for imports as well as being strong in exports. Thailand has its own social and business culture, and

is a unique society. A business culture is one of the factors that influence the successful implementation of eBusiness.

Chongruksut (2002) examines Thai business culture from an internal prospective defining Thai business culture as a system of patronage. The patronage system is a significant characteristic of Thai business culture and involves adherence to personal relationships rather than to regulation of an institution. The relationships are based on cultural values and a set of norms, for example, that the younger must respect the older. This norm permeates most Thai businesses.

The U.S. Department of Commerce (2009) advises that the business relationships in Thailand are not as formal as those found in China, Japan, Korea, or the Middle East, but neither are they as relaxed and impersonal as is commonly found in the West. Many business relationships have their foundations in personal ties developed within the social circles of family, friends, classmates, and office colleagues. Although Thailand is a relatively open and friendly society, it is not advisable to approach potential business contacts without a prior introduction or personal reference. In general, Thai people will be more receptive if an introduction or letter from a known government official or mutual business associate is presented.

D. Law Related to eBusiness

The legal and regulatory environments required to support growth in the digital economy are significantly different from those needed to support traditional businesses. This presents challenges to the government as a new, or extended, legal framework is now required to support and regulate the unique aspects of eBusiness (Jantavongso, 2007).

In particular, the legal framework should include support for the use of digital signatures, digital certificates in virtual transactions and the regulations governing online transactions. The government must provide transparent, market-favorable regulation and legislation at both national and international levels to address the issues brought by the new digital economy. Suitable environments must be set in place to support security, secrecy and non-repudiation of digital transactions. Furthermore, the government needs to ensure that existing regulations do not hinder the growth of new or existing markets over the Internet. At the same time, the new regulations should be flexible enough to cater for global policy shifts and further changes in technology (Jantavongso, 2007).

While there is no specific laws relating to eBusiness in Thailand, there are Acts which relate to eCommerce as follows. According to Panusapthna (2013), Thailand has adequate legal provisions to

support electronic transactions. Panusapthna (2013) also believed that Thailand are suitable to support the rapid growth and development of eCommerce. The details of these laws are as follows.

The Electronic Transactions Act of B.E.2544 (2001) is to provide legal recognition of electronic transactions by enabling them to have the same legal effect as that given to transactions made by traditional paper means. The Act ensures a regulatory environment in order to promote the reliability of eCommerce (Panusapthna, 2013).

The Computer Crime Act of B.E.2550 (2007) or CCA supports the ICT infrastructure by ensuring the security and building confidence of interested parties in performing electronic transactions. The CCA aimed at preventing and suppressing the commission of a computer related offences. The CCA stipulates offences related to: (i) computer system, (ii) computer data, and (iii) providing of tools used in committing a computer crime (Panusapthna, 2013).

Consumer Protection Act of B.E.2522 (1979) provides consumers a protection against false, misleading and unfair advertising of goods and services. Consumer Protection Act ensures that consumers shall have the same rights irrespective of whether the transaction is carried out electronically or by traditional means (Panusapthna, 2013).

Direct Selling and Direct Marketing Act of B.E.2545 (2002) refers to electronic transaction. This is because of electronic transaction is under the term “direct marketing” of the Act. Sellers who provide their goods or services to customers through electronic means must be comply with the provisions of the Act (Panusapthna, 2013).

Credit Information Business Act B.E.2545 (2002) is associated with measurements to protect credit information.

Offence Relating to the Electronic Card Section 269/1-269/7 of the Criminal Code B.E.2499 (1956) Amended B.E.2547 (A.D.2004) deal with the offenses relating to fraud credit card making, unauthorized use of another person’s electronic card (Singsangob, 2005).

Personal Data Protection Bill is under drafting process. It covers legal protection of personal data on both consumer and business information. With valuable data is now easily transferable, the Thai government has been obliged to move to protect individuals from the misuse or abuse of their personal information, especially from commercial exploitation (ZICOLaw, 2015).

Finally, *Copyright Act (No. 2) B.E.2558 (2015)* includes responsibility of intermediaries, or Internet Service Providers (ISPs), for infringement of

copyright work on the Internet. Copyright Act will provide stronger protection to owners of intellectual property rights, especially movies and other digital content. This Act will promote the growth of original-content creators to support online businesses (Pornwasin, 2015a; Tunsarawuth, 2015).

E. Taxation in Thailand

Closely associated with legal issues are those associated with taxation. In fact the two are inseparably related and most international tax authorities believe that current tax systems and structures, founded on basic principles of neutrality, fairness, certainty and simplicity, will continue to be appropriate to cater for the changes brought by electronic transactions (Jantavongso et al., 2003).

The global nature of eBusiness raises issues of international taxation legislation and regulation that need the simultaneous cooperation of both national governments and international bodies. Taxation in particular has proved to be a very difficult area to handle within the eBusiness environment. It is difficult to apply customs duties on goods and services delivery across national boundaries. For this reason, members of the World Trade Organization (WTO) agreed since 1998 to refrain from applying customs duties on products and services delivered electronically (Chandra, 2003). However, such action by members of the WTO in refraining from applying taxation regimes to electronically delivered products and services may violate fundamental tax principles of neutrality, given that they are levied on conventional products and services. Here the point is that issues of transnational taxation are complex and must be addressed.

There are no special restrictions or regulations on eBusiness products trading over the Internet. A business that supplies goods or provides services in Thailand and has an annual turnover exceeding THB 1.2 million is subject to VAT in Thailand. Thus producers, providers of services, wholesalers, retailers, exporters and importers need to pay Value Added Tax (VAT) on goods and services. The current tariff system in Thailand is the VAT. VAT is levied at the rate of seven percent on the value of goods sold and services rendered at every level. The same rate also applies to importation. Goods imported for re-export are generally exempted from import duty and VAT. Software (freeware) such as web browsers, server software, and anti-virus software can be freely downloaded. For electronically transmitted licensed software, the Thai Revenue Department charges five percent withholding tax for software royalty payments (International Business Publications, 2013).

F. People and Education

The final critical factor in examining successful

Western eBusinesses is the level of education. In the West, the standard of education is not an issue and, as mentioned, it is an inherent feature of the West which is easily overlooked.

However, sufficient levels of education and literacy are necessary pre-conditions for an eBusiness uptake in a country. eBusinesses require their customers to have the ability to navigate the Internet. The level of education and literacy in a country determine the number of people having the necessary skills to use computers and navigate the Internet, and consequently, utilize eBusiness. Education and training are also important factors in ensuring that entrepreneurs, managers and employees, both present and future, have the necessary skills to perform successfully within an eBusiness environment. Of importance here is that the level of education and training within a country is a prime determinant of any eBusiness capability. Moreover, from an Asian and in particular a Thai standpoint, such issues must be explicitly acknowledged and addressed and cannot be taken as a given, as they might be in Western countries.

The population of Thailand is estimated at 67 million in 2015 and of these, approximately 28 million are Internet users (Charmonman, 2007). The Internet penetration rate is at 26 percent and is expected to rise (Singapore Post Limited, 2015). sCommerce is a trend for eBusiness users in Thailand, with 1.7 million, 4.5 million and 28 million users on Instagram, Twitter and Facebook respectively. Social messaging applications are a key sCommerce platform. 'Tarad.com' is a major electronic retailer in Thailand. The popular online business categories are traveling, hotels, resorts, fashion accessories, computers, and electronic appliances respectively. Thai consumers want variety when it comes to online business. Thais have access to both international and local online stores. Amazon, eBay and Agoda are popular among Thais. Thai online consumers prefer bank transfers as online payment method. Other methods are 'cash on delivery' (COD) and 'over the counter' payment. Added to this, there are approximately 8 million credit card holders in Thailand (Singapore Post Limited, 2015).

Furthermore, Thai is the national language and English is the next most commonly spoken language. The Thai population has six major ethnic groups, namely, Chinese, Malays, Cambodians, Vietnamese, Indians, and others. Of these, the Thai-Chinese ethnic group (in their second or third generation) plays a dominant role in the economic life of the country. Finally, Thailand has a very high level of literacy, the rate in 2015 of which was estimated by the UNESCO Institute for Statistics (UIS) (Huebler & Lu, 2013) as 95.2 percent (15 years and older) and 98.7 percent (15

to 24 years).

Accordingly, ICT skills courses have been offered as part of university curriculums in Thailand since 1999 (North-Chiang Mai University, 2015). To date, there are a number of undergraduate and postgraduate programs in eBusiness offered by Thai universities. For example, Master of Science Program in Electronic Business, Master of Business Administration Program in Technology and Electronic Management, Master of Information Science in Internet and Electronic Commerce Technology, Bachelor of Business Administration Program in Electronic Business, and Bachelor of Business Administration in Electronic Commerce Management.

G. Trust and eBusiness

To further understand nature of eBusinesses in Thailand, the notion of 'Trust' need to be reviewed. Whereas, there are a number of possible descriptions of trust in a normal business setting (Hawthorn, 1998; Jantavongso, 2007, 2013a; Jantavongso et al., 2003; Jantavongso et al., 2007; Sugianto & Jantavongso, 2006); there are not as many in a Thai and eBusiness context. The fundamental axiom of trust is associated with cultural affinities and inter-dependencies (Clarke, 2013). Akhter (2004) extended the definition of trust into (i) social, (ii) personal and (iii) technical perspectives. Trust can be considered as an expectation and a willingness to engage in interactions premised on a community member's recommendations or word of mouth. The personal perspective views trust as a belief or expectation that is deeply rooted in one's personality. In turn, trust from a technical perspective is related to the choice of hardware, software, authentication process and interface design that are required to build a trusted website (Akhter, 2004).

While trust is 'a confident reliance by one party on the behavior of one or more other parties' (Clarke, 2013); the trust concept has been applied outside its original social setting, including in economic context. Of relevance to this paper, it is used in the context of eBusiness. eBusiness in Thailand goes beyond commercial aspects; other clusters of trust factors include the user's circumstances, needs, and privacy.

V CONCLUSION

eBusiness provides opportunities for businesses around the world including Thailand to achieve rapid capital growth and a fast approach to build a business from scratch. However, this poses something of a dilemma in that eBusiness allows the rapid launch of new businesses at an online level whether ready or not. Fundamentally, to be successful, eBusiness must be fully prepared before launching its business on the Internet and entering a global market.

REFERENCES

- Akhter, F. (2004). *Trust in electronic commerce: social, personal, and technical perspective*. Paper presented at the Proceedings of the International Conference of the Information Resources Management Association: Innovations Through Information Technology.
- Baghdadi, Y. (2013). From e-commerce to social commerce: a framework to guide enabling cloud computing. *Journal of theoretical and applied electronic commerce research*, 8(3), 12-38.
- Blashki, K., & Jantavongso, S. (2006). *E-Business in SMEs of Thailand: A descriptive survey*. Paper presented at the Proceedings of the Emerging Trends and Challenges in Information Technology Management: Information Resources Management Association International Conference, USA.
- Board of Investment of Thailand. (2014). Logistics. Retrieved November 23, 2015, from http://www.boi.go.th/tir/issue/201410_24_10/42.htm
- Board of Investment of Thailand. (2015). Thailand in brief. Retrieved November 21, 2015, from <http://www.boi.go.th>
- Chandra, R. (2003). *Information technology in 21st century*. Delhi: Kalpaz Publications.
- Charmonman, S. (2007). *Country Report 2007 on eEverything from Thailand*. Paper presented at the Proceedings of the 24th South East Asia Regional Computer Conference, Bangkok.
- Chongruksut, W. (2002). *The adoption of activity-based costing in Thailand*. (Doctor of Philosophy), Victoria University, Footscray.
- Clarke, R. (2013). Privacy and social media: an analytical framework. *Journal of Law, Information and Science*(Online Issue).
- Croteau, D., & Hoynes, W. (2014). *Media/society: Industries, images, and audiences*. London: Sage Publications.
- Croteau, D., Hoynes, W., & Milan, S. (2012). *Media/society: Industries, images, and audiences*. London: Sage Publications.
- Deitel, H. M., Deitel, P. J., & Nieto, T. R. (2003). *Internet & world wide web how to program* Upper Saddle River: Prentice Hall.
- eMarketer. (2014). Retail sales worldwide will top \$22 trillion this year. Retrieved November 20, 2015, from <http://www.emarketer.com/Article/Retail-Sales-Worldwide-Will-Top-22-Trillion-This-Year/1011765>
- Gates, L. P. (2010). *Strategic planning with critical success factors and future scenarios: An integrated strategic planning framework*. Adelaide: Carnegie-Mellon University.
- Hawthorn, D. (1998). *Project management basics*. Zetland: Epsilon Publishing.
- Huebler, F., & Lu, W. (2013). *Adult and youth literacy: national, regional and global trends, 1985-2015*. Montreal: UNESCO Institute for Statistics.
- International Business Publications. (2013). *Doing business, investigating in Thailand guide: Volume 1 strategic and practical information*. Washington: Global Investment Centre.
- Intrapairrot, A., & Srivihok, A. (2003). The e-commerce of SMEs in Thailand. In T. Thanasankit (Ed.), *E-commerce and Cultural Values* (pp. 199-218). Singapore: Idea Group Publishing.
- Jantavongso, S. (2007). *Facilitating e-business implementation among Thai SMEs*. (Doctor of Philosophy PhD), Monash University, Clayton.
- Jantavongso, S. (2013a). *Ethics and e-health in Thailand*. Paper presented at the Proceedings of the Thai Medical Informatics Association Annual Conference and The National Conference on Medical Informatics 2013, Bangkok.
- Jantavongso, S. (2013b). Observations on SMEs' eBusiness readiness: Singaporean restaurants in Tanjong Pagar. *Rangsit Journal of Information Technology*, 1(1), 17-24.
- Jantavongso, S. (2015). Ethics, social media and e-health in Thailand. *Journal of the Thai Medical Informatics Association*, 1(1), 25-37.
- Jantavongso, S., & Li, R. (2003). *A new age e-business model for SME*. Paper presented at the Proceedings of the 9th Australian World Wide Web Conference, Australia.
- Jantavongso, S., Li, R. K., & Tootell, B. (2003). Culture and e-business in Thailand. In S. Kamel (Ed.), *Managing globally with information*

- technology. Hershey: IRM Press.
- Jantavongso, S., Sugianto, L. F., & Syau, Y.-R. (2007). *E-business deployment framework for Thai SMEs*. Paper presented at the Proceedings of the 2007 International Joint Conference of e-CASE, e-Commerce, e-Administration, e-Society, and e-Education, Hong Kong.
- Kini, R. B., & Thanarithiporn, S. (2004). Mobile commerce and electronic commerce in Thailand: a value space analysis. *International Journal of Mobile Communications*, 2(1), 22-37.
- Kiron, D., Palmer, D., Phillips, A. N., & Kruschwitz, N. (2012). Social business: What are companies really doing. *MIT Sloan management review*, 53(4), 1-32.
- Laosethakul, K., & Boulton, W. (2007). Critical success factors for e-commerce in Thailand: Cultural and infrastructural influences. *The Electronic Journal of Information Systems in Developing Countries*, 30(2), 1-22.
- Lee, I. (2013). *Trends in e-business, e-services, and e-commerce: Impact of technology on goods, services, and business transactions: impact of technology on goods, services, and business transactions*. Hershey: IGI Global.
- Leesa-nguansuk, S. (2015). Thailand Post keys on e-commerce link. Retrieved November 23, 2015, from <http://www.bangkokpost.com/lite/topstories/583099/thailand-post-keys-on-e-commerce-link>
- Lertwongsaitien, C., & Wongpinunwatana, N. (2003). E-commerce adoption in Thailand: An empirical study of Small and Medium Enterprises (SMEs). *Journal of Global Information Technology Management*, 6(3), 67-83.
- Limthongchai, P., & Speece, M. (2003). *The effect of perceived characteristics of innovation on e-commerce adoption by SMEs in Thailand*. Paper presented at the Proceedings of the Seventh International Conference on Global Business and Economic Development, Bangkok.
- Marsden, P. (2010). *Social commerce (english): Monetizing social media*. Norderstedt: Grin Verlag.
- Mitchell, W. J. (1995). *Space, place, and the infobann: City of bits*. Massachusetts: MIT Press.
- National Electronics and Computer Technology Center. (2015). NIX and ISP details. Retrieved November 15, 2015, from http://internet.nectec.or.th/internetmap/map/IX_ISP_detail.php
- North-Chiang Mai University. (2015). History of NCU. Retrieved November 24, 2015, from <http://www.northcm.ac.th/web/th/2011/aboutus.php>
- Oh, K.-H., Jantavongso, S., & Li, R. K.-Y. (2004). *A critique: factors contributing to the dotcom failures*. Paper presented at the Proceedings of the Innovations Through Information Technology: 2004 Information Resources Management Association International Conference, New Orleans.
- Panuspatthna, O. (2013). The laws and policies of Thailand in supporting electronic commerce. *Thailand Law Journal*, 1(16), 84-95.
- Patterson, G. (2011). Review of social media and defence (pp. 1-8). Commonwealth of Australia: Department of Defence.
- Philipson, G. (2002). *Australian e-business guide*. Sydney: CCH Australia Limited.
- Pimsawadi, L., & Digman, L. (2012). The impact of porters strategies utilized on the level of E-commerce adopted by large service enterprises in Thailand. *International journal*, 15(2), 117-123.
- Pornwasin, A. (2015a). Act tough on IP protection. Retrieved November 15, 2015, from <http://www.nationmultimedia.com/business/Act-tough-on-IP-protection-30265859.html>
- Pornwasin, A. (2015b). Full 4G service will transform Thailand into true digital economy: experts. Retrieved November 15, 2015, from <http://www.nationmultimedia.com/business/Full-4G-service-will-transform-Thailand-into-true-30272523.html>
- Sebora, T. C., Lee, S. M., & Sukasame, N. (2009). Critical success factors for e-commerce entrepreneurship: an empirical study of Thailand. *Small Business Economics*, 32(3), 303-316.
- Shanks, G., Arnott, D., & Rouse, A. (1993). *A review of approaches to research and scholarship in information systems*. Clayton: Department of Information Systems, Faculty of Computing and Information Technology, Monash University.
- Singapore Post Limited. (2015). 9 fundamentals for ecommerce in Thailand. Retrieved November 24, 2015, from <http://beta.singpost.com/business/knowledge-centre/factsheets/9-fundamentals-ecommerce-thailand>
- Singh, M., & Waddell, D. (2004). *E-business innovation and change management*. Hershey: IRM Press.
- Singsangob, A. (2005). *Thailand's consumer protection in electronic commerce: laws and regulations*. Paper presented at the Proceedings of the 4th International Conference on eBusiness, Bangkok.
- Suanpang, P. (2014). Tourist attitudes toward the use of e-Commerce for tourism in Thailand. *International Journal of Computers & Technology*, 12(7), 3659-3667.
- Sugianto, L. F., & Jantavongso, S. (2006). *eBusiness adoption studies focusing on Thai SMEs*. Paper presented at the Proceedings of the 2006 International Conference on Intelligent Agents, Web Technologies and Internet Commerce, Sydney.
- Sullivan, B. (2015). E-Commerce in Thailand has growth potential of \$12-15 billion. Retrieved November 23, 2015, from <http://www.thailand-business-news.com/business/50317-e-commerce-thailand-growth-potential-12-15-billion.html>
- Sutanonpaiboon, J., & Pearson, A. M. (2006). E-commerce adoption: perceptions of managers/owners of small-and medium-sized enterprises (SMEs) in Thailand. *Journal of Internet Commerce*, 5(3), 53-82.
- Tunsarawuth, S. (2015). Thailand toughens copyright law to deal with internet providers, unlawful movie recording in theaters. Retrieved November 22, 2015, from <http://www.ip-watch.org/2015/04/01/thailand-toughens-copyright-law-to-deal-with-internet-providers-unlawful-movie-recording-in-theaters/>
- U.S. Department of State. (2009). Doing Business in Thailand 2009. Retrieved November 21, 2015, from http://www.buyusainfo.net/docs/x_6572894.pdf
- Utz, S., & Muscanell, N. (2015). Social media and social capital: Introduction to the special issue. *Societies*, 5(2), 420-424.
- ZICOLaw. (2015). ASEAN Insights: Personal data protection. Retrieved November 22, 2015, from <http://www.zicolaw.com/wp-content/uploads/2013/07/ASEAN-Insights-4.pdf>

A Development of Causal Relationship Model of the Google Sites Usage for Learning at Rangsit University

Poungtong Udomsil, and Sumaman Pankham

Rangsit University, Thailand, poungtong.u@gmail.com and sumaman.p@rsu.ac.th

ABSTRACT

The study aimed to develop a causal relationship model for the usage of Google Sites for learning by using the Technology Acceptance Model (TAM) and the Social Media Acceptance Model (SMAM). The literature review indicated that there was no paper on the causal relationship model on the usage of Google Sites for learning in Thailand. The proposed model consisted of six latent variables as follows: 'Performance', 'Effort', 'Self', 'Communication Function', 'Intention', and 'Google Sites Usage'. The survey sample consisted of 450 students from Rangsit University. Structural Equation Modeling (SEM) was used to analyze the causal relationship model. Moreover, statistical analysis was conducted to create a dataset using the packed statistic program. The results indicated that the adjusted model was consistent with the empirical data. Goodness-of-Fit indicators included a Chi-square value of 545.99 with 232 degrees of freedom; CMIN/DF = 2.35; SRMR = 0.04; GFI = 0.90; AGFI = 0.90; CFI = 0.96, and RMSEA = 0.06. In summary, Google Sites Usage were positively correlated and influenced to the intention to use Google Sites for learning at Rangsit University.

Keywords: Structural Equation Modeling, Technology Acceptance Model, Social Media Acceptance Model, Technology Social Media Acceptance Model.

I INTRODUCTION

Technology Social Media Acceptance Model (TSMAM) applies 'Performance', 'Effort', 'Self', 'Communication Function', 'Intention', and 'Google Sites Usage' for learning at Rangsit University. The researcher identified the relationship of the Google Sites Usage and learning in Thailand. This study has developed the proposed models created from the Technology Acceptance Model (TAM) and the Social Media Acceptance Model (SMAM) using a research based approach.

II LITERATURE REVIEW

A. Social Media

Nowadays, social media is the most popular media. It allows users to produce, communication and share data with each other. Facebook, Twitter, YouTube and Google+ are examples of social media services. People can use social media to connect with other users throughout the world (Lenhart et al., 2010).

Google Sites can be an influential tool to support users in collaboratively building a common source of information. Google Sites is another primary tools in Google for Education. Google Sites allow users or teachers to easily create edit and preserve a frequently update multimedia websites. These sites are appropriate for use at the districts, schools, or classroom levels or for individual student projects or portfolios. Similar to Google Docs, each Google Sites can be shared with other users, allowing multiple colleagues or students to collaborate on the content. Being well-integrated with other Google services, Google Sites make it easy to embed images, video, calendar, documents, maps, slideshow, and forms. A variety of themes and templates allow a user to customize the look and feel of each site and to scaffold site set-up for students. Sites include announcement pages that can be used by educational leaders as a blog to reach as a blog to reach out to the staff, student and community. Google Sites is one popular online tool suite available to schools for free (McLeod and Lehmann, 2012).

B. Structural equation modeling

Structural Equation Modeling (SEM) is a statistical technique. SEM has extended with path analysis, which was invented by Wright (1921). In the recent years, the use of SEM has increased among educational researcher. SEM analysis starts by drawing a path diagram. It consists of boxes and circles which connected with an arrow. An observed variables are represented by rectangle or square box and latent by a circle or ellipse. An arrow with the single headed or path are used to define causal relationships in the model, an arrow with the double arrows indicate covariance or correlation without causal interpretation. The Confirmatory Factor Analysis (CFA) model in SEM represented

statistical procedure are used to estimate the number of underlying factors and the factor loading (Arbuckle, 1997; Jöreskog and Sörbom, 1989).

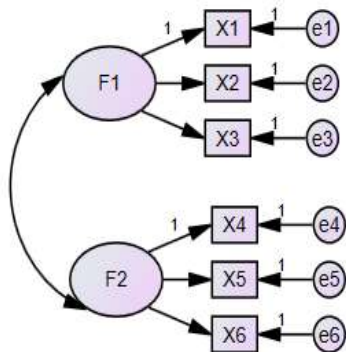

Figure 1. Confirmatory Factor Analysis (Holzinger and Swineford, 1997)

III METHODOLOGY

A. Technology Social Media Acceptance model

The purpose of this study was to develop the Technology Social Media Acceptance Model (TSMAM) which is a mixed model between the TAM and the SMAM models. Five cognitive are posited by the SMAM: ‘Performance’, ‘Effort’, ‘Self’, ‘Community Function’, and ‘Intention’. The SMAM was developed based on the e-Learning Acceptance Model (ELAM). The ELAM is an extension of the Unified Theory of Acceptance and Use of Technology (UTAUT) model, this model has used for estimate admission of e-learning in learning (Umrani-Kham and Lyer, 2009). However, using the UTAUT is not a comprehensive measurement for this study. Using the SMAM model can measure the flexibility, interactivity and self-efficacy which have not presented in the UTAUT and the TAM. Google Sites usage will show a collaboration in learning, share idea together and easy access to learning resources (Franz, 2011; Roblyer et. al., 2010). The study that use social media will cause communication in the classroom and make a collaborative skill. YouTube Usage in student’s higher-order will develop their decision skill and problem solving (Bunus, 2010; Greenhow and Roblia, 2009). Using social media in the classroom causes teachers to share videos to encourage students and their discussions with their classmate. Moreover, the SMAM model can also present self-efficacy that will refer to the student’s skill of using computing technology to indicate efficacy of social media in higher education which students who have higher self-efficacy will also show positive attitudes

toward social media that are important in determining their intentions of social media usage (Roblyer et. al., 2010; Veletsianos and Navarret, 2012). The self-efficacy is a group of social media efficacy, attitude and enjoyment (Balakrishnan and Lay, 2015).

One of well-known models is related to the Technology Acceptance Model (TAM) purposed by Davis in 1989. The TAM explains a respond or predicted of acceptance technology. Davis (1989) suggested that user can explain, motivate of use that provide a basis with trace external variable: influence, attitude, and intention to use. Four cognitive are posited by the TAM such as Perceived usefulness (Performance), Perceived ease of use (Effort), Intention and Google Site Usage (Davis et al., 1989; Adams et al., 1992). Social media sites provide various tools and applications that the services to the users as they share and exchange information. In this study, the TAM assumes that intention of use technology, which leads to actual usage and referring to Performance related activities by using Google Sites.

B. Instrument

The purpose of this study verifies the influence that Google Sites Usage for learning at Rangsit University. A questionnaire with 42 items assessing demographic details such as Google Sites Usage in a higher education. The model consisted of four types: Performance, Effort, Self and Communication Function. These categories were set as exogenous variables. Intention and Google Sites Usage was set as endogenous variables. Hypotheses were formulated on the relationships between those variable. Figure 2 shows a schematic diagram of the research model for this study.

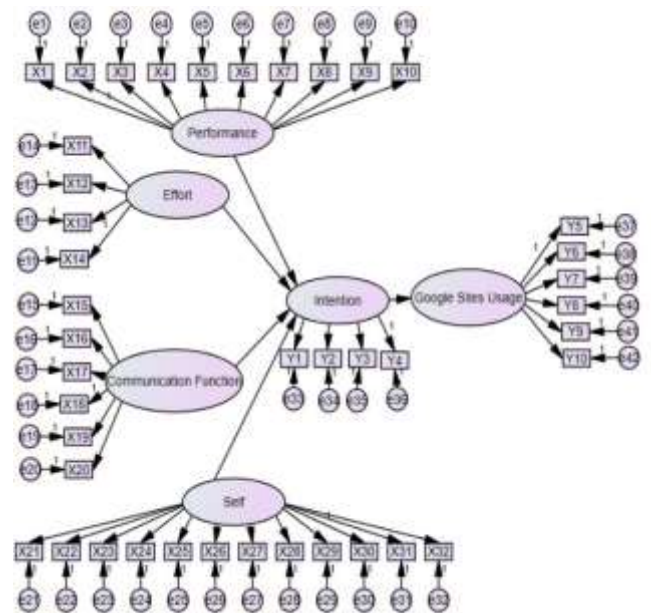

Figure 2. Technology Social Media Acceptance Model (TSMAM)

Hypotheses: To verify the variable included in the proposed research model. The study were set up hypotheses with regard to major factors that work between exogenous variables (Performance, Effort, Self and Communication Function) and an endogenous variables (Intention and Google Sites Usage) based on theoretical relevance. The questionnaire had three sections as follows.

Section A – In this segment, were questions about the overview of respondent’s gender, Year level of student, and faculty. The definition for the three different adoption Google Sites Usage were provided in the questionnaire and the respondents were asked to select the closest definition.

Section B – The item in this segment is related to the respondent’s intention to use Google Sites for grounded in learning. This consists of Performance has 10 items such as “You can develop a better understanding of the topic”. Effort has 4 items such as “Do you think that Google Sites is easy to use”. Communication Function has 6 items such as “Do you think the use of Google Sites to communicate with ease in learning more”. Self has 12 items such as “Do you agree that the use of Google Sites to help develop your knowledge”. And, Intention has 4 items such as “I think it would be interesting to use Google site for learning”.

Section C – This segment are related to the respondents’ Google Sites Usage. It has 6 items assessed the respondents’ Intention to use Google Sites for learning. Such as “You are interested in bringing Social Media into the classroom.”

C. Respondents

The self-administered questionnaires are collected from 450 student at Rangsit University in Thailand, which has used Google Sites in their classrooms in April 2016. A total of 450 questionnaires were returned and of these, 430 were completed and analyzed. Gender analysis revealed a fair distribution between male (37%) and female (62.5%).

IV RESULTS

This analysis was conducted using the Structural Equation Modeling (SEM) with a full model analysis intended to test the models and hypotheses based on the research questions. The result indicated that the adjusted model was consistent with the empirical data. Goodness-of-Fit indicators included a Chi-square value of 545.987 with 232 degrees of freedom; CMIN/DF = 2.35; SRMR = 0.04; GFI = 0.90; AGFI = 0.90; CFI = 0.95 and RMSEA = 0.06. Normally, a non-significant Chi-square result indicates a good model fit. However, the Chi-square

test is not a satisfactory test of model fit considering its dependency on sample size (Bentler and Bonett, 1980; Byrne, 1994). Therefore, several additional fit statistics were considered together with the Chi-square test. As a rule of thumb, values of relative χ^2/df less than two or three indicate a good model fit, values of RMSEA less than 0.08 indicate a reasonable fit, and values of CFI larger than 0.90 indicate an acceptable fit (Hu and Bentler, 1999). The researchers adjusted the model as the SEM suggested. The relative Chi-square to degree of freedom should be in the range 2:1 or 3:1 for an acceptable fit between the hypothetical model and sample data (Carmines and McIver, 1981). However, some researchers have recommended in the range of ratios as low as 2 (Tabachnick and Fidell, 2007) to as high as 5 (Wheaton et. al., 1977) to indicate a reasonable fit (Marsh and Hocevar, 1985).

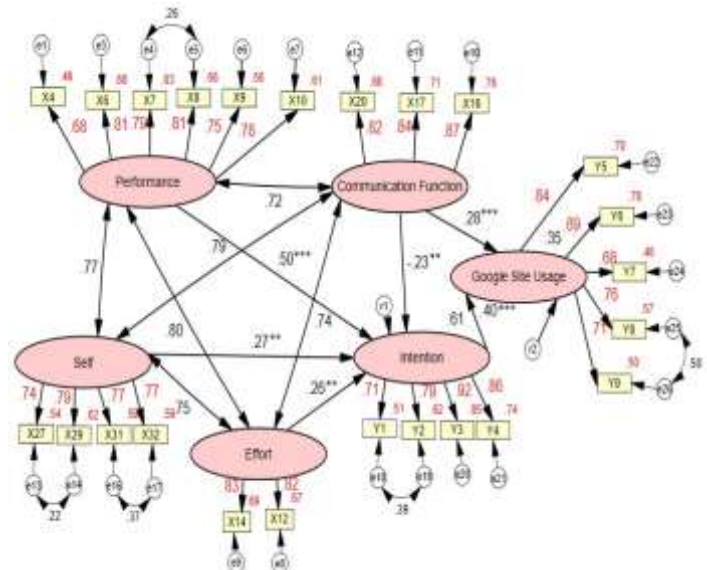

Figure 3. The Adjusted Model

Table 1. Effect of variables on the Google Sites Usage for learning.

	Intention			Google Sites Usage			Remark
	Direct effects	Indirect effects	Total effect	Direct effects	Indirect effects	Total effect	
Performance	0.50***		0.50	0.20	0.20	0.40	Support
Effort	0.26**		0.26	0.10	0.10	0.20	Support
Communication Function	-0.23**		-0.23	0.28***	-0.09	0.20	Support
Self	0.28***		0.27	0.11	0.11	0.22	Support
Intention				0.40***		0.40	Support

p ≤ 0.05, *p ≤ 0.001

The result of testing the structure model is presented in Table 1. The result shows the Communication Function has a direct effect on the Intention ($\beta = -0.23$, $p < 0.05$). The direct effect of the Communication Function on Google Sites Usage is insignificant ($\beta = 0.28$, $p < 0.001$), that the indirect

effect on Google Sites Usage through Intention ($\beta = 0.40, p < 0.001$). The result that shows Intention has a direct effect on Google Sites Usage ($\beta = 0.40, p < 0.001$).

The result shows that the Performance has direct effect on the Intention ($\beta = 0.50, p < 0.001$), that the indirect effect on Google Sites Usage through Intention ($\beta = 0.20, p < 0.05$). Effort has direct effect on Intention ($\beta = 0.26, p < 0.05$), that the indirect effect on Google Sites Usage through Intention ($\beta = 0.10, p < 0.05$). Self has direct effect on Intention ($\beta = 0.27, p < 0.05$), that the indirect effect on Google Sites Usage through Intention ($\beta = 0.11, p < 0.05$). Intention has direct effect on Google Sites Usage ($\beta = 0.40, p < 0.001$).

V CONCLUSION

The results of this study is about the causal relationship of the Google Sites Usage for learning in Thailand. It provided the innovation for higher education that interested in the educational benefits associated with Google Sites. This study revealed the numbers of benefits in learning from Google Sites. However, further research are needed. The future research will be focused on the higher educational community; and how to adopt them into the classroom. These will enhance the confidence and effectiveness for student learning. The further research will also need to be focused on the contents that engage students with a more approach in learning including the use of social media in the classroom.

REFERENCES

- Adams, D. R., Ryan, N., & Peter, T. (1992). "Perceived Usefulness, Ease of Use and Usage of Information Technology: A replication," *MIS Quarterly*, 16(2), 227-248.
- Arbuckle, J. (1997). *Amos user's guide*. Chicago, IL: Smallwaters.
- Barbara, M. B. (2010). *Structural Equation Modeling with Amos: basic concepts, applications and programing*. (2nd ed.). New York, NY: 76-77.
- Balakishnan, V., & Lay, C.G. (2015). Students' Learning Styles and Their Effects on the Use of Social Media Technology for Learning. *Telematics and Information*, 33(1), 808-821.
- Bentler, P. M. (1980). Multivariate analysis with latent variables: Causal modeling. *Annual Review of Psychology*, 31(1), 419-456.
- Byrne, B. M. (1994). *Structural equation modeling with EQS and EQS/Windows: Basic concepts, applications, and programming*. Thousand Oaks, CA: Sage.
- Bunus, P. (2010). The Social Network Classroom. Technology enhanced learning: Quality of teaching and educational reform, 73(1), 517-524.
- Carmines, E.G., & McIver, J.P. (1981). Analyzing models with unobserved variables. In Bohrnstedt, G.W. & Borgatta, E.F. [Eds.] *Social measurement: Current issues*. Beverly Hills: Sage, 80.
- Davis, F. D. (1989). "Perceived Usefulness, Perceived Ease of Use, and User Acceptance of Information Technology," *MIS Quarterly*, 13, September, 319-339.
- Duggan, M., Ellison, N. B., Lampe, C., Lenhart, A., & Madden, M. (2015). *Social Media update 2014*. Retrived November 1, 2015, from <http://www.pewinternet.org/2015/01/09/social-media-update-2014>.
- Franz, A.K. (2011). Organic chemistry YouTube writing assignment for large lecture classes. *Journal of Chemical Education*. 89(4), 497-501.
- Hu, L-T., & Bentler, P. M. (1999). Cutoff criteria for fit indexes in covariance structure analysis: Conventional criteria versus new alternatives. *Structural Equation Modeling*, 6(1), 1-55.
- Jöreskog, K.G., & Sörbom, D. (1989). *Lisrel 7: A guide to the program and application*. Chicago, ILL: SPSS.
- Marsh, H.W., & Hocevar, D. (1985). Application of confirmatory factoranalysis to the study of self-concept: First- and higher-order factor models and their invariance across groups. *Psychological Bulletin*, 97(1), 562-582.
- McLeod, S., & Lehmann, C. (2012). *What School Leader Need to Known About Digital Technologies and Social Media*. San Francisco, SF: John Wiley & sons, Inc. 142-143.
- Tabachnick, B.G., & Fidell, L.S. (2007). *Using Multivariate Statistics* (5th ed.). New York: Allyn and Bacon.
- Umrani-Khan, F., & Iyer, S. (2009). ELAM: a Model for Acceptance and use of e-learning by Teachers and Students. In: Proceedings of the International Conference on e-Learning, Institute of Technology Bombay, Mumbai, India, 475-485.
- Veletsianos, G., & Navarret, C. (2012). Online social network as formal learning environment; learner experiences and activities. *Int. Rev. Open Distance Learn.* 13(1), 144-166.
- Wheaton, B., Muthen, B., Alwin, D. F., & Summers, G. (1977). "Assessing Reliability and Stability in Panel Models," *Sociological Methodology*, 8(1), 84-136.
- Wright, S. (1921). Correlation and causation. *Journal of Agriculture Research*, 20(1), 557-585.

APPENDIX

Latent	Observe	Description
Performance	X4	Enable me to access more academic resources conveniently
	X6	Do you think Google Site enhance the skills of students.
	X7	Do you think the use of Google Site is content to better understand
	X8	Do you think the use of Google Site full fill that you need.
	X9	Do you think Google Site can make a choice based on your interests
	X10	Do you think the use of Google Site has full knowledge of the content
Effort	X12	Do you think that Google Site interaction in learning is easily understood
	X14	Do you think the use of Google Site is easy to research on learning
Communication Function	X16	You can use Google Site to discuss during class
	X17	You can collaborate with teachers more easily.
	X20	You can share technical information with others easily.
Self	X27	I use Google site for search information is easily
	X29	I feel active for use Google site
	X31	I use Google Site for review learning
	X32	I use Google site when do not understand in lesson
Intention	Y1	I think it would be interesting to use Google site for learning
	Y2	I think should have Google site to use in class
	Y3	I do not mind using Google site for learning
	Y4	I want to frequent use Google Site for learning
Google Site Usage	Y5	Review the lesson through Google site
	Y6	Do you use Google site in lessons ahead
	Y7	Send your homework or exercise instructor through Google site
	Y8	You can submit a report to the instructor via Google site
	Y9	You use Google site when have question in lesson

Exploring Competitive Competencies for ICT/Tech Startup Ecosystem Towards The Digital Economy in Thailand: An Empirical Competency Development Investigation

Kriengkrai Bhuvanij¹, M.L.Kulthon Kasemsan¹, and Prasong Praneetpolgrang²

¹Rangsit University, Thailand, {kriengkrai.b54; kkasemsan}@rsu.ac.th

²Sripatum University, Thailand, prasong.pr@spu.ac.th

ABSTRACT

Tech startups are seen as a new economic growth engine in Thailand which will help the country step up and produce more sophisticated high valued products and services. However, the shortage of skilled labor with innovation in knowledge-based economy has trapped Thailand in inconvenient position and losing its competitive edge. Hence in this research, the study on the competitive competencies for the tech startups were addressed by conducting in-depth interview and focus group discussion with the key stakeholders responsible for the development on the tech startups ecosystem in Thailand. The study revealed the top 5 competitive competencies classified by 1) Innovation, 2) Business Acumen and Aspiration, 3) Analytical Thinking, 4) Interpersonal Effectiveness and 5) Leadership and Result Orientation are needed most for the tech startup workforce and recommended strategy for the tech startup ecosystem in Thailand. The results of this research will help prepare ICT workforce in a larger scope to drive Thailand to be competitive in the Digital Economy and the ASEAN Community.

Keywords: ICT Competency, ICT/Tech Startups, ICT/Tech Startups Ecosystem, Digital Economy, Knowledge-based Service Economy.

I INTRODUCTION

Startups are the future economy foundation of Thailand gaining interest by all stakeholders due to its easiness and low cost to start business. Particularly tech startups which will help drive the next wave of growth in Thailand's digital economy, technology and innovation are the key parts to build up business while it could be designed to be replicated and expanded without limitation. The tech startups business will create high value added to economy and could grow fast. Today, the tech startups in Thailand are growing and attracting attention in the region. In addition, the tech startups business will help solve the needs of market by creating products and services which could answer and deliver value matching to the requirements of users or customers. The tech startups has business model and business operation which could be replicated with low cost including being able to

expand quickly and widely. The tech startups business could help improve quality of life by delivering faster and better service which conventional business could not do (Thailand Tech Startup Association, 2016).

Regarding the economic contribution and potential of tech startups, the Thailand Development Research Institute (TDRI) and Software Industry Promotion Agency (SIPA) reported that in 2014 alone the industry was valued at THB 7.8 billion (US\$215 million), with 20 per cent growth predicted each year forward. With this, governments in many countries, particularly in Thailand, treats tech startups as the new country strategic move and has policy to build up the tech startups ecosystem, especially the tech startups services which will replace the old services by new services owned by the country and could expand to the other countries' market. Hence in order to increase opportunity for tech startups to be successful, the governments in those countries have issued supporting measurements such as revision on laws and regulations to facilitate ease of doing business, develop local talent pool, and attract foreign talents to come and develop tech startups businesses. These will create high valued businesses, build up high-quality workforce, and increase national revenue including stimulating the economy growth. The tech startups companies in the U.S. such as Apple, Facebook, Google and Uber are good examples which could help drive economy growth of the country. With the GEDI (Global Entrepreneurship Development Institute) study in 2016, the potential of tech startups in Thailand is at the world's average which is a little higher than the ASEAN's average, however, the tech startup ecosystem in the country still is not conducive to the development of tech startups which make the tech startups in Thailand not be able to show their full potential. Hence the numbers of quality tech startups with potential investment are still limited (Thailand Tech Startup Association, 2016).

The 3 key factors impacting the development of tech startup ecosystem which the Thai government should accelerate and resolve operational improvements are the followings (Thailand Tech Startup Association, 2016):

1. Revision on laws and regulations which are not conducive to investment and support new business models.
2. Promotion on policy support to accelerate growth with quality.
3. Provision on other supports for the tech startups such as education and human resource development. With this, the Ministry of Education curriculum needs to be structured in a way that it should not focus on creating entrepreneurs but on building support personnel who are experts with entrepreneurial mindsets.

Therefore, particularly, as the education and human resources are among the key factors to help develop the tech startups workforce across the economy to be equipped with required competencies, strategy and specific measurement are needed to develop the workforce to effectively deliver and promote their ICT services, products and advice. The strategy is required to boost perceptions of ICT careers, enhance the work readiness of ICT graduates and improve industry engagement in up-skilling and professional development in an industry characterized by rapidly changing skill sets to support the tech startups to drive the Digital Economy implementation in Thailand. Hence, the ICT human resource development to build workforce in the tech startups with the right competencies to be capable enough to develop and use ICT efficiently will be a key success factor to bring the nation towards the Digital Economy and the Knowledge-based Economy:

In this research, the objectives of the study are the followings:

1. To identify the competitive competencies for the tech startups in Thailand.
2. To propose strategy for competitive competencies for tech startups ecosystem towards the Digital Economy in Thailand.

II THEORETICAL BACKGROUND

A. Tech Startup

A tech startup (or startup for short) is defined as an emerging high-growth company that is using technology and innovation to tackle a large and most often global market. The tech startups have two important defining characteristics:

1. Potential for high growth. Professional investors recognize the high risk of failure in startups and therefore will only invest in opportunities capable of generating high returns to compensate for this risk.
2. Disruptive innovation. Startups are reshaping the way entire industries work by displacing established

competitors through use of technology and business model innovation (Kinner, 2005).

In Korea a high-tech startup is defined as a firm that invests more than 5% of total sales into R&D, or if sales due to a patent account for more than 50% of total sales, or if venture capital investors control more than 10% of stockholders' equity (Sohn, 2007).

Tech startups can be pure tech firms focusing in Software and hardware as their main service or product; tech startups can also be not-so-tech who aims straight at the heart of every industry and interest including food crawls, fashion, sport etc. Angel investor Mark Birch from New York City defines them as the "non-tech" tech startups. According to him, in tech startup ecosystems, "technology is required but it is certainly not the differentiator". Technology is used behind the scenes to support, prepare and spread out the surface show of products and services (Birch, 2012).

B. Tech Startups Ecosystem

In general, Tech Startup Ecosystem is a business ecosystem formed by communities of companies, startups in various stages regarding in technology fields and an aura of other actors/organizations interacting as a system to support the creation and development of startups companies or a small-scale system that enables startups to raise (Spruijt, 2015). Each community can function independently; however, all communities in the ecosystem are linked to each other through relationships, interactions and through the same development goal of the ecosystem. As startup ecosystems are defined by the interactions of networks and communities of people, startups and organizations, they can come in either practical or virtual types which are commonly known as startup ecosystems of countries, cities or online communities. Moreover, the main actors and purpose in a tech startup ecosystem are the tech startups and the development of them, and as technology is expanding its influence to every direction (Huong, 2015).

C. Defining Knowledge Based Economy and Digital Economy

The term Knowledge Based Economy (KBE) was first coined by OECD and defined as "economies which are directly based on the production, distribution and use of knowledge and information" (OECD, 1996). Choudaha (Choudaha, 2008) used the terms such as knowledge economy, service economy, new economy, and knowledge-based service economy interchangeably. The term refers to the nature of economy that involves service interaction, complex problem-solving and technology or information based transactions. Turban (Turban et. al. 2005) defined "What is Digital Economy" is the information and entertainment products that are digitized including

processes and services which are performed in this way as well. “Digital Economy” refers to a society that is enabled and supported in every aspect of modern life by digital technologies and markets connected via the internet. Put simply, the Digital Economy is the modern economy as it is naturally evolving and therefore does not represent an optional path for Thailand, or any economy for that matter, to remain regionally and globally competitive (AEC Advisor, 2015). Other names of Digital Economy are Internet Economy, Knowledge-based Economy, Network Economy, Web-based Economy and New economy. Thus, this paper will refer the term Knowledge Based Economy to the terms “Service Economy”, “Knowledge Based Service Economy” and “Digital Economy”.

D. Competency

A competency is the capability of applying or using knowledge, skills, abilities, behaviors, and personal characteristics to successfully perform critical work tasks, specific functions, or operate in a given role or position (Ennis 2008). The iceberg model for competencies (Spencer & Spencer, 1993) takes the help of an iceberg to explain the concept of competency. Similarly, a competency has some components which are visible like knowledge and skills but other behavioral components like attitude, traits, thinking styles, self-image, organizational fit etc. are hidden or beneath the surface as shown in Figure 1.



Figure 1. Competency Ice Berg Model (Spencer and Spencer, 1993).

E. ICT Competency Model for Digital Economy

In this research, the U.S. Department of Labor (DoL) IT Competency Model (US DoL, 2014) in Figure 2 (left) which includes three layers of soft skills and workplace ready competencies: Personal Effectiveness (Layer 1), Academic (Layer 2) and Work-place (Layer 3) which have been generally validated by DoL work across other industries. In layer 4, the model represent the knowledge in ICT in 8 areas while layer 5, layer 6 and layer 7 represent industry technical, occupation specific requirements and management competencies accordingly.

As per the competencies proposed by Choudaha (Choudaha, 2008), with knowledge set in vertical part

and skills and attitudes set in horizontal part, the Competency model for a service scientist/T-shaped professional in Figure 2 (right) should well correspond to the demands on competencies of knowledge-based service sector.

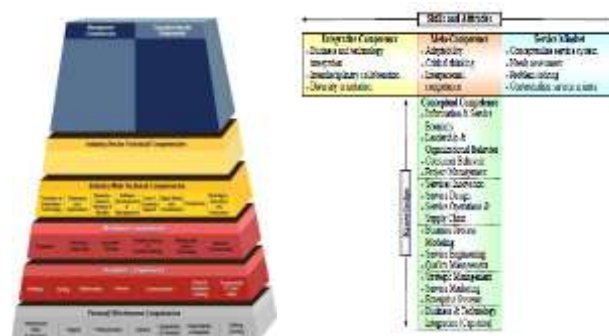

Figure 2. ICT Competency Model of U.S. Department of Labor (left) (US DoL, 2014) and Service Scientist Competency Model (right) (Choudaha, 2008)

In 2011, the Ministry of Education announced the Thailand Quality Framework (TQF) Computer standard as a foundation of education system in the country which covered in 5 majors including 1) Computer Science, 2) Computer Engineering, 3) Software Engineering, 4) IT (or ICT) and 5) Business Computing focusing in the areas of organization and ICT systems, technology for applications, technology and software process, ICT Infrastructure and Hardware and Computer Architect. The TQF Standard also defines competencies in 5 areas including Morals and Ethics, Knowledge, Cognitive Skills, Interpersonal Skills and Responsibilities and Numerical Analysis, Communications and Information Technology Skills which also aligned well with the competencies in each layer of the U.S. Department of Labor (DoL) IT Competency Model. The TQF standard also complies with the Association for Computing Machinery (ACM) and the Association for information Systems (AIS) and the Institute of Electrical and Electronics Engineer Computer Society (IEEE-CS) (TQF Computer, 2007). In this research, the US DoL IT Competency Model will be used as a foundation ICT Competency Model while the TQF Competency Model which is the core ICT knowledge along with ICT competency for Knowledge-based Service Economy and the Service Scientist Competency Model will be incorporated to construct the ICT HR Competency Development Model for Thailand towards Knowledge-based Service Economy as shown below in Figure 3.

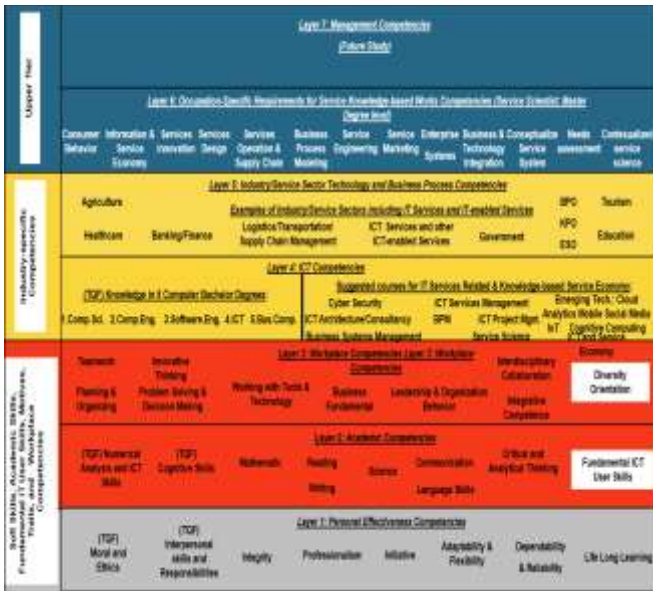

Figure 3. ICT HR Competency Development Model for Thailand towards Digital Economy/Knowledge-based Service Economy.

F. Identifying Startup Competencies

From the Documentary Research study (McCulloch, 2004) (Mogalakwe, 2006) on the 10 research papers of (Cooney, 2012) (Draycott, 2011) (Botha, 2015) (McCLELLAND, 2011) (Forster, 2013) (Morris, 2013) (Mitchelmore, 2012) (Hazlina, 2010) (Tatar, 2014) (Wu, 2009), the competencies for startups with frequency counting on each competency found in each paper is presented in Table 1.

With Documentary Research, the collective tech startup competencies were analyzed and obtained from the Table 1, the competencies with ranking with highest score on the importance could be shown in Table 2 with the highest-10-scores competency group which are Analytical Thinking, Self-Confidence and Self-Control while the lowest-6-scores competency group are Organization Awareness, Result Orientation, Verbal and Written Communication and Tolerance for Ambiguity and Risk accordingly.

With results from the ranked tech startup competencies from Table 2, all the competencies could be grouped as combination of Personal Effectiveness and Academic Competencies which could be represented in Layer 1 in the proposed tech startup competitive competency development model as shown in Figure 6 while the other parts of competency besides soft skills, academic skills, motive and traits are illustrated in Layer 2 to Layer 6 accordingly.

The proposed tech startup competitive competency development model in Figure 6 are used for the In-depth Interview with the key stakeholders in startups, government, business and academic sectors which will be later discussed in the research methodology sector.

Table 1. Collective Tech Startup Competencies.

Factor	1	2	3	4	5	6	7	8	9	10	Freq.
1. Analytical Thinking	/	/	/	/	/	/	/	/	/	/	10
2. Business Acumen	/	/	/	/	/	/	/	/	/	/	9
3. Client Service Orientation	/	/	/	/	/	/	/	/	/	/	4
4. Commitment to Learning	/	/	/	/	/	/	/	/	/	/	2
5. Communication	/	/	/	/	/	/	/	/	/	/	9
6. Conceptual Thinking	/	/	/	/	/	/	/	/	/	/	9
7. Order and Quality	/	/	/	/	/	/	/	/	/	/	4
8. Developing Others	/	/	/	/	/	/	/	/	/	/	4
9. Empathy	/	/	/	/	/	/	/	/	/	/	2
10. Expertise	/	/	/	/	/	/	/	/	/	/	9
11. Flexibility	/	/	/	/	/	/	/	/	/	/	3
12. Influence	/	/	/	/	/	/	/	/	/	/	4
13. Information Seeking	/	/	/	/	/	/	/	/	/	/	7
14. Initiative	/	/	/	/	/	/	/	/	/	/	3
15. Innovation	/	/	/	/	/	/	/	/	/	/	8
16. Organizational Awareness	/	/	/	/	/	/	/	/	/	/	6
17. Personal Motivation	/	/	/	/	/	/	/	/	/	/	7
18. Relationship Building	/	/	/	/	/	/	/	/	/	/	8
19. Results Orientation	/	/	/	/	/	/	/	/	/	/	6
20. Self-Confidence	/	/	/	/	/	/	/	/	/	/	10
21. Self-Control	/	/	/	/	/	/	/	/	/	/	10
22. Team Leadership	/	/	/	/	/	/	/	/	/	/	8
23. Verbal and Written Communication	/	/	/	/	/	/	/	/	/	/	6
24. Ambition	/	/	/	/	/	/	/	/	/	/	5
25. Ethical	/	/	/	/	/	/	/	/	/	/	2
26. Sale	/	/	/	/	/	/	/	/	/	/	7
27. Finance	/	/	/	/	/	/	/	/	/	/	7
28. Marketing	/	/	/	/	/	/	/	/	/	/	7
29. Tolerance for ambiguity and risk	/	/	/	/	/	/	/	/	/	/	6
30. Conscientiousness	/	/	/	/	/	/	/	/	/	/	4
31. Intellect	/	/	/	/	/	/	/	/	/	/	5
32. Creative	/	/	/	/	/	/	/	/	/	/	7
33. Passion	/	/	/	/	/	/	/	/	/	/	2

Table 2. Ranking of Tech Startup Competencies with Documentary Analysis.

Rank	Competencies	Score
1	Analytical Thinking	10
2	Self-Confidence	10
3	Self-Control	10
4	Business Acumen	9
5	Conceptual Thinking	9
6	Expertise	9
7	Communication	8
8	Innovation	8
9	Team Leadership	8
10	Creativity	8
11	Information Seeking	7
12	Personal Motivation	7
13	Relationship Building	7
14	Sale	7
15	Finance	7
16	Market	7
17	Organizational Awareness	6
18	Results Orientation	6
19	Verbal and Written Communication	6
20	Tolerance for ambiguity and risk	6

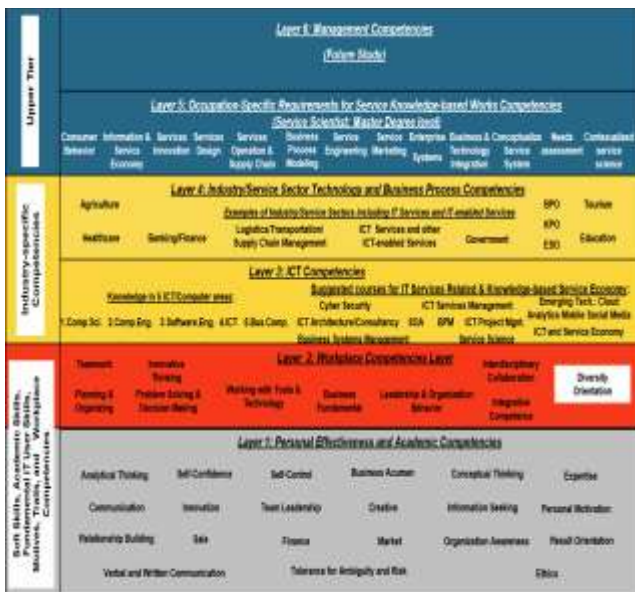

Figure 4. Proposed Tech Startup Competitive Competency Development Model.

III RESEARCH METHODOLOGY

In this research, the 3 stages of research processes consisting of: 1) Documentary Research, 2) In-depth Interview with the key stakeholders, 3) Focus group Discussion with the expert and key stakeholders in the startup ecosystem in Thailand were conducted.

As noted, from the information gained from the Documentary Research in stage 1) from table 1 and 2, and from figure 4, were used in the In-depth Interview in stage 2) with the 10 – 12 key stakeholders such as the advisor to Minister of ICT, owners of leading startup firms, executives of ICT associations, policy makers of Ministry of ICT, executives of Chamber of Commerce and SME associations and professors from academic sectors were interviewed to

verify the competencies needed for the tech startups in Thailand with the content analysis. The results from the in-depth interview were further interpreted by using the content analysis (Stemler, 2001), and then used in the Focus Group Discussion in stage 3) consisting of the 9 experts and key stakeholders responsible the development of startup sector in Thailand such as owners of the top ranked tech startups companies in Thailand, executives from Thailand Tech Startup Association, Executive Director of Software Park, executive from Thailand Professional Quality Institute, Executive Director of ICT Promotion Department of Ministry of ICT, academic professors with Knowledge Management expertise, executive of Software Industry Promotion Agency to verify the ICT Competency Development Model for ICT workforce in Thailand, specify the top 5 competitive competencies required for the tech startups in Thailand ecosystem with recommended strategy on the development of the tech startup workforce.

The two steps of research processes are as follows:

Step 1: Study and identify the competitive competencies for the tech startup in Thailand (Figure 5).

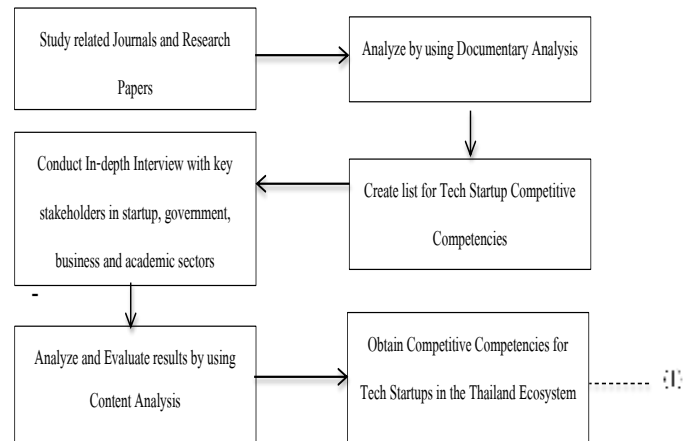

Figure 5. Step 1: In-depth Interview with Content Analysis to identify the competitive competencies for the tech startup in the Thailand Ecosystem.

Step 2: Propose strategy for competitive competencies for tech startup ecosystem towards the Digital Economy in Thailand (Figure 6).

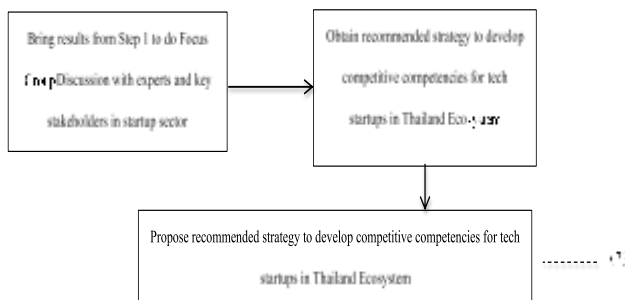

Figure 6. Focus Group Discussion to obtain proposed strategy for competitive competencies for tech startups in the Thailand ecosystem.

IV RESULTS

From the focus group discussion, the ranked tech startup competencies with Documentary Analysis from Table 2 were used to evaluate by the experts in the focus group as illustrated in Table 3 and re-order to be the top 5 recommended competitive competencies required by the tech start up in the Thailand ecosystem. The top 5 competitive competencies are, ranking from the ones which are mostly needed for the tech startups, 1) Creativity, Innovation, 2) Business Acumen, Conceptual Thinking and Personal Motivation, 3) Analytical Thinking, 4) Self Confidence, Expertise, Communication, Relationship Building, Market and Verbal and Written Communication and 5) Self-Control, Team Leadership, Result Orientation, Tolerance for Ambiguity and Risk (Table 4).

From the focus group discussion, with the results shown in Table 4, the Creativity and Innovation are mostly required for the tech startups in Thailand as the competencies could help the companies be able to create or innovate products or services, with application of technology and ICT, which could help the startups differentiate them from the competitors and from the existing products and services in the market. Regarding the second rank competitive competencies, Business Acumen including Finance and Sale, Conceptual Thinking which is the ability to see the overall picture of business while Personal Motivation are also important for the tech startups to be able to set up their company, grow, get strong, be stable and be sustainable.

Not only that, the lowest ranked competitive competencies are also important for the tech startups such as Ethics and Morality which could guide their businesses to run with integrity. Last but not least, due to the Thailand ecosystem, from the focus group discussion, the tech startups are also suggested to bring the Sufficient Economy Theory to apply for their business operation as this could help them be able to run their business with stability and sustainability.

Table 3. Competitive competencies for tech startups in Thailand Ecosystem.

No.	Competencies	% of answers by experts in the focus group discussion
1	Analytical Thinking	60%
2	Self-Confidence	40%
3	Self-Control	20%
4	Business Acumen	80%
5	Conceptual Thinking	80%
6	Expertise	40%
7	Communication	40%
8	Innovation	100%
9	Team Leadership	20%
10	Creativity	100%
11	Information Seeking	
12	Personal Motivation	80%
13	Relationship Building	40%
14	Sale	
15	Finance	
16	Market	40%
17	Organizational Awareness	
18	Results Orientation	20%
19	Verbal and Written Communication	40%
20	Tolerance for ambiguity and risk	20%
21	Ethics & Morality	20%

Table 4. Top 5 recommended competitive competencies for tech startup in the Thailand ecosystem.

Rank	Competencies	Frequency
1	Creativity, Innovation	5
2	Business Acumen, Conceptual Thinking, Personal Motivation	4
3	Analytical Thinking	3
4	Self Confidence, Expertise, Communication, Relationship Building, Market, Verbal and Written Communication	2
5	Self-Control, Team Leadership, Result Orientation, Tolerance for Ambiguity and Risk, Ethics & Morality	1

In addition, with the suggestion from the focus group session, the top 5 competitive competencies could be designed as a standard curriculum or as a short course for the existing professionals who already have been in the business to get them equipped with required competencies.

As noted, the recommended tech startup competitive competency development model in the Thailand ecosystem towards Digital Economy could also be presented as depicted in Figure 7 which the priority of education or training could be implemented by starting with the competitive competencies in Layer 1 by ranked order while at the same time the competencies on knowledge and skills in the other layers from Layer 2 – 6 could also be trained separately or in parallel to

provide the best outcomes in the tech startup human resource development.



Figure 7. Recommended Tech Startup Competitive Competency Development Model and Strategy in the Thailand Ecosystem Towards Digital Economy.

V CONCLUSION

The tech startups are the potential economic growth engine for Thailand as it helps solve the needs from market by creating products and services which could answer and match to the requirements of users or customers. The tech startups has business model and business operation which could be replicated with low cost including being able to expand quickly and widely. However, the current country's start-ups and environment do not facilitate for entrepreneurship, hence Thailand needs to step up the measurement to promote the building up of the tech start up ecosystem. Among those recommended measurement are the revision on existing laws and regulations, the promotion on policy support to accelerate growth with quality and the supports for the tech startups such as education and human resource development to build workforce with required competencies to come up with innovations.

This research explores on the competitive competencies for the tech startups addressed by conducting in-depth interview and focus group discussion with the key stakeholders responsible for the development on the tech startup ecosystem in Thailand. In the study, the top 5 ranked competitive competencies which will best suit the current tech startup workforce human resource development are discussed with the proposed competency development model and training implementation. Due to the different nature of the Thailand's tech startup ecosystem from the ones studied in the other countries, in Thailand, the key strength of the workforce in the country are service oriented culture which the innovation creativity are required and well

complement with this nature while the competencies required in the other countries, particularly, in the western ones, the analytical thinking, self-confidence and self-control are considered important. The results of this research will help prepare ICT workforce in a larger scope to drive Thailand to be competitive in the Digital Economy and the ASEAN Community.

Future research could be on the Competency Knowledge Management Model for Tech Startup in various areas such as security, supply chain management, medical tourism, agriculture and education. Furthermore studies can also be made in the Competency Knowledge Management Model for Tech Startup of Thailand in comparison to ASEAN and the Policy on Competency for Tech Startup Competency Knowledge Management Model for Tech Startup of Thailand in comparison to ASEAN, the Competency for Tech Startup Competency Knowledge Management Model for Tech Startup of other countries in ASEAN.

REFERENCES

- A Berelson, B. (1952). Content Analysis in Communication Research. Glencoe, Ill: Free Press.
- Birch, M. (2012) The Non-Tech Tech Startup. [Online] Available from: <http://birch.co/post/22367071851/the-non-tech-tech-startup>. [Accessed: 20th October 2015]
- Choudaha, R. (2008). Competency-based Curriculum For A Master's Program In Service Science, Management and Engineering (SSME): An Online Delphi Study. Morgridge College of Education, University of Denver, November 2008.
- Cooney, T. M. (2012). Entrepreneurship Skills for Growth-Orientated Businesses. Copenhagen: OECD.
- Draycott, M. (2011). Enterprise Education in Schools and the role of Competency Frameworks. Lincoln Business School, University of Lincoln.
- Ennis, R. (2008). Competency Models: A Review of the Literature and The Role of the Employment and Training Administration (ETA), U. S. Department of Labor January 29, 2008.
- ERIA. (2014). ASEAN SME Policy Index 2014: Towards Competitive And Innovative Asean SMEs, ERIA SME Research Working Group, Economic Research Institute for ASEAN and East Asia (ERIA), June, 2014.
- Forster, M., P. P. (2013). Personality: Blessing or Curse? The Entrepreneur's Path from Personal to Leadership Competencies. Organizacija, September 2013. Volume 46, pp. 221-231.
- Holsti, O.R. (1969). Content Analysis for the Social Sciences and Humanities. Reading, MA: Addison-Wesley.
- Huong Nguyen, H. (2015). Mapping Technology Startup Ecosystem In Vietnam. International Business, Business Administration, Turkey University of Applied Sciences, 2015.
- Kinner, C. (2005). Crossroads 2015: An action plan to develop a vibrant tech startup ecosystem in Australia. The StartupAUS April 2015.
- Krippendorff, K. (1980). Content Analysis: An Introduction to Its Methodology. Newbury Park, CA: Sage.
- M Botha, J. V. (2015). An integrated entrepreneurial performance model focusing on the importance and proficiency of competencies for start-up and established SMEs. S.Afr.J.Bus.Manage, pp. 55-65.
- McClelland, D. C. (2011). Small Business Entrepreneurs: Characteristics and Competencies. In D. C. McClelland, Characteristics of Successful Entrepreneurs (pp. 28-46).
- McCulloch, G. (2004). Documentary Research: In Education, History and the Social Sciences. 1st Edition. Routledge Publisher, 2004.

- Morris, M. H. (2013, June). A Competency-Based Perspective on Entrepreneurship. *Journal of Small Business Management*, pp. 352-369.
- Mitchelmore, S., Rowley, J., & Shiu, E. (2012). Entrepreneurial Competencies of Women Entrepreneurs Pursuing Business Growth. *Journal of Small Business and Enterprise Development*.
- Mogalakwe, M. (2006). The Use of Documentary Research Methods in Social Research. *African Sociological Review*. 10 (1): p. 221-230.
- Noor Hazlina Ahmad, H. A. (2010). Is Entrepreneurial Competency The Silver Bullet for SME Success in a Developing Nation. *International Business Management*, pp. 70-75.
- OECD (1996). *The Knowledge-based Economy Organization For Economic Co-Operation And Development (OECD)*, Paris, France Head of Publications Service, OECD, 1996.
- OSMEP. (2011). Office of SME Promotion (OSMEP), the 3rd National SME Promotion Plan (2012 – 2016), (www.sme.go.th).
- Sato, Y. (2013). Development of Small and Medium Enterprises in the ASEAN Economies, *BEYOND 2015: ASEAN-Japan Strategic Partnership for Democracy, Peace, and Prosperity in Southeast Asia* (pp. 154–180). Japan Center for International Exchange (JCIE), 2013.
- Sohn, Dong-Won. (2007). Universities, Clusters, and Innovation Systems: The Case of Seoul, Korea. *World Development* Vol. 35, No. 6, pp. 991–1004, 2007, 2007 Elsevier Ltd.
- Spruijt, J. (2015). Schematic overview to understand the complexity of the innovation ecosystem [infographic]. [Online] Available from: <http://www.openinnovation.eu/27-07-2015/schematic-overview-to-understand-the-complexity-of-the-innovation-ecosysteminfographic/>. [Accessed: 20th October 2015].
- Stemler, S. (2001). An Overview of content analysis, analysis. *Practical Assessment, Research & Evaluation*, 7(17). Retrieved December 2, 2014 from <http://PAREonline.net/getvn.asp?v=7&n=17>.
- Stigler, J.W., Gonzales, P., Kawanaka, T., Knoll, S. & Serrano, A. (1999). *The TIMSS Videotape Classroom Study: Methods and Findings from an Exploratory Research Project on Eighth-Grade Mathematics Instruction in Germany, Japan, and the United States*. U.S. Department of Education National Center for Educational Statistics: NCES 99-074. Washington, D.C.: Government Printing Office.
- Tatar, G. A. (2014). How are entrepreneurial competence and dynamic capabilities of the Norwegian IT Start-ups related to performance. *Repsentralen, Universitetet i Oslo*.
- Thailand Startup Association. (2016). *The Whitepaper for for Startup Thailand 2016*.
- TQF Computer. (2009). *Thailand Qualification Framework for Bachelor Degrees Computer*. Office of the Higher Education Commission, 2009.
- Turban, E., Leidner, D., & McLean, E. (2005). *Information Technology for Management: Transforming Organizations in the Digital Economy*. 5th Edition, John Wiley & Sons, Inc. 2005.
- US ABC. (2014). *Beyond AEC 2015: Policy Recommendations for ASEAN SME Competitiveness*, ASEAN SME Working Group, https://www.usasean.org/system/files/downloads/sme_report_beyond_aec2015.pdf, The US-ASEAN Business Council, August 2014.
- US DoL. (2014). *Information Technology Competency Model*. CareerOneStop, U. S Department of Labor, Employment and Training Administration, Copyright © 2014 State of Minnesota, <http://www.careeronestop.org/competencymodel/pyramid.aspx?it=Y>, 2014.
- Weber, R. P. (1990). *Basic Content Analysis*, 2nd ed. Newbury Park, CA.
- Wheelock, A., Haney, W., & Bebell, D. (2000). What can student drawings tell us about high-stakes testing in Massachusetts? *TCRecord.org*. Available: <http://www.tcrecord.org/Content.asp?ContentID=10634>.
- WU, W.-W. (2009, June). A competency-based model for the success of an entrepreneurial start-up. *WSEAS TRANSACTIONS ON BUSINESS and ECONOMICS* Issue 6, Volume 6, 279.